

# Construction Code Communicator



State of New Jersey  
Jon S. Corzine, Governor

Department of Community Affairs  
Charles A. Richman, Acting Commissioner

Volume 21, Number 2

Fall 2009

## Special Inspections

Earlier in my career when I wrote newsletter articles, I liked to write technical articles that were also comedies. I thought it would help people remember the article if there were some humor attached to it. However, this article starts not with a comedy, but with a tragedy.

Those in the Atlantic City area will probably recall an event in October 2003 that took the lives of four construction workers. The Tropicana Parking Garage Collapse that day was the subject of the largest construction lawsuit settlement in history. Because the suit was settled, the theories about the collapse were not fully sorted out, but the Department's own investigation uncovered some serious concerns about how the construction was being monitored.

Since the 1990's, the code has recognized that the spot checks afforded by the municipal building inspector are not sufficient for larger buildings with detailed masonry, concrete, welding, and bolting details. The code official simply cannot be on the site to oversee every critical concrete pour, structural weld or the torque on every bolt. The concept of special

*continued on page 2*

## Attention Electrical Subcode Officials – New FPN Bulletin on Web













Following the adoption of the National Electrical Code (NEC)/2008, the Fine Print Note (FPN) bulletin has been updated. Bulletin 09-2 was published on the Division's web site in October 2009; it will be sent to all UCC subscribers with the next update.

In the meantime, as with all UCC bulletins, Bulletin 09-2 can be viewed, printed, and downloaded from the Division's web site: [www.nj.gov/dca/codes](http://www.nj.gov/dca/codes). The specific link to bulletins can be found in the middle column under the title "View the..." The list is alphabetical and bulletins may be found under "UCC Extras."

If you have any questions on this issue, you may reach me at (609) 984-7609.

Source: Suzanne Borek  
Code Specialist

### In This Issue

2006 IECC, 2% Better than Code and REScheck 	4	Limited Use Limited Application Elevators and the Barrier Free Subcode  	8
Accessible Parking at Health Care Centers and Offices where People with Mobility Impairments Receive Health Care Services  	5	<i>New Jersey Register</i> , August 17, 2009	10
Attention Electrical Subcode Officials – New FPN Bulletin on Web 	1	Rehab and the 2008 NEC 	2
Certification to Perform Services on Unregulated Underground Heating Oil Tank Systems	6	Residential and Commercial Building Duct Insulation – There is a Difference! 	14
Children's Plumbing Fixture Requirements in Code 	12	Residential Swimming Pools and the Plumbing Subcode: UPDATE 	9
Clarification Regarding the Recent Amendment to the State Uniform Construction Code Act Concerning Technical Assistants	3	Site Remediation Reform Act -A Prior Approval Alert	7
COAH and You	8	Solar Photovoltaic Systems – How to Calculate the Fee for the Permit Application  	4
Kidde Recalls Dual Sensor Smoke Alarms; Can Fail to Warn of a Fire 	13	Special Inspections	1

continued from page 1

inspections was incorporated in to the Uniform Construction Code (UCC) to overcome this. Essentially, special inspections are inspections that are performed by a third party who is responsible for dedicating the time necessary to keep an eye on what's going on while the building is being built.

The need for special inspections was in the UCC when the Tropicana Garage was built. The good news is that there were inspections being done. The bad news is that the reports lacked sufficient detail and frequency. In addition, those completing the reports had minimal construction experience. The arrangement was the equivalent of having someone who took a CPR course oversee open heart surgery.

To ensure that special inspectors were properly qualified, the Department developed a certification program for special inspectors that became effective on November 6, 2008. The one-year anniversary of the adoption of the rule is an opportune time to remind everyone of the special inspection process and the fact that those performing special inspections must be certified.

The Special Inspection Process includes the following:

- Any Class 1 building that will use any of the construction techniques listed in Chapter 17 of the Building Subcode requires a special inspection.
- The applicant is required to give the construction official a list of special inspections that will be needed at the time of the permit application. The list is to be prepared by the design professional for the project.
- Before work begins, the applicant must supply the names and certification numbers of the people who will be performing the special inspection.
- The names and certification numbers can be verified by checking the DCA website ([www.nj.gov/dca/codes](http://www.nj.gov/dca/codes)).
- In addition, the certified special inspectors are issued wallet cards by the Department. The building subcode official can ask the special inspector to produce the wallet card.
- If the special inspector changes during the job, a permit update must be completed.
- The special inspector is required to prepare periodic reports during the progress of work and submit them to the building subcode official for review.
- At the completion of the job, the special inspector(s) is/are required to submit a final report to the construction official.

These requirements have been in place for a year, and should be enforced uniformly across the State.

If you have any questions about the implementation of the rule, please call me at (609) 984-7974.

Source: Michael Baier, Acting Chief  
Bureau of Code Services

**\* CORRECTED VERSION \***

## Rehab and the 2008 NEC

(02-03-10)

The Rehabilitation Subcode (N.J.A.C. 5:23-6) is in the process of being updated to reflect the changes from the 2005 National Electrical Code (NEC) to the 2008 NEC. Until the Rehabilitation Subcode is updated, the NEC/2005 continues to apply to work in existing buildings. However, the permit applicant may elect to use the NEC/2008 for a rehabilitation project. The following guidance is specifically related to the installation of tamper-resistant receptacles (Section 406.11) and arc-fault circuit-interrupters (Section 210.12).

N.J.A.C. 5:23-6.8(d)5 will include new Section 406.11 of the 2008 NEC. This will require replacement and newly installed receptacles to be tamper-resistant in the locations listed in Section 210.52 for dwellings. However, replacement receptacles will not require a permit because N.J.A.C. 5:23-2.7(c)3i already allows for the replacement of any receptacle, including those with ground-fault circuit-interrupter protection (Section 210.8 of the 2008 NEC).

Example: A standard receptacle is to be replaced in a bedroom. This replacement receptacle would be required to be a tamper-resistant type and would not require a permit.

N.J.A.C. 5:23-6.8(d)3 already exempts the requirements for branch circuits (Section 210.11 of the 2008 NEC). We intend to exempt arc-fault circuit-interrupter protection (Section 210.12 of the 2008 NEC) at this section of the Rehabilitation Subcode.

Example: A conductor is to be replaced with a new one that contains loads that do not exceed the original branch circuit. The existing branch circuit does not need to be replaced with one that has arc-fault circuit-interrupter protection. However, if a new branch circuit is installed and serves a bedroom, then arc-fault circuit-interrupter protection is required.

Until the Rehabilitation Subcode is updated to reflect the NEC/2008, the NEC/2005 continues to apply. This guidance should be used only if the applicant chooses to use the NEC/2008.

If you have any questions about this matter, please contact us at (609) 984-7609.

Source: Suzanne Borek and Rob Austin  
Code Specialists

## Clarification Regarding the Recent Amendment to the State Uniform Construction Code Act Concerning Technical Assistants

On August 18, 2009, Governor Jon S. Corzine signed P.L. 2009, c.119 into law. This act amends section 8 of the State Uniform Construction Code Act, N.J.S.A. 52:27D-126, so as to recognize the position and duties of a technical assistant to the construction code official and subcode official and to codify current educational requirements for that position. The amendment adds references to technical assistants in three sentences in section 8, as follows:

*The appointing authority of any municipality shall appoint a construction official [and], any necessary subcode officials and technical assistants to assist such officials to administer and enforce the code.*

*The commissioner shall, after consultation with the code advisory board, provide for educational programs designed to train and assist construction officials [and], subcode officials, and technical assistants to these officials in carrying out their responsibilities.*

*The commissioner, after consultation with the code advisory board, may periodically require that each construction official [and], subcode official, and technical assistant demonstrate a working knowledge of innovations in construction technology and materials, recent changes in and additions to the relevant portions of the State Uniform Construction Code, and current standards of professional ethics and legal responsibility; or, in the alternative, the commissioner, after consultation with the code advisory board, may accept successful completion of appropriate programs of training as proof of such working knowledge.*

While it is indeed the case that the Department has long recognized the authority of local enforcing agencies to appoint technical assistants, has authorized and recognized educational programs for technical assistants, and recognizes completion of such programs as evidence of qualification to serve as a technical assistant, the amendment has the effect of giving recognition to technical assistants by incorporating those administrative actions into the

statutory law. This is clear from the bill statement to A1351, the bill that was enacted into law as P.L. 2009, c. 119, which provides as follows:

*This bill codifies the position of technical assistant to the construction code official and subcode official, who may be appointed by a municipality to administer the Uniform Construction Code. Under the bill, a technical assistant must demonstrate an understanding of the Uniform Construction Code and the applicable regulations promulgated by the Commissioner of Community Affairs. Recently the department created a certificate program for the position of technical assistant. The bill codifies the educational requirements of the current practice, and recognizes the position and duties of the technical assistant to the construction code and subcode officials.*

The question has arisen, however, as to whether the first amendatory sentence is to be understood as requiring a municipality that does not currently have a technical assistant to hire one. While recognizing that the amendatory language to the first sentence quoted above could be written in a less ambiguous manner, it is the position of the Department that the word "necessary" applies to technical assistants, as well as to subcode officials, and that it would be incorrect to read the sentence as imposing a legislative mandate that municipalities and local enforcing agencies that do not currently employ technical assistants must hire them, whether they are needed or not.

Support for the Department's position may be found in the above bill statement, where the Legislature referred to the "technical assistant...who **may** be appointed by a municipality." When the language of a statute is ambiguous, as is the case here, it is a canon of statutory construction that the court is to look to the legislative history, of which the best evidence is the bill statement, since it says what the sponsor(s) and the committees that held hearings on the bill intended to accomplish, and thought they were accomplishing, with the legislation. Had there been any intention to impose

continued from page 3

a new requirement that municipalities hire technical assistants, the bill statement would presumably have said so.

We would also note that it would make no sense to give municipalities discretion to determine if subcode officials are "necessary," but not to make the same determination with regard to technical assistants, and that the Legislature is presumed to act logically and reasonably. Furthermore, a requirement to hire technical assistants where none are now employed would be an unconstitutional unfunded State mandate, and the Legislature should not be presumed to have acted in violation of the New Jersey Constitution when an alternative construction of the language of the legislation would avoid such a conclusion.

Source: Michael L. Tickin, Esq.  
Chief, Legislative Analysis

## Solar Photovoltaic Systems – How to Calculate the Fee for the Permit Application



The article "How Much is that Panel on the Roof?" in the Winter, 2004 *Construction Code Communicator* (Volume 16, Number 3) explained the fee for Solar Photo-Voltaic (PV) Systems. Because the electrical subcode technical section, F120, does not have a line item for PV systems, this article replaces the earlier one and provides additional clarification.

There are two commonly asked questions about how to record these systems on the electrical subcode technical section:

- (1) How are fees for PV systems charged?
- (2) Where are the work and fees recorded on the technical section?

- (1) How are fees for PV systems charged?
  - The Department has addressed this issue in its fee schedule at N.J.A.C. 5:23- 4.20(c)2iii(13), Department Fees. This section provides that, when determining charges for the PV systems, the panels themselves should not be listed; the number of arrays that the panels make must be listed. For example, when there are 32 solar panels that make two arrays totaling 10 Kw, the fee is based on the total Kw rating of the PV system.

continued on page 6

## 2006 IECC, 2% Better than Code and REScheck



Since February 20, 2007, the State of New Jersey has been using the International Energy Conservation Code (IECC)/2006, as modified per N.J.A.C. 5:23-3.18. As part of that adoption, N.J.A.C. 5:23-2.15(f)1vi(1)(A) requires that when documenting compliance using REScheck, users must exceed the IECC/2003 by two percent or more; where needed, the user should consult Bulletin 07-2 for further guidance.

It has recently come to the attention of the Department that Pacific Northwest National Laboratories (PNNL), the publishers of REScheck, has modified the program so that the Certificate of Compliance states only "Passes." It no longer prints the percentage better than code. This creates a small problem, but it is easily fixable. The percentage better than code can still be easily calculated manually using a simple formula based on the "Max Ua" and "Your Ua" (shown in the "compliance" section of the REScheck Compliance Certificate). In short, the calculation is this:

$$\left[ 1 - \frac{\text{Your Ua}}{\text{Max Ua}} \right] \times 100 = \% \text{ better than code}$$

An example from REScheck compliance certificate illustrates this calculation:

**Compliance: Passes**

Compliance: Maximum UA: **351**      Your UA: **336**

$$[1 - (336/351)] \times 100 = 4.3\% \text{ better than code}$$

If you have any questions on this matter, please contact me at (609) 984-7609

Source: Rob Austin  
Code Assistance Unit

-----

continued from page 6

The certification is not-- and will not be-- required for an aboveground heating oil tank system.

For further information about the Unregulated Heating Oil Tank program can be found at <http://www.nj.gov/dep/srp/srp/unregulatedtanks/>.

Should you have any questions on this matter, you may contact Gary Sanderson, Program Coordinator at (609) 633-0544 or me at (609) 984-7609.

Source: Thomas C. Pitcherello  
Code Assistance Unit

## **Accessible Parking at Health Care Centers and Offices where People with Mobility Impairments Receive Health Care Services**

It has come to the Department's attention that the regulations concerning accessible parking at health care centers and offices that serve people with mobility impairments have been difficult to apply for some facilities.

The requirements for accessible buildings and accessible parking for buildings constructed in New Jersey are contained in the Barrier Free Subcode (BFSC), N.J.A.C. 5:23-7. The accessible parking requirements can be found at N.J.A.C. 5:23-7.10. At N.J.A.C. 5:23-7.10(c), accessible parking requirements are established in a table that requires that approximately 1 in every 25 parking spaces be accessible. This table applies generally to publicly used buildings, except for those addressed separately at N.J.A.C. 5:23-7.10(e), medical outpatient facilities and medical facilities where specialists treat or where services are provided to people with mobility impairments; in those cases, a larger number of accessible parking spaces is required. In the case of medical outpatient facilities, 10% of the parking spaces must be accessible; in the case of medical facilities where specialists treat people with mobility impairments, 20% of the parking spaces must be accessible.

The application of these requirements is straightforward for a single use building. An example could be helpful. A building that contains only physical therapy services is clearly a building that houses specialists in the treatment of people with mobility impairments and, therefore, 20% of its parking spaces must be accessible.

Multiuse buildings, such as those where some of the space is used for offices and some of the space is used for physical therapy, are more complex. Generally speaking, accessible parking spaces serve accessible building entrances and the required accessible parking spaces are clustered near each accessible entrance. When a building has more than one accessible entrance, accessible parking spaces are distributed to ensure that each accessible entrance has accessible parking. When a portion of the building is used for the treatment of people with mobility impairments, 20% of the parking provided must be accessible. If the portion of the building that serves people with mobility impairments has its own accessible entrance, 20% of the parking spaces that serve that entrance must be accessible.

To apply the 20% accessible parking requirement to only the use that warrants it, there must be a reasonable basis for estimating the number of parking spaces that are required for that use. The number of patients that can be served in the portion of the building used for the treatment of people with mobility impairments is a reasonable basis. For example, if the physical therapy space accommodates 50 patients, then 50 parking spaces could be designated as serving that space. Of the 50 parking spaces, 20%, or 10 parking spaces, would be required to be accessible. Determining the number of parking spaces that serve a specific use should not require a variation.

Once the number of parking spaces serving the portion of the building used for the treatment of people with mobility impairments has been established, the number of required accessible parking spaces among the remaining required parking spaces is determined according to the table at N.J.A.C. 5:23-10(c). Those accessible parking spaces are then distributed among the remaining accessible entrances.

As a reminder, accessible parking spaces must be the closest parking spaces on the shortest accessible route to the accessible entrance (N.J.A.C. 5:23-7.10(a)). When accessible parking is provided, one in every eight accessible parking spaces must be van accessible (N.J.A.C. 5:23-7.10(a)2).

In sum:

- Where parking is provided, buildings with accessible entrances must have accessible parking. (N.J.A.C. 5:23-7.10(a))
- The number of required accessible parking spaces is based on the total number of spaces provided. (N.J.A.C. 5:23-7.10(c))
- There is a separate requirement for additional accessible parking spaces (10%) at medical outpatient facilities. (N.J.A.C. 5:23-7.10(e))
- Still more accessible parking spaces (20%) are required at facilities that provide services for people with mobility impairments. (N.J.A.C. 5:23-7.10(e))
- For a multi-use building, where part of the building is used to provide services for people with mobility impairments, the parking spaces allocated to that use or, should that not be available, the occupancy of the space used to

continued from page 5

continued from left

provide services for people with mobility impairments could be used to determine the number of parking spaces that are subject to the 20% accessible requirement.

- Similarly, where part of the space is used for outpatient medical facilities, the spaces allocated to that use or, should that not be available, the occupancy of the space used to provide services for people with mobility impairments could be used to determine the number of parking spaces that are subject to the 10% accessible requirement.
- The balance of the required accessible parking spaces would then be provided in numbers that comply with the Table at N.J.A.C. 5:23-7.10(c).

If you have any questions about the requirements for accessible parking spaces, please do not hesitate to contact me at (609) 984-7609.

Source: Emily W. Templeton  
Division of Codes and Standards

-----

continued from page 4

(2) Where are the work and fees recorded on the technical section?

- The work and fees are recorded on the blank line on the lower portion of the electrical technical section; the PV system is listed as one 10 Kw PV system.
- In addition, disconnects, the back-fed breaker, or panels for these system are recorded on the technical section line as "AMP Subpanels /Disconnects;" the fee is based on the ampacity rating of the device.
- Also, inverters for these systems are based on an ampacity rating and are recorded on the technical section line as "AMP Motor Control Center/Inverter." The term "inverter" after this line item indicates another form of control means for the system.
- Finally, the "Estimated Cost of Electrical Work" line should record only the electrical work costs without the framing and mounting. This amount is used to determine the fee for the DCA surcharge.

Now that we have the electrical portion figured out – let's try the building subcode technical section!! The building subcode technical section should be completed as an alteration to an existing building. The fee should be computed as a unit rate per \$1,000.00 of the estimated cost of work. This is stated in UCC at N.J.A.C. 5:23-4.18(c)1i, Standards for Municipal Fees. The only amounts that are included in the cost of work

on the building subcode technical section are the material and labor for mounting the PV system. Neither electrical material nor labor is included in cost of work on the building subcode technical section.

If you have any questions, you may reach me at (609) 984-7609.

Source: Suzanne Borek  
Code Assistance Unit

## Certification to Perform Services on Unregulated Underground Heating Oil Tank Systems

This article is to alert code officials that, on November 3, 2008, the Department of Environmental Protection (DEP) adopted rules that require a contractor who provides services on unregulated underground heating oil tank systems to pass a proficiency test in each area for which certification is being sought. Any contractor who provides services on any unregulated underground heating oil tank systems and applies for a permit from a municipality to perform this work will be required to provide proof of certification.

The Underground Storage of Hazardous Substances Act, N.J.S.A. 58:10B-21, has been amended to require all contractors performing work on unregulated tanks to be certified. In accordance with N.J.A.C. 7:14B-16.1, NJDEP has given notification in the New Jersey Register and on NJDEP's website that NJDEP has established a testing program for obtaining certification under this subchapter for individuals or business firms providing services for unregulated underground heating oil tanks.

On January 15, 2010, NJDEP will begin enforcing the provisions of N.J.A.C.7:14B-16, which will require all individuals and firms performing work on unregulated tanks to hold a certification. At the time a permit is applied for from the local municipality, a proof of certification would be required for all work performed on unregulated underground heating oil tanks as defined in N.J.A.C. 7:14B-1.6.

An individual or business firm certified in one or more classifications of regulated underground storage tank system services in accordance with N.J.A.C. 7:14B-13 is also certified for those same classifications for unregulated underground storage tank system services.

continued on page 4

# Site Remediation Reform Act

## A Prior Approval Alert

*continued from left*

Under a new law, known as the Site Remediation Reform Act, a number of the reviews and enforcement actions currently undertaken by the Department of Environmental Protection (DEP) are being transferred to private environmental consultants licensed by DEP. Many code officials have a working familiarity with DEP's regulatory programs where DEP approvals constitute prior approvals needed for the issuance of a construction permit or of a certificate of occupancy under the UCC. Most recently, code officials have had to obtain proof of the issuance of a No Further Action (NFA) letter before allowing occupancy of a new school or child care center on a site with known or suspected contamination. The Site Remediation Reform Act represents a major change in the way that the clean up of contaminated sites is handled. The approvals formerly issued directly by DEP will come from a private consultant. The following is a brief summary of the new regulatory scheme. The Department will continue to share information on these new environmental approvals as it becomes available.

The Governor signed the Site Remediation Reform Act into law on May 7, 2009. It calls for environmental consultants to be licensed and then places regulation of the clean up of contaminated sites in the hands of these licensed consultants. The newly licensed consultants will be known as Licensed Site Remediation Professionals (LSRPs.) The LSRPs will be individuals, not firms.

There will be no more approval of Remedial Action Work Plans by DEP; instead the Remedial Action Work Plan will be certified by an LSRP. And there will be no more NFA's. The NFA will be replaced by a Response Action Outcome (RAO) issued by an LSRP. There will be a whole new environmental "alphabet soup."

Implementation of this new law has already started. Some of the major provisions of the new law and steps to be undertaken by DEP include:

- The creation of a licensing board modeled on the PE licensing board. This board will be responsible for rulemaking and for licensing and regulating the LSRPs. To jump start implementation of this law, DEP is issuing temporary licenses. **As of November 4, 2009, all new cases of contaminated sites that are not already in the pipeline at DEP have to have an LSRP.** Existing, open cases may "opt in" to the new system. The temporary licenses will be good until

the time of the first exam for LSRPs offered by the licensing board. The full transition to this new system is supposed to be completed in three years.

- The law creates an affirmative obligation to perform remediation and has mandatory timeframes for the completion of remediation. DEP will be tracking remediation projects to ensure that the mandatory timeframes are met.
- A permit that stays with the property will be issued for ongoing engineering controls. These permits are to be transferred to future owners. This is to replace deed notices. Existing deed notices/deed restrictions are to be recorded in new permits. This is modeled on the system currently used by DEP for New Jersey Pollutant Discharge Elimination System (NJPDDES) permits.
- For child care centers, schools and residential uses, DEP will have the ability to disapprove a proposed remedy and to establish "presumptive remedies."
- Development on landfills will be restricted. There will be no single family dwellings constructed on landfills. The law also restricts the construction of child care centers and schools on landfills.
- A ranking system for contaminated sites will be created and DEP will have the ability to move those high on the list under its direct oversight. The DEP will also issue guidance to LSRPs on Immediate Environmental Concerns (IECs.) The LSRPs will have an obligation to notify DEP whenever an IEC is discovered.
- Technical assistance grants will be made available to community groups so that they can hire their own LSRPs.
- Unregulated Heating Oil Tanks will continue to be handled by subsurface evaluators and will not be impacted by this legislation. Those with low priority underground storage tank cases in DEP should have been informed that they are no longer under DEP's jurisdiction.
- DEP plans to create an electronic library with dated documents, including all DEP guidance and rules.

DEP is adopting interim rules through the emergency rule process. These rules will be published in the New Jersey Register on December 7, 2009 and became effective when they were filed on November 4. For those interested in more

*continued on page 8*

continued from page 7

information, including a copy of the interim rules and a list of those temporarily licensed, a link to the information on the DEP website follows: <http://www.state.nj.us/dep/srp/srra/> Any firm supplying a Response Action Outcome or other documentation should be holding a temporary license and on DEP's list.

Source: Amy Fenwick Frank  
Division of Codes and Standards

## COAH and You

As construction officials and technical assistants, you may find a municipal official across the desk from you asking questions about building permits and certificates of occupancy. Don't be alarmed. They are affordable housing planners, who either work directly for your locality or as private consultants hired to help your municipality expand housing opportunities.

The New Jersey State Supreme Court says every locality has a constitutional obligation to provide its fair share of affordable housing. The landmark cases behind this ruling involved Mount Laurel Township in Burlington County. Sometimes these affordable developments are called "Mount Laurel" housing, despite being located throughout the State. The housing can vary. It can be for the elderly, people with special needs, or family households. The housing units can be apartments for rent or condominiums for sale. All the dwellings have deed restrictions, limiting their price to those with low or moderate income. The agency created to write affordable housing rules for "Mount Laurel" development is the Council on Affordable Housing, or COAH. It determines how much affordable housing each locality must have.

This is where you come in. Building permits and certificates are one of the few sources of information available from every town, every month. Data from these records are used by a variety of people: planners, economists, demographers, market analysts who want to know what, where, and when something is built. COAH rules assign affordable housing need based on the number of dwellings and the square feet of nonresidential space from certificates of occupancy reported by your office.

Summary statistics are published each month by the Department of Community Affairs (DCA) and appear on our website at:

<http://www.state.nj.us/dca/codes/cr/conrep.shtml>

continued on page 9

## Limited Use Limited Application Elevators and the Barrier Free Subcode

Recently, the Department has received multiple questions about the requirements of the Barrier Free Subcode (N.J.A.C. 5:23-7) for the installation of Limited Use Limited Application Elevators (LULA). The following provides guidance on this issue.

**New Construction:** At N.J.A.C. 5:23-7.4, the Barrier Free Subcode allows the use of a LULA to serve as a vertical accessible route only in specified applications in large buildings (buildings of 10,000 square feet total gross enclosed floor area). They are:

- Floors or mezzanines that are less than 3000 square feet: These floors are not required to be served by a vertical accessible route. If a vertical accessible route is required (see the note that follows) or is provided, a LULA may be used.
- Floors with only mechanical equipment: These floors are not required to be served by an accessible route.
- It is important to remember that a floor that is 3,000 square feet or more is required to have an accessible route. A vertical accessible route to these floors must be provided by a commercial elevator; the use of a LULA is not permitted.

**Existing Facilities:** At N.J.A.C. 5:23-7.13, the Barrier Free Subcode lists the applications where a LULA is allowed to provide a vertical accessible route in existing buildings. They are:

- In small buildings (less than 10,000 square feet total gross enclosed floor area);
- In individual tenancies of less than 10,000 square feet in buildings of 10,000 square feet or more;
- To serve floors or mezzanines of less than 3,000 square feet; and
- In places of religious worship, Groups A-3, or E of any size.

continued on page 9



*continued from page 8*

This is what COAH looks at when it measures growth. If you go to this website, you will find tables on the dollar amount of construction and the number of dwellings, and square feet of nonresidential space for every municipality in New Jersey. The tables are updated monthly. There is a special webpage with yearly totals for every municipality.

COAH is interested in housing units and square feet of nonresidential space. They focus on certificates of occupancy. But, similar indicators appear for building permits and measure development underway. Because there usually is a lag between when a project begins and ends, if you make a mistake on the permit and catch it in time, we should be able to correct the error before you issue the certificate. But, you need to follow the process for fixing mistakes. As you work with affordable housing planners, keep in mind several things:

1. We all make mistakes. The construction data set is very big. In a good year, it measures activity from over 400,000 records, from alteration permits for small repairs, to new construction permits for large high rises. Data sets this big don't exist without mistakes. I make them. You do, too. Some are typos, an extra zero added to the area of a building, making it 1,600,000 square feet, instead of 160,000. Some are training issues. For example, someone reports the number of hotel rooms in an R-1 building as dwellings. Hotel rooms are not housing units and shouldn't be counted as such. Some are computer bugs. One recent example was flawed software that repeated indicators every time a temporary certificate of occupancy (TCO) was issued. **Don't be defensive about errors. They happen. Everyone makes them, but there is a process you need to follow to fix them.**
2. Remember the firewall. When you make a mistake, and you will, it won't be fixed simply by making a change at your end. You have to notify either Charlie Pierson, Jr. or myself at the DCA. Otherwise, the permit on our end will be wrong, even if you fixed it. The reason for this is a firewall between the DCA and construction offices. Once a permit is transmitted to us, we don't let you change it simply by editing it at your end. The firewall prevents this. It allows a permit update, because this is not an edit; it is additional information on an existing permit. Corrections are not updates and don't reach us. **Once a permit is transmitted to the DCA, a firewall prevents**

*continued on page 10*

## Residential Swimming Pools and the Plumbing Subcode: UPDATE

I wrote an article on "Residential Swimming Pools and the Plumbing Subcode" that was published in the Winter, 2008, Volume 20, Number 3 edition of the *Construction Code Communicator*. That article stated that when a residential swimming pool has two main submerged suction (bottom drains), they must be three feet apart and must also have some type of atmospheric safety vacuum release system (SVRS) provided at the pump or pumps to protect against suction entrapment.

The National Standard Plumbing Code/2006 required a SVRS, unless there were no submerged suction outlets (bottom drains) in the pool.

In the proposal for the adoption of the 2009 model codes, which includes the National Standard Plumbing Code/2009, ANSI/APSP-7 2006, "American National Standard for Suction Entrapment in Swimming Pools, Wading Pools, Spas, Hot Tubs, and Catch Basins," is referenced for suction entrapment. Please note the following change:

- ANSI/APSP-7 2006 does not require a SVRS if the swimming pool has two bottom main drains spaced at least three (3) feet apart. If only one bottom main drain is installed, including a single side wall outlet drain, then a SVRS is required.

Because adoption of the 2009 model codes is pending, the Department recommends that if a residential swimming pool has two main drains at the bottom or two submerged side wall suction outlets both spaced at least three feet apart, and that the SVRS not be required and a variation be granted.

Should you have any questions, you may contact me at (609) 984-7609.

Source: Thomas C. Pitcherello  
Code Assistance Unit

*continued from page 8*

In existing buildings, in all other applications where a commercial passenger elevator cannot be installed because it is technically infeasible, a LULA elevator may be installed provided that a variation has been approved.

If you have any questions, please call Emily Templeton at (609) 984-7609 or me at (609) 984-7833.

Source: Paulina Caploon  
Elevator Safety Unit

continued from page 9

continued from left

**municipalities from changing what was sent. To edit a record that was transmitted, building officials and technical assistants must notify the Department of such changes for the correction to appear on the website.**

3. COAH uses the construction data on the website. Website data show building permit and certificate activity for every municipality going back to 1996. There also are monthly tables. COAH uses annual certificate data to measure growth. If there is a discrepancy between what we say and what you think occurred, tell either Charlie Pierson, Jr. or me. We will work with you to track down any differences. Just because a figure appears on the website, does not mean it's right. If we report 20 new houses and you say they are sheds, something is wrong. If we catch a mistake before a permit becomes a certificate and is published in our annual tables, we will fix it. But, we don't revise historical, annual data once published. Does this mean your town is bound by a mistake in the annual tally? Of course not. The important thing is accurate data. If there is a discrepancy in what we report, we need to hear from you to understand what happened and make sure it does not happen again. You need to get an email from either Charlie or me discussing what went wrong. **These emails are suitable documentation for COAH to justify adjustments to annual figures on the website. Without such documentation, however, COAH will assume what's on the website is right.**
4. Certificates vs. permits. The website has data from both building permits and certificates, but COAH only views certificates. The first time a certificate of any kind, temporary or otherwise is issued, the status of the record changes from a permit to a certificate. Building permits are important measures of activity in progress. They are useful economic indicators. Both the DCA and the U.S. Census Bureau publish permit data monthly to measure the performance of the construction industry. Certificates of occupancy and temporary certificates of occupancy have important measure, as well. They tell a story about completed work. **Construction officials and technical assistants should review the building permit as well as certificate data on the website to make sure what we report is what you intended and both are accurate. If you make a mistake on a permit, there usually is time to correct it before the certificate is issued.**

5. Don't forget demolitions. COAH measures growth by looking at new houses and square feet of nonresidential space reported on certificates. It also considers houses and commercial space lost by demolitions. If you issued certificates of occupancy for 20 new houses one year, but tore down 30, your town did not grow. Demolitions are important. The website shows the number of dwellings lost. It also reports the number of demolition permits issued for nonresidential buildings. Unfortunately, demolition permits for commercial structures do not show the size of the buildings torn down. **The website only has the number of nonresidential demolitions, not the sizes of these buildings. If you have this information, it will be helpful to affordable housing planners. Otherwise, you have to direct them to some other source, like local tax rolls.**
6. Read the tea leaves. Construction data paint a picture of development patterns with broad brush strokes. These data need to be skillfully interpreted. The construction official, technical assistant, and planner must work together to interpret building permit and certificate data. You know what and how much is being built in your community. Your help is needed to make sense of the numbers and accurately measure growth. Let the planner know if a new development in your community has income limits. New deed-restricted housing does not generate more growth under the COAH rules. **Work with planners to improve the quality of the reported data and help them understand the settlement patterns in your community.**

If you have questions, call me, at 609-292-7898 or email me at [jlago@dca.state.nj.us](mailto:jlago@dca.state.nj.us).

Source: John Lago  
Division of Codes and Standards

## ***New Jersey Register*** **Adoptions**

**August 17, 2009:**

**N.J.A.C. 5:23-3.14 and 12.2 -- Building Subcode and Elevator Subcode**

The American Society of Mechanical Engineers (ASME) A17.1/2004-2005, which was adopted by

continued at right

continued on page 11

*continued from page 10**continued from left*

reference with the 2006 International Building Code (IBC/2006), contains expanded maintenance requirements (retrofit provisions and some maintenance planning provisions) that were not included in prior ASME A17.1 standards. These amendments return maintenance requirements for elevators and escalators to those of ASME A17.1/1996-1998, the requirements in effect prior to adoption of the ASME A17.1/2004-2005 standard.

**N.J.A.C. 5:23-7.2 and 7.5 -- Barrier Free Subcode**

At N.J.A.C. 5:23-7.2, Accessibility standard, an amendment is adopted in the technical standard for accessible design, the International Code Council/American National Standards Institute (ICC/ANSI) A117.1-2003, to make it clear that accessible reach ranges and clear floor space are required for an electrical panelboard that is installed in a newly constructed accessible dwelling unit, but that the other requirements of this section of ICC/ANSI A117.1, which provide that the operating mechanisms allow no twisting, pinching, or turning the wrist, do not apply to electrical panelboards.

The correction of the cross reference in N.J.A.C. 5:23-7.5, Residential buildings other than buildings of Group R-1, ensures that the cross reference for assisted living facilities leads the code user to N.J.A.C. 5:23-7.11, Requirements applicable to nonresidential Groups and Group R-1, to find the requirements for assisted living facilities and the requirements for accessible parking at N.J.A.C. 5:23-7.10.

**September 8, 2009:**

**N.J.A.C. 5:23-2.23(I) -- Certificate of Compliance for Backflow Preventers:**

The amendment requires backflow preventers that are designed to be tested and used to isolate sources of contamination, as defined in the plumbing subcode, to be tested at least once every 12 months in order to receive a certificate of compliance. The only exception is testable backflow preventers that are installed on water supplies in one- or two-family dwellings that are not connected to a high hazard irrigation system. This change would be consistent with section 10.5.6 of the plumbing subcode.

**Amendments to the Uniform Construction Code Act (N.J.S.A. 52:27D-119 et seq.)**

**N.J.S.A. 52:27D-122.2 and 123** – The Act was amended, by P.L. 2009, c. 106, to authorize the Department to adopt energy conservation requirements that go beyond those contained in the national model

code provided that the added cost of each enhanced energy conservation construction requirement may be recovered over a period of not more than seven years.

**N.J.S.A. 52:27D-126** – The Act was amended, by P.L. 2009, c. 119, to recognize the position and duties of a technical assistant to the construction code official and subcode official, who may be appointed by a municipality to administer the Uniform Construction Code; this amendment also codifies current educational requirements.

**May 18, 2009:**

**N.J.A.C. 5:23-2.15 -- Construction Permit Applications, Plan Review**

This amendment allows plan review to proceed, even though required State, county or local prior approvals may not have been granted, provided that the application for a permit is otherwise complete and the plan review fee has been paid. However, the permit may not be issued until all required State, county and local approvals are in place. An exception to this plan review provision is made for individual owner-occupied one- or two family home addition or rehabilitation projects, which are required to have zoning approval in place before plan review may proceed.

**N.J.A.C. 5:23-2.23 -- Certificate Requirements, Temporary Certificate of Occupancy**

This amendment to N.J.A.C. 5:23-2.23(g) deletes the requirement that a temporary certificate of occupancy (TCO) be issued for a period of not fewer than 60 days. While the issuance of a TCO for a period of at least 60 days generally makes good administrative sense, both in order to allow sufficient time for work not affecting health and safety to be completed and to avoid the need for excessive paperwork, there have been instances in which the inflexibility that this provision established hampered the ability of code officials to get issues resolved expeditiously.

**July 7, 2009:**

**N.J.A.C. 5:23-3.11A -- Public School Facility Plan Review and Inspections; Uniform Construction Code Enhancements in Public School Facilities**

The Department of Community Affairs discovered an error at N.J.A.C. 5:23-3.11A(c)2. The following phrase in the paragraph's first sentence, "and other exterior exits that are required to serve 50 or more persons," appeared in the UCC omitting the word "exterior." A notice of administrative correction was published restoring the word "exterior."

Source: Rob Austin  
Code Assistance Unit

*continued at right*

continued from left

# Children's Plumbing Fixture Requirements in Code



The Department has been receiving multiple questions about the use of child-sized toilet fixtures. In both the National Standard Plumbing Code/2006 (NSPC/2006) and the ICC/ANSI A117.1-2003 (ICC/ANSI-2003) standard, the provisions for the installation of adult-sized plumbing fixtures satisfy the requirements for fixtures to be used by children. The design professional may adjust the dimensions of the fixtures for children's use; to this end, both the NSPC/2006 and the ICC/ANSI A117.1-2003 contain standards for child-sized fixtures. NOTE: At N.J.A.C. 6A:26-6.3(h)4i2, schools that are under the jurisdiction of the New Jersey Department of Education (DOE) are required to use child-sized fixtures.

### Modifications to General Plumbing Fixtures for Children, NSPC/2006 (and NSPC/2009)

Section 7.4.3, Contour of Bowls, states that the water closet shall have an elongated bowl and an open-front seat.

Child-sized Fixture: Exception 4 provides an exception for water closets installed in pre-schools and kindergartens; these installations are not required to have open-front seats.

Section 7.4.4, Bowl Height, states that the height of water closet bowls shall be a minimum of 13 1/2 inches from the floor to the top of the rim.

Child-sized fixture: Exception 1 provides that bowls intended for children's use (5 years and younger) are allowed to be 9 1/2 inches - 10 1/2 inches high measured to the top of the rim; and those intended for juvenile use (6-12 years) are allowed to be 10 1/2 inches - 13 1/2 inches high measured to the top of the rim.

### Modifications to Accessible Plumbing Fixtures for Children, ICC/ANSI-2003

Section 106.5 defines "children's use" as spaces and elements specifically designed for use primarily by people 12 years old and younger.

Section 602.2, Clear Floor Space (for Drinking Fountains)

Child-sized drinking fountain: Exception 2 states that drinking fountains intended primarily for children's use may be provided. The spout must be 30 inches maximum above the floor, and a parallel approach complying with Section 305, must be provided and must be centered on the drinking fountain.

continued at right

Section 604.1, General (Water Closets and Toilet Compartment)

Child-sized water closet and toilet compartment: An exception is provided that allows water closets and toilet compartments primarily for children's use to comply with Section 604.10 as applicable. (See below.)

Section 604.8.2, Size (of Wheelchair Accessible Toilet Compartments)

Child-sized wheelchair accessible toilet compartment: A child-sized wheelchair accessible toilet compartment that is intended primarily for children's use shall be 60 inches minimum in width measured perpendicular to the side wall, and 59 inches minimum in depth for both wall hung and floor mounted water closets measured perpendicular to the rear wall.

Section 604.8.5, Toe Clearance (for Wheelchair Accessible Compartments)

Child-sized Toe Clearance in Wheelchair Accessible Toilet Compartments: Exception 1 permits that, in a compartment primarily for children's use that is greater than 65 inches in depth, toe clearance at the front partition is not required.

Section 604.10, Water Closets and Toilet Compartments for Children's Use

Child-sized Water Closets and Toilet Compartments: Subsection 604.10.2, Location, states that the water closet shall be located with a wall or partition to the rear and to one side. Also, the centerline of the water closet shall be 12 inches minimum to 18 inches maximum from the side wall or partition. Lastly, water closets located in ambulatory accessible toilet compartments specified in Section 604.9 shall be located as specified in Section 604.2.

Fig. 604.10.2  
Children's Water Closet Location

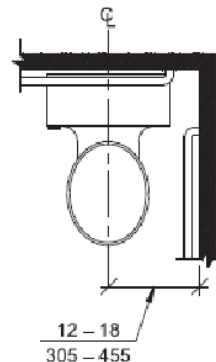

continued on page 13

continued from page 12

continued from left

Subsection 604.10.3, Clearance, states that a clearance around a water closet complying with Section 604.3 shall be provided.

Subsection 604.10.4, Height, states that the height of water closet seats shall be 11 inches minimum and 17 inches maximum above the floor, measured to the top of the seat. Also, seats shall not be sprung to return to a lifted position.

**Fig. 604.10.4**  
**Children's Water Closet Height**

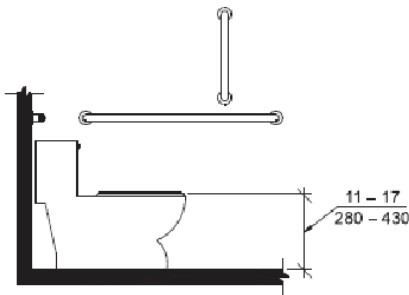

Subsection 604.10.5, Grab Bars, states that grab bars for water closets shall comply with Section 604.5.

Subsection 604.10.6, Flush Controls, states that flush controls shall be hand operated or automatic. It also states hand operated flush controls shall comply with Sections 309.2 and 309.4 and shall be installed 36 inches maximum above the floor. Flush controls shall be located on the open side of the water closet. However, the exception states that ambulatory accessible compartments complying with Section 604.9 may have flush controls located on either side of the water closet.

Subsection 604.10.7, Dispensers, states that toilet paper dispensers shall comply with Section 309.4 and shall be 7 inches minimum and 9 inches maximum in front of the water closet measured to the center line of the dispenser. It also states that the outlet of the dispenser shall be 14 inches minimum and 19 inches maximum above the floor. Furthermore, there shall be a clearance of 1½ inches minimum below the grab bar. Lastly, dispensers shall not be of a type that control delivery or do not allow continuous paper flow.

continued at right

**Fig. 604.10.7**  
**Children's Dispenser Location**

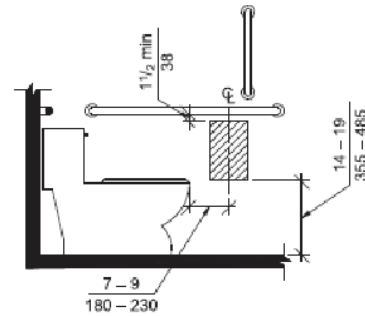

Subsection 604.10.8, Toilet Compartments, states that toilet compartments shall comply with Sections 604.8 and 604.9, as applicable.

Section 606.2, Clear Floor Space (for Lavatories and Sinks), states as per exception 3, a knee clearance of 24 inches minimum above the floor shall

continued on page 15

## Kidde Recalls Dual Sensor Smoke Alarms; Can Fail to Warn of a Fire

WASHINGTON, D.C. - The U.S. Consumer Product Safety Commission, in cooperation with the firm named below, has announced a voluntary recall of the following consumer product. Consumers should stop using recalled products immediately unless otherwise instructed.

**Name of Product:** Kidde Model PI2000 Dual Sensor Smoke Alarms

**Units:** About 94,000

**Manufacturer:** Walter Kidde Portable Equipment Inc., of Mebane, N.C.

**Hazard:** An electrostatic discharge can damage the unit, causing it not to warn consumers of a fire.

**Incidents/Injuries:** The firm has received two reported incidents of smoke alarm malfunctions involving electrostatic discharge during installation. No injuries have been reported.

continued on page 15

## Residential and Commercial Building Duct Insulation – There is a Difference!



### Low-rise residential buildings

Section 403.2.1, Insulation, of the International Energy Conservation Code/2006, requires supply and return ducts that are not within the thermal envelope to be insulated to a minimum of R-8 with the exception of ducts in floor trusses, which must be insulated to a minimum of R-6. This applies to all new one- and two-family detached dwellings and multiple family dwellings that are three stories or less in height.

### All other buildings

Section 6.4.4.1.2, Duct and Plenum Insulation, of the ASHRAE Standard 90.1-2004 requires all supply and return ducts and plenums installed as part of an HVAC air distribution system, and that are not within the thermal envelope, to be thermally insulated in accordance with Tables 6.8.2A and 6.8.2B (condensed tables are provided below). These requirements vary by climate zone. At N.J.A.C. 5:23-3.18(b)5i, climate zones for “all other buildings” are Zone 4, except for Bergen, Hunterdon, Morris, Passaic, Somerset, Sussex and Warren Counties, which are Zone 5.

**TABLE 6.8.2A Minimum Duct Insulation R-Value<sup>a</sup>, Cooling and Heating Only Supply Ducts and Return Ducts**

Climate Zone	Duct Location						
	Exterior	Ventilated Attic	Unvented Attic Above Insulated Ceiling	Unvented Attic with Roof Insulation <sup>a</sup>	Unconditioned Space <sup>b</sup>	Indirectly Conditioned Space <sup>c</sup>	Buried
<b>Heating Ducts Only</b>							
4	R-3.5	none	none	none	none	none	none
5	R-6	R-3.5	none	none	none	none	R-3.5
<b>Cooling Only Ducts</b>							
4	R-3.5	R-3.5	R-6	R-1.9	R-1.9	none	none
5, 6	R-3.5	R-1.9	R-3.5	R-1.9	R-1.9	none	none
<b>Return Ducts</b>							
1 to 8	R-3.5	R-3.5	R-3.5	none	none	none	none

- a Insulation R-values, measured in (h·ft<sup>2</sup>·°F)/Btu, are for the insulation as installed and do not include film resistance. The required minimum thicknesses do not consider water vapor transmission and possible surface condensation. Where exterior walls are used as plenum walls, wall insulation shall be as required by the most restrictive condition of 6.4.4.2 or Section 5. Insulation resistance measured on a horizontal plane in accordance with ASTM C518 at a mean temperature of 75°F at the installed thickness.
- b Includes crawl spaces, both ventilated and nonventilated.
- c Includes return air plenums with or without exposed roofs above.

**TABLE 6.8.2B Minimum Duct Insulation R-Value<sup>a</sup>, Combined Heating and Cooling Supply Ducts and Return Ducts**

Climate Zone	Duct Location						
	Exterior	Ventilated Attic	Unvented Attic Above Insulated Ceiling	Unvented Attic w/ Roof Insulation <sup>a</sup>	Unconditioned Space <sup>b</sup>	Indirectly Conditioned Space <sup>c</sup>	Buried
<b>Supply Ducts</b>							
4	R-6	R-6	R-6	R-3.5	R-3.5	none	R-3.5
5	R-6	R-6	R-6	R-1.9	R-3.5	none	R-3.5
<b>Return Ducts</b>							
1 to 8	R-3.5	R-3.5	R-3.5	none	none	none	none

- a Insulation R-values, measured in (h·ft<sup>2</sup>·°F)/Btu, are for the insulation as installed and do not include film resistance. The required minimum thicknesses do not consider water vapor transmission and possible surface condensation. Where exterior walls are used as plenum walls, wall insulation shall be as required by the most restrictive condition of 6.4.4.2 or Section 5. Insulation resistance measured on a horizontal plane in accordance with ASTM C518 at a mean temperature of 75°F at the installed thickness.
- b Includes crawl spaces, both ventilated and non-ventilated.
- c Includes return air plenums with or without exposed roofs above.

Source: Rob Austin  
Code Assistance Unit

continued from page 13

**Description:** This recall involves Kidde dual sensor smoke alarms model PI2000. The alarms can be identified by two buttons, "HUSH" and "PUSH AND HOLD TO TEST WEEKLY," which are located on the front/center of the alarm. The model number and date code are on the back of the smoke alarm. Only date codes 2008 Aug.01 through 2009 May 04 are included in this recall.

**Sold at:** Retail, department, and hardware stores and through electrical distributors nationwide from August 2008 through May 2009 for between \$30 and \$40.

**Manufactured in:** China

**Remedy:** Consumers should contact Kidde immediately to receive a free replacement smoke alarm.

**Consumer Contact:** For additional information, contact Kidde toll-free at (877) 524-2086 between 8 a.m. and 5 p.m. ET Monday through Friday, or visit the firm's Web site at [www.kidde.com](http://www.kidde.com)

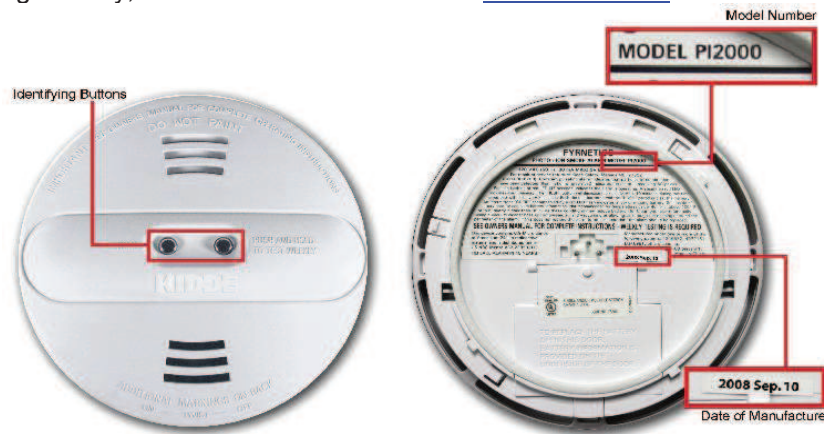

Please make sure your fire officials are aware of this voluntary recall so the units can be identified upon inspections for resale or re-occupancy. When performing routine inspections, dwelling unit alarms should also be checked in all R and I Group occupancies. If any of these alarms were installed, the consumers need to contact Kidde for a free replacement.

Source: Michael E. Whalen  
Code Assistance Unit

continued from page 13

continued from left

be permitted at lavatories and sinks used primarily by children ages 6 through 12 where the rim or counter surface is 31 inches maximum above the floor. And, as per exception 4, a parallel approach complying with Section 305 shall be permitted at lavatories and sinks used primarily by children ages 5 and younger.

If you have any questions, I may be reached at (609) 984-7609.

Source: Rob Austin  
Code Assistance Unit

Section 609.4, Position of Grab Bars, states that water closets primarily for children's use complying with Section 604.10, grab bars shall be installed in a horizontal position 18 inches minimum to 27 inches maximum above the floor measured to the top of the gripping surface.

continued at right

New Jersey Department of Community Affairs  
Division of Codes and Standards  
101 South Broad Street  
P.O. Box 802  
Trenton, NJ 08625-0802

BULK RATE  
US POSTAGE  
PAID  
PERMIT NO.  
XXXXX

**FIRST-CLASS MAIL**

Mail to: 