NEW JERSEY OPERATORS INSTRUCTIONAL MANUAL

Manual Version 1.0

(Software V1.2)

March 03, 2010

Prepared by SGS Testcom, Inc.

NEW JERSEY OPERATORS INSTRUCTION MANUAL

INTRODUCTION

Table of Contents

Chapter 1: Introduction	1-1
OPTIONAL EQUIPMENT	1-2
NJ2009 WORKSTATION.....	1-2
LENOVO PC WITH LCD MONITOR, KEYBOARD, AND OPTICAL MOUSE	1-3
LASER PRINTER	1-4
BAR CODE SCANNER	1-4
OBDII INTERFACE MODULE	1-5
GAS CAP TESTER	1-6
BIOMETRIC FINGERPRINT READER	1-6
GENERAL HELP/PHONE NUMBERS.....	1-8
NJ2009 WORKSTATION HELP	1-8
ABOUT THIS OPERATORS MANUAL.....	1-8
SAFETY INFORMATION	1-8
WARNING SYMBOLS	1-8
SAFETY INSTRUCTIONS.....	1-9
RISK OF ELECTRIC SHOCK.....	1-9
RISK OF PERSONAL INJURY	1-10
SYSTEM REQUIREMENTS.....	1-10
Chapter 2: Main Menu	2-2
Chapter 3: NJ2009 Workstation Operation	3-1
TURNING THE WORKSTATION ON	3-1
WORKSTATION OPERATION CAUTIONS.....	3-1
SHUTTING DOWN THE WORKSTATION.....	3-2
LOADING NEW SOFTWARE	3-2
Chapter 4: Vehicle Inspection Menu (1).....	4-1

NEW JERSEY OPERATORS INSTRUCTION MANUAL

INTRODUCTION

VEHICLE INSPECTION MENU	4-1
(1) PERFORM INSPECTION	4-2
(2) REPRINT VIR.....	4-1
(4) DLC LOCATION REFERENCE	4-1
Chapter 5: The Diagnostic Menu (2)	5-1
DIAGNOSTIC TEST MENU (2)	5-2
(1) OBDII SCAN.....	5-2
(2) OPACITY DIAGNOSTIC TEST	5-1
Chapter 6: Equipment Checks/CALIBRATIONS Menu	6-2
EQUIPMENT CHECKS AND CALIBRATIONS MENU.....	6-2
(2) PRINTER AND BARCODE	6-4
Chapter 7: The Utilities Menu.....	7-10
UTILITIES MENU	7-10
(1) DATA FILE REFRESH FROM THE UTILITIES MENU.....	7-11
DATA FILE REFRESH MESSAGE.....	7-12
(2) WORKSTATION STATUS SCREEN FROM THE UTILITIES MENU.....	7-13
(3) PRINTER SETUP SCREEN FROM THE UTILITIES MENU.....	7-14
(4) REQUEST REMOTE HELP SCREEN FROM THE UTILITIES MENU	7-15
(5) INTERNET CONNECTION CHECK SCREEN FROM THE FROM THE UTILITIES MENU	7-16
(6) DIAL TONE CHECK SCREEN FROM THE FROM THE UTILITIES MENU	7-17
Chapter 8: View Messages.....	8-20
Chapter 9: The Workstation Management Menu	9-24
(1) DATA FILE REFRESH SCREEN	9-27
(2) CHANGE WORKSTATION PASSWORD	9-28
(3) EQUIPMENT MAINTENANCE.....	9-29
(4) UPDATE SOFTWARE FROM CD.....	9-30

NEW JERSEY OPERATORS INSTRUCTION MANUAL

INTRODUCTION

(5) INTERNET ACCESS SETUP.....	9-31
(6) INTERNET CONNECTION CHECK.....	9-32
(7) INITIALIZATION.....	9-33
(8) REPORTS MENU	9-36
(9) VIEW FACILITY INFORMATION.....	9-37
Chapter 10: Repair Data Entry.....	10-40
Chapter 11: Troubleshooting.....	11-44
VIEWSONIC 17" LCD MONITOR TROUBLESHOOTING PROCEDURES:.....	11-44
NO POWER.....	11-44
POWER IS ON BUT NO SCREEN IMAGE	11-44
WRONG OR ABNORMAL COLORS.....	11-44
CONTROL BUTTONS DO NOT WORK	11-44
HONEYWELL HHP 4600 BARCODE SCANNER TROUBLESHOOTING PROCEDURES:	11-46
RESET THE BAR CODE SCANNER SETTINGS	11-47
WAEKON FPT27 GAS CAP TESTER TROUBLESHOOTING PROCEDURES:.....	11-48
PRINTER JAMS	11-50
BASIC PRINTER TROUBLESHOOTING PROCEDURES	11-64
OBDII INTERFACE MODULE TROUBLESHOOTING PROCEDURES:	11-81
Chapter 12: Equipment Maintenance.....	12-84
Chapter 13: Mobile Workstation	13-86
HANDHELD USE IN THE MOBILE WORKSTATION	13-86
BARCODE SCANNING - HANDHELD	13-88
GAS ANALYZER EMISSIONS TESTS - HANDHELD.....	13-89
MIL TEST - HANDHELD	13-91
OBD TEST - HANDHELD.....	13-93

NEW JERSEY OPERATORS INSTRUCTION MANUAL

INTRODUCTION

Table of Figures

FIGURE 1-1: NJ WORKSTATION.....	1-2
FIGURE 1-2: LENOVO PC WITH LCD MONITOR, KEYBOARD, AND OPTICAL MOUSE.....	1-3
FIGURE 1-3: LEXMARK LASER PRINTER.....	1-4
FIGURE 1-4: BAR CODE SCANNER.....	1-5
FIGURE 1-5: OBDII INTERFACE MODULE.....	1-5
FIGURE 1-6: GAS CAP TESTER.....	1-6
FIGURE 1-7: BIOMETRIC FINGERPRINT READER.....	1-7
FIGURE 2-1: MAIN MENU.....	2-2
FIGURE 4-1: MAIN MENU.....	4-1
FIGURE 4-2: VEHICLE INSPECTION MENU.....	4-2
FIGURE 4-3: VEHICLE INSPECTION MENU LOG IN SCREEN MANUAL ENTRY.....	4-3
FIGURE 4-4: SCAN VEHICLE VIN SCREEN.....	4-4
FIGURE 4-5: VEHICLE VIN MANUAL ENTRY.....	4-5
FIGURE 4-6: SCAN VEHICLE REGISTRATION.....	4-6
FIGURE 4-7: DOCUMENT VIN MANUAL ENTRY.....	4-7
FIGURE 4-8: LICENSE PLATE MANUAL ENTRY.....	4-8
FIGURE 4-9: FAILED VIR CHECK SCREEN.....	4-9
FIGURE 4-10: ENTER OLD STICKER DATE SCREEN.....	4-10
FIGURE 4-11: DOCUMENT VIN MANUAL ENTRY.....	4-11
FIGURE 4-12: SELECTED TESTS SCREEN.....	4-12

NEW JERSEY OPERATORS INSTRUCTION MANUAL

INTRODUCTION

FIGURE 4-13: SUMMARY CREDENTIAL TEST SCREEN	4-13
FIGURE 4-14: (1) DRIVER'S LICENSE SUMMARY CREDENTIALS.....	4-14
FIGURE 4-15: PRE-TEST INSPECTION SCREEN	4-15
FIGURE 4-16: SUMMARY SAFETY TEST SCREEN	4-16
FIGURE 4-17: SAFETY EQUIPMENT STANDARD IM SAFETY TEST SCREEN	4-17
FIGURE 4-18: STANDARD IM SAFETY TEST - LIGHTS OPTIONS	4-18
FIGURE 4-19: BEGIN CATALYTIC CONVERTER VISUAL INSPECTION.....	4-19
FIGURE 4-20: PERFORM CATALYTIC CONVERTER VISUAL INSPECTION	4-20
FIGURE 4-21: PERFORM TEST "LIQUID LEAK CHECK" SCREEN.....	4-21
FIGURE 4-22: PERFORM TEST "VISIBLE SMOKE TEST" SCREEN	4-22
FIGURE 4-23: KEY ON ENGINE OFF (KOE0).....	4-23
FIGURE 4-24: TURN KEY OFF (MIL CHECK)	4-24
FIGURE 4-25: KEY OFF TIMER (MIL CHECK)	4-25
FIGURE 4-26: KEY ON ENGINE RUNNING (KOER)	4-26
FIGURE 4-27: CONNECT TO DLC "OBDII TEST" SCREEN	4-27
FIGURE 4-28: DLC NOT CONNECTED REASON - OBDII	4-28
FIGURE 4-29: OBDII TEST IN PROGRESS	4-29
FIGURE 4-30: TEST IN PROGRESS CONT.	4-30
FIGURE 4-31: EMISSIONS TEST COMPLETE.....	4-31
FIGURE 4-32: GAS CAP CHECKLIST (GAS CAP TEST)	4-32
FIGURE 4-33: MULTIPLE CAP CHECK (GAS CAP TEST)	4-34
FIGURE 4-34: TEST COMPLETE (GAS CAP TEST)	4-35

NEW JERSEY OPERATORS INSTRUCTION MANUAL

INTRODUCTION

FIGURE 4-35: MISCELLANEOUS EMISSIONS TEST	4-36
FIGURE 4-36: CLARIFICATION (EMISSIONS CLARIFICATION)	4-37
FIGURE 4-37: ENTER INSPECTION FEE SCREEN	4-38
FIGURE 4-38: INSPECTION STATUS "PRINTING VIR" SCREEN	4-39
FIGURE 4-39: MAIN MENU SCREEN.....	4-40
FIGURE 4-40: VEHICLE INSPECTION MENU.....	4-1
FIGURE 4-41: REPRINT VIR WEBSITE	4-2
FIGURE 4-42: VEHICLE INSPECTION MENU.....	4-1
FIGURE 4-43: DLC VEHICLE INFORMATION ENTRY MENU	4-2
FIGURE 4-44: DLC LOCATION MAP	4-3
FIGURE 5-1: MAIN MENU SCREEN	5-1
FIGURE 5-2: DIAGNOSTIC TEST MENU SCREEN.....	5-2
FIGURE 5-3: START OBDII SCAN SCREEN	5-3
FIGURE 5-4: CONNECT TO DLC SCREEN	5-4
FIGURE 5-5: OBDII SCAN IN PROGRESS SCREEN.....	5-5
FIGURE 5-6: OBDII SCAN RESULTS.....	5-6
FIGURE 5-7: DIAGNOSTIC TEST MENU	5-1
FIGURE 5-8: START OPACITY DIAGNOSTIC TEST	5-2
FIGURE 5-9: TURN OFF ACCESSORIES DIESEL OPACITY TEST SCREEN	5-3
FIGURE 5-10: TEST SELECTION (DIESEL OPACITY TEST)	5-4
FIGURE 5-11: CONNECT SMOKEMETER (DIESEL OPACITY TEST).....	5-5
FIGURE 5-12: START ROLLING ACCELERATION TEST (DIESEL OPACITY TEST)	5-6

NEW JERSEY OPERATORS INSTRUCTION MANUAL

INTRODUCTION

FIGURE 5-13: OPACITY DIAGNOSTIC TEST RESULTS.....	5-7
FIGURE 5-14: TEST SELECTION (DIESEL OPACITY TEST)	5-8
FIGURE 5-15: CONNECT SMOKEMETER (DIESEL OPACITY TEST).....	5-9
FIGURE 5-16: START POWER BRAKE TEST (DIESEL OPACITY TEST)	5-10
FIGURE 5-17: OPACITY DIAGNOSTIC TEST RESULTS (POWER BREAK TEST).....	5-11
FIGURE 5-18: TEST SELECTION (DIESEL OPACITY TEST)	5-12
FIGURE 5-19: START SNAP ACCELERATION TEST (DIESEL OPACITY TEST)	5-13
FIGURE 5-20: OPACITY DIAGNOSTIC TEST RESULTS (SNAP ACCELERATION TEST)	5-14
FIGURE 5-21: DIAGNOSTIC TEST MENU	5-15
FIGURE 5-22: ENTER VEHICLE INFO (GAS DIAGNOSTIC TEST)	5-16
FIGURE 5-23: GAS EMISSIONS READING START	5-17
FIGURE 5-24: ZERO CALIBRATION (GAS DIAGNOSTIC TEST)	5-18
FIGURE 5-25: TURN OFF ZERO AIR CYLINDER MESSAGE	5-19
FIGURE 6-1: MAIN MENU SCREEN.....	6-2
FIGURE 6-2: LOG IN SCREEN - SCAN OR ENTER BADGE/ACCESS CODE	6-3
FIGURE 6-3: CALIBRATION/CHECK MENU SCREEN	6-4
FIGURE 6-4: VERIFY PRINTING "PRINTER AND BARCODE SCANNER CHECK" SCREEN	6-5
FIGURE 6-5: SCAN 1D BARCODE "PRINTER AND BARCODE SCANNER CHECK" SCREEN.....	6-6
FIGURE 6-6: RESULTS "PRINTER AND BARCODE SCANNER CHECK" SCREEN	6-7
FIGURE 6-7: COMPLETING CALIBRATION COMPLETED MESSAGE	6-8
FIGURE 7-1: MAIN MENU SCREEN	7-10
FIGURE 7-2: UTILITIES MENU	7-11

NEW JERSEY OPERATORS INSTRUCTION MANUAL

INTRODUCTION

FIGURE 7-3: DATA FILE REFRESH SCREEN.....	7-12
FIGURE 7-4: WORKSTATION STATUS SCREEN	7-13
FIGURE 7-5: PRINTER SETUP SCREEN OPTION	7-14
FIGURE 7-6: REQUEST REMOTE HELP SCREEN ENTRY.....	7-15
FIGURE 7-7: INTERNET CONNECTION CHECK SCREEN	7-16
FIGURE 7-8: DIAL TONE CHECK SCREEN	7-17
FIGURE 8-1: MAIN MENU SCREEN	8-20
FIGURE 8-2: MESSAGES SCREEN	8-21
FIGURE 9-1: MAIN MENU SCREEN	9-24
FIGURE 9-2: WORKSTATION PASSWORD SCREEN	9-25
FIGURE 9-3: WORKSTATION MANAGEMENT MENU SCREEN.....	9-26
FIGURE 9-4: DATA FILE REFRESH SCREEN.....	9-27
FIGURE 9-5: CHANGE WORKSTATION PASSWORD SCREEN	9-28
FIGURE 9-6: EQUIPMENT MAINTENANCE SCREEN	9-29
FIGURE 9-7: SOFTWARE UPDATE FROM CD SCREEN	9-30
FIGURE 9-8: INTERNET ACCESS SETUP SCREEN.....	9-31
FIGURE 9-9: INTERNET CONNECTION CHECK SCREEN	9-32
FIGURE 9-10: SCAN WORKSTATION ID SCREEN	9-33
FIGURE 9-11: SCAN FACILITY ID SCREEN	9-34
FIGURE 9-12: VIEW FACILITY INFORMATION SCREEN.....	9-35
FIGURE 9-13: REPORTS MENU	9-36
FIGURE 9-14: VIEW FACILITY INFORMATION SCREEN.....	9-37

NEW JERSEY OPERATORS INSTRUCTION MANUAL

INTRODUCTION

FIGURE 10-1: MAIN MENU SCREEN.....	10-40
FIGURE 10-2: ERF REPAIR DATA ENTRY LOGIN SCREEN	10-41
FIGURE 11-1: OBDII SCAN IN PROGRESS SCREEN	11-81
FIGURE 13-1: PICTURE AND PICTURE PROMPT USE HANDHELD	13-86
FIGURE 13-2: SCAN VEHICLE VIN BARCODE MESSAGE (PROMPT TO USE HANDHELD)	13-88
FIGURE 13-3: GETTING RPM VALUES (PROMPT TO USE HANDHELD)	13-89
FIGURE 13-4: TEST COMPLETE (HANDHELD MESSAGE)	13-90
FIGURE 13-5: KEY ON ENGINE OFF (KOE0 - HANDHELD MESSAGE)	13-91
FIGURE 13-6: KEY ON ENGINE RUNNING (KOER - HANDHELD MESSAGE)	13-92
FIGURE 13-7: CONNECT TO DLC (HANDHELD MESSAGE)	13-93
FIGURE 13-8: EMISSIONS TEST COMPLETE (HANDHELD MESSAGE)	13-94

NEW JERSEY OPERATORS INSTRUCTION MANUAL

INTRODUCTION

[TABLE OF CONTENTS](#)

CHAPTER 1: INTRODUCTION

Parsons/SGS Testcom Inc. (the Contractor) has developed the NJ2009 Emissions and Safety Inspection System (NJ2009 Workstation) for use in the New Jersey inspection program. The NJ2009 Workstation transfers inspection data to the VID (Vehicle Inspection Database) using the internet. Stations are responsible for providing the internet connection for their workstation (either high speed or dial-up).

The NJ2009 workstation components are a *computer, monitor, keyboard, mouse, printer and cart plus six peripheral devices.*

- First of these devices is the **Bar Code Scanner**. The Bar Code Scanner is used to easily input information into the computer.
- Second, the **OBDII Scan Tool** is used to connect to 1996 and newer vehicles to collect important emission related information from the vehicle's computer.
- Third, a **High speed internet or dial-up internet connection** to connect the NJ2009 to the Contractor computers.
- Fourth, is a **Biometric fingerprint reader** for inspector login.
- Fifth, a **Gas cap tester** to test 2000 and older vehicle gas caps. 2001 and newer vehicle gas caps are tested using the OBDII inspection tests.
- Sixth, the **WiFi antenna**.

NEW JERSEY OPERATORS INSTRUCTION MANUAL

INTRODUCTION

OPTIONAL EQUIPMENT

In addition to the “base unit”, stations may also purchase the optional

- Gas Analyzer
- Diesel Opacity Meter
- Touch Screen Monitor
- Cart Cover

The equipment was designed to provide the most efficient and accurate way to perform inspections and transmit the inspection information to the State.

Future revisions of this manual will be based on the continued development of the system and comments from users. Figures 1.1 thru Figure 1.7 illustrate the NJ2009 workstation components.

NJ2009 WORKSTATION



FIGURE 1-1: NJ WORKSTATION

NEW JERSEY OPERATORS INSTRUCTION MANUAL

INTRODUCTION

LENOVO PC WITH LCD MONITOR, KEYBOARD, AND OPTICAL MOUSE



FIGURE 1-2: LENOVO PC WITH LCD MONITOR, KEYBOARD, AND OPTICAL MOUSE

NEW JERSEY OPERATORS INSTRUCTION MANUAL

INTRODUCTION

LASER PRINTER

The **Lexmark e260d series** laser printer offers high quality output, high speed printing up to 35 pages per minute and 50,000 pages per month duty cycle.



FIGURE 1-3: LEXMARK LASER PRINTER

BAR CODE SCANNER

The **Hand Held Product Honeywell 4600g General Purpose Reader** Bar code scanner features advanced area imaging for improved windshield scanning and support all common 1D and PDF417 symbologies, and has a 15' cord.

NEW JERSEY OPERATORS INSTRUCTION MANUAL

INTRODUCTION



FIGURE 1-4: BAR CODE SCANNER

OBDII INTERFACE MODULE

The **Vetronix OBDII Interface Module** is a ruggedized version of their popular scan tool and includes a heavy-duty Data Link Connector (DLC) cable.



FIGURE 1-5: OBDII INTERFACE MODULE

NEW JERSEY OPERATORS INSTRUCTION MANUAL

INTRODUCTION

GAS CAP TESTER

The **Waekon FPT27 Fuel Cap Tester** features automated testing and includes all adapters.

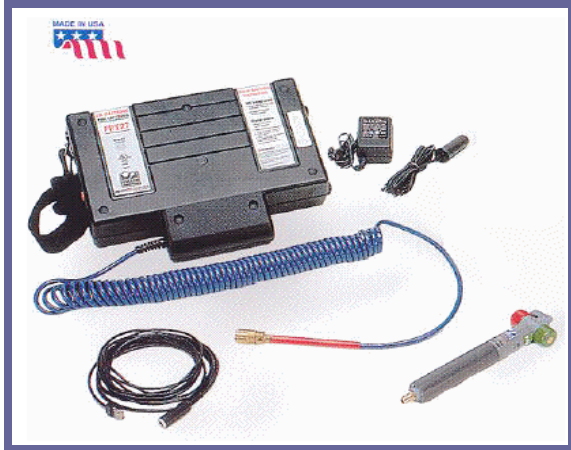

FIGURE 1-6: GAS CAP TESTER

BIOMETRIC FINGERPRINT READER

The **Biometric Fingerprint Reader (Secu Gen Hamster Plus)** this device will be used to identify and authenticate technicians, inspectors and other personnel, features include:

- High-quality, rugged, maintenance-free fingerprint sensor with ultra-precise 500 DPI resolution,
- Auto-on automatically turns on sensor when it detects a finger,
- Smart Capture ensures quality fingerprint scanning of difficult fingers,
- Hardened fingerprint contact area that's resistant to scratches, impact, corrosion and electrostatic discharge (ESD),
- Compact and ergonomically designed to work with any finger or thumb,
- Integrated finger guide,
- Removable, weighted stand, and

NEW JERSEY OPERATORS INSTRUCTION MANUAL

INTRODUCTION

- USB connection.



FIGURE 1-7: BIOMETRIC FINGERPRINT READER

NEW JERSEY OPERATORS INSTRUCTION MANUAL

INTRODUCTION

GENERAL HELP/PHONE NUMBERS

Workstation questions, Inspection procedure questions:

Please Call the NJ2009 **Help Desk at 888-6NJ-2009 (888-665-2009)**.

NJ2009 WORKSTATION HELP

Throughout the NJ2009 Workstation software application, Help Messages are available in critical areas to provide additional information to the operator by pressing the **<F1> key**. On-screen messages will direct you to the correct help function.

ABOUT THIS OPERATORS MANUAL

This manual is intended to provide operating information for new users of the NJ2009 Workstation. Comments about this manual should be directed to the NJ2009 Help Desk at 888-6NJ-2009 (888-665-2009).

SAFETY INFORMATION

WARNING SYMBOLS

Throughout this manual, safety warnings and instructions will be displayed. The symbols below are used to identify information and hazards associated with a procedure or process. Be familiar with these symbols and read the warnings and instructions offered.



This is the electrical warning symbol. It indicates the danger of electrical shock that could result in personal injury to the operator or bystanders.

NEW JERSEY OPERATORS INSTRUCTION MANUAL

INTRODUCTION



WARNING!

A warning indicates a potentially hazardous situation that, if not avoided, could result in death or serious injury to the operator or bystanders. Other symbols inside the triangle may identify specific hazards.

CAUTION!

Caution indicates that a potentially hazardous situation may exist and, if not avoided, could result in moderate or minor injury to the operator or bystanders.

ⓘ Information

The information symbol indicates that helpful information or instructions follow. Pay special attention to this information to avoid damage to the equipment or unnecessary delays.

SAFETY INSTRUCTIONS

RISK OF ELECTRIC SHOCK



Connect the power cord to a properly grounded electrical outlet.

DO NOT remove the power cord-grounding pin.

DO NOT operate electrical equipment around water.

DO NOT operate the NJ2009 equipment during an electrical storm.

DO NOT operate electrical equipment with damaged power cords.

Inspect electrical cords for damage on a regular basis.

NEW JERSEY OPERATORS INSTRUCTION MANUAL

INTRODUCTION

Electric shock can cause serious injury!!!!

RISK OF PERSONAL INJURY



Be aware that many hazardous conditions may exist in the shop environment.

Use caution when in the work area.

Wear Personal Safety Devices (PSD) when you are in the work area.

Keep the work area clean and free from hazards

SYSTEM REQUIREMENTS

Power

- Input – 115 VAC, 60 Hz, \pm 12 volts

Operating Range

- Temperature 35°F to 110°F
- Humidity – 0% – 100%, non-condensing

Internet Connection

- High speed or dial-up internet service
- Local Area Network (LAN) cable with RJ45 or phone line connection
- No firewalls or other device that would restrict access to the internet

NEW JERSEY OPERATORS INSTRUCTION MANUAL

INTRODUCTION

FOR YOUR SAFETY, READ THIS MANUAL THOROUGHLY BEFORE OPERATING THE NJ2009 WORKSTATION. THE INSPECTION EQUIPMENT IS INTENDED TO BE OPERATED BY PROFESSIONAL AUTOMOTIVE TECHNICIANS. PAY SPECIAL ATTENTION TO SAFETY MESSAGES PRESENTED THROUGHOUT THIS MANUAL. THIS MANUAL PROVIDES INFORMATION ABOUT THE PROPER CARE AND SAFE OPERATION OF THE NJ2009 WORKSTATION. IMPROPER OPERATION OF THE EQUIPMENT MAY RESULT IN POSSIBLE DAMAGE TO THE EQUIPMENT AND/OR PERSONAL INJURY.

BEFORE USING THE NJ2009 EMISSIONS AND SAFETY INSPECTION EQUIPMENT, ALWAYS REFER TO AND FOLLOW ALL SAFETY INSTRUCTIONS AND PROCEDURES PROVIDED.

Chapter 2

Main Menu

NEW JERSEY OPERATORS INSTRUCTION MANUAL

MAIN MENU

CHAPTER 2: MAIN MENU

The **NJ2009 Workstation** automatically opens the **Main Menu** when the workstation is powered on. It will take a couple minutes for the software to load before you see the Main Menu Screen.

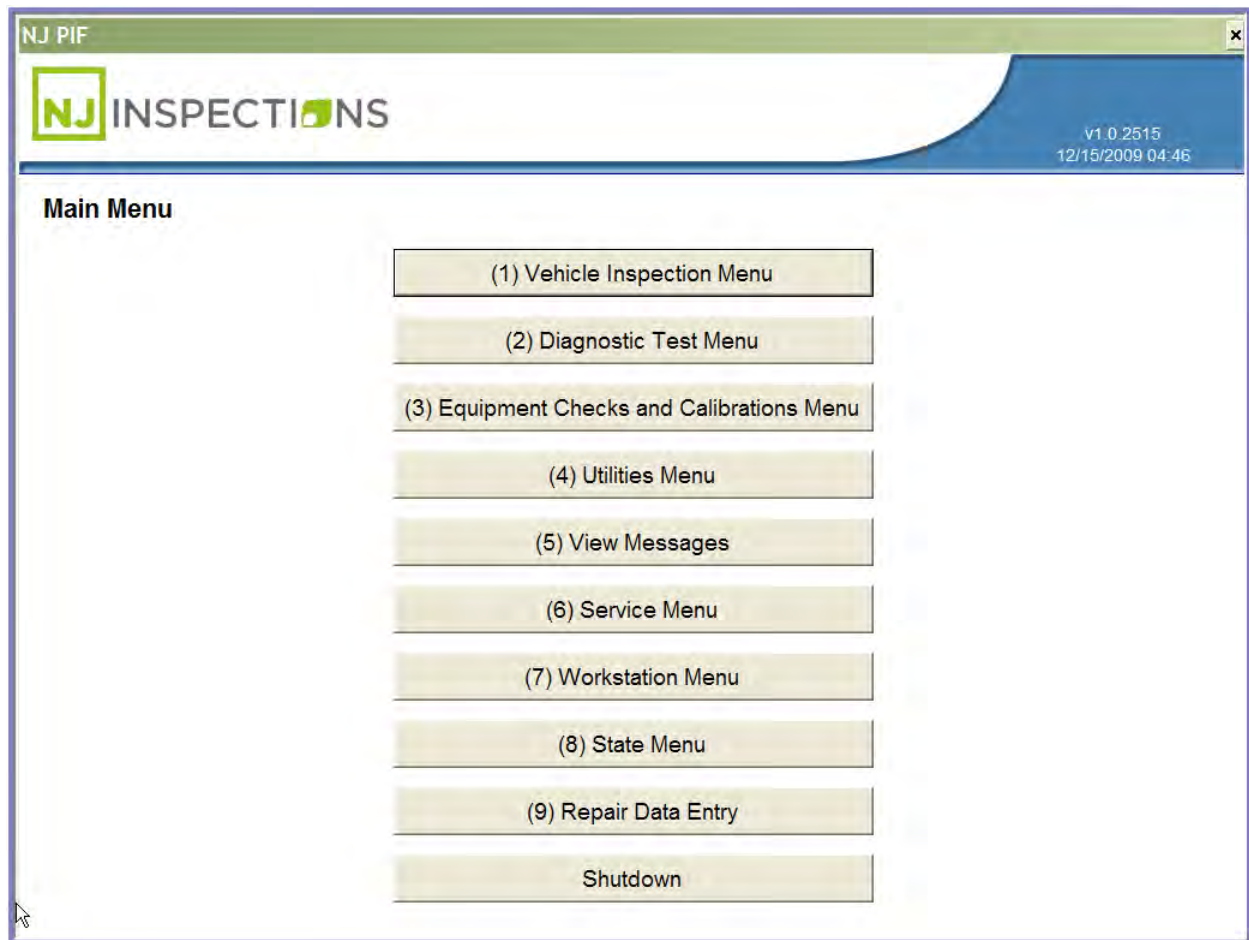

FIGURE 2-1: MAIN MENU

The main menu is comprised of the following menus:

(1) Vehicle Inspection Menu - Access to the following menus:

- (1) Inspection options/ Perform Inspections

NEW JERSEY OPERATORS INSTRUCTION MANUAL

MAIN MENU

- (2) Reprinting VIRs
- (3) Provide replacement stickers
- (4) DLC Locator Reference
- (5) Training features and operator manual

(2) Diagnostic Menu – Access to the following menus:

- Diagnostic OBDII scan tool
- Opacity testing (if equipped for diesel testing)
- Gas emissions testing (if equipped with a gas bench)

(3) Equipment Checks and Calibrations Menu – Access to the following menus:

- (1) Calibrate/check all
- (2) Printer and Barcode scanner check
- (3) Gas Analyzer calibration
- (4) Gas Analyzer leak check
- (5) Gas Cap calibration
- (6) Smoke Meter calibration

(4) Utilities Menu – Access to the following menus:

- (1) Data file refresh
- (2) Workstation status
- (3) Printer setup
- (4) Request remote help

NEW JERSEY OPERATORS INSTRUCTION MANUAL

MAIN MENU

- (5) Check internet connection
- (6) Check for dial tone (if using a dialup internet connection)
- (7) Browse internet
- (8) Calibrate touchscreen (if you purchased a touchscreen)

(5) View Messages – View State and Contractor Messages

(6) Service Menu (Field Service Rep access only)

(7) Workstation Menu – Access to the following menus:

- (1) Perform a data file refresh
- (2) Change the workstation menu access password
- (3) Enter equipment maintenance information
- (4) Update workstation software from a CD
- (5) Setup the workstation internet settings
- (6) Check the internet connection
- (7) Initialize or closeout the workstation
- (8) Print station reports
- View station information

(8) State Menu (State Inspector access only)

(9) Repair Data Entry - Provides a form to enter vehicle emission repair information:

Shutdown - CAUTION! Shuts down the workstation safely. NEVER SHUT DOWN THE WORKSTATION BY UNPLUGGING THE POWER CORD OR SWITCHING OFF THE POWER STRIP BEFORE USING THE SHUTDOWN MENU OPTION AND WAITING FOR THE COMPUTER TO POWER DOWN.

NEW JERSEY OPERATORS INSTRUCTION MANUAL

MAIN MENU

DAMAGE TO WORKSTATION SOFTWARE MAY RESULT. YOU MAY BE BILLED FOR REPAIRS.

TABLE OF CONTENTS

Chapter 3

Workstation

Operation

NEW JERSEY OPERATORS INSTRUCTION MANUAL



WORKSTATION OPERATION

CHAPTER 3: NJ2009 WORKSTATION OPERATION

TURNING THE WORKSTATION ON

1. Connect the power cord to a grounded electrical outlet.
2. Switch the power switch on the back of the workstation to the On position.
The power switch will illuminate.
3. Open the PC access panel located on the front of the workstation.
4. Press the PC power button and release. The green power indicator will illuminate.
5. Verify that the monitor is turned on. The power indicator should be illuminated.
6. Wait for the workstation application to load. This may take a couple minutes. The screen will display a progress bar. When the application is loaded, the Main Menu will be displayed.

WORKSTATION OPERATION CAUTIONS

1.  **NEVER** operate the workstation in a wet area.
2.  **NEVER** operate the workstation with the rear compartment door open.

NEW JERSEY OPERATORS INSTRUCTION MANUAL

WORKSTATION OPERATION

3. **CAUTION! NEVER** unplug the workstation power cord with the PC turned on.
4. **CAUTION! NEVER** unplug the workstation to abort an inspection. System files can be damaged resulting in workstation lockout.
5. **CAUTION! NEVER** turn the PC off with the application running. System files may be damaged resulting in workstation lockout.

SHUTTING DOWN THE WORKSTATION

1. **ⓘ ALWAYS** use the Shutdown selection on the Main Menu to shut down the workstation.

LOADING NEW SOFTWARE

Software updates will usually be downloaded over the internet to your workstation automatically. Follow any instructions displayed when updates are being downloaded. NEVER turn off the PC or unplug the power cord when updates are being downloaded.

In the event a software update cannot be downloaded over the internet, a CD will be provided.

1. Open the PC access door on the front of the workstation.
2. Press the CD drive button to open the CD drawer.
3. Insert the CD and press the CD drive button to close the CD drawer.
4. Select (7) Workstation Menu from the Main Menu.
5. Enter the station password and select OK.
6. Then, select (4) Update Software from CD.

NEW JERSEY OPERATORS INSTRUCTION MANUAL

WORKSTATION OPERATION

7. When the update is complete, remove the CD, and store it for safety. The CD may be needed again if a system re-image is required. Do Not discard the CD.

Chapter 4

Vehicle Inspection Menu (1)

NEW JERSEY OPERATORS INSTRUCTION MANUAL

VEHICLE INSPECTION MENU (1)

CHAPTER 4: VEHICLE INSPECTION MENU (1)

The **NJ2009 Workstation** automatically opens the **Main Menu** when the workstation is powered on. It will take a couple minutes for the software to load.

VEHICLE INSPECTION MENU

STEP 1. Select <(1) Vehicle Inspection Menu>

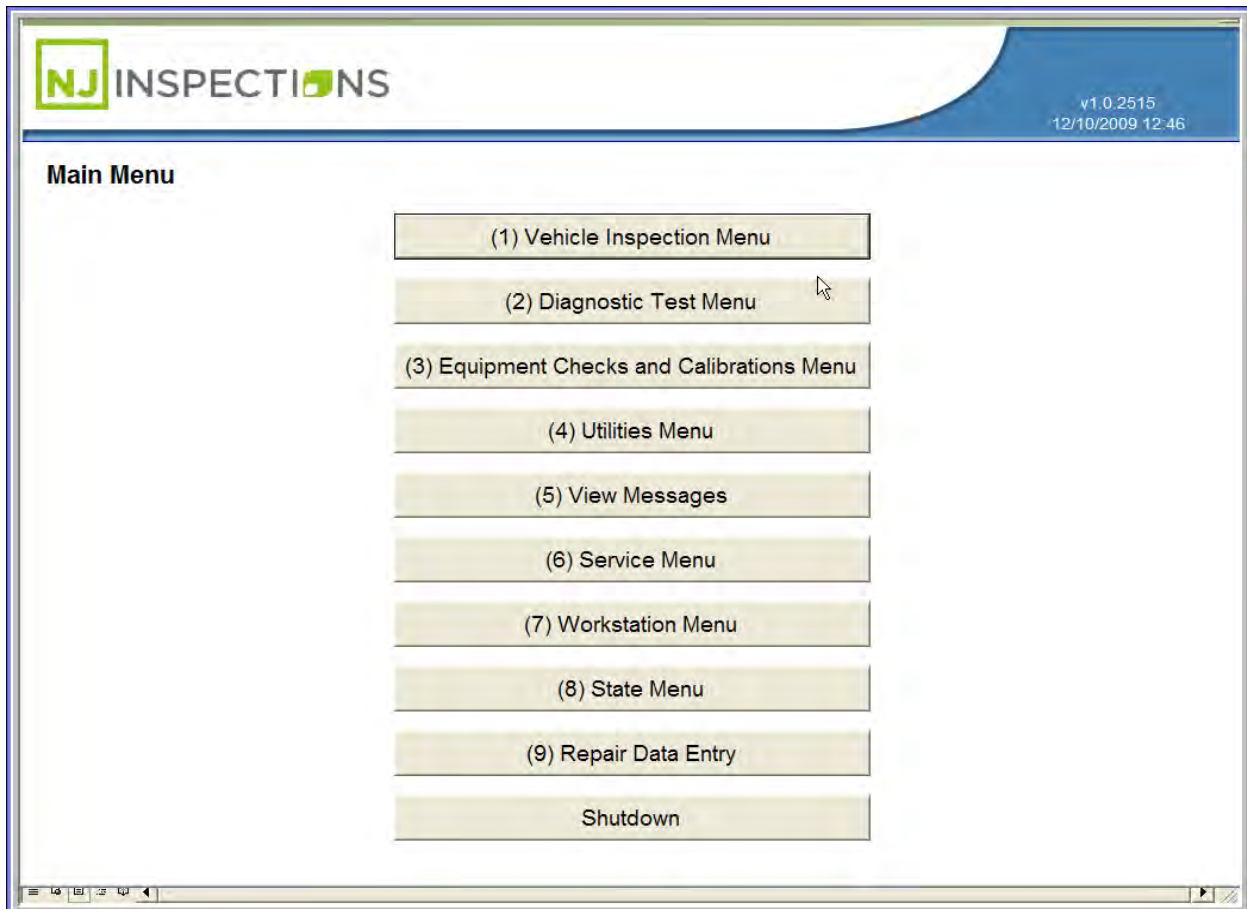

FIGURE 4-1: MAIN MENU

NEW JERSEY OPERATORS INSTRUCTION MANUAL

VEHICLE INSPECTION MENU (1)

(1) PERFORM INSPECTION

STEP 2. Select (1) Perform Inspection from the (1) Vehicle Inspection Menu to perform inspection.



FIGURE 4-2: VEHICLE INSPECTION MENU

NEW JERSEY OPERATORS INSTRUCTION MANUAL

VEHICLE INSPECTION MENU (1)

STEP 3. Follow the screen instructions and **enter or scan your inspector number and access code** or if the fingerprint reader is active, place your index finger on the fingerprint reader screen.

Note, for Bus or other inspection performed at a mobile facility, the application will prompt for inspection location.

STEP 4. Click on **OK** to continue.

The screenshot shows a software window titled "NJ PIF". The header area contains the "NJ INSPECTIONS" logo on the left and the text "v1.0.2515 12/15/2009 01:37" on the right. The main content area is titled "Vehicle Inspection Menu" and features a blue "Please Log In" dialog box. This dialog box contains two numbered input fields: "1. Enter or scan badge number" and "2. Enter your access code". Below these fields are "OK" and "Cancel" buttons. At the bottom of the dialog box, there is a button labeled "(0) Main Menu".

FIGURE 4-3: VEHICLE INSPECTION MENU LOG IN SCREEN MANUAL ENTRY

NEW JERSEY OPERATORS INSTRUCTION MANUAL

VEHICLE INSPECTION MENU (1)

STEP 5. Scan the vehicle VIN barcode

- **Select <Unable to Scan>** if you are unable to scan the vehicle VIN.

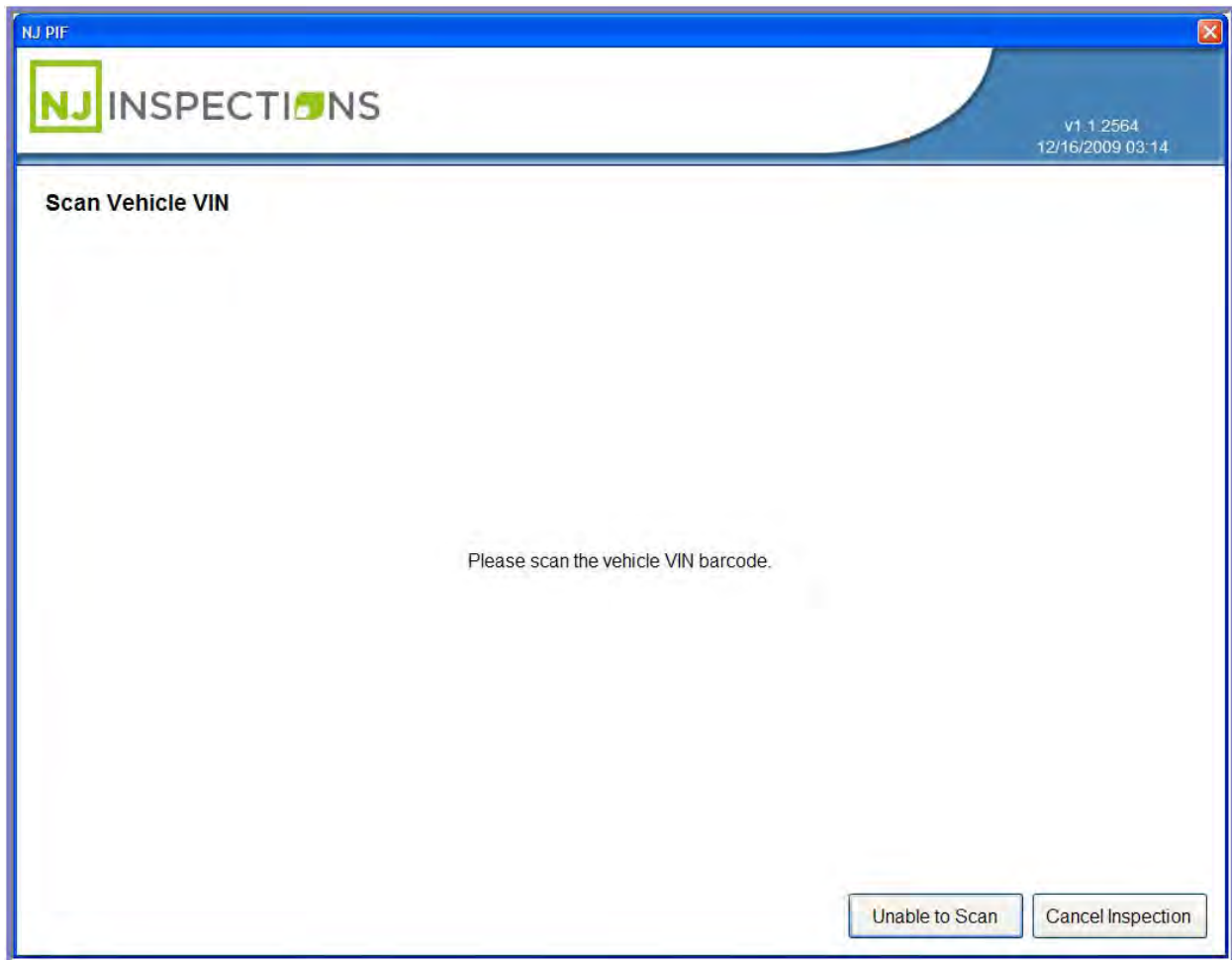
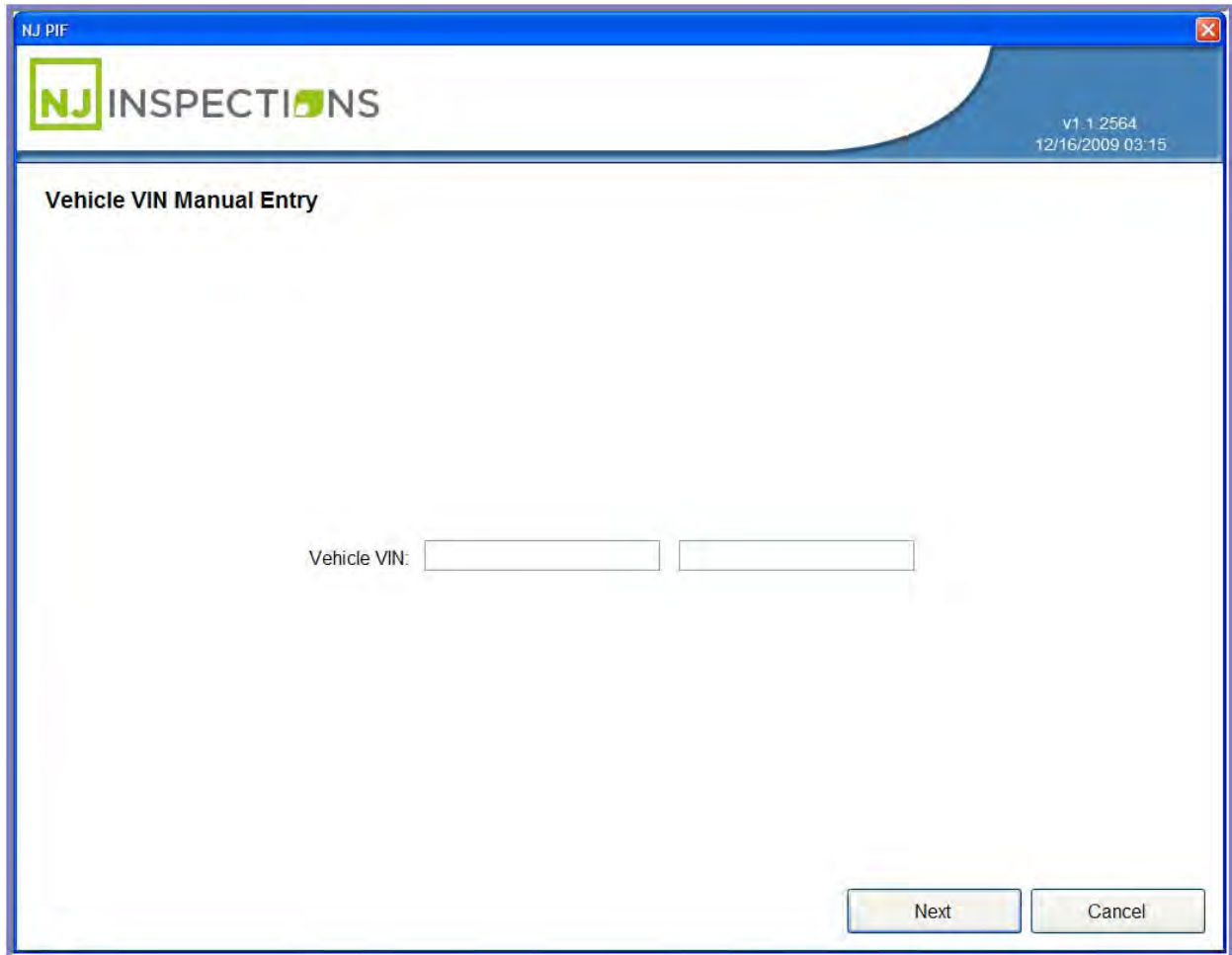

FIGURE 4-4: SCAN VEHICLE VIN SCREEN

NEW JERSEY OPERATORS INSTRUCTION MANUAL

VEHICLE INSPECTION MENU (1)

STEP 6. If unable to scan, enter vehicle VIN information, and **Select <Next>** to continue.



The screenshot shows a software window titled "NJ PIF" with a blue header bar. On the left of the header is the "NJ INSPECTIONS" logo, and on the right is the version information "v1.1.2564" and the date/time "12/16/2009 03:15". The main content area is titled "Vehicle VIN Manual Entry" and contains a label "Vehicle VIN:" followed by two empty text input boxes. At the bottom right of the window are two buttons: "Next" and "Cancel".

FIGURE 4-5: VEHICLE VIN MANUAL ENTRY

NEW JERSEY OPERATORS INSTRUCTION MANUAL

VEHICLE INSPECTION MENU (1)

STEP 7. Scan Registration Document.

- If you are unable to scan the registration barcode or the document is missing, **Select Unable to scan** to enter the VIN manually and continue to **Step 8**.
- Select **Document Missing** and continue to **Step 9**.

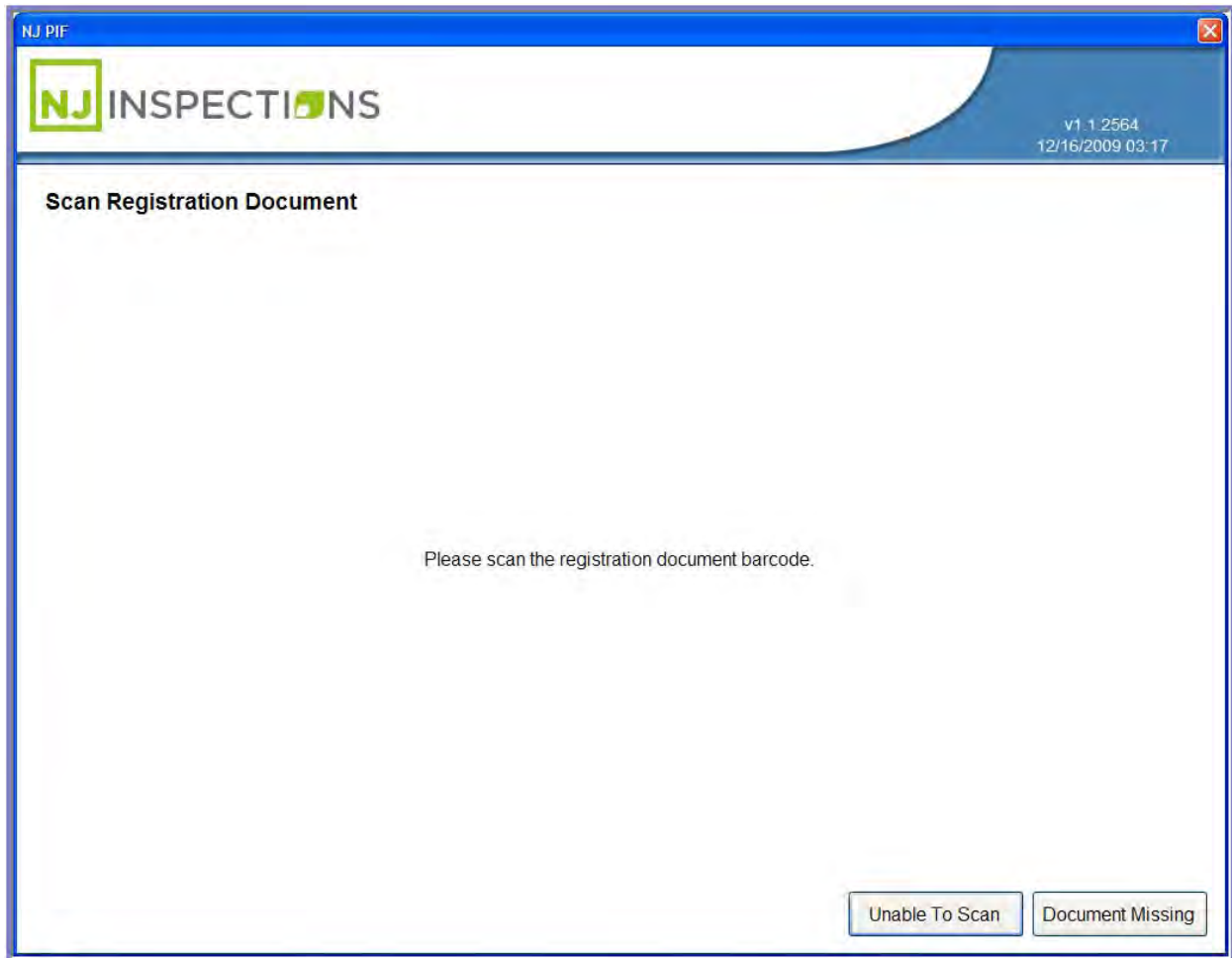

FIGURE 4-6: SCAN VEHICLE REGISTRATION

NEW JERSEY OPERATORS INSTRUCTION MANUAL

VEHICLE INSPECTION MENU (1)

STEP 8. Unable to scan enter document VIN Manually.

NJ PIF

NJ INSPECTIONS

v1.1.2564
12/16/2009 03:17

Document VIN Manual Entry

Document VIN:

Next Cancel

FIGURE 4-7: DOCUMENT VIN MANUAL ENTRY

NEW JERSEY OPERATORS INSTRUCTION MANUAL

VEHICLE INSPECTION MENU (1)

STEP 9. License Plate Manual Entry, Enter License plate number, choose State, and Select <Next> to continue.

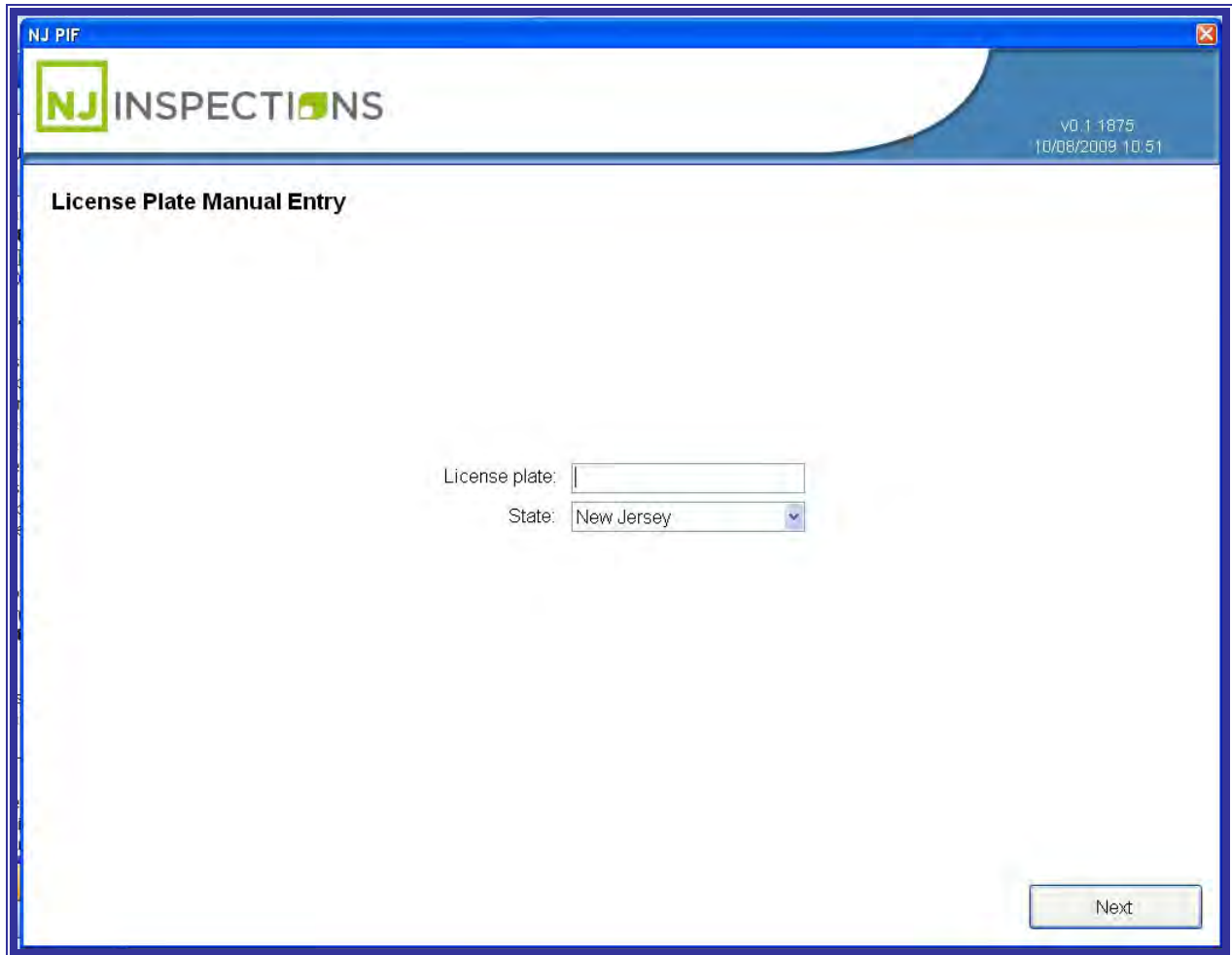

The screenshot shows a software window titled "NJ PIF" with a header bar containing the "NJ INSPECTIONS" logo and version information "v0.1 1875" and "10/08/2009 10:51". The main content area is titled "License Plate Manual Entry" and contains two input fields: "License plate:" with an empty text box, and "State:" with a dropdown menu currently set to "New Jersey". A "Next" button is located in the bottom right corner of the form area.

FIGURE 4-8: LICENSE PLATE MANUAL ENTRY

NEW JERSEY OPERATORS INSTRUCTION MANUAL

VEHICLE INSPECTION MENU (1)

STEP 10. Scan failed VIR barcode if motorist has one.

- For initial inspection, Select **“No failed VIR”**.
- For a reinspection, **Scan the failed VIR**.
- For an abort, **Select “Cancel inspection”**.

STEP 11. Select **“No Failed VIR”** to continue.

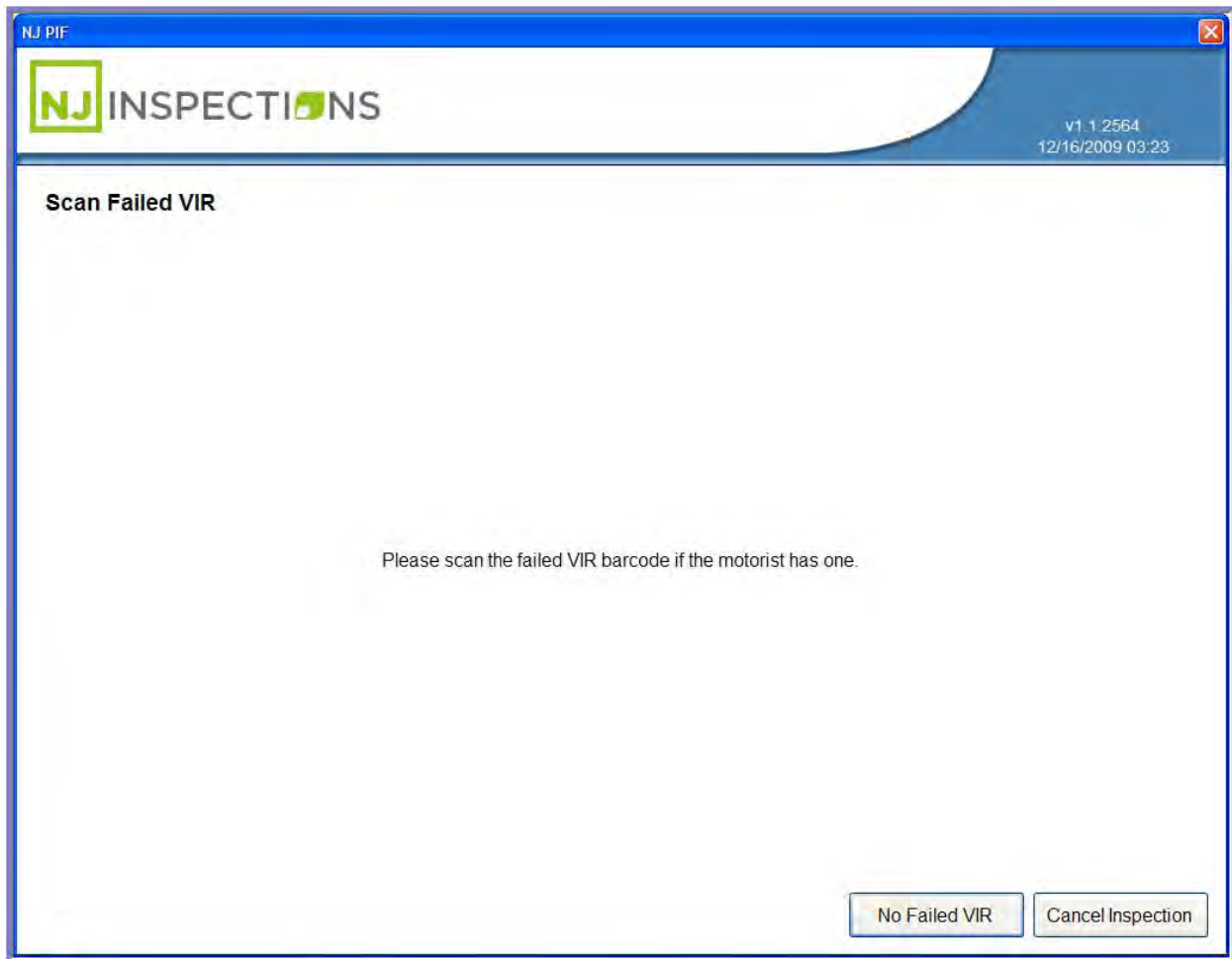
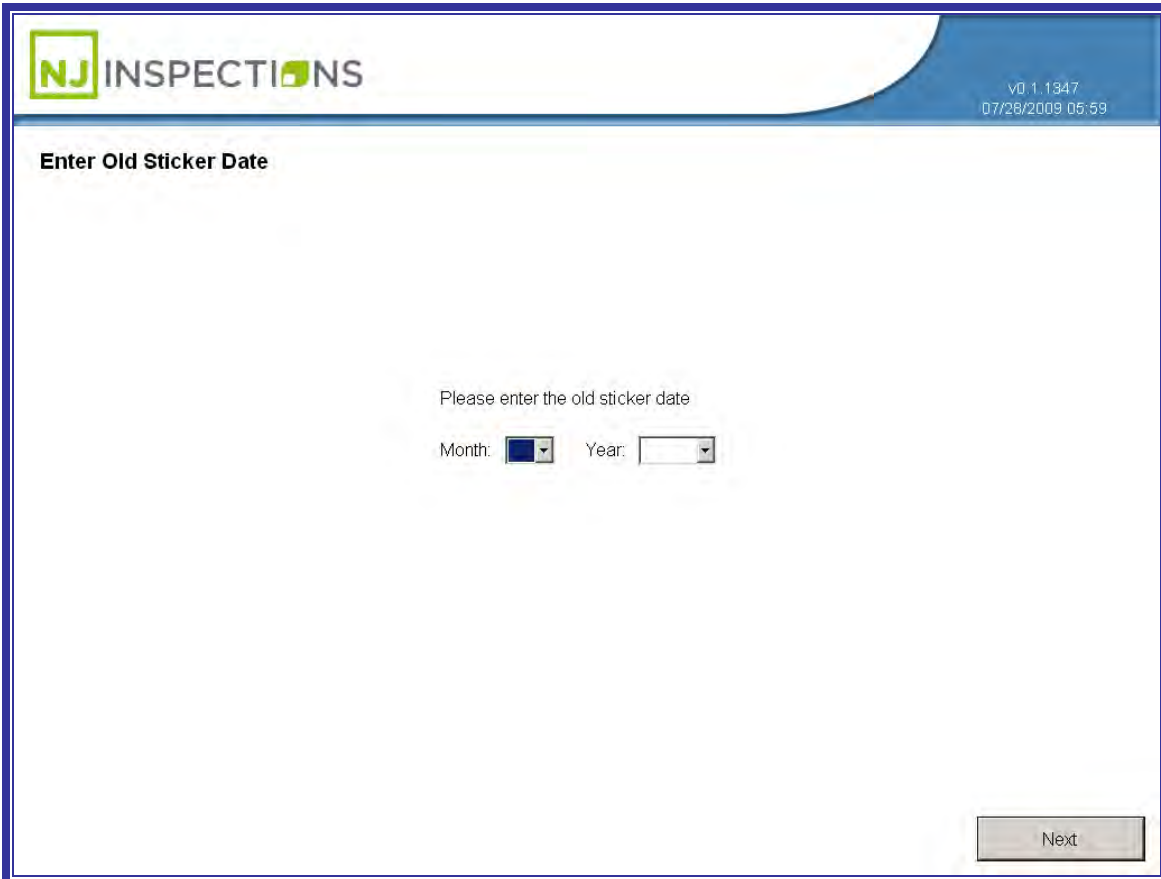

FIGURE 4-9: FAILED VIR CHECK SCREEN

NEW JERSEY OPERATORS INSTRUCTION MANUAL

VEHICLE INSPECTION MENU (1)

STEP 12. Next, **select the month and year** of the old inspection sticker (sticker currently on vehicle). If there is no old sticker, leave the Month and Year blank. Select **Next** to continue.



The screenshot shows a web application interface for 'NJ INSPECTIONS'. The header includes the logo and version information 'v0 1.1347' and a timestamp '07/29/2009 05:59'. The main content area is titled 'Enter Old Sticker Date' and contains the instruction 'Please enter the old sticker date'. There are two dropdown menus: 'Month:' with a blue arrow and 'Year:' with a grey arrow. A 'Next' button is positioned at the bottom right of the form area.

FIGURE 4-10: ENTER OLD STICKER DATE SCREEN

NEW JERSEY OPERATORS INSTRUCTION MANUAL

VEHICLE INSPECTION MENU (1)

STEP 13. Vehicle information is populated, see figure below.

- Enter the **Vehicle information** in the appropriate fields.
- Click **<Next>** to continue to next Step.
- To **Change VIN/Plate** select option and **repeat Step 5 – Step 13.**

The screenshot shows a software window titled "NJ PIF" with the "NJ INSPECTIONS" logo. The window displays a "Vehicle Information" form with the following fields and values:

Vehicle VIN:	19XFA16819E000958	GVWR:	
Document VIN:	19XFA16819E000958	Transmission:	
License plate:	123ABC	Fuel type:	
Model year:	2009	Displacement:	
Make:	HONDA	Units:	LI
Model:	CIVIC	Cylinders:	4
Category:	* Non-Commercial Vehicle (7)	Dual exhaust:	<input type="checkbox"/>
		Odometer:	

At the bottom right of the form, there are two buttons: "Next" and "Change VIN/Plate".

FIGURE 4-11: DOCUMENT VIN MANUAL ENTRY

NEW JERSEY OPERATORS INSTRUCTION MANUAL

VEHICLE INSPECTION MENU (1)

STEP 14. Next, **Selected Tests** are displayed that will be performed. Then select **<OK>** to continue.

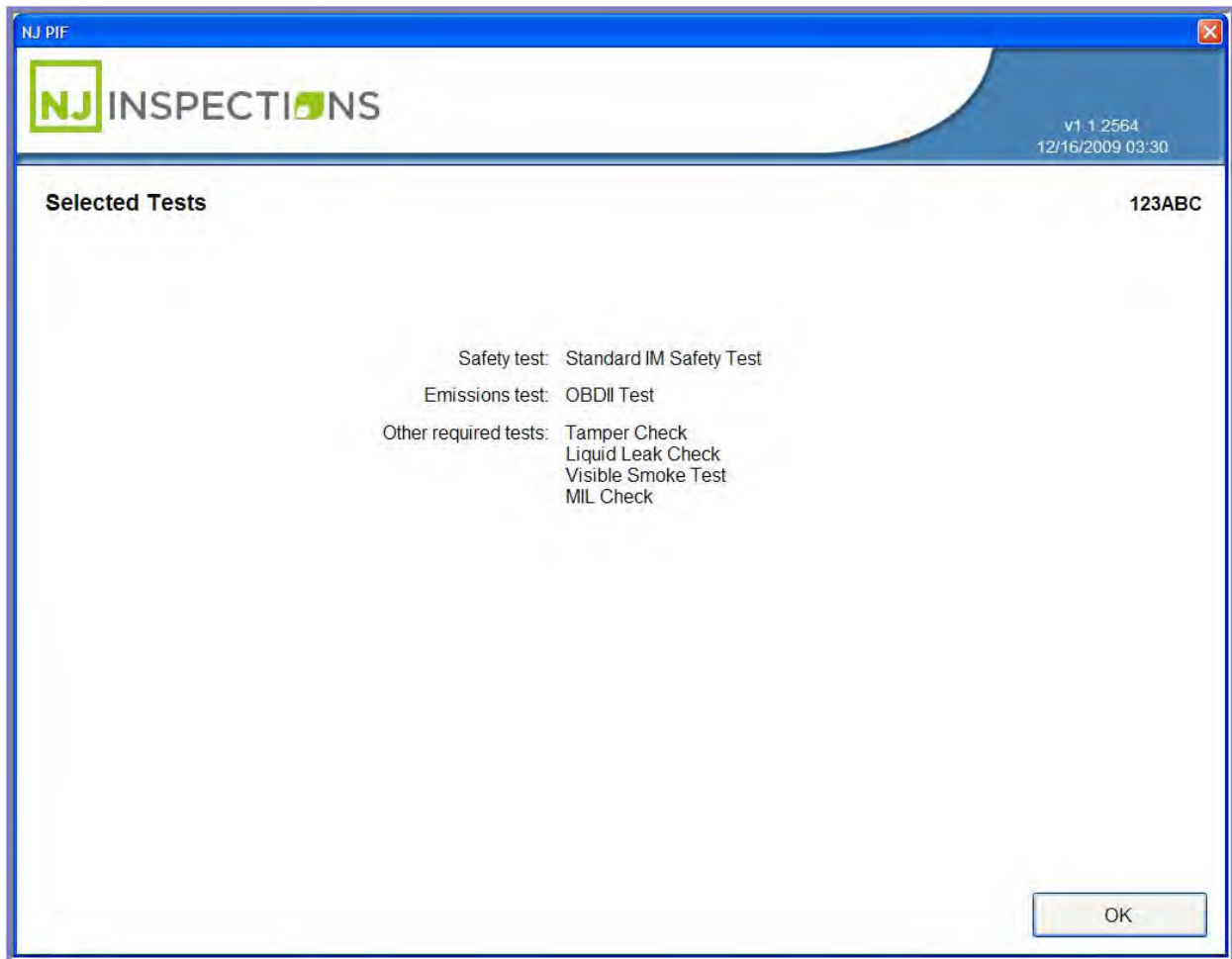

FIGURE 4-12: SELECTED TESTS SCREEN

NEW JERSEY OPERATORS INSTRUCTION MANUAL

VEHICLE INSPECTION MENU (1)

STEP 15. Next, **Summary (Credentials Test)** will be displayed, to change any item from **Pass** to **Fail** select the menu option and make the required change.

(See example on the following page)

STEP 16. If no change is needed select **Complete** to continue to **Step 17**.

The screenshot displays a software window titled "NJ PIF" with a header for "NJ INSPECTIONS". The main content area is titled "Summary Credentials Test" and includes the identifier "123ABC" in the top right corner. The window version is "v1.1.2564" and the date/time is "12/16/2009 03:36". The summary table is as follows:

Item	Status
(1) Driver's License	Pass
(2) Registration	Pass
(3) Insurance Documents	Pass
(4) Plates	Pass
(5) Odometer	Pass

Summary Result: Pass

Complete

FIGURE 4-13: SUMMARY CREDENTIAL TEST SCREEN

NEW JERSEY OPERATORS INSTRUCTION MANUAL

VEHICLE INSPECTION MENU (1)

Example: To change from Pass to Fail, **Select (1) Driver's License** and **Select "Drivers license: Failure"** as in Figure 4-14.

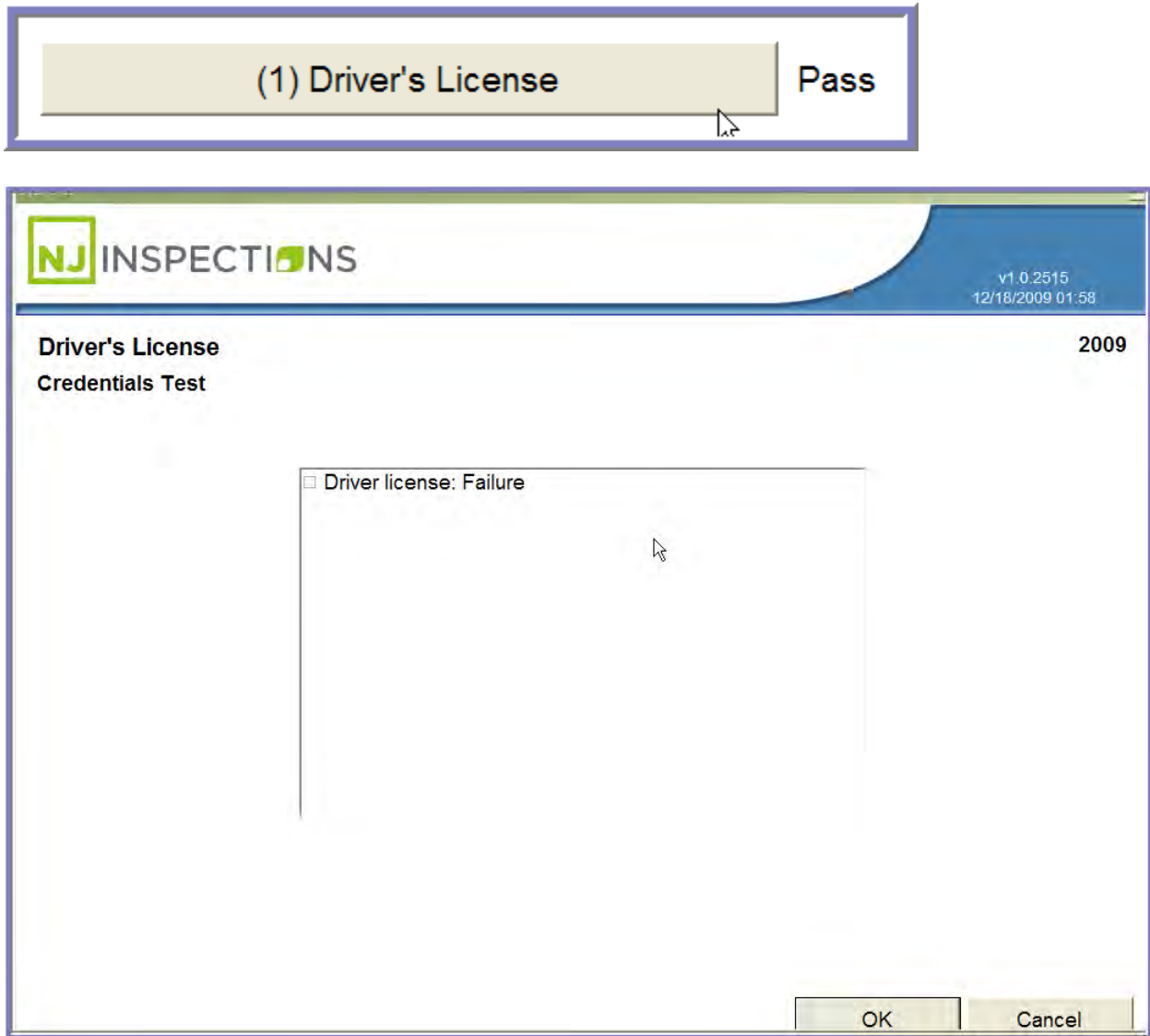

FIGURE 4-14: (1) DRIVER'S LICENSE SUMMARY CREDENTIALS

NEW JERSEY OPERATORS INSTRUCTION MANUAL

VEHICLE INSPECTION MENU (1)

STEP 17. Pre-Test Inspection Standard IM Safety Test is displayed– Inspect the vehicle for any conditions that could be a risk to the operator or vehicle during the inspection and test routines, such as leaking fluids, leaking/broken exhaust system, frayed drive belts, and unusual noises.

- **Are the vehicles safe for testing? Select, Yes or No?**
- **Select <Yes>** and continue to next step.

NJ INSPECTIONS v1.0.2515
12/18/2009 02:02

Pre-Test Inspection 2009
Standard IM Safety Test

Inspect the vehicle for any conditions that could be a risk to the operator or vehicle during the inspection and test routines, such as leaking fluids, leaking/broken exhaust system, frayed drive belts, and unusual noises.

Is the vehicle safe for testing?

Yes No

FIGURE 4-15: PRE-TEST INSPECTION SCREEN

NEW JERSEY OPERATORS INSTRUCTION MANUAL

VEHICLE INSPECTION MENU (1)

STEP 18. Summary Standard IM Safety Test, select each Safety Test option that does not pass the safety test.

Example: Select - (1) Safety Equipment, and continue to next step.

The screenshot shows a software window titled "NJ PIF" with a logo for "NJ INSPECTIONS". The version and date are "v1.1.2564 12/16/2009 03:37". The main content area is titled "Summary Standard IM Safety Test" with the identifier "123ABC". It lists six safety test categories, each with a status and a dropdown menu:

Category	Status	Dropdown
(1) Safety Equipment	Pass	
(2) Steering/Suspension	Pass	▼
(3) Brakes	Pass	
(4) Exhaust System	Pass	▼
(5) Miscellaneous	Pass	
(6) Clarification		

A "Complete" button is located at the bottom right of the screen.

FIGURE 4-16: SUMMARY SAFETY TEST SCREEN

NEW JERSEY OPERATORS INSTRUCTION MANUAL

VEHICLE INSPECTION MENU (1)

STEP 19. From the **Safety Equipment Menu** select equipment to change.

Example: Select (1) Lights, go to next step.

The screenshot shows a software window titled "NJ INSPECTIONS" with a version number "v1.0.2515" and date "12/18/2009 02:05". The main content area is titled "Safety Equipment" and "Standard IM Safety Test" with the year "2009" in the top right. Below the title, there are four rows of equipment categories, each with a text box and a dropdown menu:

(1) Lights	Pass
(2) Glass/Mirrors	Pass
(3) Tires/Wheels	Pass
(4) General	Pass

Below these rows, the "Summary Result" is displayed as "Pass". At the bottom right, there are "OK" and "Cancel" buttons.

FIGURE 4-17: SAFETY EQUIPMENT STANDARD IM SAFETY TEST SCREEN

NEW JERSEY OPERATORS INSTRUCTION MANUAL

VEHICLE INSPECTION MENU (1)

STEP 20. **Lights Safety Test**, select all those that apply and click **<OK>** to return to the **Summary Menu above in Step 18**. Then select **<Complete>** to continue to next step.

The screenshot shows a software window titled "NJ INSPECTIONS" with a version number "v1.0.2515" and date "12/18/2009 02:08". The main content area is titled "Lights" and "Standard IM Safety Test" for a "2009" vehicle. A list of light-related issues is displayed with checkboxes:

- Headlights totally inoperative
- Tail lights - both out
- 3rd stoplight is out
- Stop lights - all lights out
- Stop light(s) out or missing
- Turn/warning signal out or missing
- Turn/Warning Lights: other failure
- Marker/Clear/Reflector: Failure
- Wiring/Switches: Failure
- Headlight rejection: left high/low
- Headlight rejection: right high/low
- Headlights: Advisory
- Stop lights: other failure

At the bottom right, there are "OK" and "Cancel" buttons.

FIGURE 4-18: STANDARD IM SAFETY TEST - LIGHTS OPTIONS

NEW JERSEY OPERATORS INSTRUCTION MANUAL

VEHICLE INSPECTION MENU (1)

STEP 21. **Begin Catalytic Converter Visual Inspection (Tamper Check)**, was this vehicle originally equipped with a catalytic converter as manufactured?

Select **Yes** or **No**.

STEP 22. If **Yes**, Select **<Yes>** and continue to **Step 24**.

STEP 23. If **No**, Select **<No>** and continue on to **Step 26**.

The screenshot shows a software window titled "NJ PIF" with a blue header bar. Below the header is the "NJ INSPECTIONS" logo. In the top right corner of the window, the version "v1.1.2564" and date "12/16/2009 03:45" are displayed. The main content area has a title "Begin Catalytic Converter Visual Inspection" and a sub-title "Tamper Check" on the left, and the alphanumeric code "123ABC" on the right. The central text asks, "Was this vehicle originally equipped with a catalytic converter as manufactured?". At the bottom right, there are two buttons labeled "Yes" and "No".

FIGURE 4-19: BEGIN CATALYTIC CONVERTER VISUAL INSPECTION

NEW JERSEY OPERATORS INSTRUCTION MANUAL

VEHICLE INSPECTION MENU (1)

STEP 24. Next, Perform Catalytic Converter Visual Inspection (Tamper Check)

- Is this vehicle equipped with a correctly installed catalytic converter?
- Select **Yes** or **No**.

STEP 25. If **<Yes>** continue on to **Step 26**.

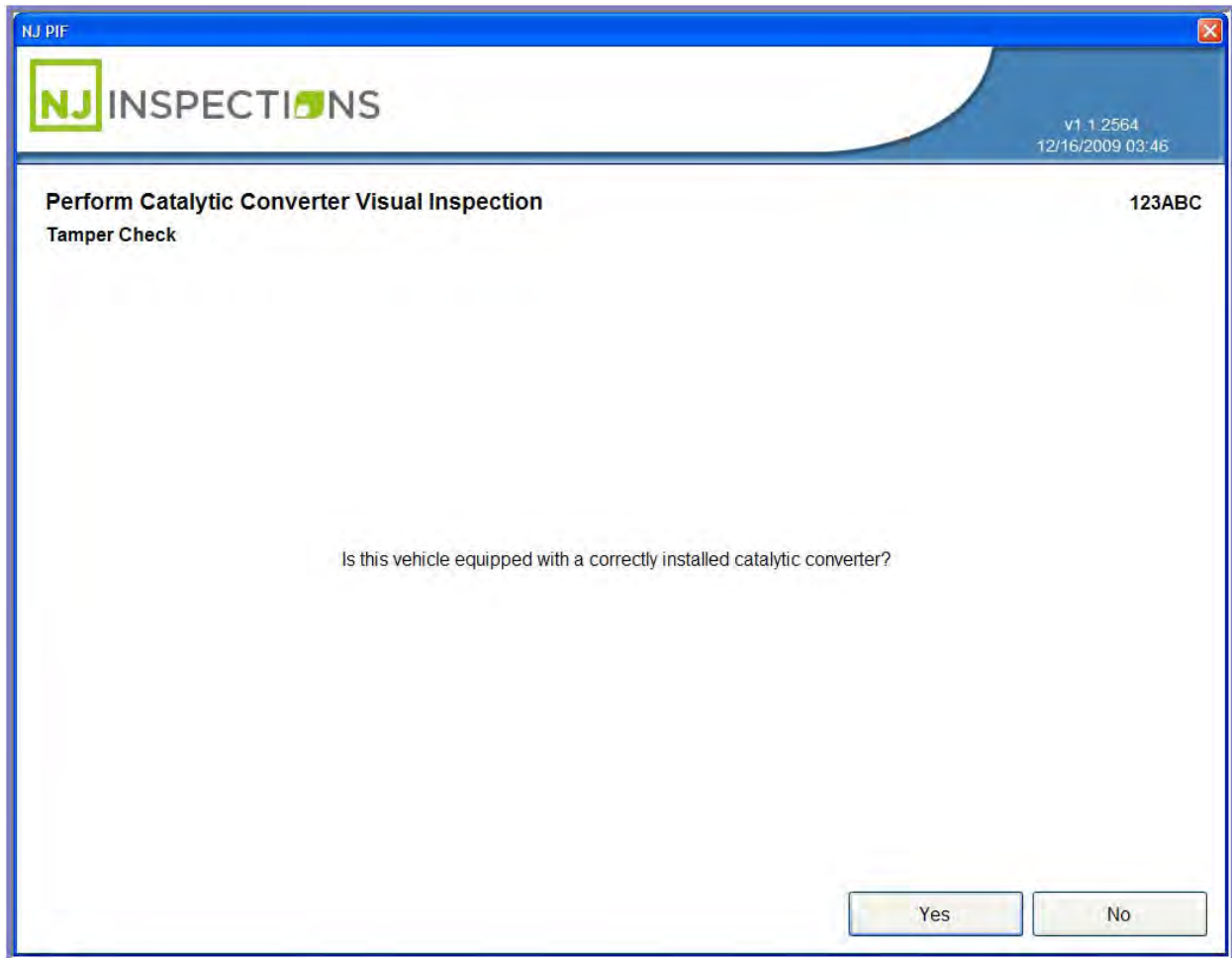

The screenshot shows a software window titled "NJ PIF" with a blue header bar. The header bar contains the "NJ INSPECTIONS" logo on the left and the version information "v1. 1.2564" and "12/16/2009 03:46" on the right. The main content area has a title "Perform Catalytic Converter Visual Inspection" and a subtitle "Tamper Check" on the left, and the alphanumeric code "123ABC" on the right. The central text asks, "Is this vehicle equipped with a correctly installed catalytic converter?". At the bottom right, there are two buttons labeled "Yes" and "No".

FIGURE 4-20: PERFORM CATALYTIC CONVERTER VISUAL INSPECTION

NEW JERSEY OPERATORS INSTRUCTION MANUAL

VEHICLE INSPECTION MENU (1)

STEP 26. Next, Perform Leak Check (Liquid Leak Check).

STEP 27. Examine the vehicle for visible liquid leaks and indicate if the vehicle passes or failed the liquid leak check.

STEP 28. Check for liquid leaks and **select Pass or Fail.**

- Selecting **<Pass>** or **<Fail>** will bring you to the next step.

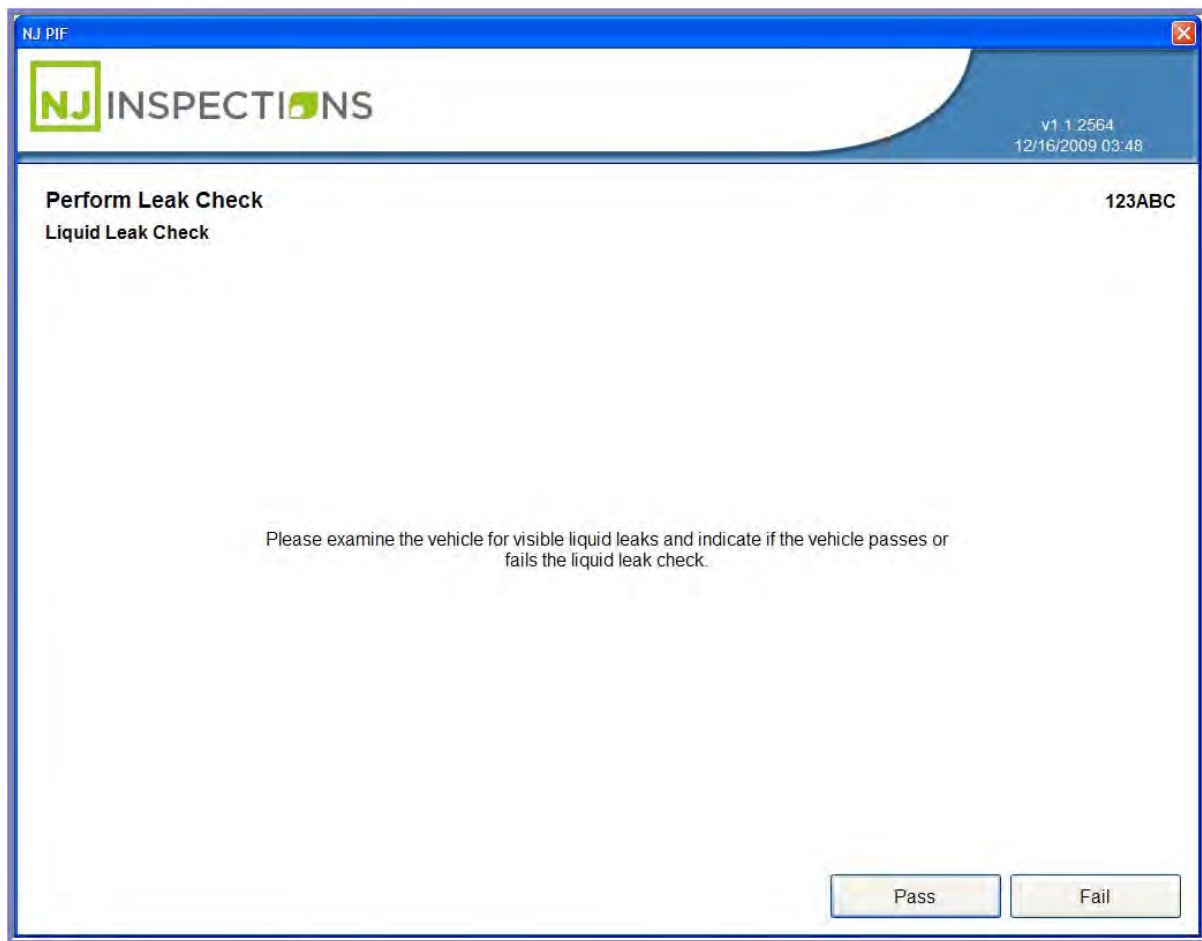

FIGURE 4-21: PERFORM TEST "LIQUID LEAK CHECK" SCREEN

NEW JERSEY OPERATORS INSTRUCTION MANUAL

VEHICLE INSPECTION MENU (1)

STEP 29. Next, **Perform Test (Visible Smoke Test)**. Follow the on screen instructions. If there is visible smoke, **select <Fail>**. If there is no visible smoke, **select <Pass>**.

STEP 30. Selecting **Pass or Fail** will bring you to the next step.

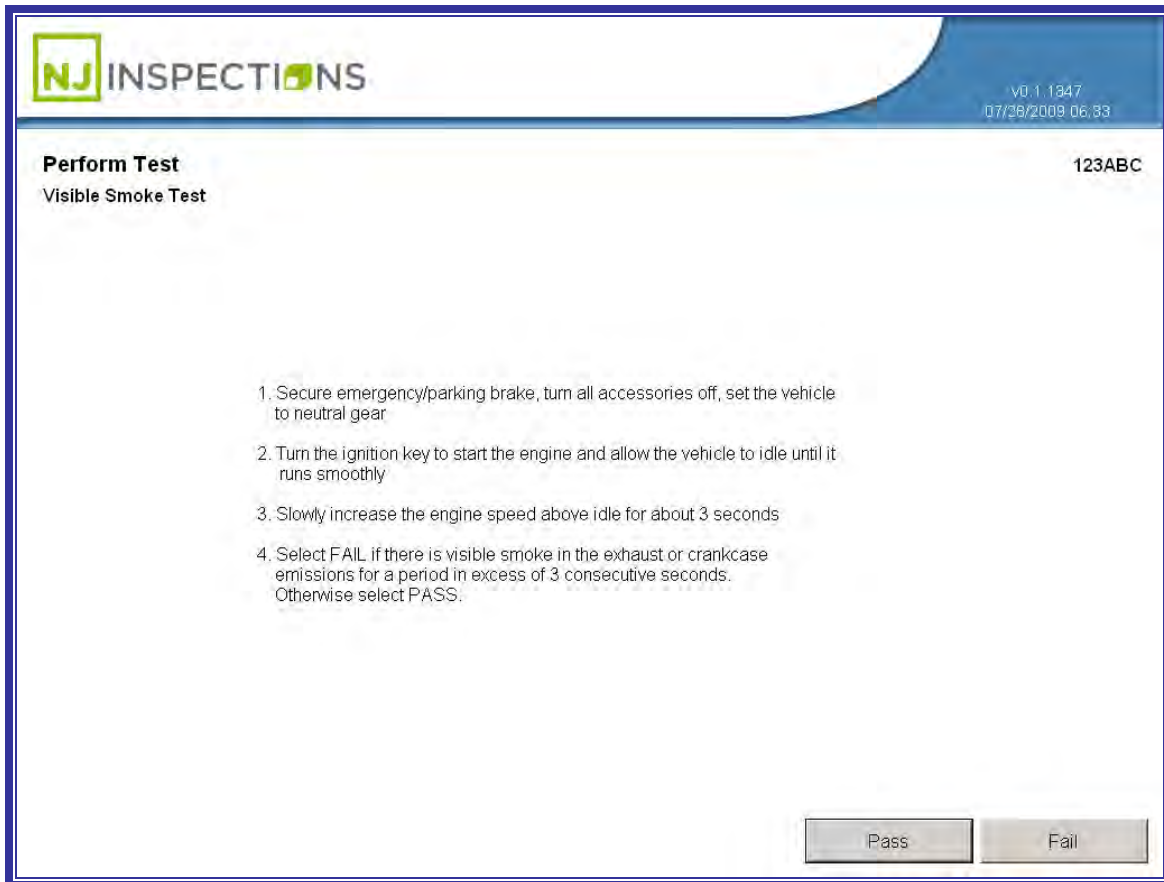

FIGURE 4-22: PERFORM TEST "VISIBLE SMOKE TEST" SCREEN

NEW JERSEY OPERATORS INSTRUCTION MANUAL

VEHICLE INSPECTION MENU (1)

STEP 31. Next, Key On Engine Off (KOEO) MIL Check. Select **Yes** or **No**.

- Select **<Yes>** and continue on to **Step 35**.
- If **No**, continue to **Step 32**.

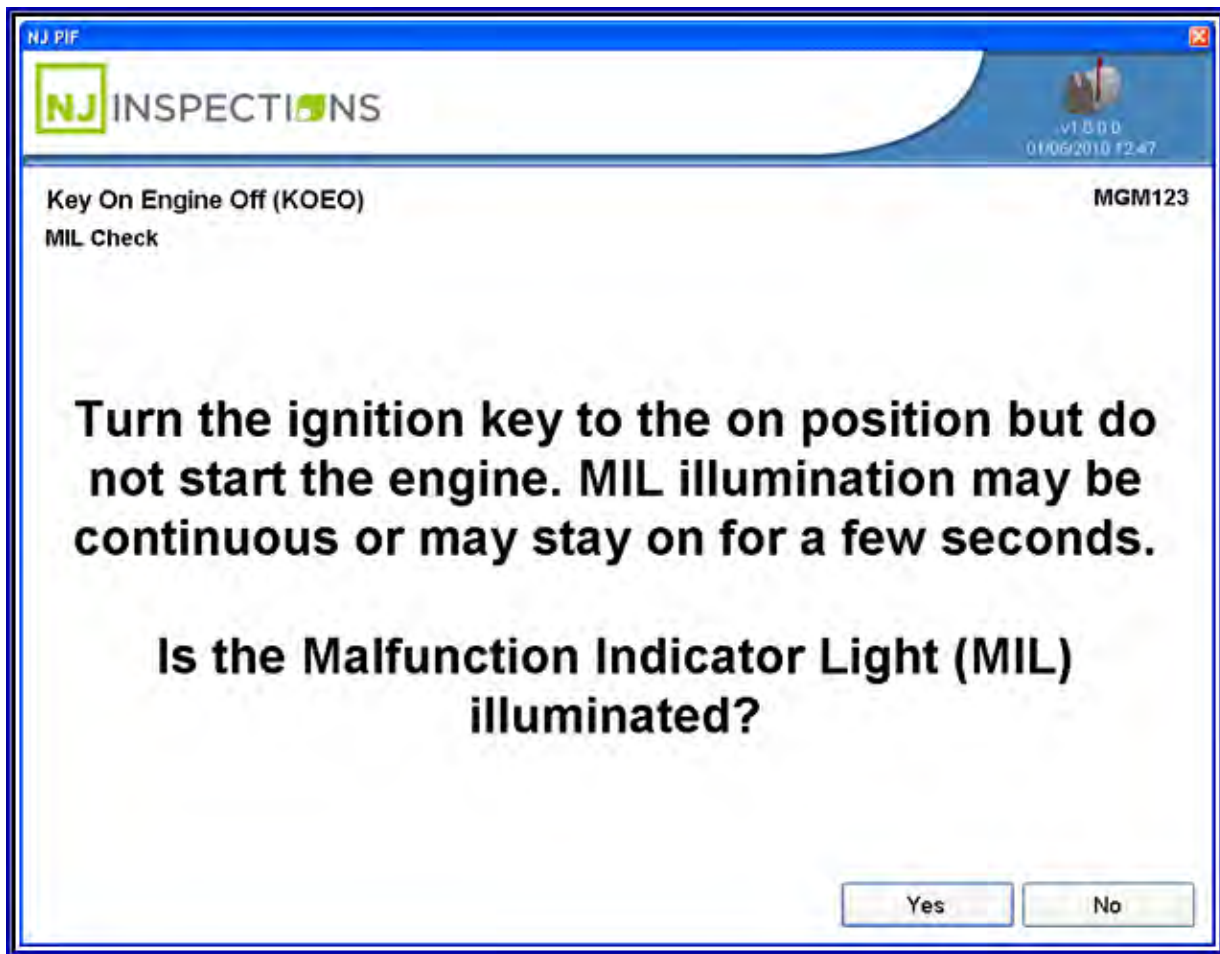

FIGURE 4-23: KEY ON ENGINE OFF (KOEO)

NEW JERSEY OPERATORS INSTRUCTION MANUAL

VEHICLE INSPECTION MENU (1)

STEP 32. Turn Key off MIL Check - MIL Flashing or On, turn the key to off position and press **<Next>** to continue to follow step.

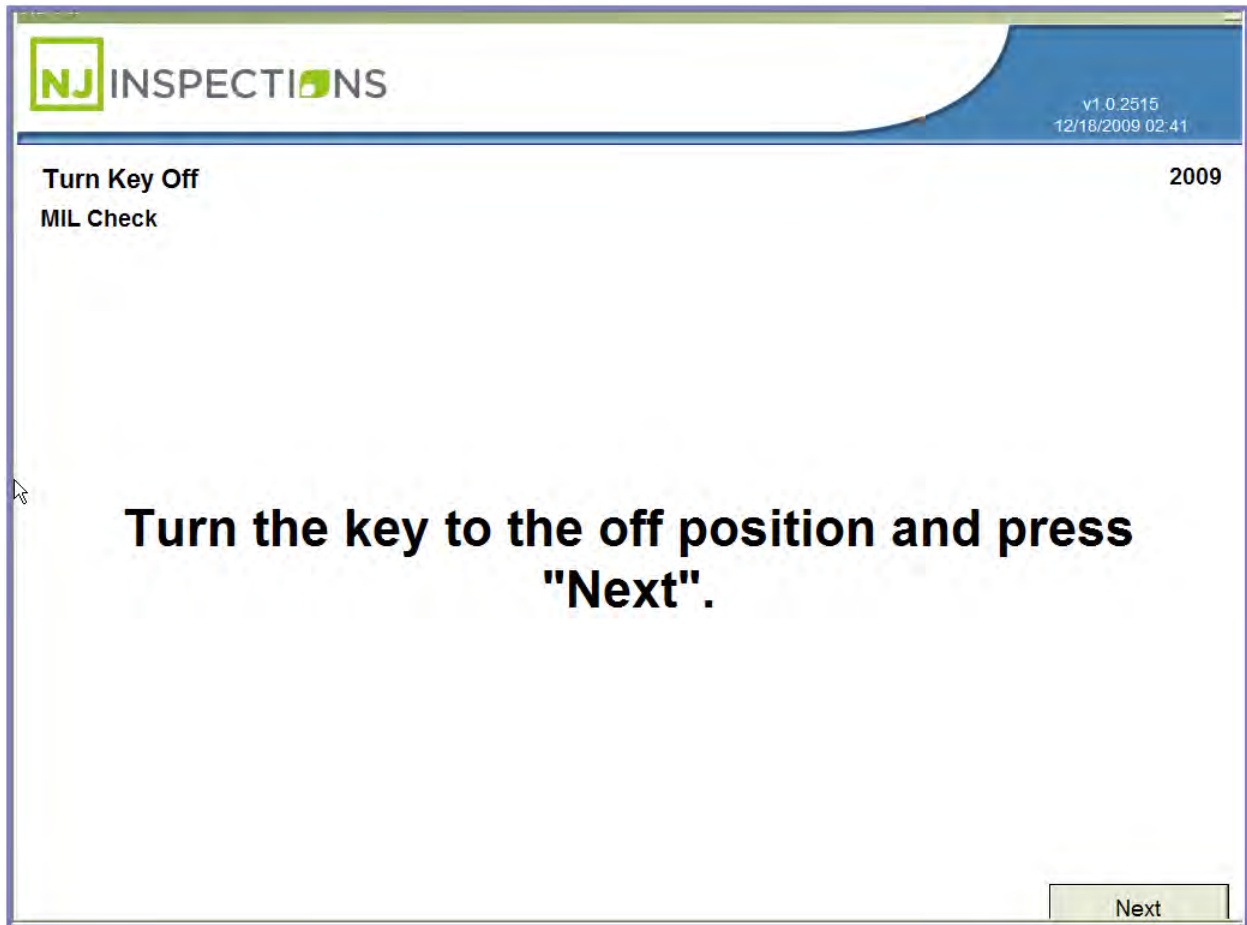

FIGURE 4-24: TURN KEY OFF (MIL CHECK)

NEW JERSEY OPERATORS INSTRUCTION MANUAL

VEHICLE INSPECTION MENU (1)

STEP 33. Next, **Key off Timer MIL Check Screen** will appear to indicate the time needed to keep the key in the off position and wait.

STEP 34. Click **<Next>** and return to **Step 31** “Key On Engine Off (KOEO) MIL Check” screen.

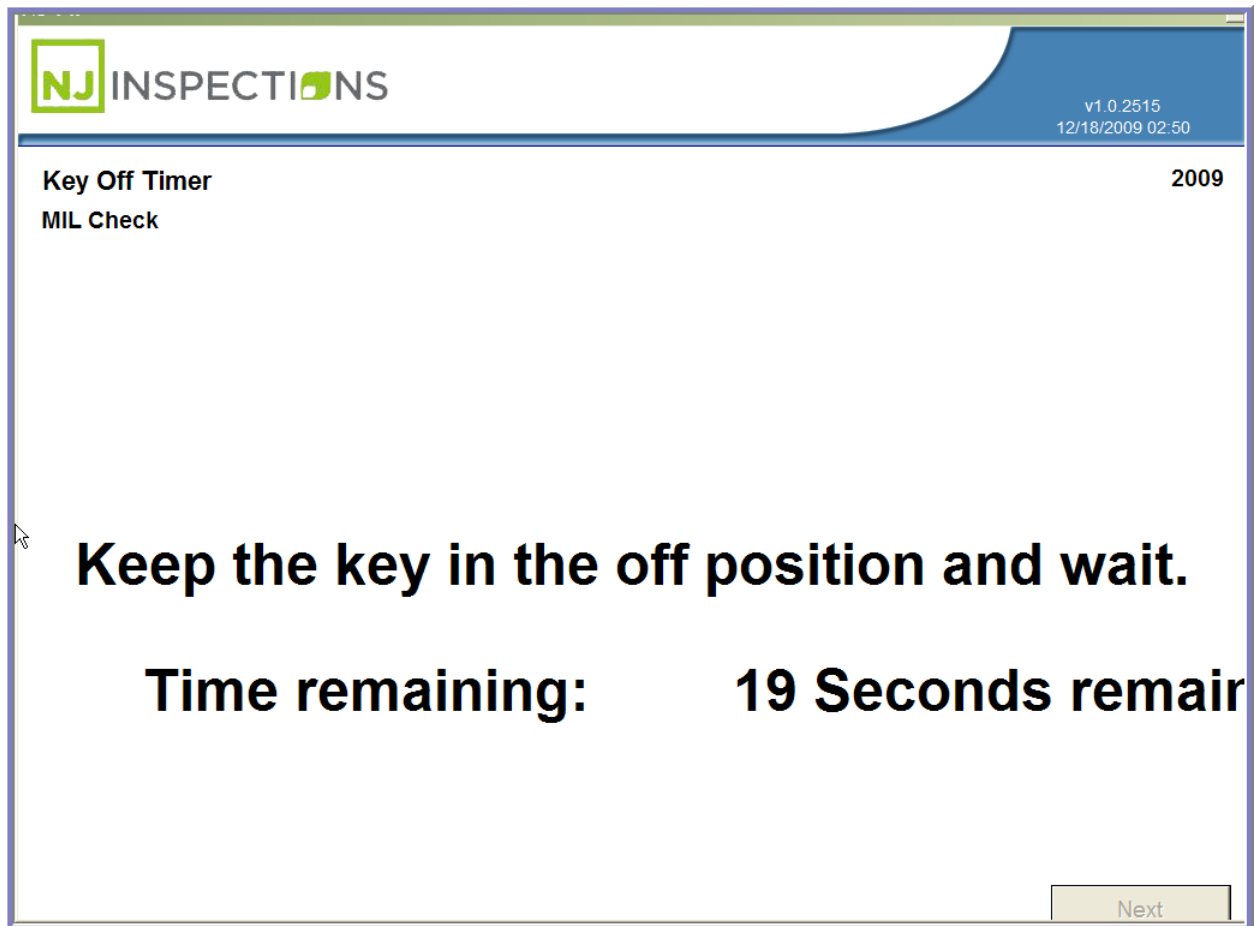

FIGURE 4-25: KEY OFF TIMER (MIL CHECK)

NEW JERSEY OPERATORS INSTRUCTION MANUAL

VEHICLE INSPECTION MENU (1)

STEP 35. Next, Key On Engine Running (KOER) MIL Check.

- Start the engine.
- Did the MIL go out?
- Select **Yes** or **No**.
- Select **<Yes>** to continue to next step.

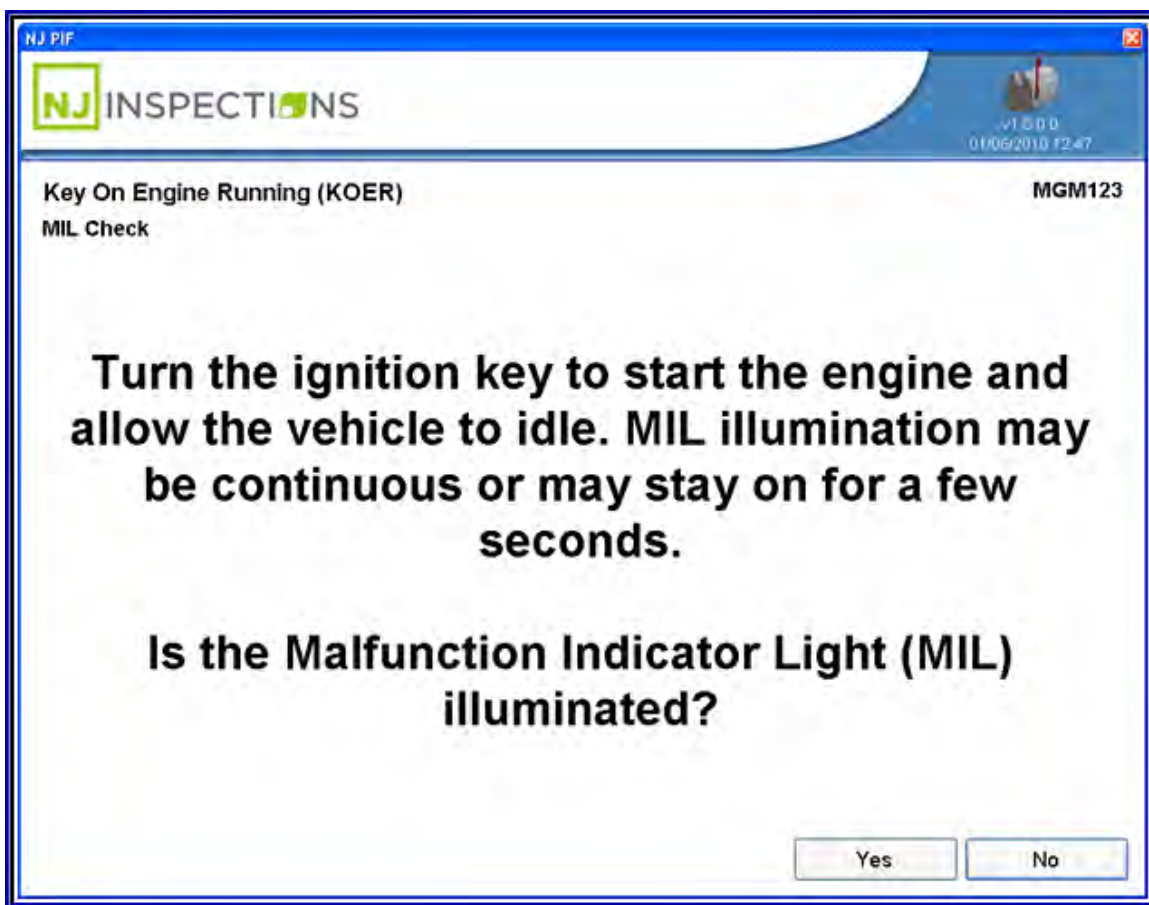

FIGURE 4-26: KEY ON ENGINE RUNNING (KOER)

NEW JERSEY OPERATORS INSTRUCTION MANUAL

VEHICLE INSPECTION MENU (1)

STEP 36. Next, **Connect to DLC** - If the DLC is located and the OBDII scanner cable is connected, **select <Yes>**, and continue to **Step 40**.

- If you can't locate the vehicles DLC connector, press **<F1>** to display the location of the DLC connector.
- If the DLC can't be connected, **select <No>** and continue to **Step 37**.

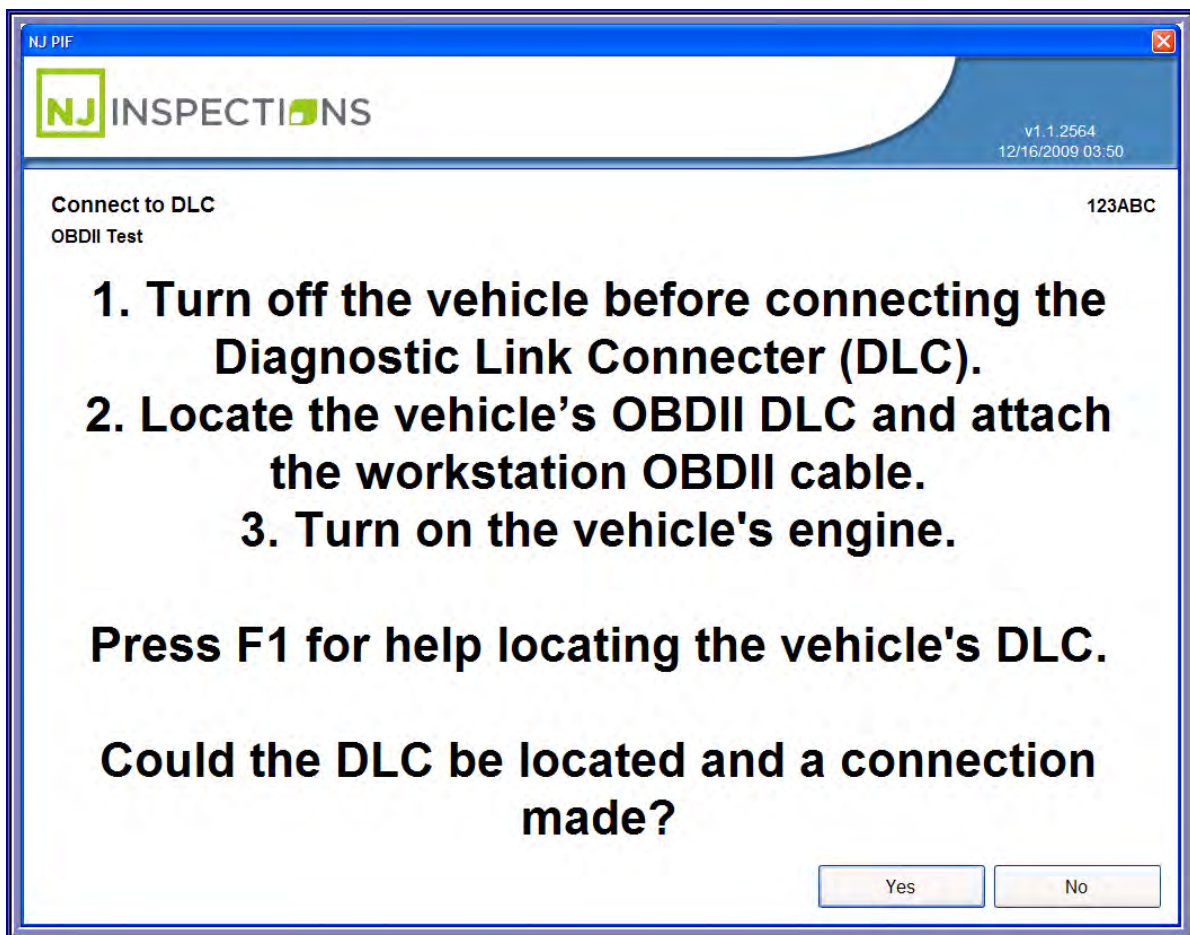

FIGURE 4-27: CONNECT TO DLC "OBDII TEST" SCREEN

NEW JERSEY OPERATORS INSTRUCTION MANUAL

VEHICLE INSPECTION MENU (1)

STEP 37. If **No**, indicate the reason you are unable to connect to the DLC.

STEP 38. Choose from the drop down menu:

- Damaged
- Missing
- Obstructed

STEP 39. Select **<Next>** and continue to **Step 43**.

The screenshot shows a software window titled "NJ INSPECTIONS". In the top right corner, it displays "v1.0.2515" and "12/18/2009 03:17". The main content area is titled "DLC Not Connected Reason" and "OBDII Test" for a "2009" vehicle. Below the title, it says "Please indicate the reason you were unable to connect to the DLC:". A dropdown menu is shown with "Damaged" selected. At the bottom right, there is a "Next" button.

FIGURE 4-28: DLC NOT CONNECTED REASON - OBDII

NEW JERSEY OPERATORS INSTRUCTION MANUAL

VEHICLE INSPECTION MENU (1)

STEP 40. OBDII Test in progress...

- Select **Pass**, **Fail**, **Comm Error**, or **Equipment** to reflect OBD readings.
- If **<Pass>** is selected continue to the next step.

The screenshot shows a software interface for an OBDII test. At the top left is the 'NJ INSPECTIONS' logo. At the top right, it displays 'v1.0.2515' and '12/17/2009 06:19'. Below the header, the text 'Test In Progress' and '11111' is visible. Underneath, 'OBDII Test' is shown. The main area contains a blue box with the question 'What should the subsequent OBD readings reflect?'. At the bottom of this box are four buttons: 'Pass', 'Fail', 'Comm Error', and 'Equipment Fail'.

FIGURE 4-29: OBDII TEST IN PROGRESS

NEW JERSEY OPERATORS INSTRUCTION MANUAL

VEHICLE INSPECTION MENU (1)

STEP 41. Select <Pass>, See test in progress message below.

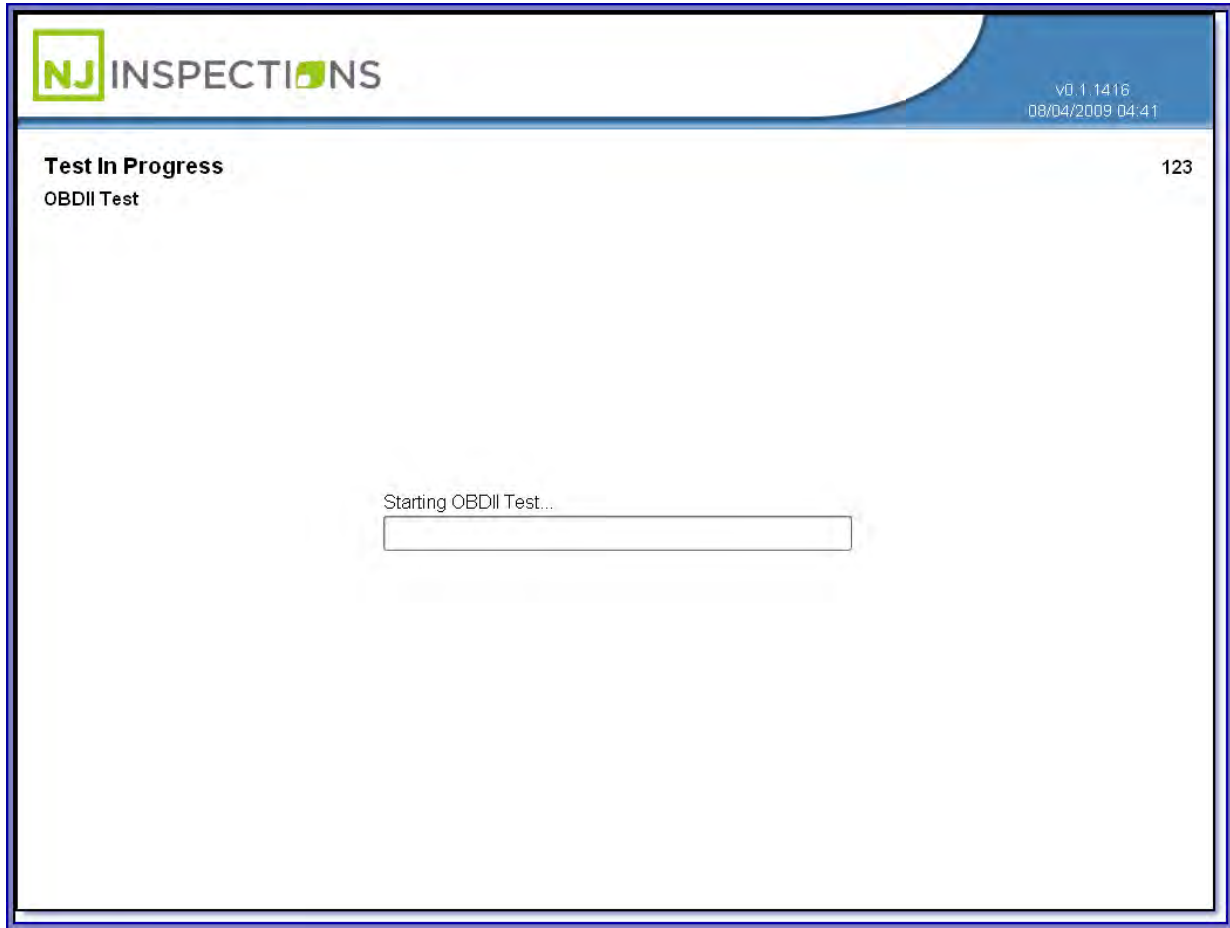

FIGURE 4-30: TEST IN PROGRESS CONT.

NEW JERSEY OPERATORS INSTRUCTION MANUAL

VEHICLE INSPECTION MENU (1)

STEP 42. Emissions test is now complete.

- **Disconnect the OBDII cable** from the vehicle's DLC connector.
- Select **<OK>** to continue.

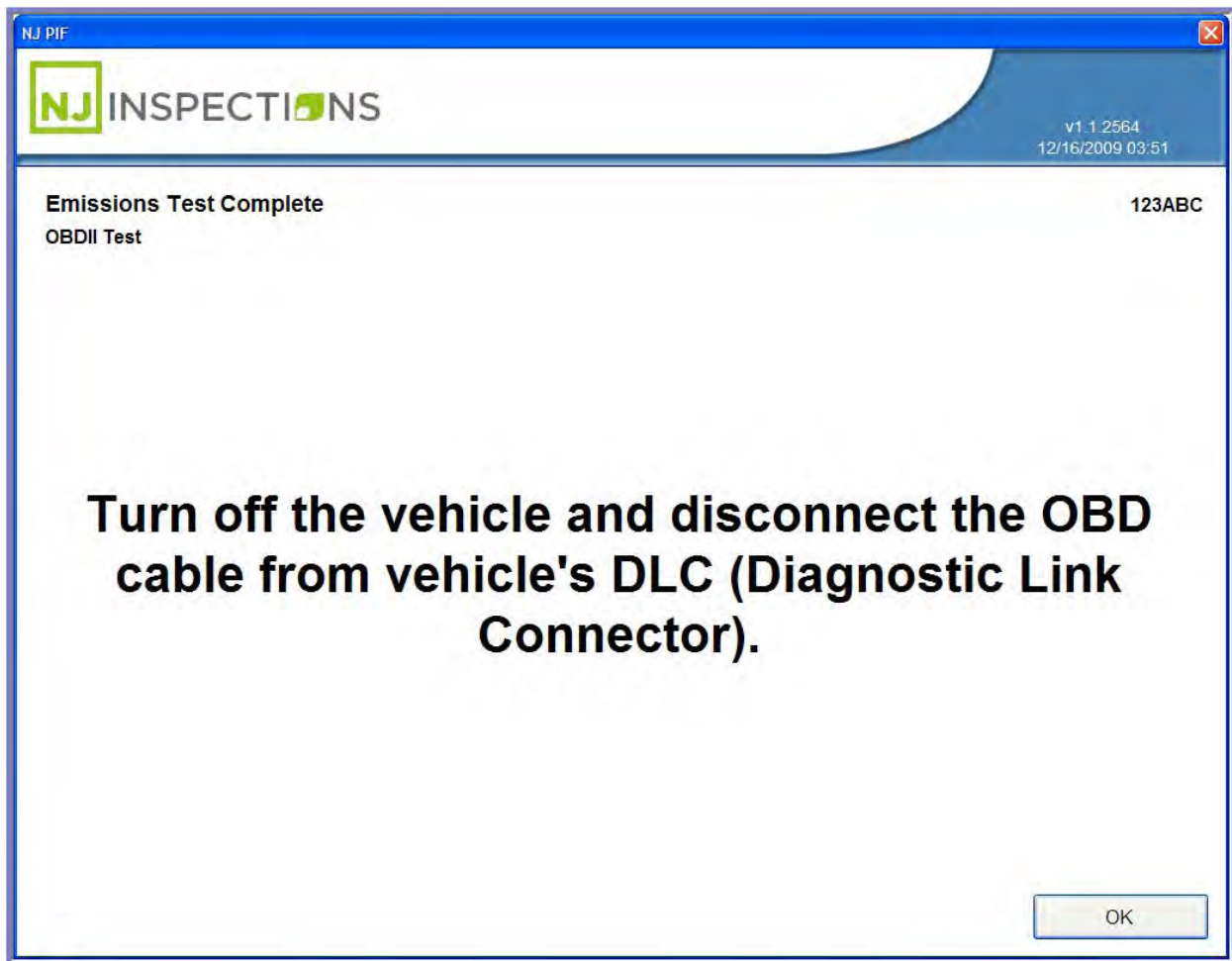

FIGURE 4-31: EMISSIONS TEST COMPLETE

NEW JERSEY OPERATORS INSTRUCTION MANUAL

VEHICLE INSPECTION MENU (1)

STEP 43. Gas Cap Checklist (Gas cap Test)

- Follow Gas Cap test questions on the screen and Select **Yes** or **No**.
- Select **Next** to continue.

NJ INSPECTIONS v1.0.2515
12/18/2009 12:33

Gas Cap Checklist 1234
Gas Cap Test

1. Are all required gas caps present on the vehicle? Yes No

2. Is the gas cap accessible?
(If locked and key is not available, select No) Yes No

3. Can the gas cap be removed?
(If cap is stuck or otherwise unremovable, select No) Yes No

4. Does the gas cap fit an available adapter? Yes No

Gas cap adapter color to be used: No Adapter

Next

FIGURE 4-32: GAS CAP CHECKLIST (GAS CAP TEST)

NEW JERSEY OPERATORS INSTRUCTION MANUAL

VEHICLE INSPECTION MENU (1)

STEP 44. Gas Cap Test In Progress

- Select **Pass**, **Fail**, **Device Error**, or **Timeout** to continue.
- Select **Pass** to continue to next step.

The screenshot shows the NJ INSPECTIONS software interface. At the top left is the logo "NJ INSPECTIONS". At the top right, it displays "v1.0.2515" and "12/18/2009 12:39". The main content area shows "Test in Progress" and "Gas Cap Test" on the left, and the number "1234" on the right. The central question is "Should this gas cap test pass or fail?". Below the question are four buttons: "Pass", "Fail", "Device Error", and "Timeout". At the bottom right of the interface is an "Abort" button.

NEW JERSEY OPERATORS INSTRUCTION MANUAL

VEHICLE INSPECTION MENU (1)

STEP 45. Multiple Gas Cap Check

- If Vehicle has another gas cap to test, **Select Yes**, if not **Select No**.
- If **Yes**, repeat **Steps 35** and **36** above.
- **Select No** if vehicle there are no other Gas Caps and **continue to next step**.

The screenshot shows the 'NJ INSPECTIONS' software interface. At the top left is the logo 'NJ INSPECTIONS'. At the top right, it displays 'v1.0.2515' and '12/18/2009 12:46'. The main content area is titled 'Multiple Cap Check' and 'Gas Cap Test' on the left, and '1234' on the right. The central question is 'Does the vehicle have another gas cap to test?'. At the bottom right, there are two buttons labeled 'Yes' and 'No'.

FIGURE 4-33: MULTIPLE CAP CHECK (GAS CAP TEST)

NEW JERSEY OPERATORS INSTRUCTION MANUAL

VEHICLE INSPECTION MENU (1)

STEP 46. Gas Cap Test Complete

- **If test is complete**, remove the gas cap from the adapter and re-install the gas cap(s) on the vehicle.
- **Select OK** to continue to next step.



FIGURE 4-34: TEST COMPLETE (GAS CAP TEST)

NEW JERSEY OPERATORS INSTRUCTION MANUAL

VEHICLE INSPECTION MENU (1)

STEP 47. Miscellaneous Emissions Test

- Follow instructions on screen and **Select Next** to continue.

NJ INSPECTIONS v1.0.2515
12/17/2009 06:25

Miscellaneous 11111
Misc. Emissions Test

If the vehicle should fail emissions testing for any other reason,
please enter it in the text box below and set the result accordingly.

If not, please leave the result as "Pass" and click "Next".

Comment:

Result:

Next

FIGURE 4-35: MISCELLANEOUS EMISSIONS TEST

NEW JERSEY OPERATORS INSTRUCTION MANUAL

VEHICLE INSPECTION MENU (1)

STEP 48. Clarification Emissions

STEP 49. Follow instructions on screen and **Select Next** to continue.

The screenshot shows a software window titled "NJ INSPECTIONS" in the top left corner. In the top right corner, the version "v1.0.2515" and date "12/17/2009 06:28" are displayed. The main content area is titled "Clarification" and "Emissions Clarification" on the left, with the number "11111" on the right. The central text reads: "If you would like to enter emissions clarification comments for this inspection, you may do so in the space provided." Below this is a text input field labeled "Comment:". A mouse cursor is positioned over the input field. In the bottom right corner, there is a button labeled "Next".

FIGURE 4-36: CLARIFICATION (EMISSIONS CLARIFICATION)

NEW JERSEY OPERATORS INSTRUCTION MANUAL

VEHICLE INSPECTION MENU (1)

STEP 50. Enter the inspection fee. Select **Next** to continue.

NJ PIF

NJ INSPECTIONS

v1.1.2564
12/16/2009 03:52

Enter Inspection Fee

Enter the fee for this inspection

Inspection fee: \$

Next

FIGURE 4-37: ENTER INSPECTION FEE SCREEN

NEW JERSEY OPERATORS INSTRUCTION MANUAL

VEHICLE INSPECTION MENU (1)

STEP 51. Next, the Vehicle Inspection Report (VIR) will print. When the printing is complete, select **OK** to continue.

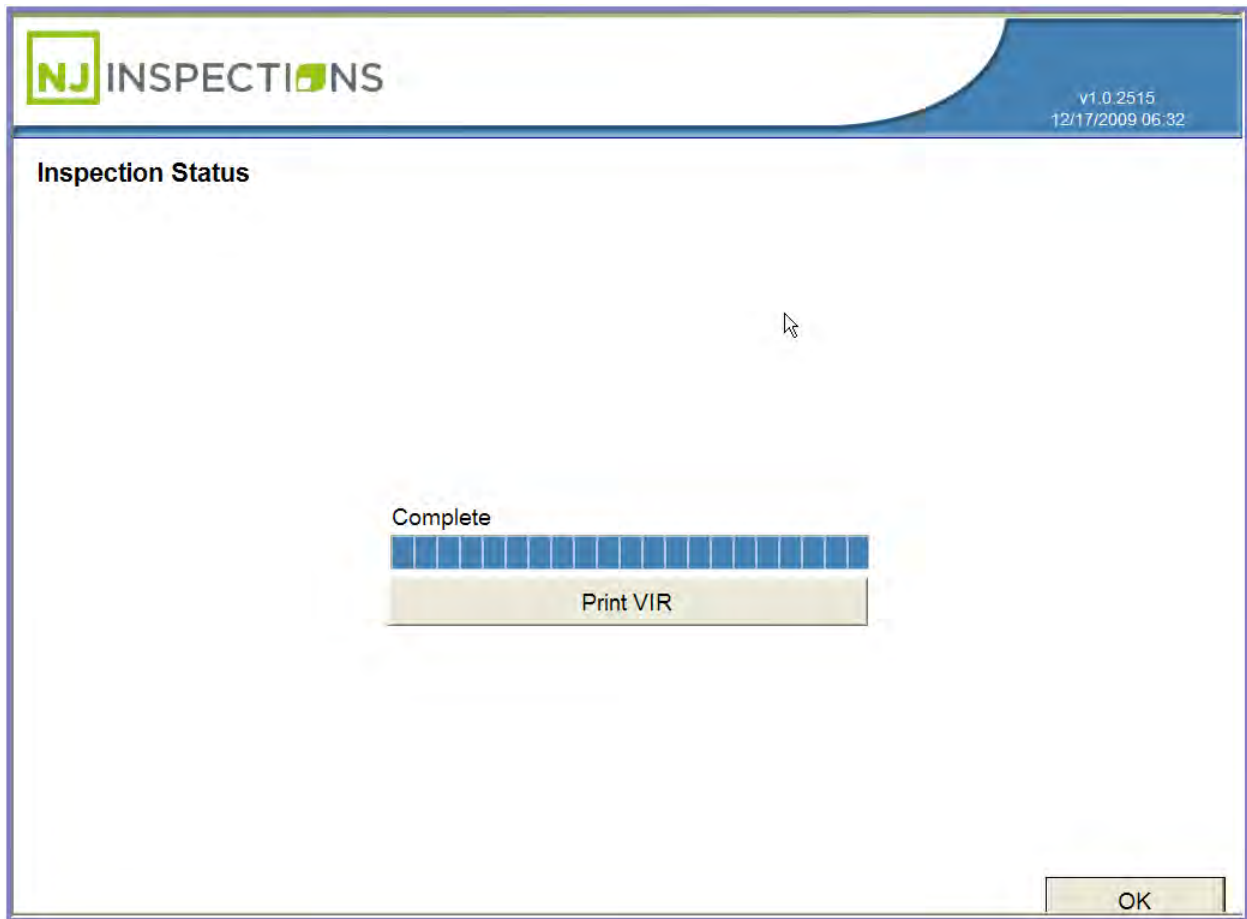

FIGURE 4-38: INSPECTION STATUS "PRINTING VIR" SCREEN

NEW JERSEY OPERATORS INSTRUCTION MANUAL

VEHICLE INSPECTION MENU (1)

The screen will return to the **Main Menu**.

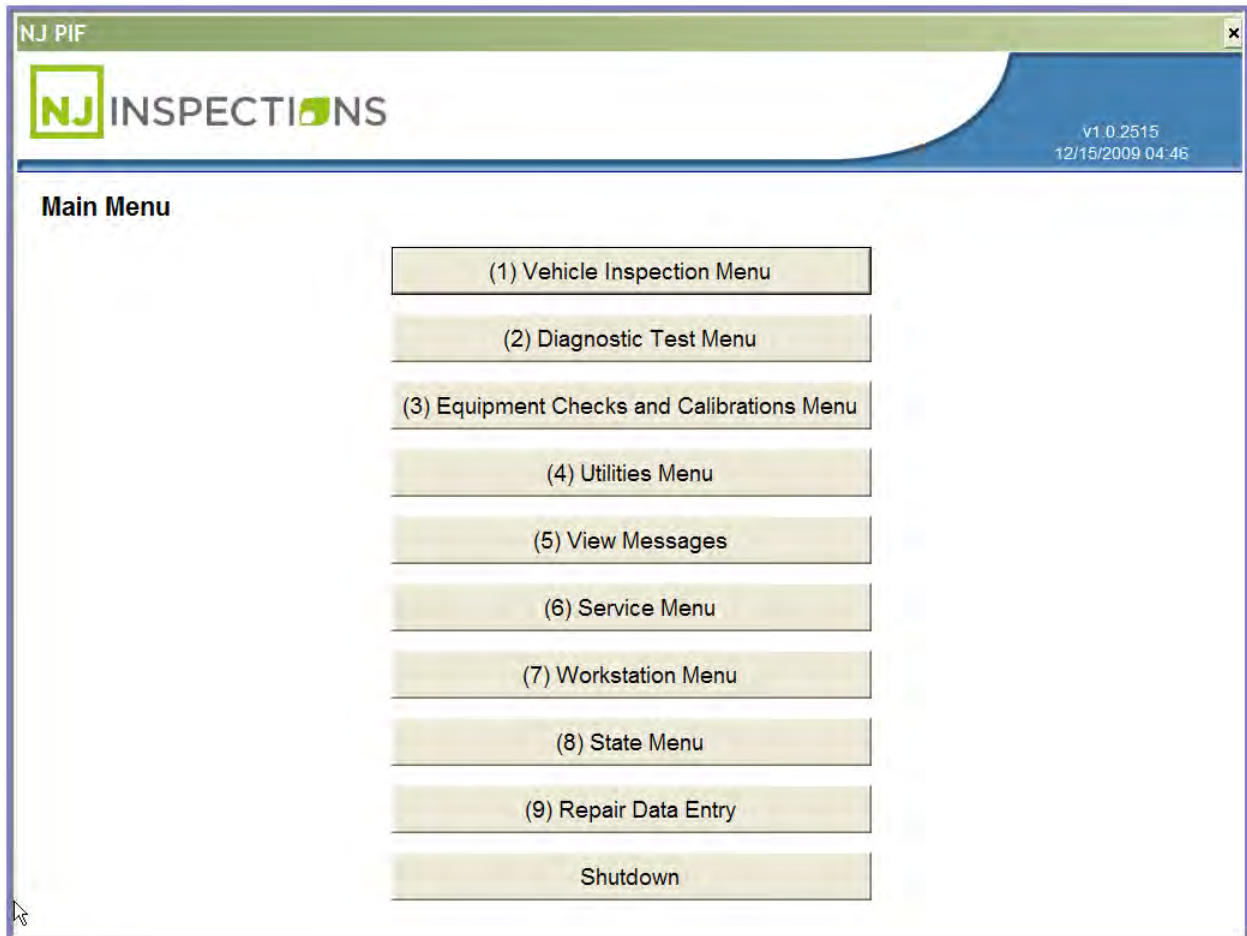

FIGURE 4-39: MAIN MENU SCREEN

NEW JERSEY OPERATORS INSTRUCTION MANUAL

REPRINT VIR (2)

(2) REPRINT VIR

STEP 1. Select (2) Reprint VIR from the (1) Vehicle Inspection Menu.

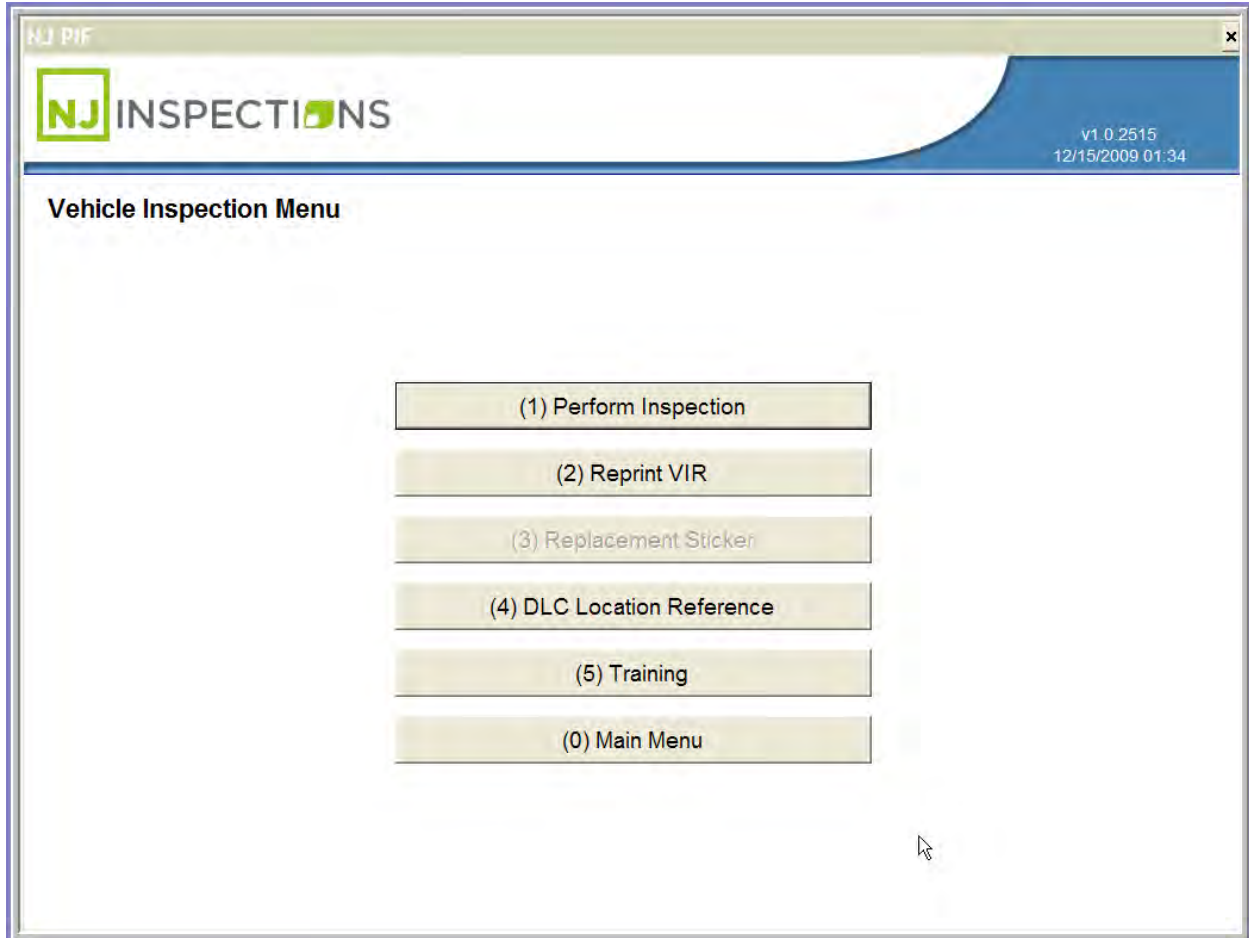

FIGURE 4-40: VEHICLE INSPECTION MENU

NEW JERSEY OPERATORS INSTRUCTION MANUAL

REPRINT VIR (2)

- STEP 2.** To **Reprint VIR** you must enter into the VIN the VIR reference number.
Select **<Done>** when complete.

NJ INSPECTIONS v1.0.2515
12/18/2009 04:53

Reprint VIR

STATE OF NEW JERSEY
MOTOR VEHICLE COMMISSION

Inspections

Vehicle Inspection Report (VIR) Printing

Motorists can print out the most recent VIR from this web site for their reference.
Note: If motorists are returning to either Centralized Inspection Facility (CIF), or Private Inspection Facility (PIF) for re-inspection or planning to repair the vehicle emissions at an Emission Repair Facility (ERF), they must bring in their VIR for the failed emission inspection(s) or emission repair.

VIN:

7J0WIK
Enter the characters you see above

Characters:

Done

FIGURE 4-41: REPRINT VIR WEBSITE

NEW JERSEY OPERATORS INSTRUCTION MANUAL

TRAINING (1)

(4) DLC LOCATION REFERENCE

STEP 1. Select (4) DLC Location Reference from the (1) Vehicle Inspection Menu.

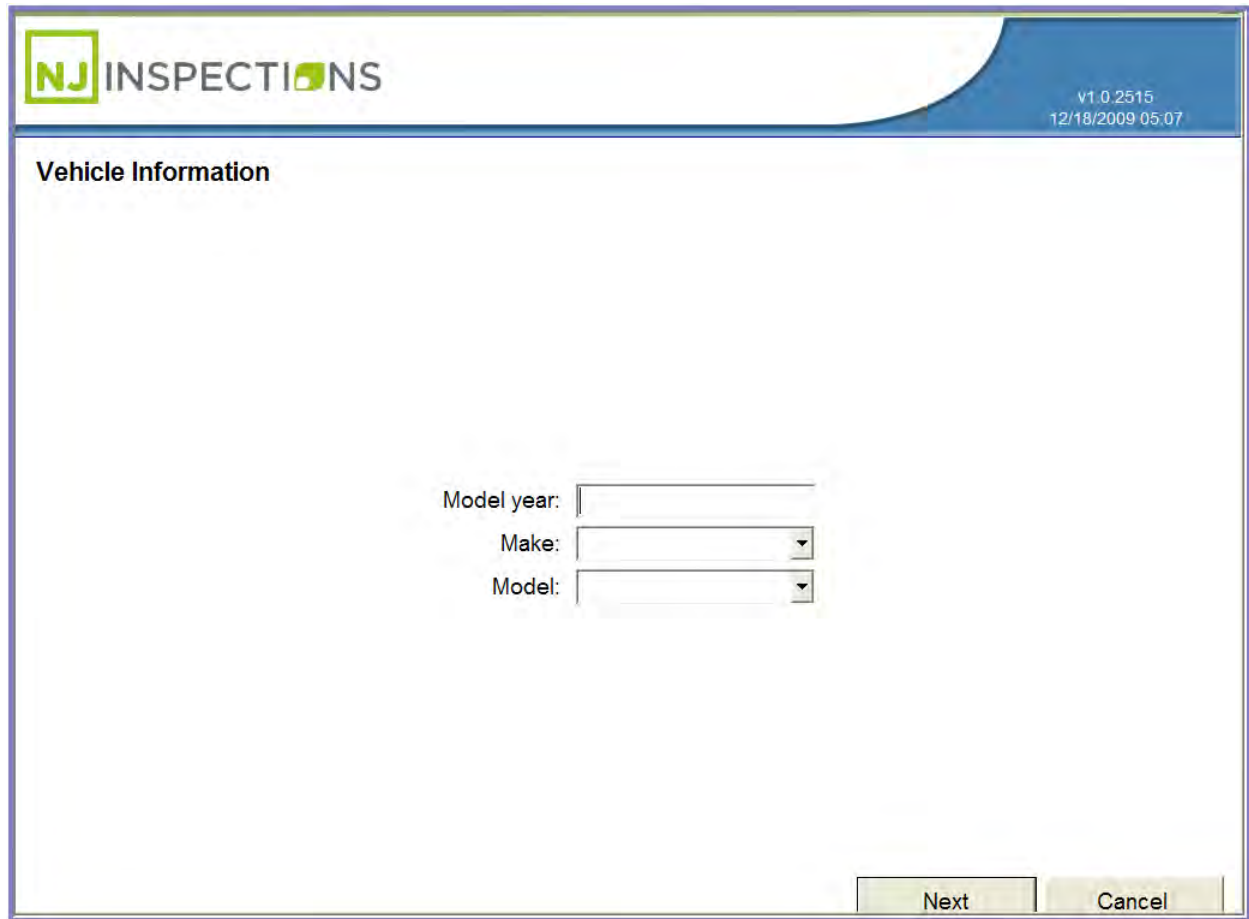

FIGURE 4-42: VEHICLE INSPECTION MENU

NEW JERSEY OPERATORS INSTRUCTION MANUAL

TRAINING (1)

STEP 2. DLC Location Vehicle Information Menu, Enter Model year, Make and Model, Select <Next> to see illustration of the DLC location for your vehicle.



The screenshot shows a web application interface for "NJ INSPECTIONS". The header includes the logo and version information: "v1.0.2515" and "12/18/2009 05:07". The main content area is titled "Vehicle Information" and contains three input fields: "Model year:" (a text box), "Make:" (a dropdown menu), and "Model:" (a dropdown menu). At the bottom right, there are two buttons: "Next" and "Cancel".

FIGURE 4-43: DLC VEHICLE INFORMATION ENTRY MENU

NEW JERSEY OPERATORS INSTRUCTION MANUAL

TRAINING (1)

STEP 3. **DLC Location Reference Map** of the location where the DLC is located for this example vehicle. **Note highlighted area, #1** indicating the location.

STEP 4. Select **OK** to return to the **Vehicle Inspection Menu**.

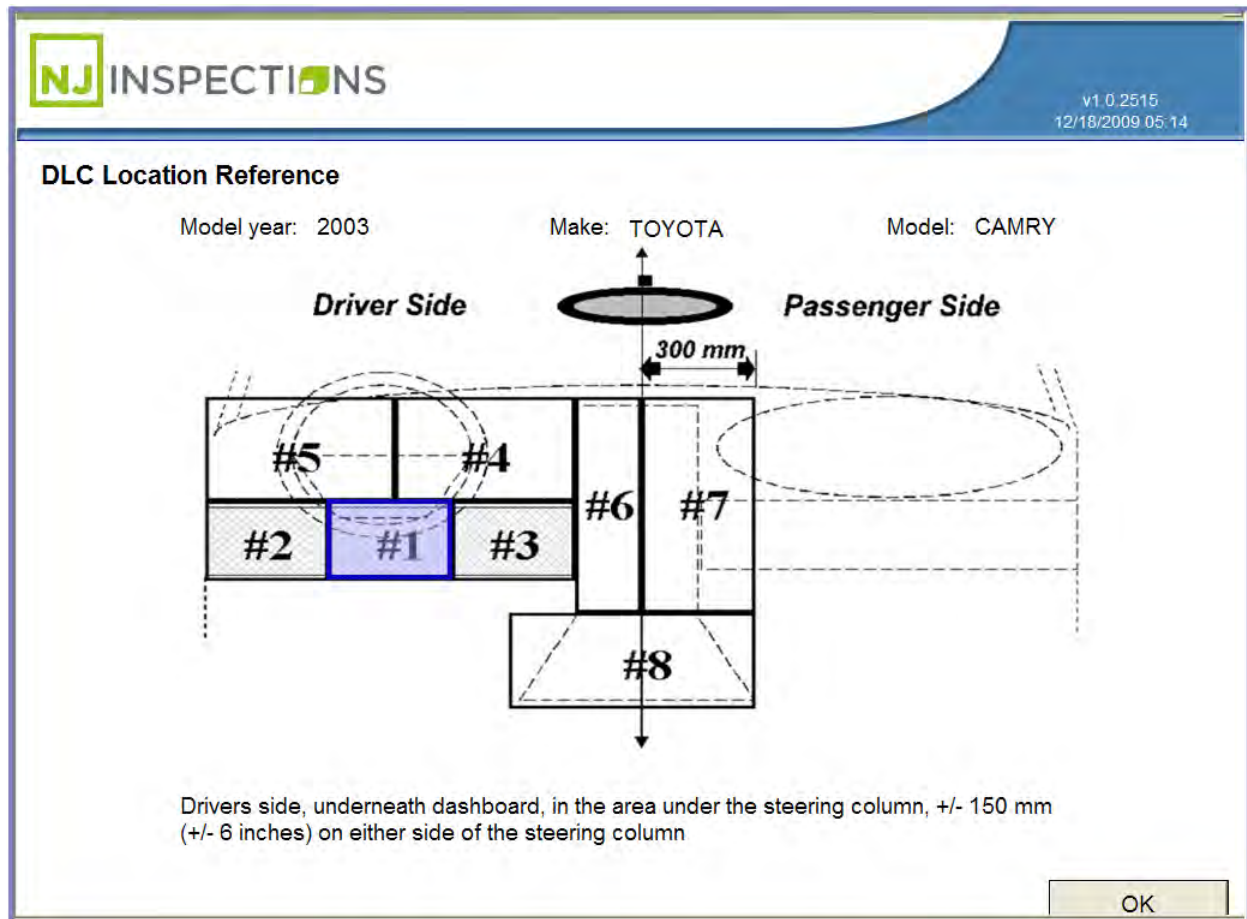

FIGURE 4-44: DLC LOCATION MAP

Chapter 5

The Diagnostics Menu (2)

NEW JERSEY OPERATORS INSTRUCTION MANUAL

THE DIAGNOSTIC TEST MENU (2)

CHAPTER 5: THE DIAGNOSTIC MENU (2)

The **NJ2009 Workstation** automatically opens the **Main Menu** when the workstation is powered on. It will take a couple minutes for the software to load.

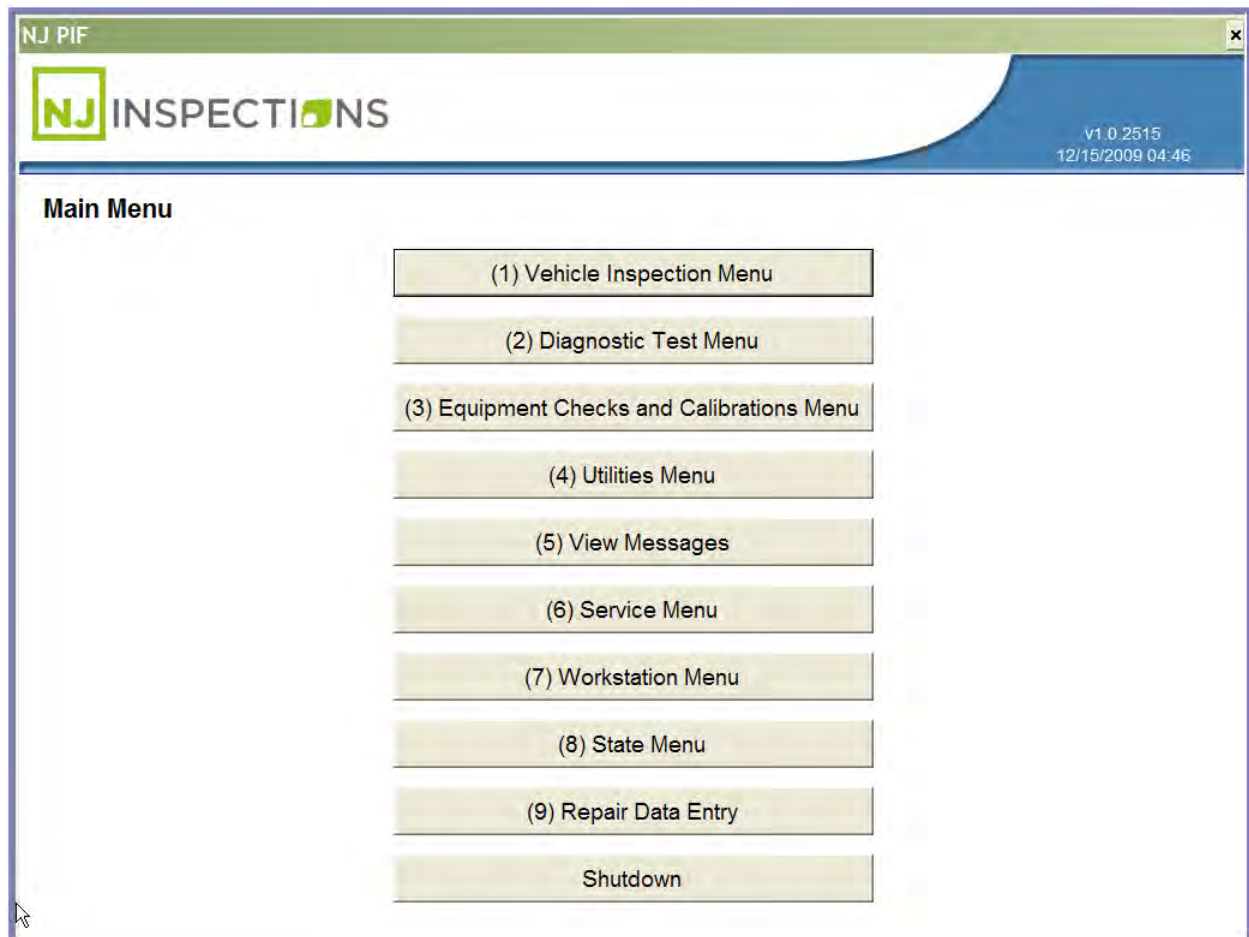

FIGURE 5-1: MAIN MENU SCREEN

NEW JERSEY OPERATORS INSTRUCTION MANUAL

THE DIAGNOSTIC TEST MENU (2)

DIAGNOSTIC TEST MENU (2)

From the **Main Menu** Select **(2) Diagnostic Test Menu**.

(1) OBDII SCAN

STEP 1. Select **(1) OBDII Scan**

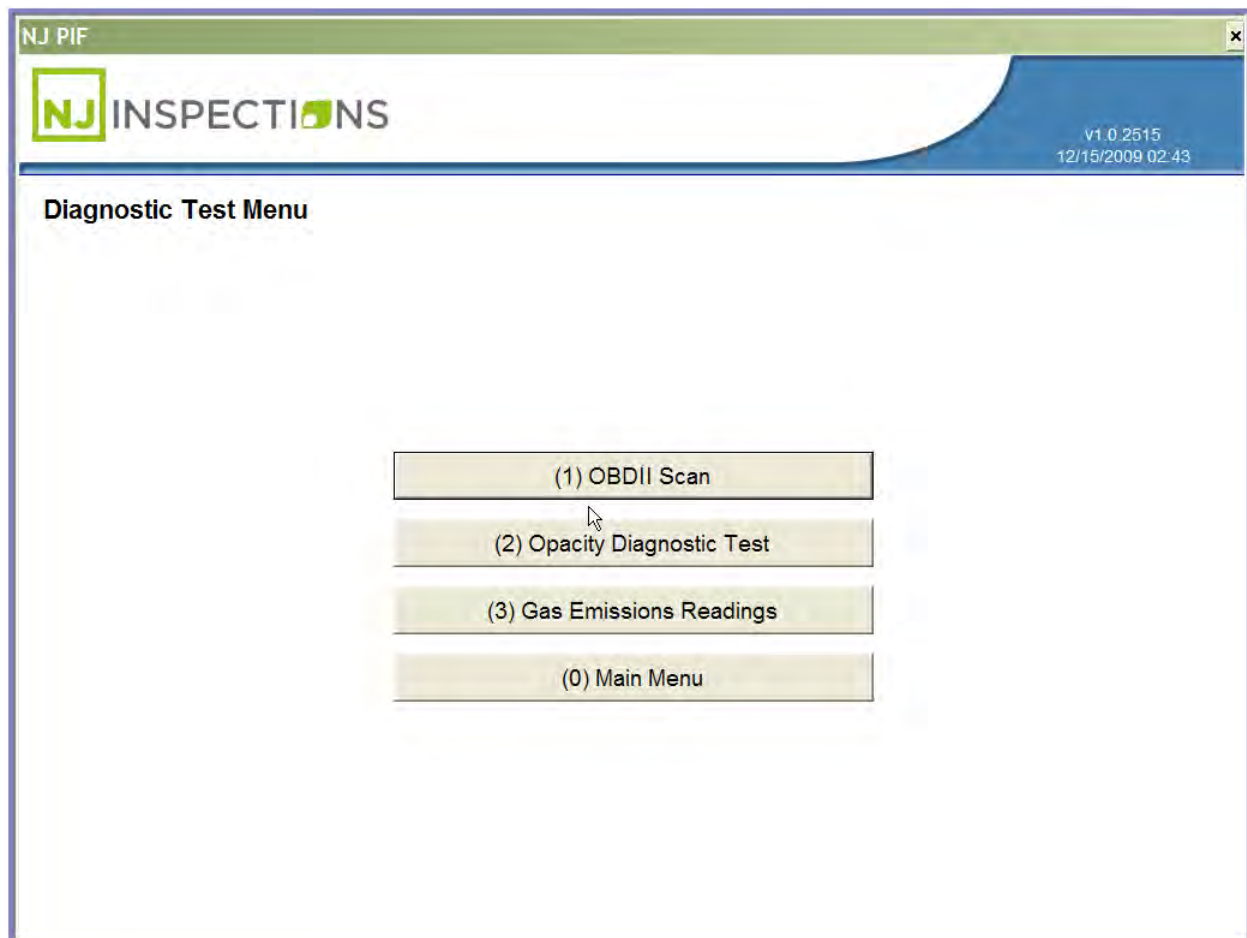

FIGURE 5-2: DIAGNOSTIC TEST MENU SCREEN

NEW JERSEY OPERATORS INSTRUCTION MANUAL

THE DIAGNOSTIC TEST MENU (2)

STEP 2. Next, “Enter vehicle Information”.

STEP 3. **Locate** the vehicles OBDII. Diagnostic Link Connector (DLC) and attach the workstation OBDII Cable.

STEP 4. **Select next** to continue.

Note: If you do not want to continue with the OBDII Diagnostic Test select cancel.

NJ PIF

NJ INSPECTIONS

v1.1.2564
12/16/2009 04:23

Enter Vehicle Info
OBDII Scan

This is not an official test. Results of this diagnostic test may not be indicative of the actual inspection results. The results of this test should be used for diagnostic purposes only.

License Plate:

Model year:

Make:

Model:

Next Cancel

FIGURE 5-3: START OBDII SCAN SCREEN

**NEW JERSEY
OPERATORS INSTRUCTION MANUAL**

THE DIAGNOSTIC TEST MENU (2)

STEP 5. Next, **Connect to DLC Screen**, follow steps 1-3 or Press <F1> for help locating the vehicles DLC.

STEP 6. Could the DLC be located and a connection made? Select **Yes** or **No**.

STEP 7. If **Yes**, continue to next step.

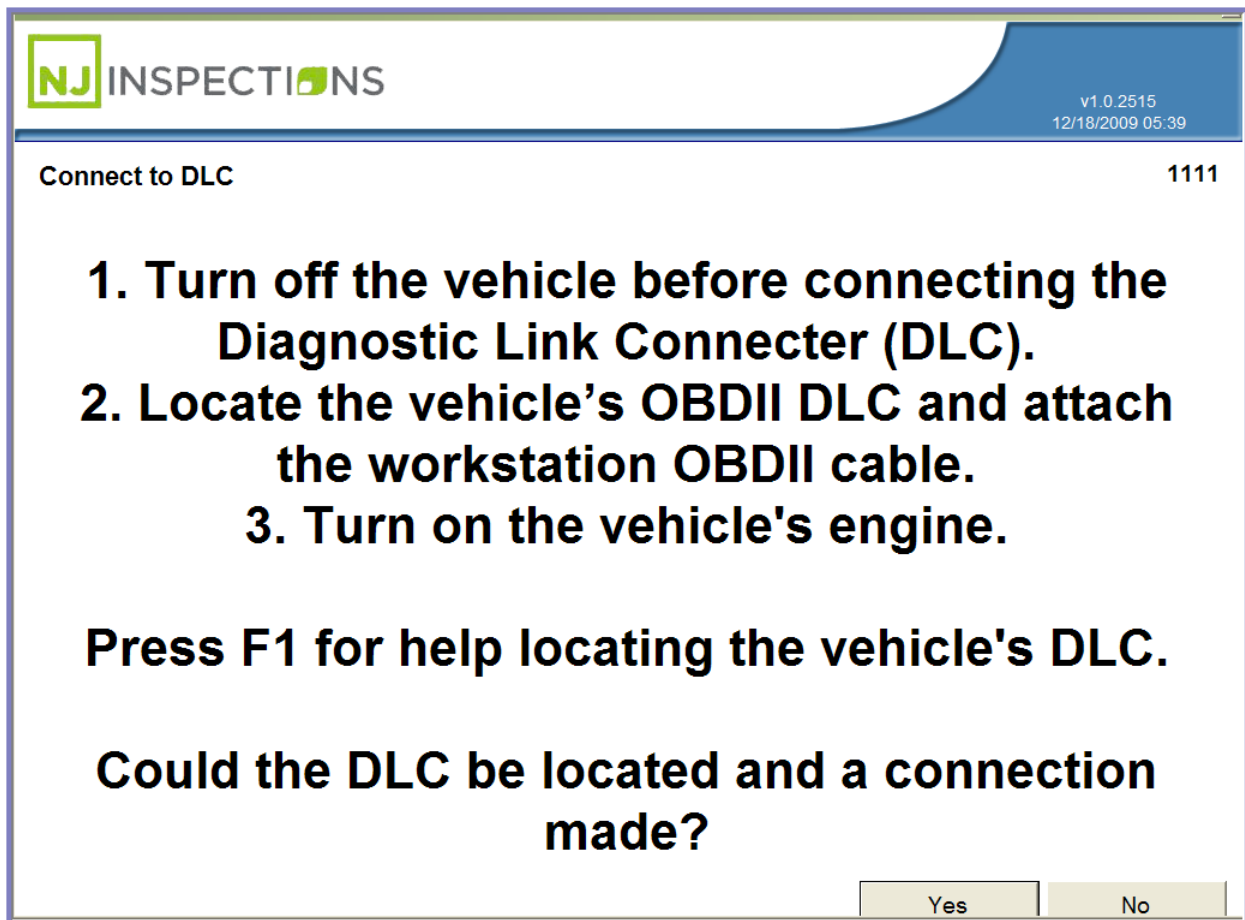

FIGURE 5-4: CONNECT TO DLC SCREEN

NEW JERSEY OPERATORS INSTRUCTION MANUAL

THE DIAGNOSTIC TEST MENU (2)

- STEP 8.** Next, **OBDII Scan in Progress** message appears, now **Verify your connection to the OBDII module.**
- STEP 9.** Then **select** appropriate OBD reading.
- STEP 10.** If reading is Pass, **select <Pass>** to continue with OBDII Diagnostic Test.

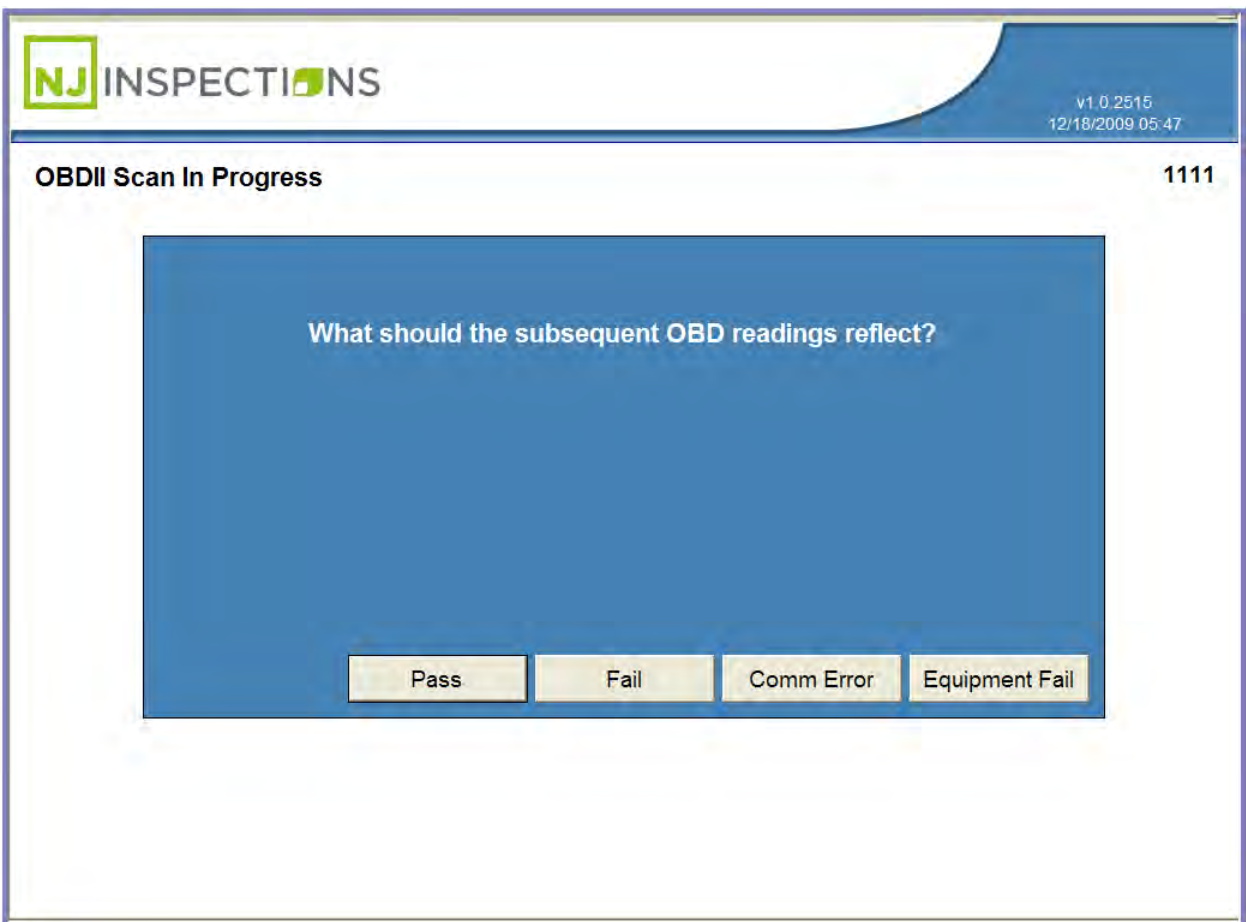

FIGURE 5-5: OBDII SCAN IN PROGRESS SCREEN

NEW JERSEY OPERATORS INSTRUCTION MANUAL

THE DIAGNOSTIC TEST MENU (2)

STEP 11. View/Print OBDII Scan Results

STEP 12. Select <OK> to return to the **Diagnostic Test Menu** or <Print> for print copy of results.

NJ INSPECTIONS v1.0.2515
12/18/2009 05:51

Manual OBDII Scan Results 1111

This is not an official test. Results of this diagnostic test may not be indicative of the actual inspection results. The results of this test should be used for diagnostic purposes only.

OBDII firmware version: 1

Readiness Monitors	Make: ACURA	DTCs:
Misfire: Ready	Model: CL	
Fuel control: Ready	Model Year: 2003	
Comp. components: Ready	VIN: 1G1JC1243X7281142	
Catalyst: Ready	CAL ID: ZYXWVUTSRQPONMLK	
Heated catalyst: Ready	CVN: 43414C49	
EVAP: Ready	Distance MIL On: 0	
Secondary air injection: Ready	No. of warmups: -1	
AC: Ready	Miles since DTC cleared: 0	
O2 sensor: Ready	Time MIL On: -1	
O2 sensor heater: Ready	Minutes since DTC cleared: -1	
EGR: Ready	MIL command status: Off	
	RPM: 700	

OK Print

FIGURE 5-6: OBDII SCAN RESULTS

NEW JERSEY OPERATORS INSTRUCTION MANUAL

OPACITY DIAGNOSTIC TEST (2)

(2) OPACITY DIAGNOSTIC TEST

Note: Screen displays for diagnostic check may vary from screens used for actual inspection.

STEP 1. From the **Diagnostic Test Menu**, Select **(2) Opacity Diagnostic Test**.

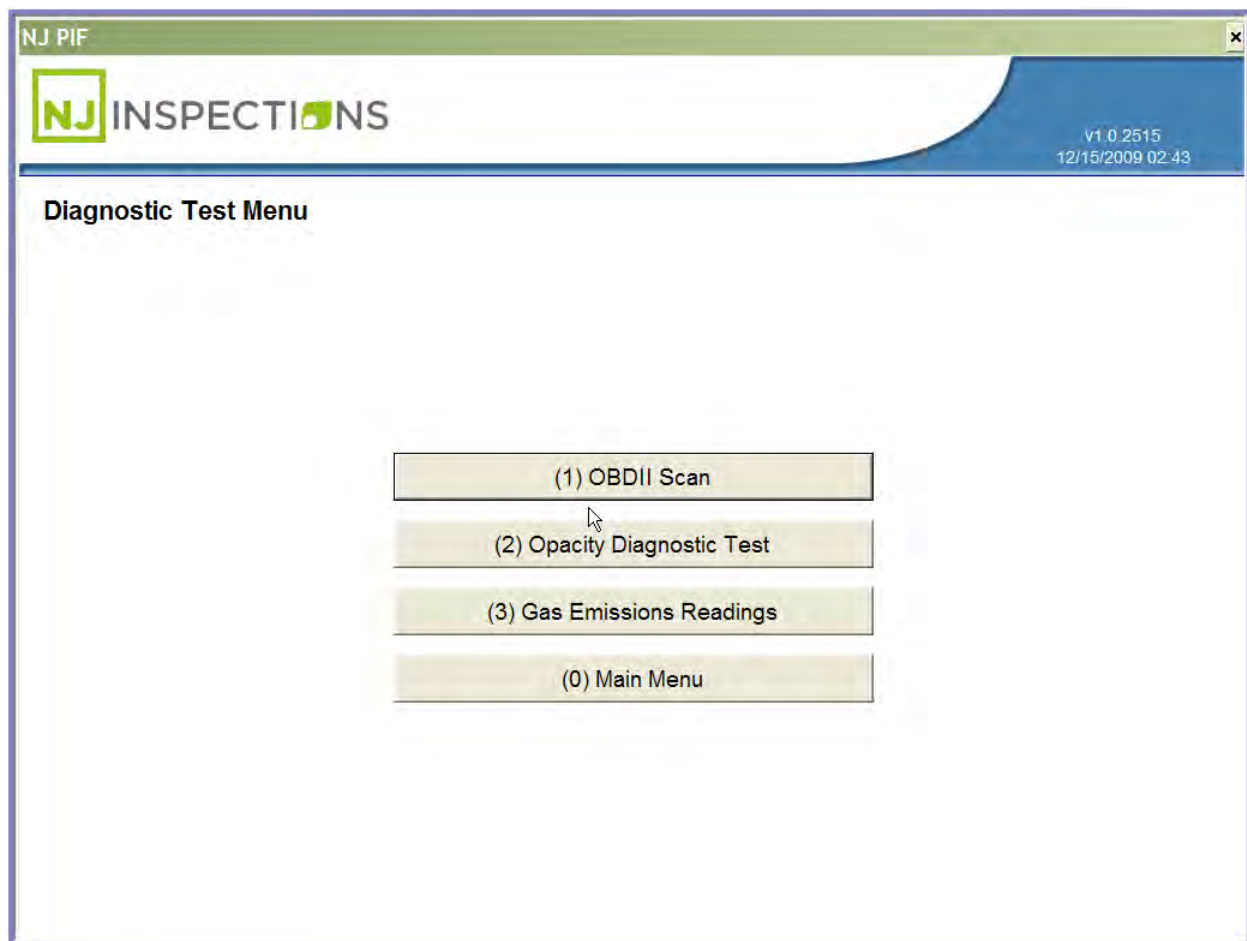

FIGURE 5-7: DIAGNOSTIC TEST MENU

NEW JERSEY OPERATORS INSTRUCTION MANUAL

OPACITY DIAGNOSTIC TEST (2)

STEP 2. Start Opacity Diagnostic Test, enter requested information in each field and **Select Next**.

Please note: Message below is only showed on manual Opacity test.

“This is not an official test. Results of this diagnostic test may not be indicative of the actual inspection results. The results of this test should be used for diagnostic purposes only”.

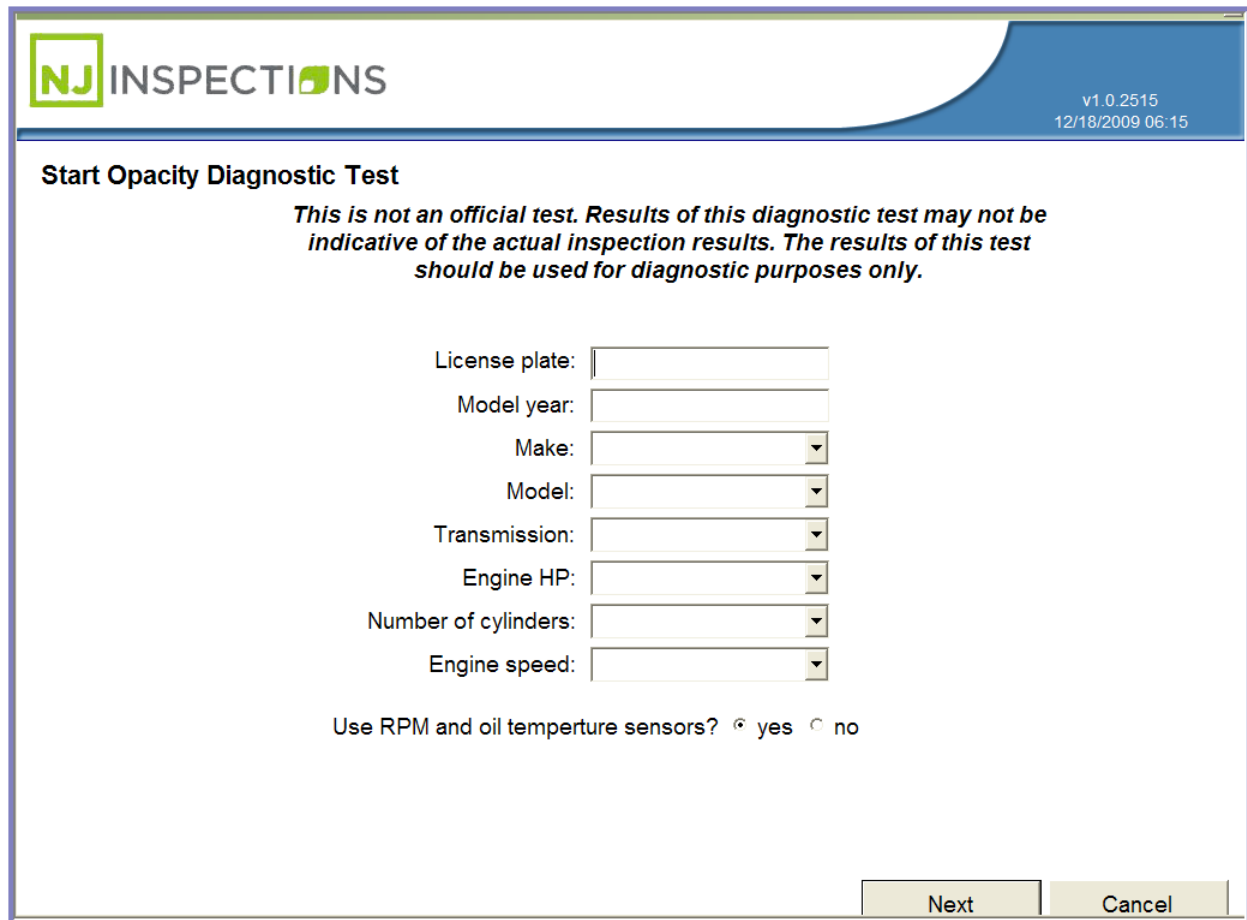

The screenshot shows a web-based form titled "Start Opacity Diagnostic Test". At the top left is the "NJ INSPECTIONS" logo. At the top right, it displays "v1.0.2515" and "12/18/2009 06:15". Below the title, a warning message is displayed: "This is not an official test. Results of this diagnostic test may not be indicative of the actual inspection results. The results of this test should be used for diagnostic purposes only." The form contains several input fields: "License plate:" (text box), "Model year:" (text box), "Make:" (dropdown menu), "Model:" (dropdown menu), "Transmission:" (dropdown menu), "Engine HP:" (dropdown menu), "Number of cylinders:" (dropdown menu), and "Engine speed:" (dropdown menu). Below these fields is a question: "Use RPM and oil temperture sensors?" with radio buttons for "yes" (selected) and "no". At the bottom right, there are two buttons: "Next" and "Cancel".

FIGURE 5-8: START OPACITY DIAGNOSTIC TEST

NEW JERSEY OPERATORS INSTRUCTION MANUAL

OPACITY DIAGNOSTIC TEST (2)

STEP 3. Turn Off Accessories (Diesel Opacity Test)

STEP 4. Turn off the engine brake and all vehicle accessories, including, but not limited to, air conditioning, heating, defroster, radio, and lights.

STEP 5. Select <Next> to continue.

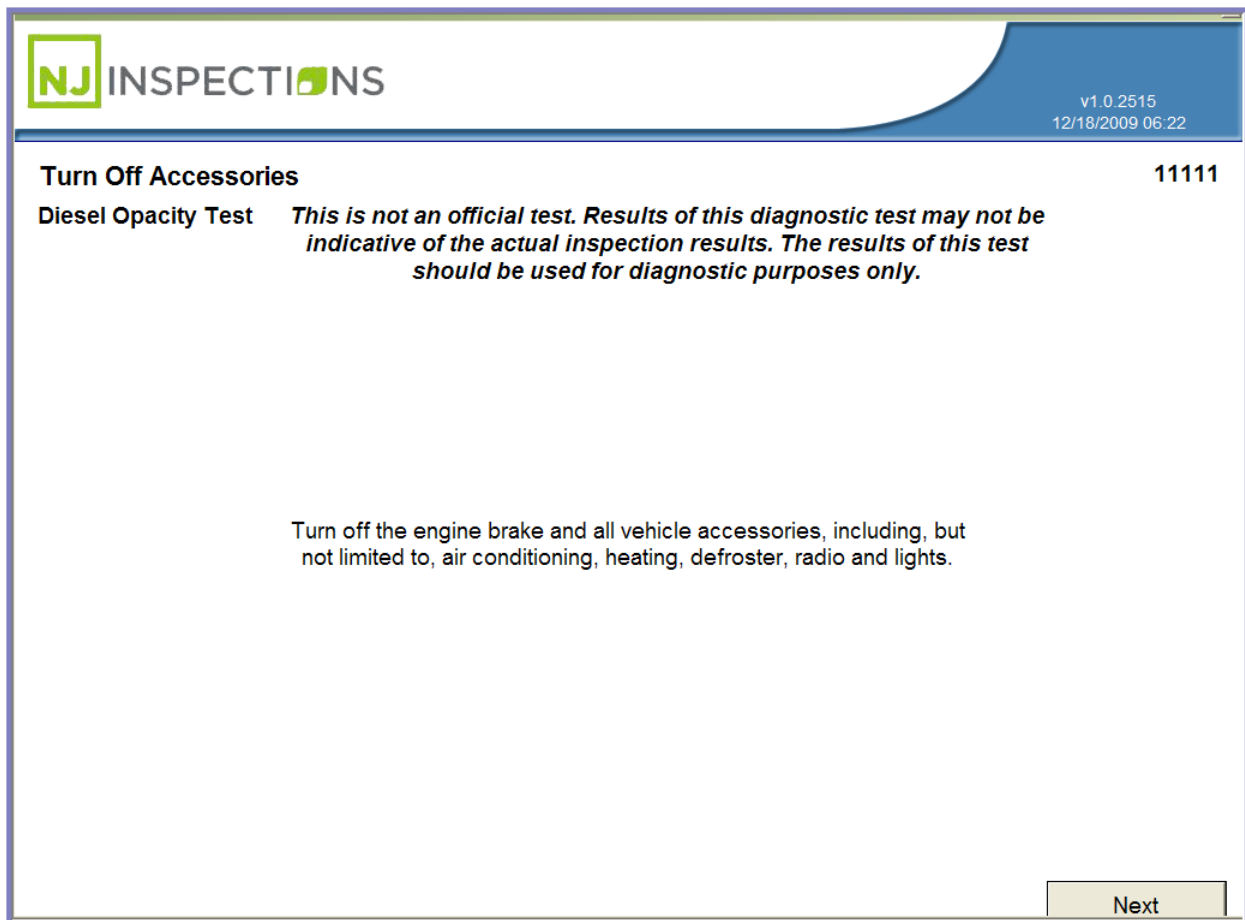

FIGURE 5-9: TURN OFF ACCESSORIES DIESEL OPACITY TEST SCREEN

NEW JERSEY OPERATORS INSTRUCTION MANUAL

OPACITY DIAGNOSTIC TEST (2)

STEP 6. Test Selection (Diesel Opacity Test) - Select Test to be performed.

- (1) Rolling Acceleration
- (2) Power Brake
- (3) Snap Acceleration

(1) Rolling Acceleration:

STEP 1. Select (1) Rolling Acceleration

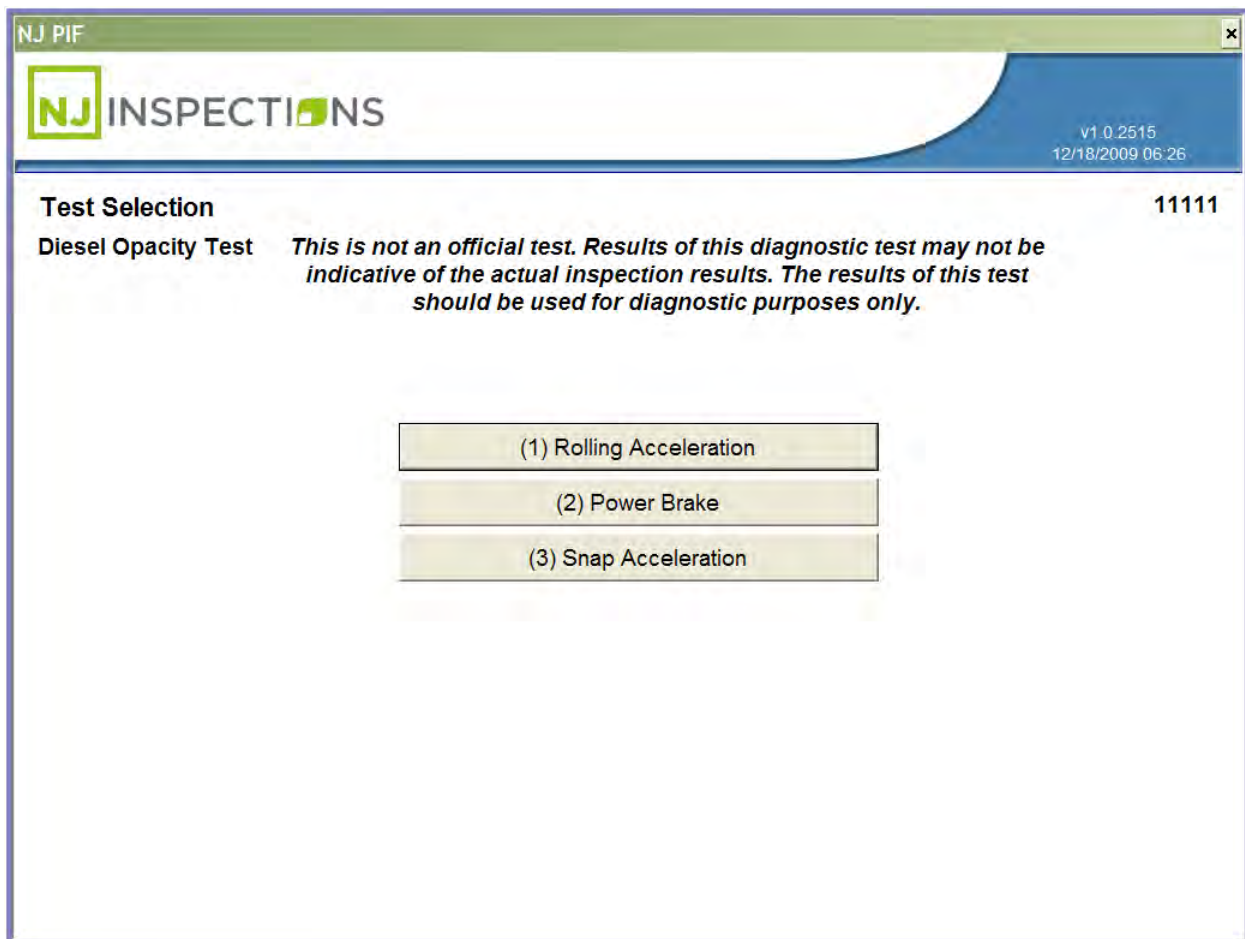

FIGURE 5-10: TEST SELECTION (DIESEL OPACITY TEST)

NEW JERSEY OPERATORS INSTRUCTION MANUAL

OPACITY DIAGNOSTIC TEST (2)

STEP 2. Connect Smokemeter (Diesel Opacity Test)

STEP 3. Follow instructions on screen, **Click <Next>** to continue.

NJ INSPECTIONS v1.0.2515
12/18/2009 06:31

Connect Smokemeter 11111

Diesel Opacity Test *This is not an official test. Results of this diagnostic test may not be indicative of the actual inspection results. The results of this test should be used for diagnostic purposes only.*

- **Affix the RPM sensor to the engine and vehicle according to the smokemeter manufacturer's instructions**
- **Insert the engine oil temperature sensor into the oil dipstick tube and into the crankcase oil according to the smokemeter manufacturer's instructions**
- **Connect the engine RPM and oil temperature sensors to the smokemeter according to the smokemeter manufacturer's instructions**
- **Affix the smokemeter according to the manufacturer's instructions to the end of the vehicle's exhaust pipe.**

Next

FIGURE 5-11: CONNECT SMOKEMETER (DIESEL OPACITY TEST)

NEW JERSEY OPERATORS INSTRUCTION MANUAL

OPACITY DIAGNOSTIC TEST (2)

STEP 4. Next, Start Rolling Acceleration Test

- Select what the result of the smokemeter test should be.

STEP 5. Smokemeter Pass - Select Pass to continue to the next step.

The screenshot shows a software window titled "NJ INSPECTIONS" with a version number "v1.0.2515" and date "12/21/2009 10:55". The main content area is titled "Start Rolling Acceleration Test" with a user ID "12345". Below the title, it says "Diesel Opacity Test" followed by a warning: "This is not an official test. Results of this diagnostic test may not be". A large blue dialog box is centered on the screen with the text "What should the result of the smokemeter test be?". At the bottom of this dialog box are five buttons: "Pass", "Fail", "Invalid", "Cancelled", and "Comm Error". In the bottom right corner of the main window, there is an "Abort" button.

FIGURE 5-12: START ROLLING ACCELERATION TEST (DIESEL OPACITY TEST)

NEW JERSEY OPERATORS INSTRUCTION MANUAL

OPACITY DIAGNOSTIC TEST (2)

STEP 6. View/Print Opacity Diagnostic Test Results (Start Rolling Acceleration)

STEP 7. Select <OK> to return to the Diagnostic Test Menu or <Print> for print copy of results.

NJ INSPECTIONS v1.0.2515
12/21/2009 11:05

Opacity Diagnostic Test Results 12345

This is not an official test. Results of this diagnostic test may not be indicative of the actual inspection results. The results of this test should be used for diagnostic purposes only.

Make: ACURA	Ambient temperature: 35.5
Model: CSX	Barometric pressure: 0
Model Year: 2009	Relative humidity: 0
	Dewpoint: 0

Snap 1	Snap 2	Snap 3	
Opacity: 0	Opacity: 0	Opacity: 29.8	Opacity average: 29.8
Oil temp: 0	Oil temp: 0	Oil temp: 140	Opacity spread: 5
Max RPM: 0	Max RPM: 0	Max RPM: 0	Zero drift: 1.2
Min RPM: 0	Min RPM: 0	Min RPM: 0	
Rise time: 0	Rise time: 0	Rise time: 4	

OK Print

FIGURE 5-13: OPACITY DIAGNOSTIC TEST RESULTS

NEW JERSEY OPERATORS INSTRUCTION MANUAL

OPACITY DIAGNOSTIC TEST (2)

(2) Power Brake Test

STEP 1. Follow steps 1-6 above from the **Diagnostic Test Menu** (See Figure 5-5 thru Figure 5-9) and **Select (2) Power Brake**

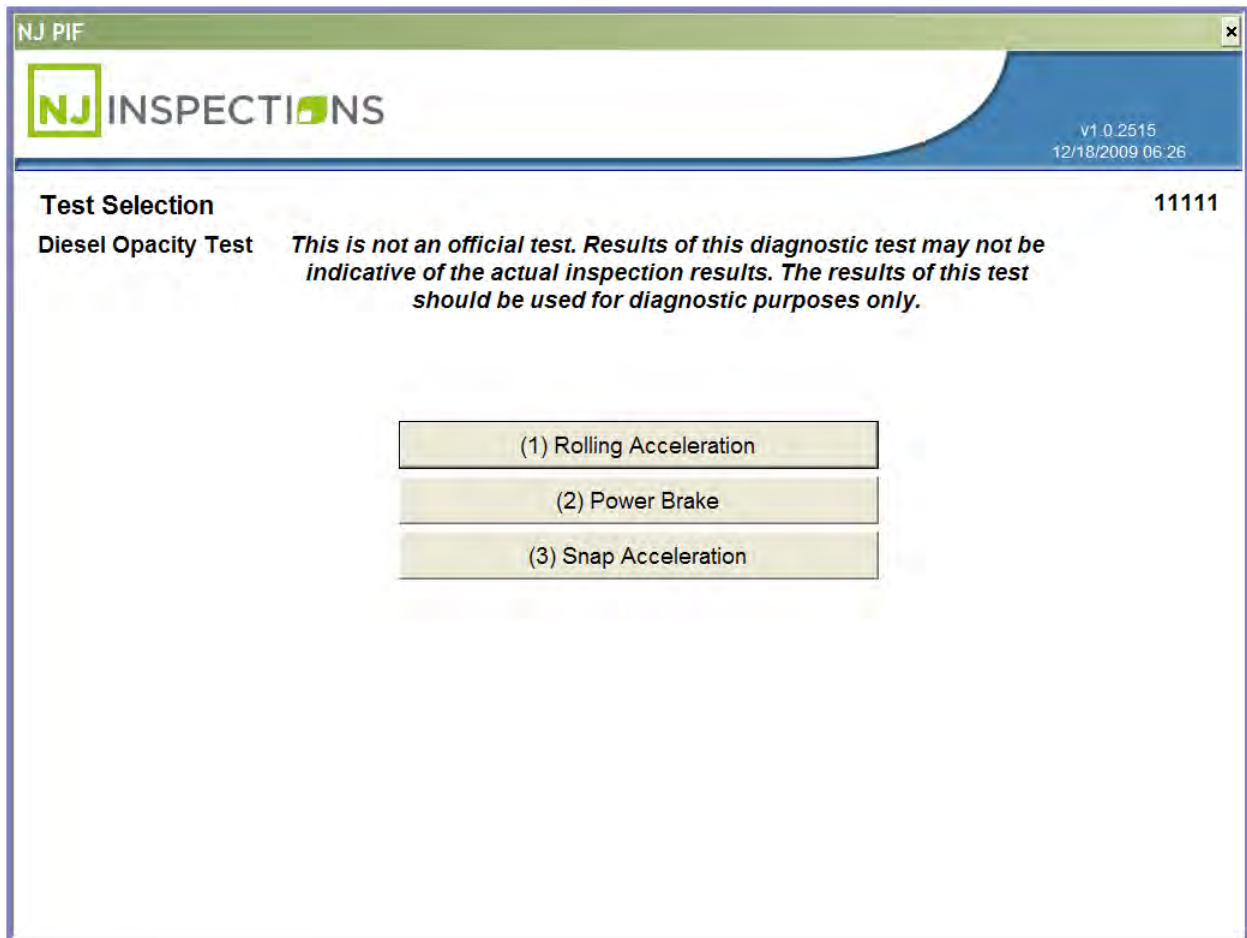

FIGURE 5-14: TEST SELECTION (DIESEL OPACITY TEST)

NEW JERSEY OPERATORS INSTRUCTION MANUAL

OPACITY DIAGNOSTIC TEST (2)

STEP 2. Connect Smokemeter (Diesel Opacity Test)

STEP 3. Follow instructions on screen, **Click <Next>** to continue.

NJ INSPECTIONS v1.0.2515
12/18/2009 06:31

Connect Smokemeter 11111

Diesel Opacity Test *This is not an official test. Results of this diagnostic test may not be indicative of the actual inspection results. The results of this test should be used for diagnostic purposes only.*

- **Affix the RPM sensor to the engine and vehicle according to the smokemeter manufacturer's instructions**
- **Insert the engine oil temperature sensor into the oil dipstick tube and into the crankcase oil according to the smokemeter manufacturer's instructions**
- **Connect the engine RPM and oil temperature sensors to the smokemeter according to the smokemeter manufacturer's instructions**
- **Affix the smokemeter according to the manufacturer's instructions to the end of the vehicle's exhaust pipe.**

Next

FIGURE 5-15: CONNECT SMOKEMETER (DIESEL OPACITY TEST)

NEW JERSEY OPERATORS INSTRUCTION MANUAL

OPACITY DIAGNOSTIC TEST (2)

STEP 4. Start Power Brake Test

- Select what the result of the smokemeter test should be.

STEP 5. Smokemeter Pass - Select Pass to continue to the next step.

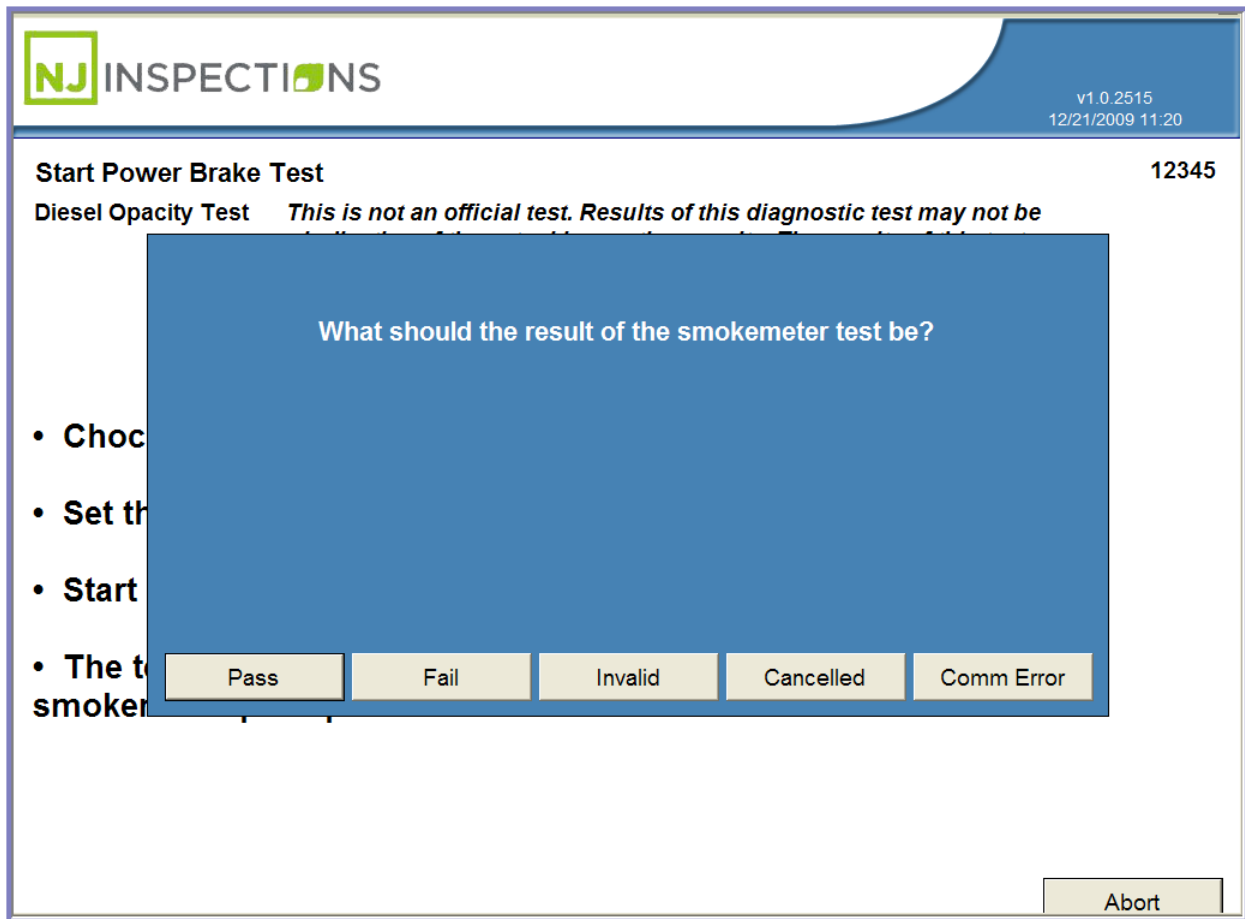

FIGURE 5-16: START POWER BRAKE TEST (DIESEL OPACITY TEST)

NEW JERSEY OPERATORS INSTRUCTION MANUAL

OPACITY DIAGNOSTIC TEST (2)

STEP 6. View/Print Opacity Diagnostic Test Results (Power Break Test)

STEP 7. Select **<OK>** to return to the **Diagnostic Test Menu** or **<Print>** for print copy of results.

NJ INSPECTIONS v1.0.2515
12/21/2009 11:24

Opacity Diagnostic Test Results 12345

This is not an official test. Results of this diagnostic test may not be indicative of the actual inspection results. The results of this test should be used for diagnostic purposes only.

Make: BUICK	Ambient temperature: 35.5
Model: ALLURE	Barometric pressure: 0
Model Year: 2009	Relative humidity: 0
	Dewpoint: 0

Snap 1	Snap 2	Snap 3	
Opacity: 29.8	Opacity: 29.8	Opacity: 29.8	Opacity average: 29.8
Oil temp: 140	Oil temp: 140	Oil temp: 140	Opacity spread: 5
Max RPM: 0	Max RPM: 0	Max RPM: 0	Zero drift: 1.2
Min RPM: 0	Min RPM: 0	Min RPM: 0	
Rise time: 4	Rise time: 4	Rise time: 4	

OK Print

FIGURE 5-17: OPACITY DIAGNOSTIC TEST RESULTS (POWER BREAK TEST)

NEW JERSEY OPERATORS INSTRUCTION MANUAL

OPACITY DIAGNOSTIC TEST (2)

(3) Snap Acceleration Test:

STEP 1. Follow steps 1-6 above from the **Diagnostic Test Menu** (See Figure 5-5 thru Figure 5-9) and **Select (3) Snap Acceleration**

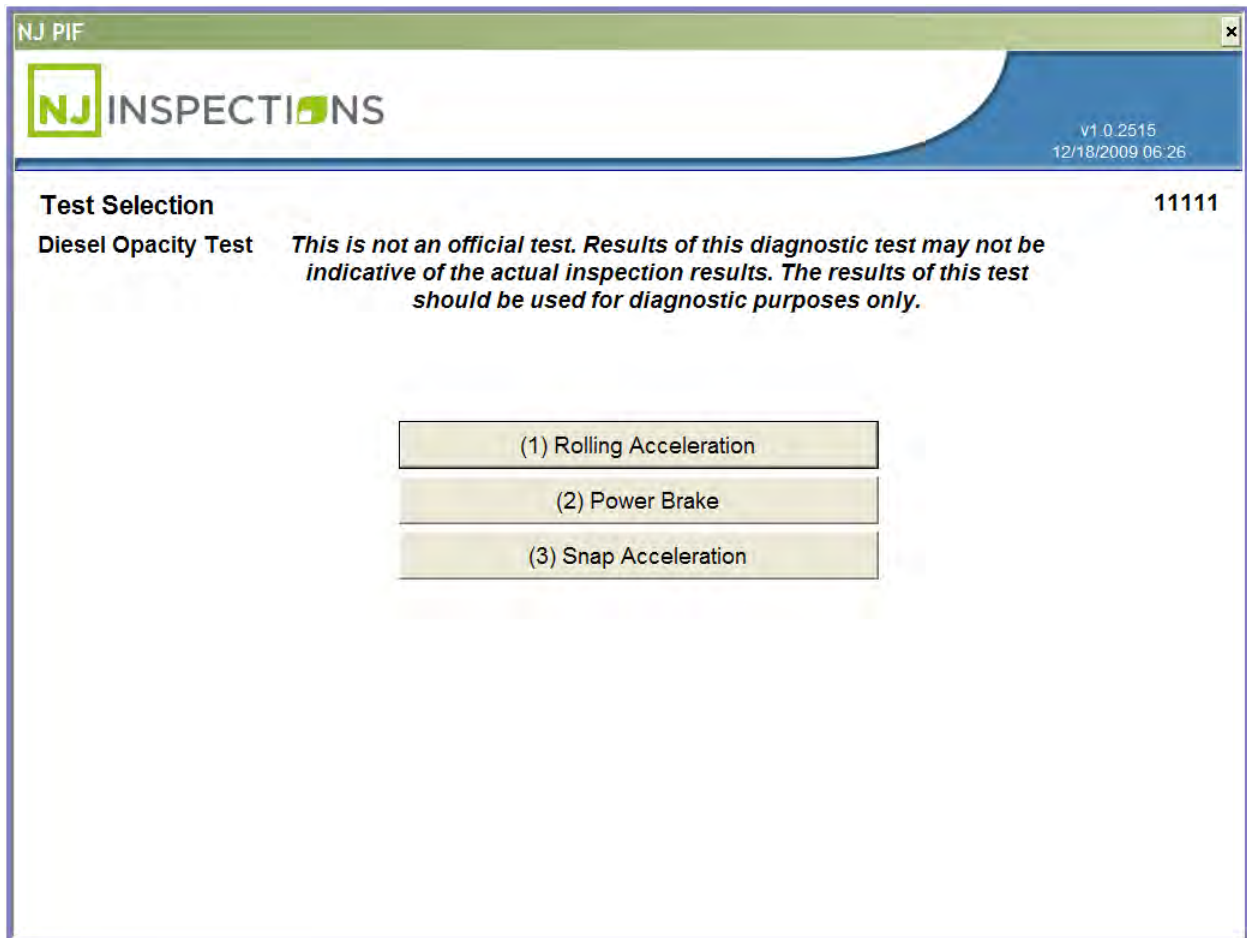

FIGURE 5-18: TEST SELECTION (DIESEL OPACITY TEST)

NEW JERSEY OPERATORS INSTRUCTION MANUAL

OPACITY DIAGNOSTIC TEST (2)

STEP 2. Start Snap Acceleration Test

- Select what the result of the smokemeter test should be.

STEP 3. Smokemeter Pass - Select Pass to continue to the next step.

NJ INSPECTIONS v1.0.2515
12/21/2009 11:53

Start Snap Acceleration Test 12345

Diesel Opacity Test *This is not an official test. Results of this diagnostic test may not be*

What should the result of the smokemeter test be?

- Choc
- Ensue
- The t smoker

Pass Fail Invalid Cancelled Comm Error

Abort

FIGURE 5-19: START SNAP ACCELERATION TEST (DIESEL OPACITY TEST)

NEW JERSEY OPERATORS INSTRUCTION MANUAL

OPACITY DIAGNOSTIC TEST (2)

STEP 4. View/Print Opacity Diagnostic Test Results (Snap Acceleration Test)

STEP 5. Select <OK> to return to the Diagnostic Test Menu or <Print> for print copy of results.

NJ INSPECTIONS v1.0.2515
12/21/2009 11:55

Opacity Diagnostic Test Results 12345

This is not an official test. Results of this diagnostic test may not be indicative of the actual inspection results. The results of this test should be used for diagnostic purposes only.

Make: ACURA	Ambient temperature: 35.5
Model: MDX	Barometric pressure: 0
Model Year: 2009	Relative humidity: 0
	Dewpoint: 0

Snap 1	Snap 2	Snap 3	
Opacity: 29.8	Opacity: 29.8	Opacity: 29.8	Opacity average: 29.8
Oil temp: 140	Oil temp: 140	Oil temp: 140	Opacity spread: 5
Max RPM: 0	Max RPM: 0	Max RPM: 0	Zero drift: 1.2
Min RPM: 0	Min RPM: 0	Min RPM: 0	
Rise time: 4	Rise time: 4	Rise time: 4	

OK Print

FIGURE 5-20: OPACITY DIAGNOSTIC TEST RESULTS (SNAP ACCELERATION TEST)

NEW JERSEY OPERATORS INSTRUCTION MANUAL

OPACITY DIAGNOSTIC TEST (2)

(3) GAS EMISSIONS READINGS

STEP 1. From the **Diagnostic Test Menu**, Select **(3) Test Gas Emissions Readings**.

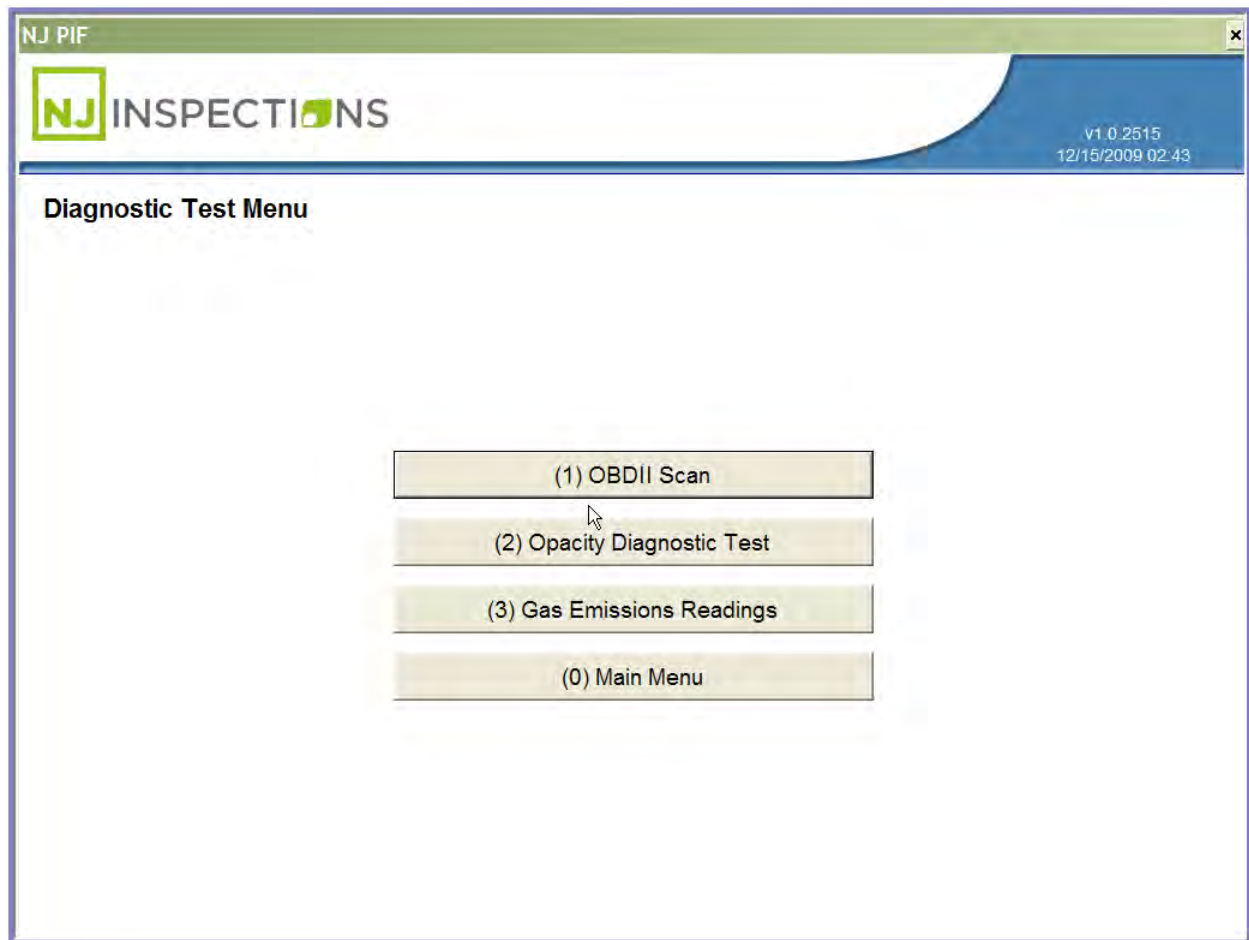

FIGURE 5-21: DIAGNOSTIC TEST MENU

NEW JERSEY OPERATORS INSTRUCTION MANUAL

OPACITY DIAGNOSTIC TEST (2)

STEP 2. Enter Vehicle Info (Gas Diagnostic Test)

STEP 3. Enter requested information and **Select <Next>** to continue.

NJ INSPECTIONS v1.0.2515
12/21/2009 01:49

Enter Vehicle Info

Gas Diagnostic Test *This is not an official test. Results of this diagnostic test may not be indicative of the actual inspection results. The results of this test should be used for diagnostic purposes only.*

License plate:

Model year:

Make:

Model:

Next Cancel

FIGURE 5-22: ENTER VEHICLE INFO (GAS DIAGNOSTIC TEST)

NEW JERSEY OPERATORS INSTRUCTION MANUAL

OPACITY DIAGNOSTIC TEST (2)

STEP 4. Gas Emission Readings Start

STEP 5. Follow instructions on the screen, **Select <Next>** to continue.

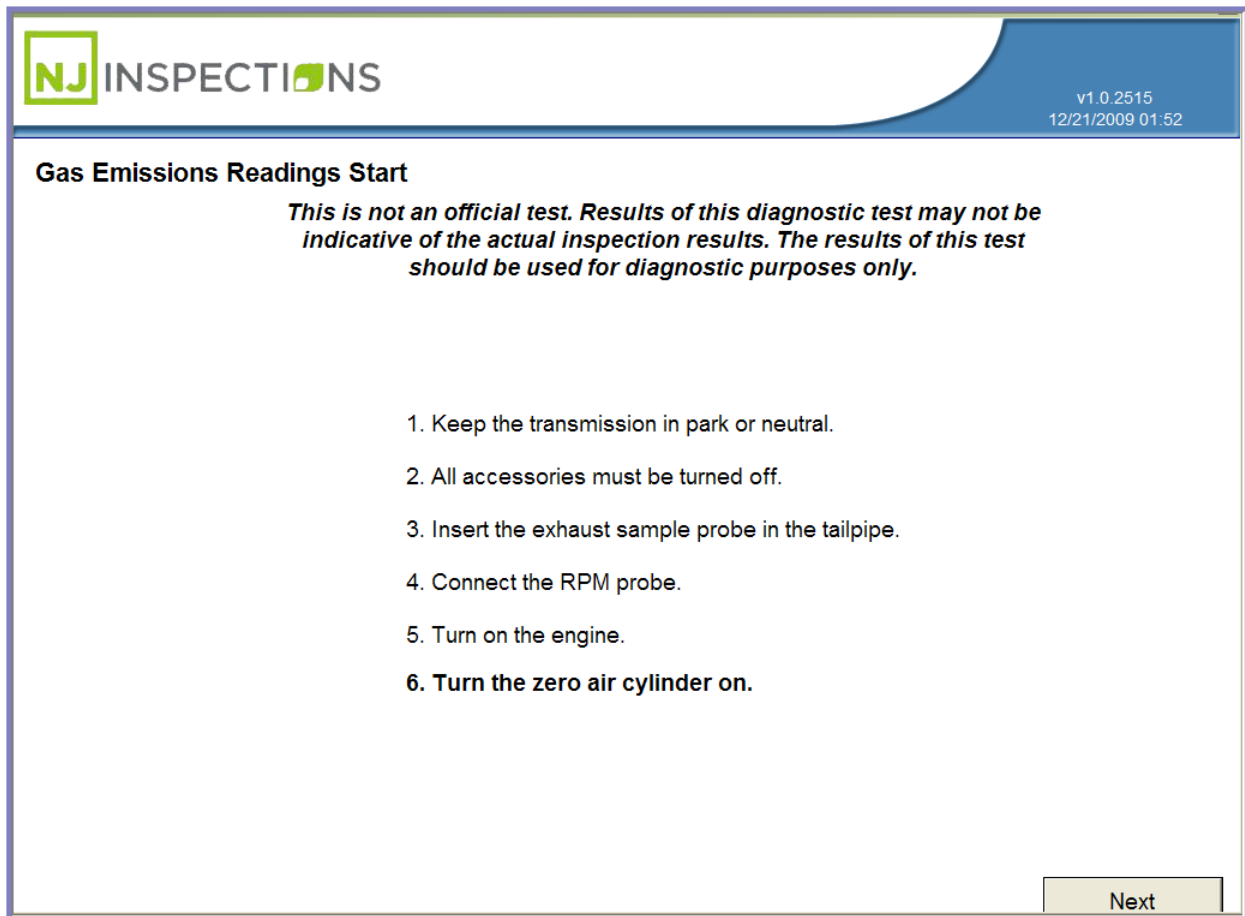

FIGURE 5-23: GAS EMISSIONS READING START

NEW JERSEY OPERATORS INSTRUCTION MANUAL

OPACITY DIAGNOSTIC TEST (2)

STEP 6. Zero Calibration Message (Gas Diagnostic Test)

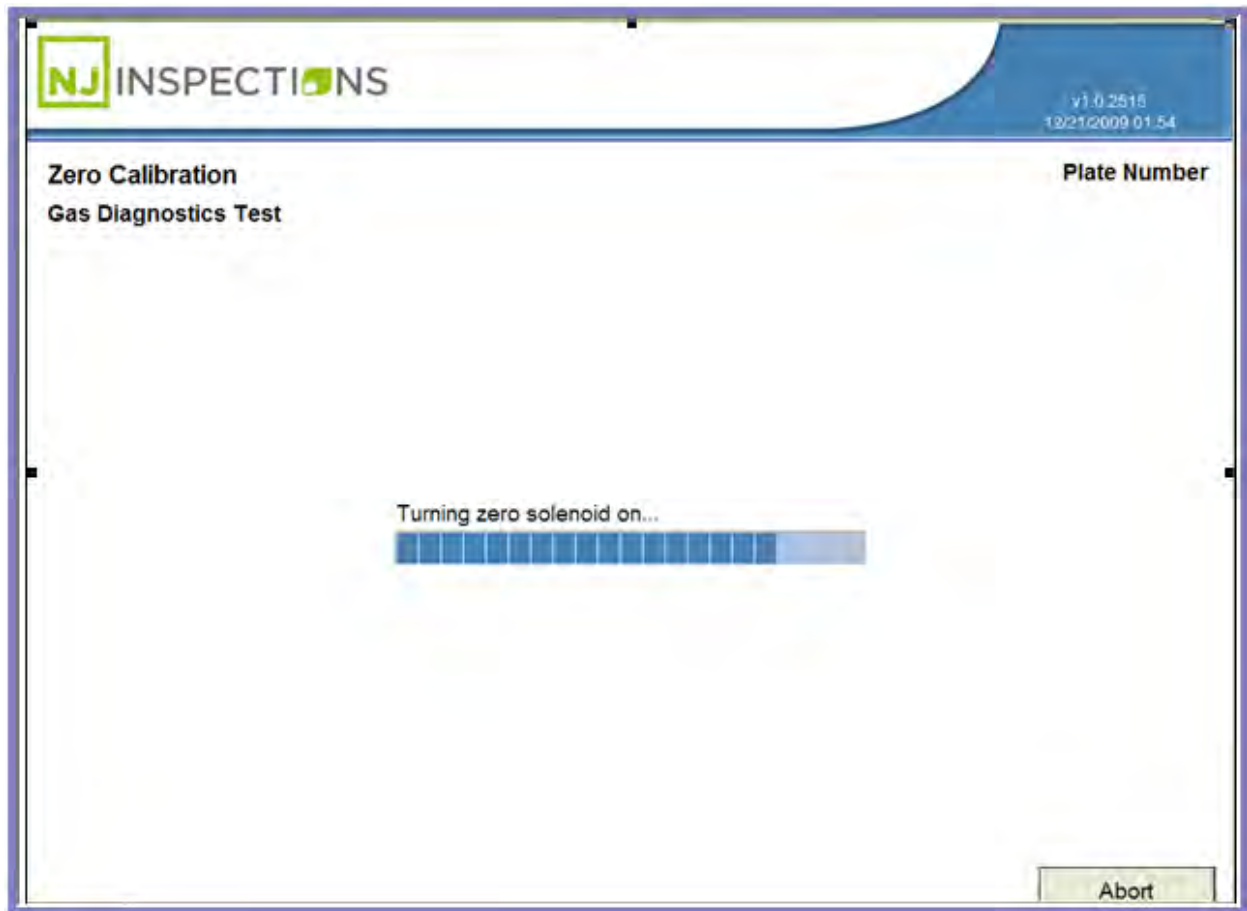

FIGURE 5-24: ZERO CALIBRATION (GAS DIAGNOSTIC TEST)

NEW JERSEY OPERATORS INSTRUCTION MANUAL

OPACITY DIAGNOSTIC TEST (2)

STEP 7. Message to turn off the zero air cylinder is displayed; Select **<OK>** to continue.

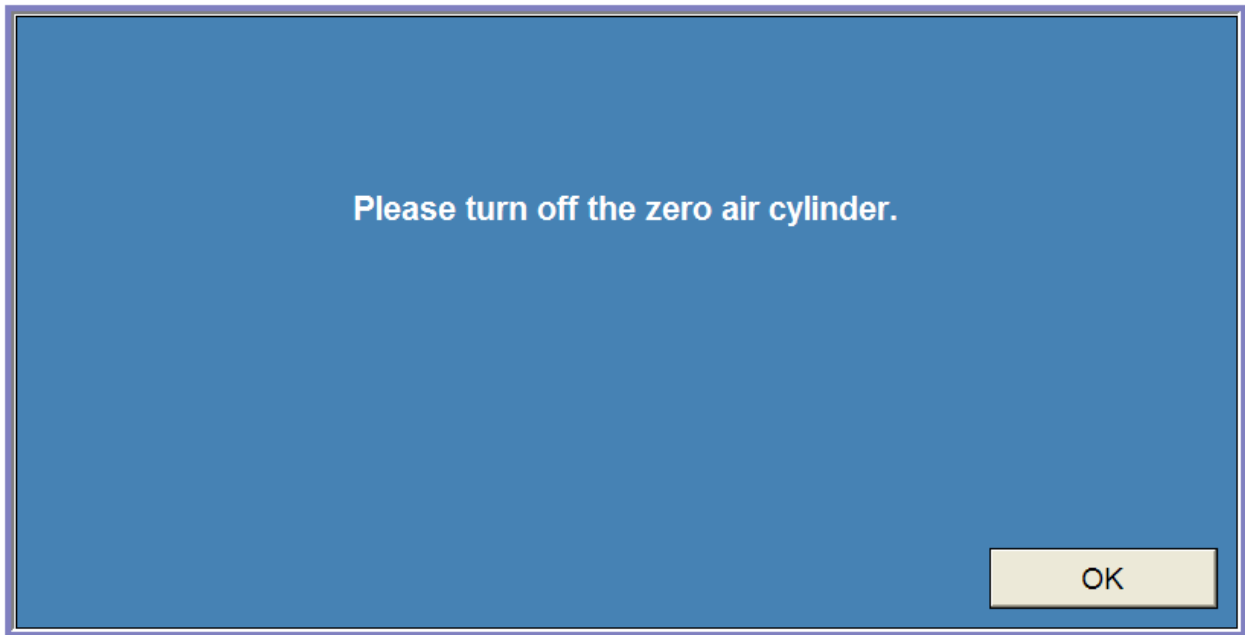

FIGURE 5-25: TURN OFF ZERO AIR CYLINDER MESSAGE

Chapter 6

Equipment Checks and Calibrations (3)

NEW JERSEY OPERATORS INSTRUCTION MANUAL

EQUIPMENT CHECKS/CALIBRATIONS MENU (3)

CHAPTER 6: EQUIPMENT CHECKS/CALIBRATIONS MENU

EQUIPMENT CHECKS AND CALIBRATIONS MENU

STEP 1. From the **Main Menu** Select **(3) Equipment Checks and Calibrations Menu**.

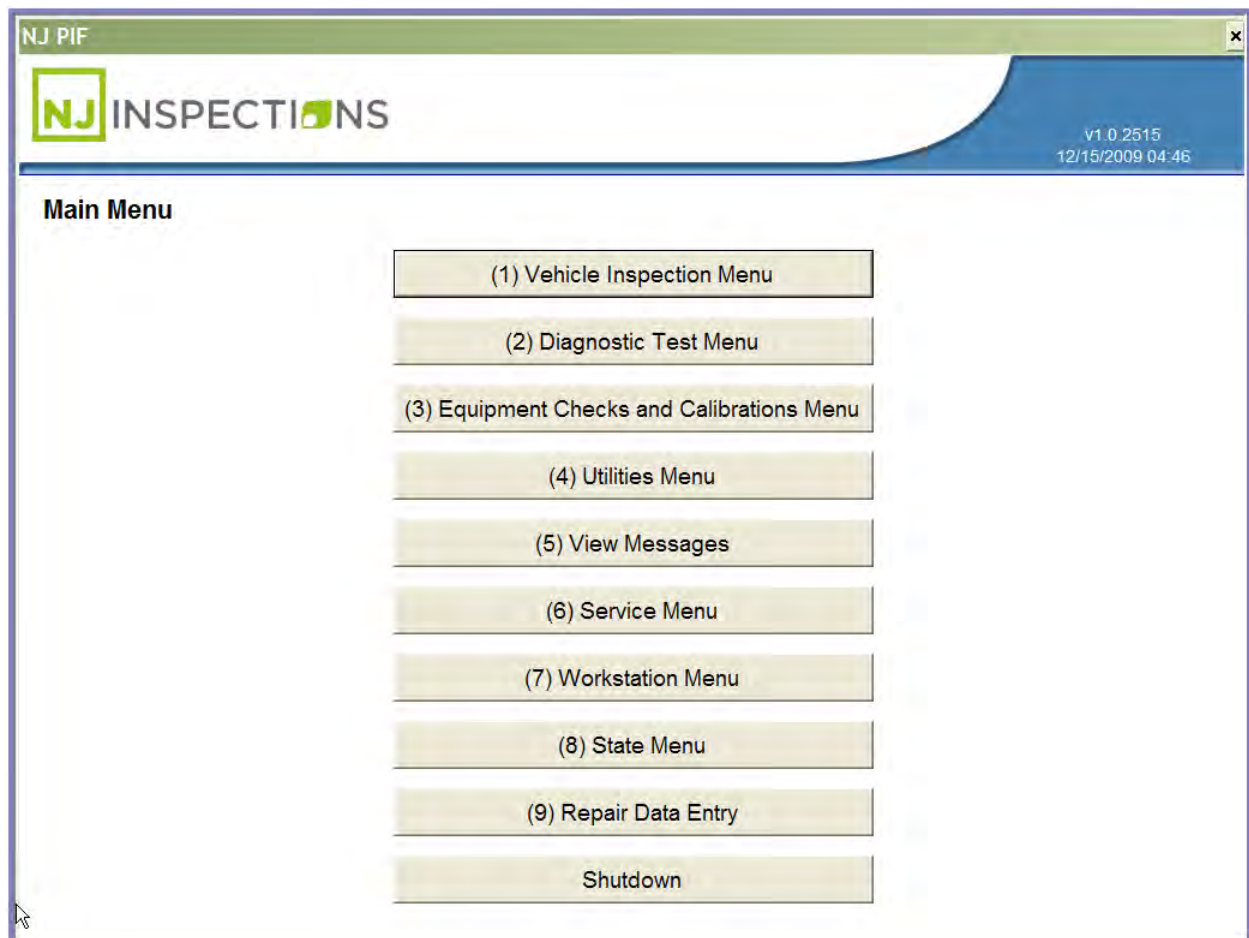

FIGURE 6-1: MAIN MENU SCREEN

NEW JERSEY OPERATORS INSTRUCTION MANUAL

EQUIPMENT CHECKS/CALIBRATIONS MENU (3)

STEP 2. Scan badge number or enter login information.

STEP 3. Click **OK** to continue.

Please Log In

1. Enter or scan badge number

2. Enter your access code

FIGURE 6-2: LOG IN SCREEN - SCAN OR ENTER BADGE/ACCESS CODE

NEW JERSEY OPERATORS INSTRUCTION MANUAL

EQUIPMENT CHECKS/CALIBRATIONS MENU (3)

(2) PRINTER AND BARCODE

STEP 4. From the **Calibration/Check Menu**, Select **(2) Printer and Barcode Scanner Check**.

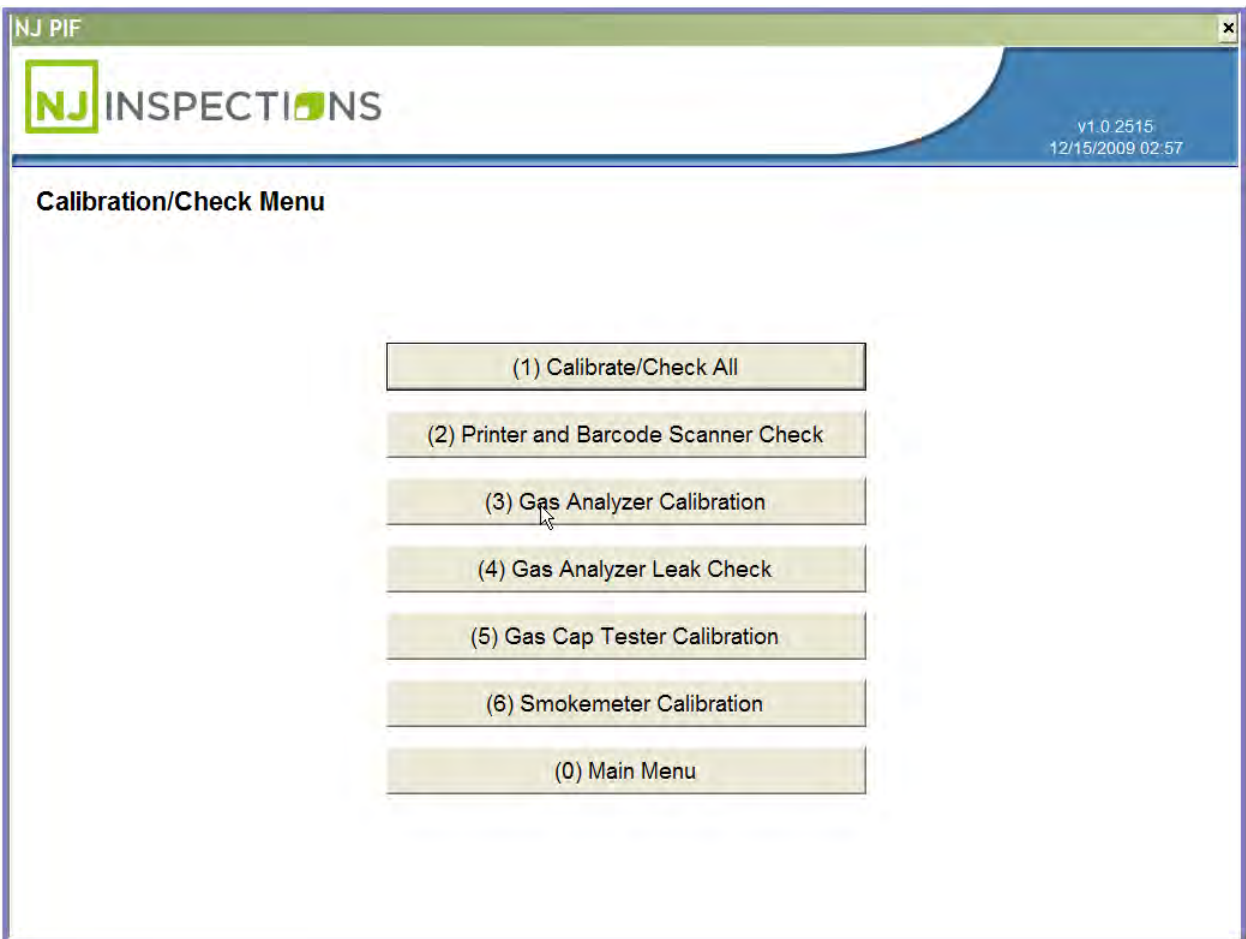

FIGURE 6-3: CALIBRATION/CHECK MENU SCREEN

NEW JERSEY OPERATORS INSTRUCTION MANUAL

EQUIPMENT CHECKS/CALIBRATIONS MENU (3)

STEP 5. Verify that the text, the 1D, and 2D barcodes have printed correctly.

STEP 6. Select **Yes** or **No**.

If Yes, continue to Step 7.

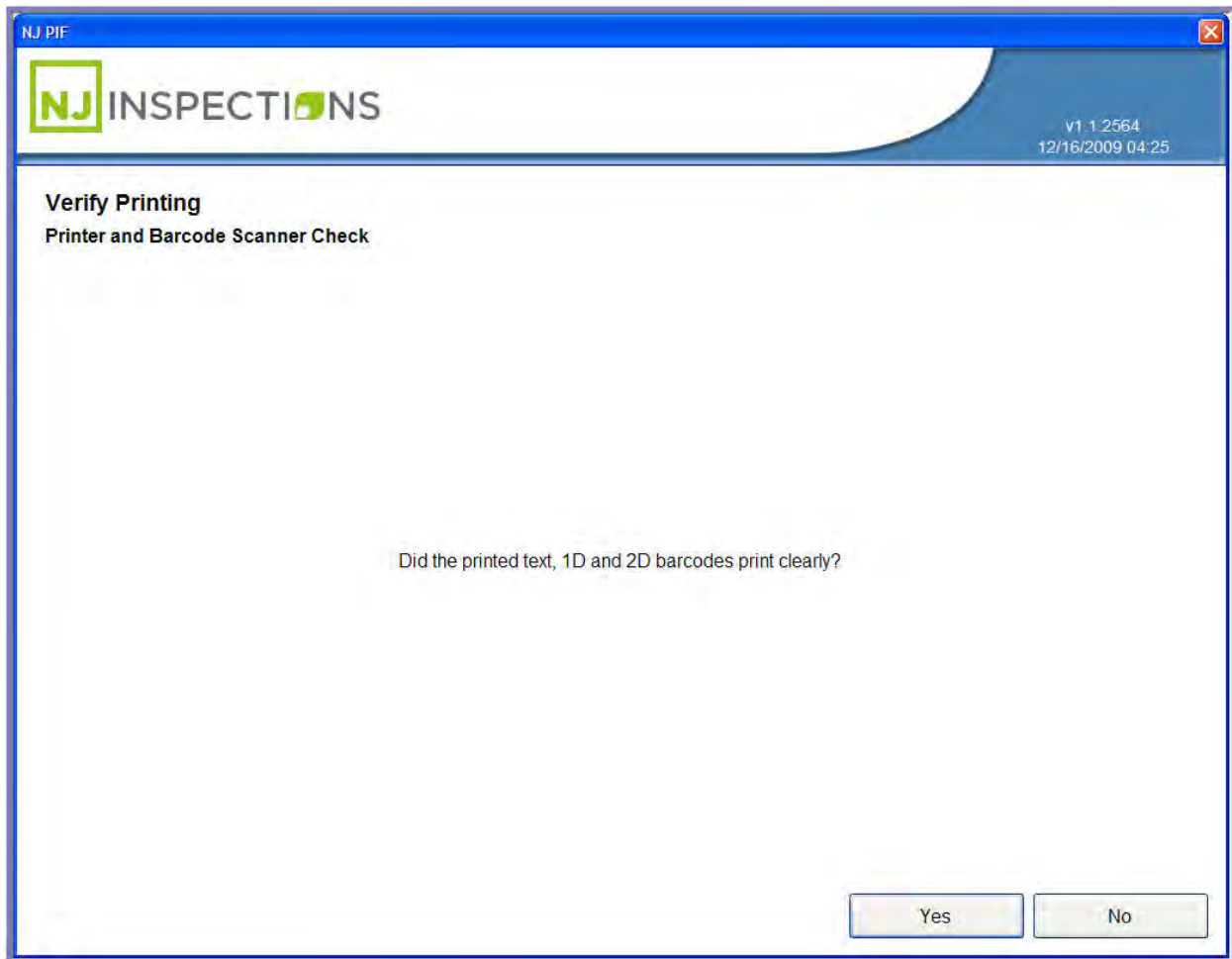

FIGURE 6-4: VERIFY PRINTING "PRINTER AND BARCODE SCANNER CHECK" SCREEN

NEW JERSEY OPERATORS INSTRUCTION MANUAL

EQUIPMENT CHECKS/CALIBRATIONS MENU (3)

STEP 7. Scan the 1D barcode on the printer test page.

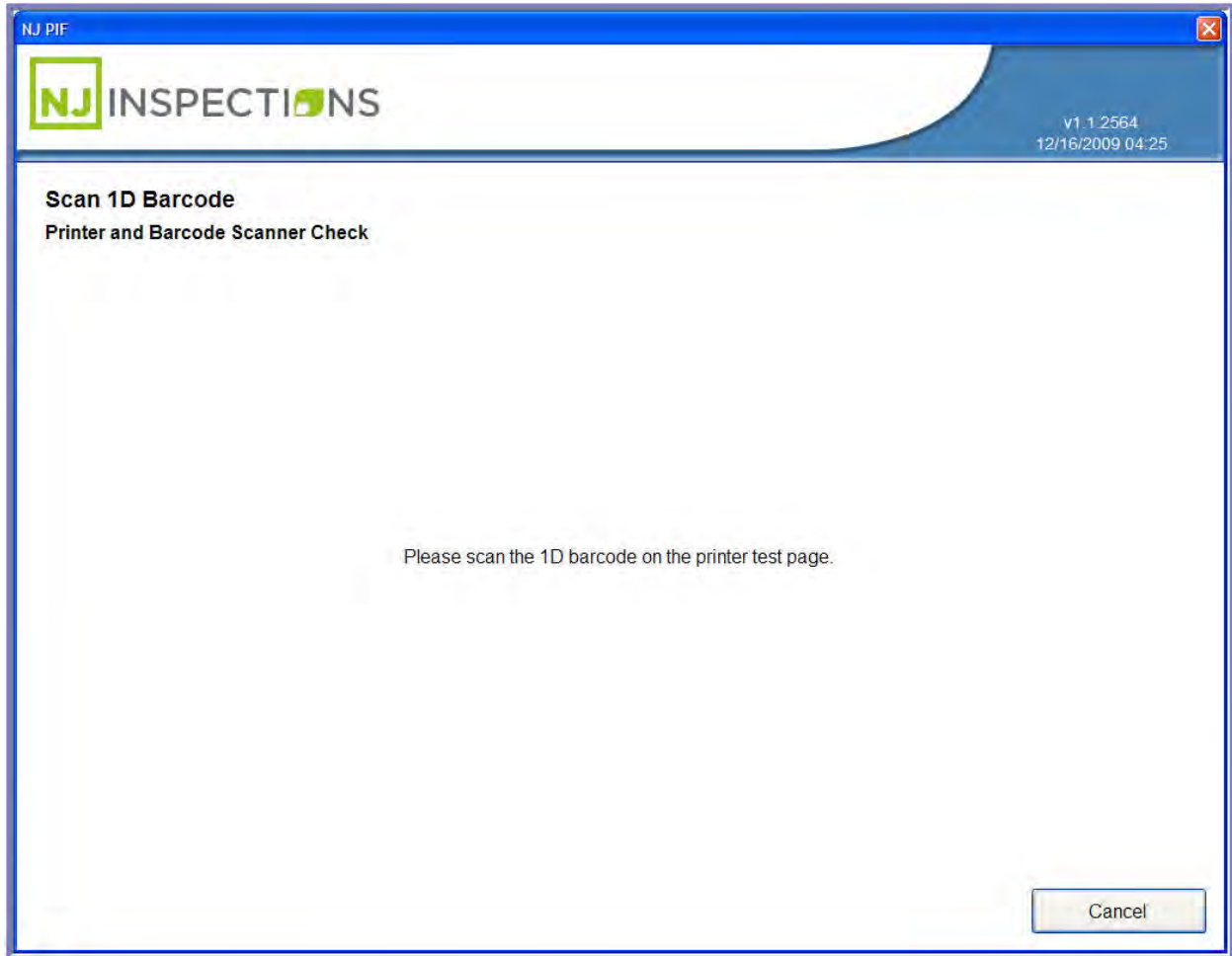

FIGURE 6-5: SCAN 1D BARCODE "PRINTER AND BARCODE SCANNER CHECK" SCREEN

NEW JERSEY OPERATORS INSTRUCTION MANUAL

EQUIPMENT CHECKS/CALIBRATIONS MENU (3)

STEP 8. Verify your Barcode scanner and Printer Equipment check results.

STEP 9. Click OK.

Please note, example below illustrates a failed result. If pass, screen will display

Barcode scanner: Passed.

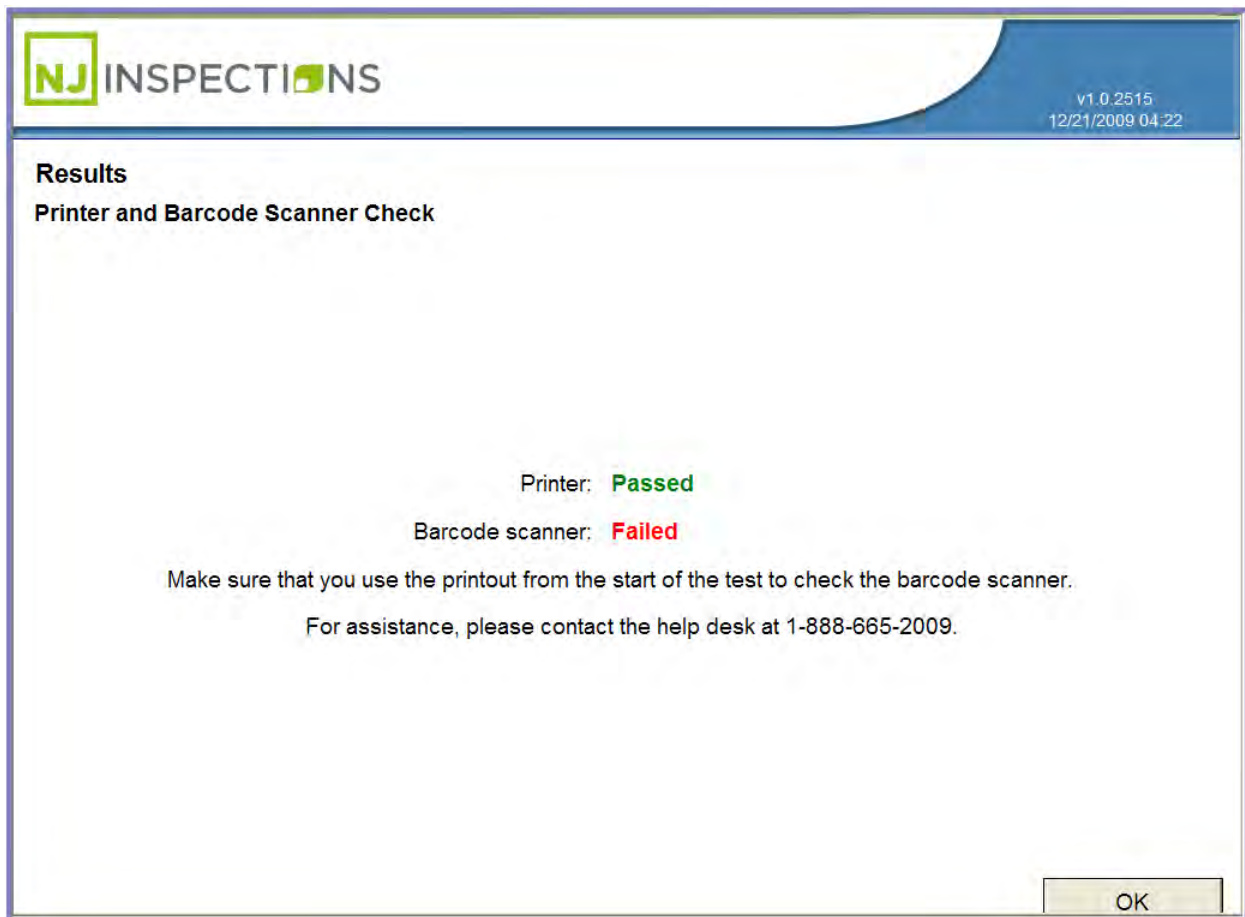

FIGURE 6-6: RESULTS "PRINTER AND BARCODE SCANNER CHECK" SCREEN

NEW JERSEY OPERATORS INSTRUCTION MANUAL

EQUIPMENT CHECKS/CALIBRATIONS MENU (3)

STEP 10. Completed Calibration test message will be displayed, **Select <OK>** to return to the **Calibration/Check Menu**.

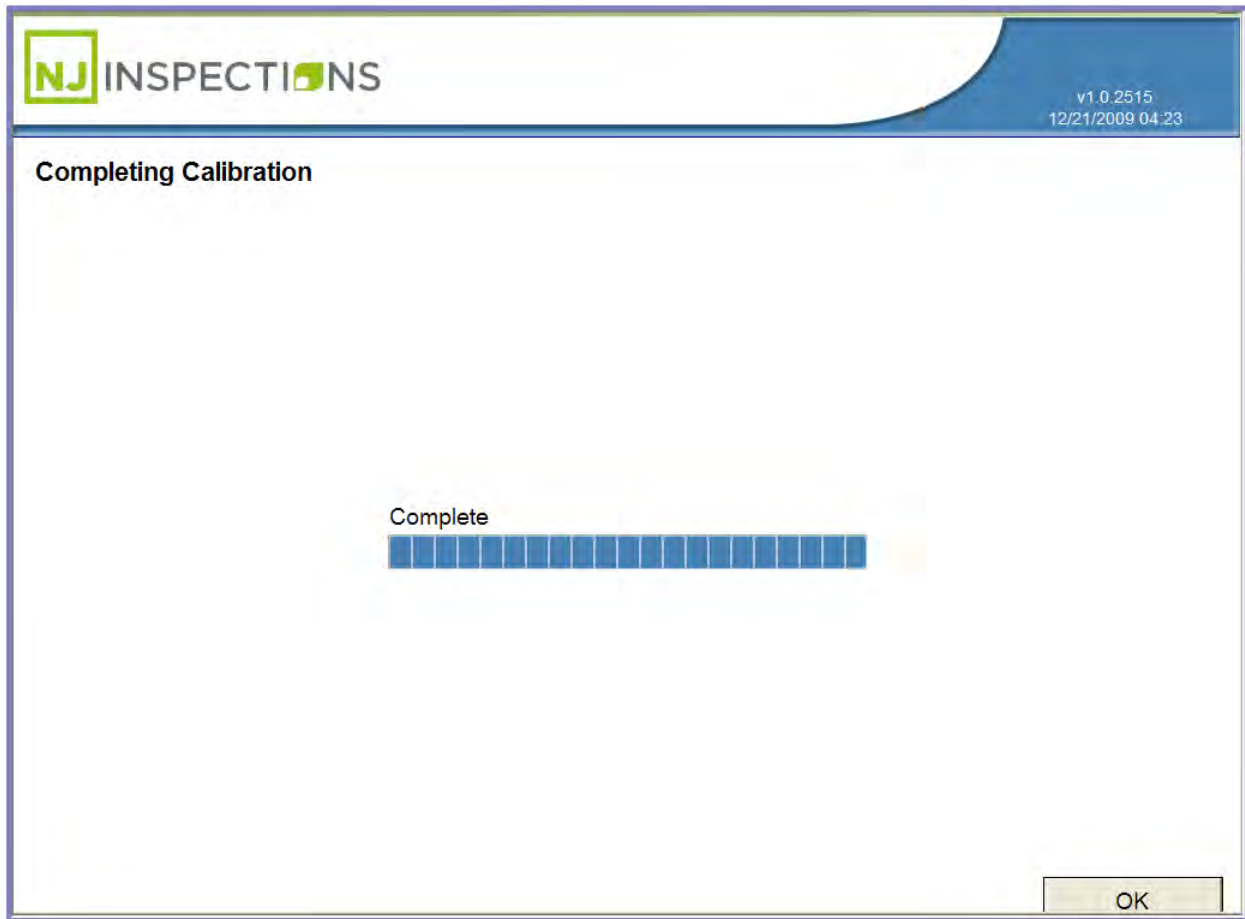

FIGURE 6-7: COMPLETING CALIBRATION COMPLETED MESSAGE

Chapter 7

The Utilities

Menu (4)

NEW JERSEY OPERATORS INSTRUCTION MANUAL

UTILITIES MENU (4)

CHAPTER 7: THE UTILITIES MENU

UTILITIES MENU

From the **Main Menu** select **(4) Utilities Menu**.

Within the **(4) Utilities menu** option there are several functions available, see the different options below in Figure 7-1 to Figure 7-7.

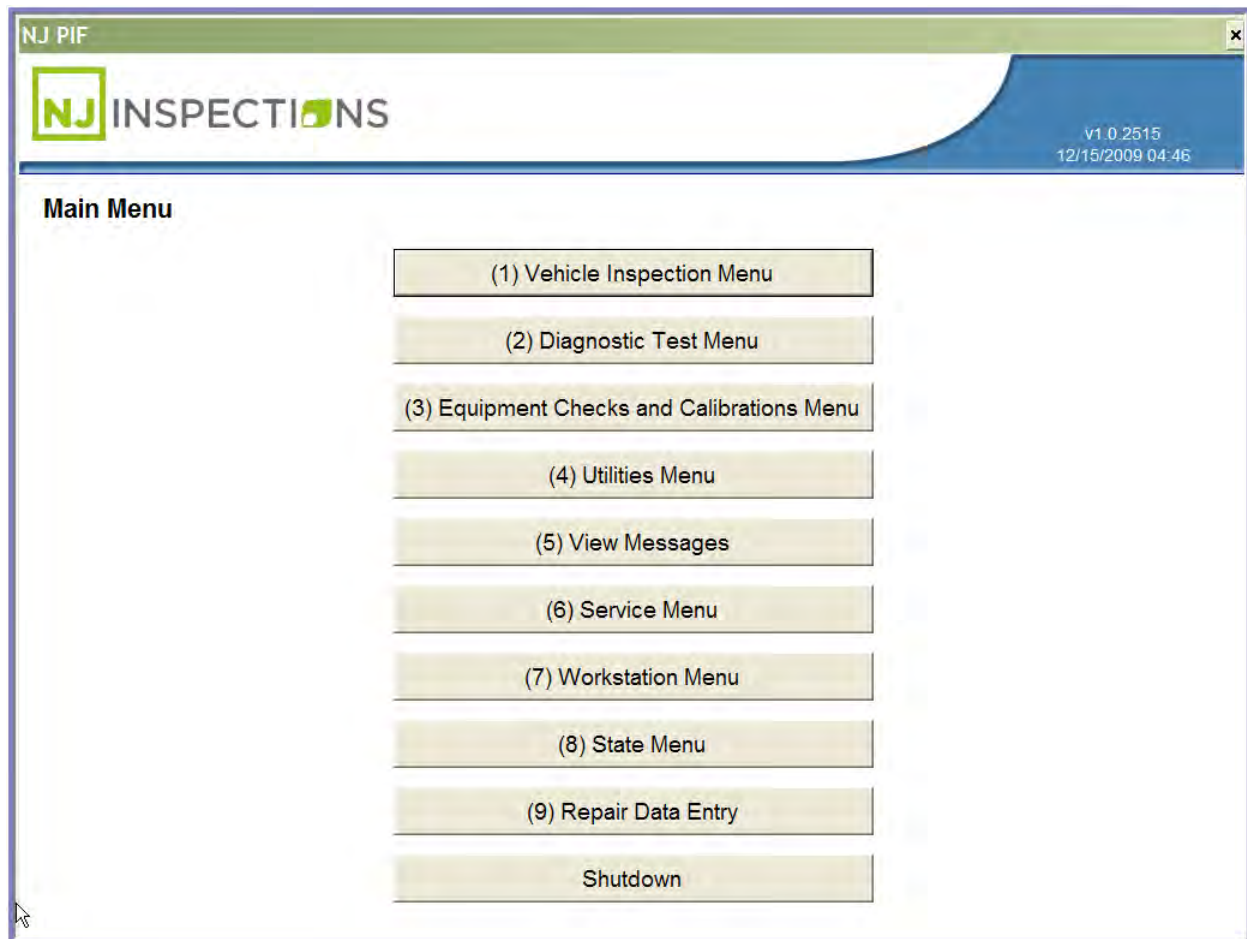

FIGURE 7-1: MAIN MENU SCREEN

NEW JERSEY OPERATORS INSTRUCTION MANUAL

UTILITIES MENU (4)

(1) DATA FILE REFRESH FROM THE UTILITIES MENU

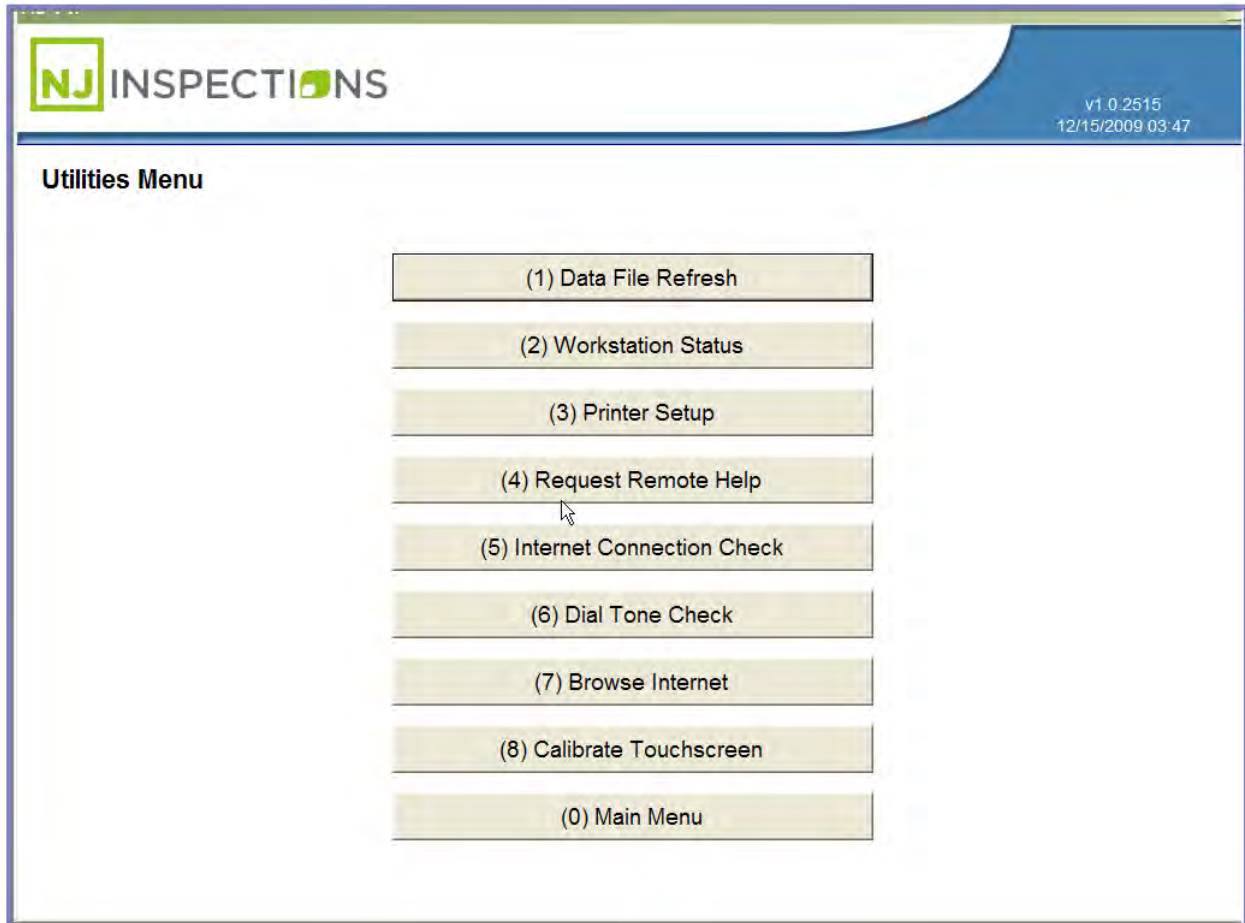

FIGURE 7-2: UTILITIES MENU

NEW JERSEY OPERATORS INSTRUCTION MANUAL

UTILITIES MENU (4)

DATA FILE REFRESH MESSAGE

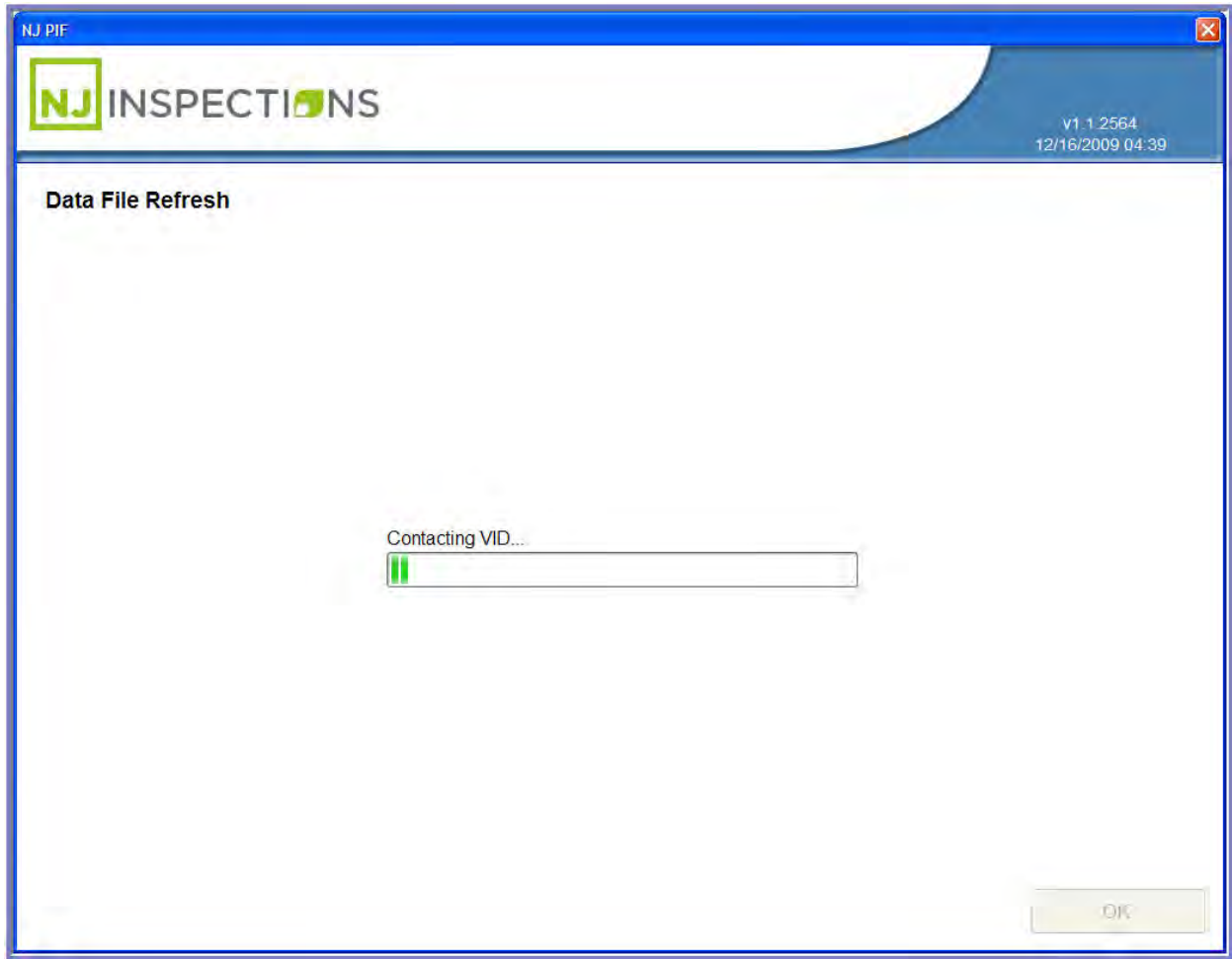

FIGURE 7-3: DATA FILE REFRESH SCREEN

NEW JERSEY OPERATORS INSTRUCTION MANUAL

UTILITIES MENU (4)

(2) WORKSTATION STATUS SCREEN FROM THE UTILITIES MENU.

NJ INSPECTIONS v0.1.1316
07/20/2009 09:32

Workstation Status

Facility license ID:	PIF123456	Hardware Configuration	
Workstation ID:	SG213456	OBDII SN:	SN1234
Software version:	0.1.1316	Gas cap tester SN:	N/A
EIS connection:	Online	Gas Analyzer SN:	N/A
Workstation status:	Active	Smokemeter SN:	N/A

Calibration

Gas analyzer leak check		Other Lockouts	
Last performed:	N/A		
Next time due:	N/A		
Gas analyzer calibration			
Last performed:	N/A		
Next time due:	N/A		
Gas cap tester calibration			
Last performed:	N/A		
Next time due:	7/20/2009 9:32:36 PM		
Smokemeter calibration			
Last performed:	N/A		
Next time due:	N/A		

FIGURE 7-4: WORKSTATION STATUS SCREEN

NEW JERSEY OPERATORS INSTRUCTION MANUAL

UTILITIES MENU (4)

(3) PRINTER SETUP SCREEN FROM THE UTILITIES MENU

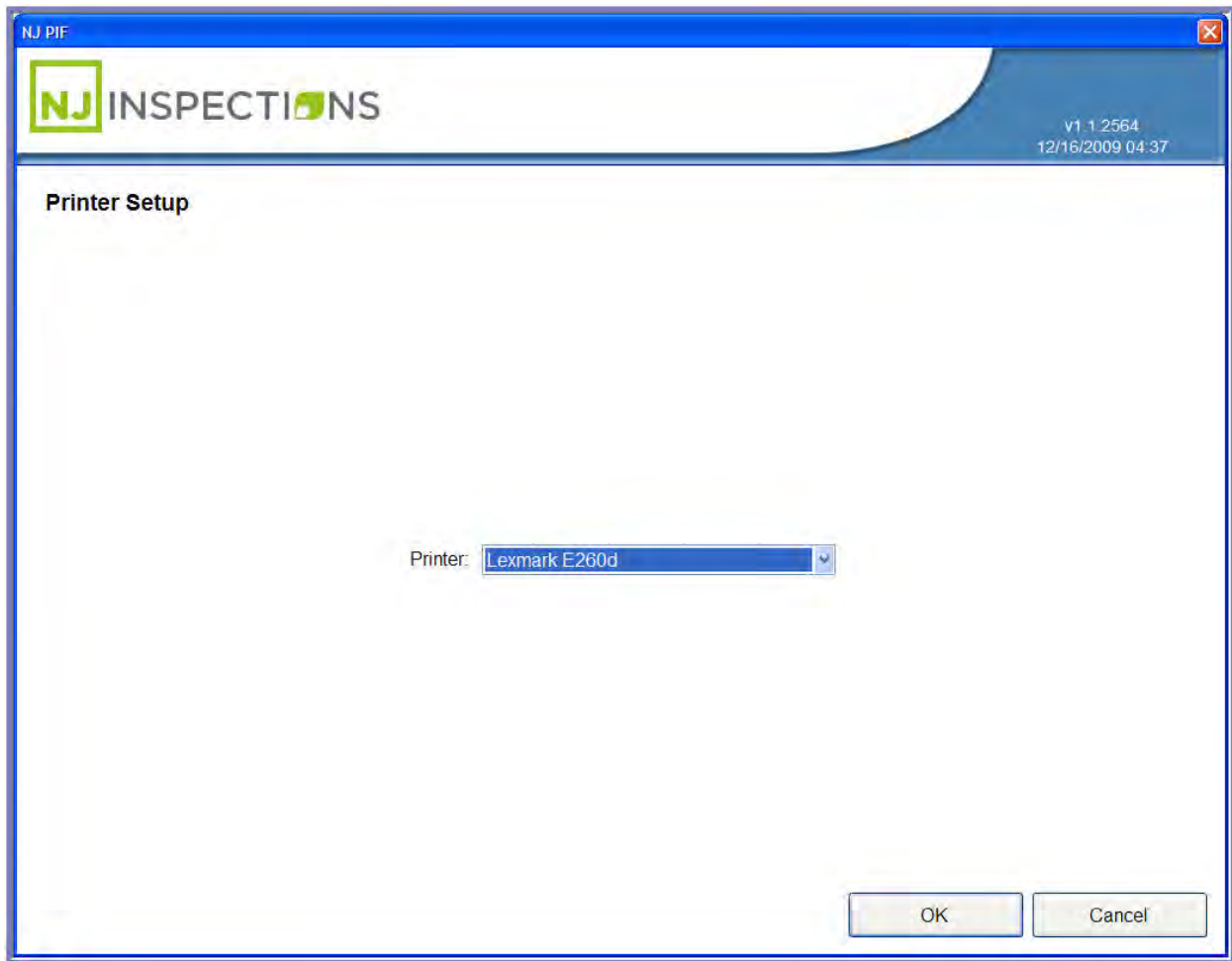

FIGURE 7-5: PRINTER SETUP SCREEN OPTION

NEW JERSEY OPERATORS INSTRUCTION MANUAL

UTILITIES MENU (4)

(4) REQUEST REMOTE HELP SCREEN FROM THE UTILITIES MENU

- You will be prompted to enter the daily password, which must be requested by the helpdesk.
- **Click OK** to continue.

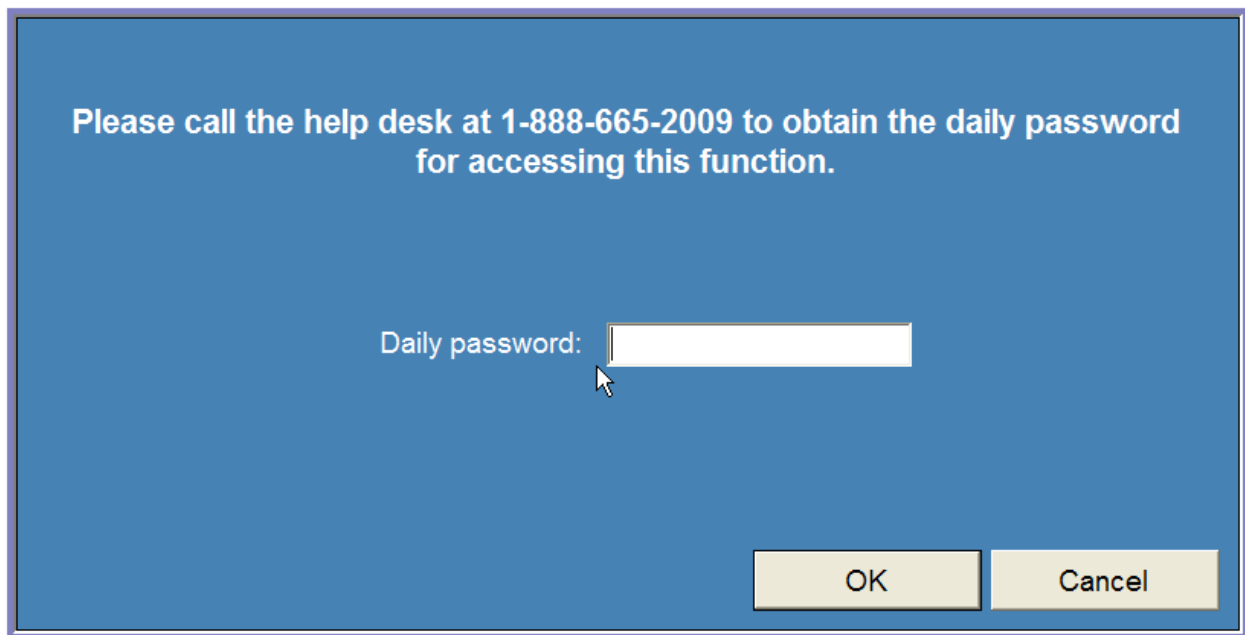

Please call the help desk at 1-888-665-2009 to obtain the daily password for accessing this function.

Daily password:

OK Cancel

FIGURE 7-6: REQUEST REMOTE HELP SCREEN ENTRY

1. Once the daily password is entered and you choose **<OK>** you will be returned to the Utilities Menu.

NEW JERSEY OPERATORS INSTRUCTION MANUAL

UTILITIES MENU (4)

(5) INTERNET CONNECTION CHECK SCREEN FROM THE FROM THE UTILITIES MENU

- Verify your connection if any problems contact the help desk at 1-888-665-2009.
- Click **OK** to return to the Utilities Menu.

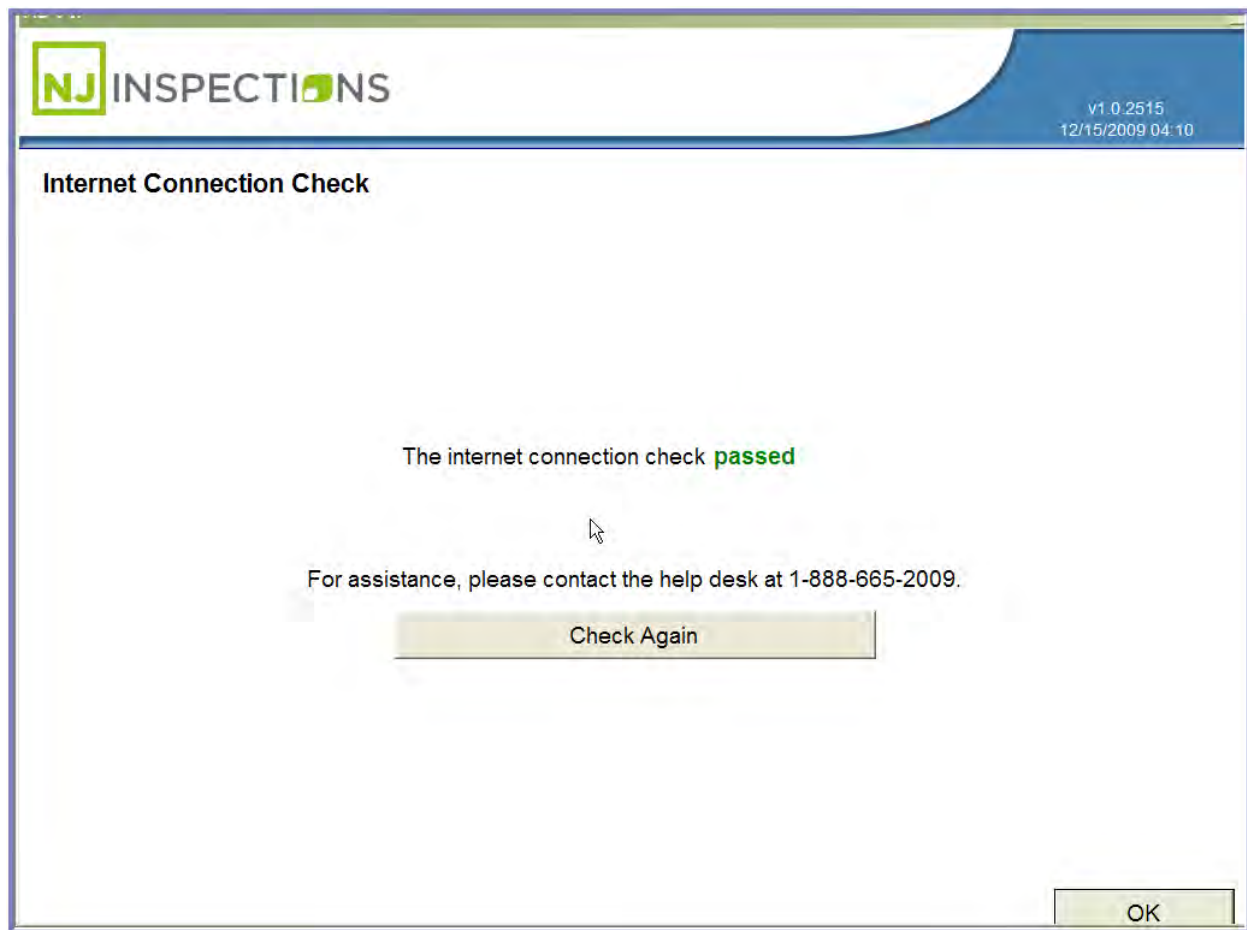

FIGURE 7-7: INTERNET CONNECTION CHECK SCREEN

NEW JERSEY OPERATORS INSTRUCTION MANUAL

UTILITIES MENU (4)

(6) DIAL TONE CHECK SCREEN FROM THE FROM THE UTILITIES MENU

- If any problems with connection contact the help desk at 1-888-665-2009
- Click **OK** to return to the **Utilities Menu**.

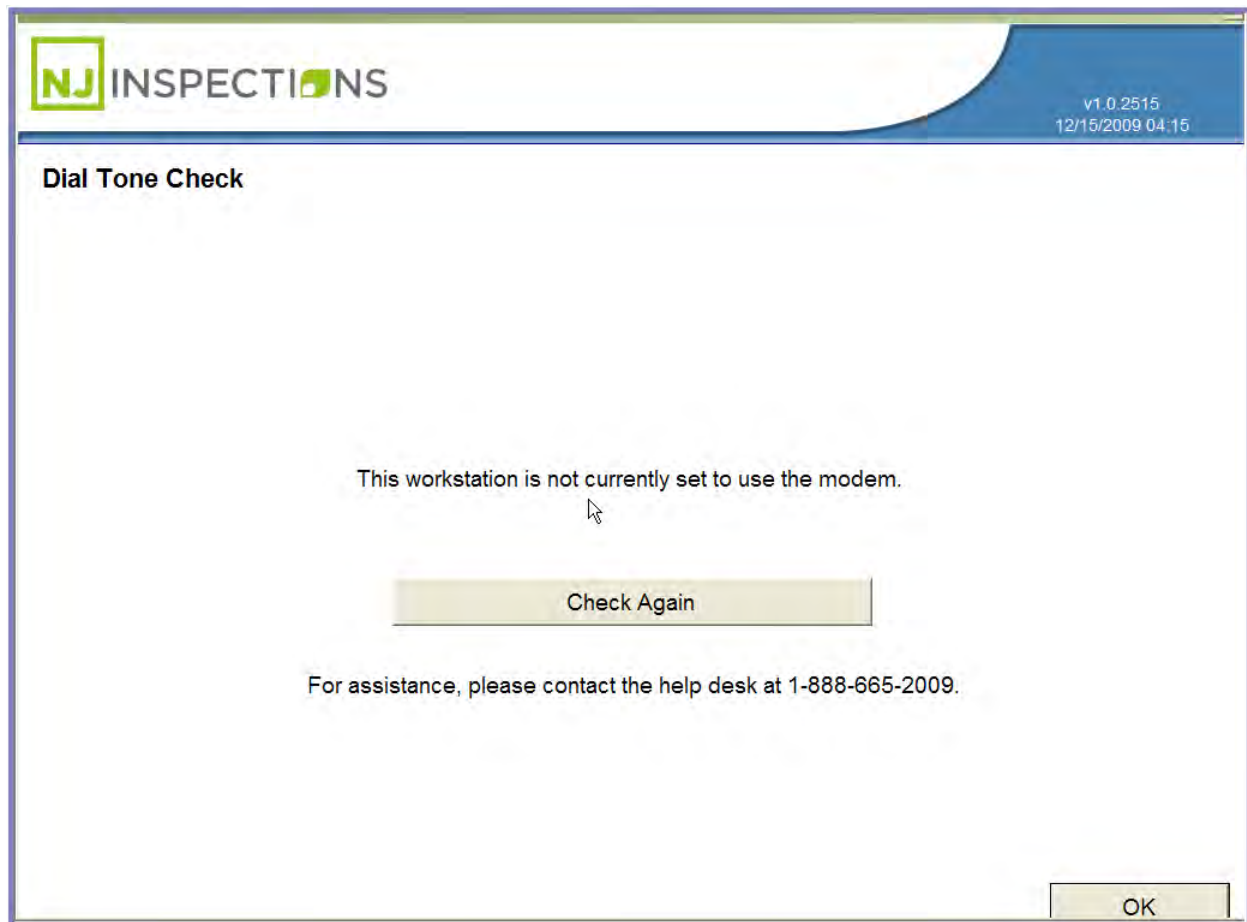
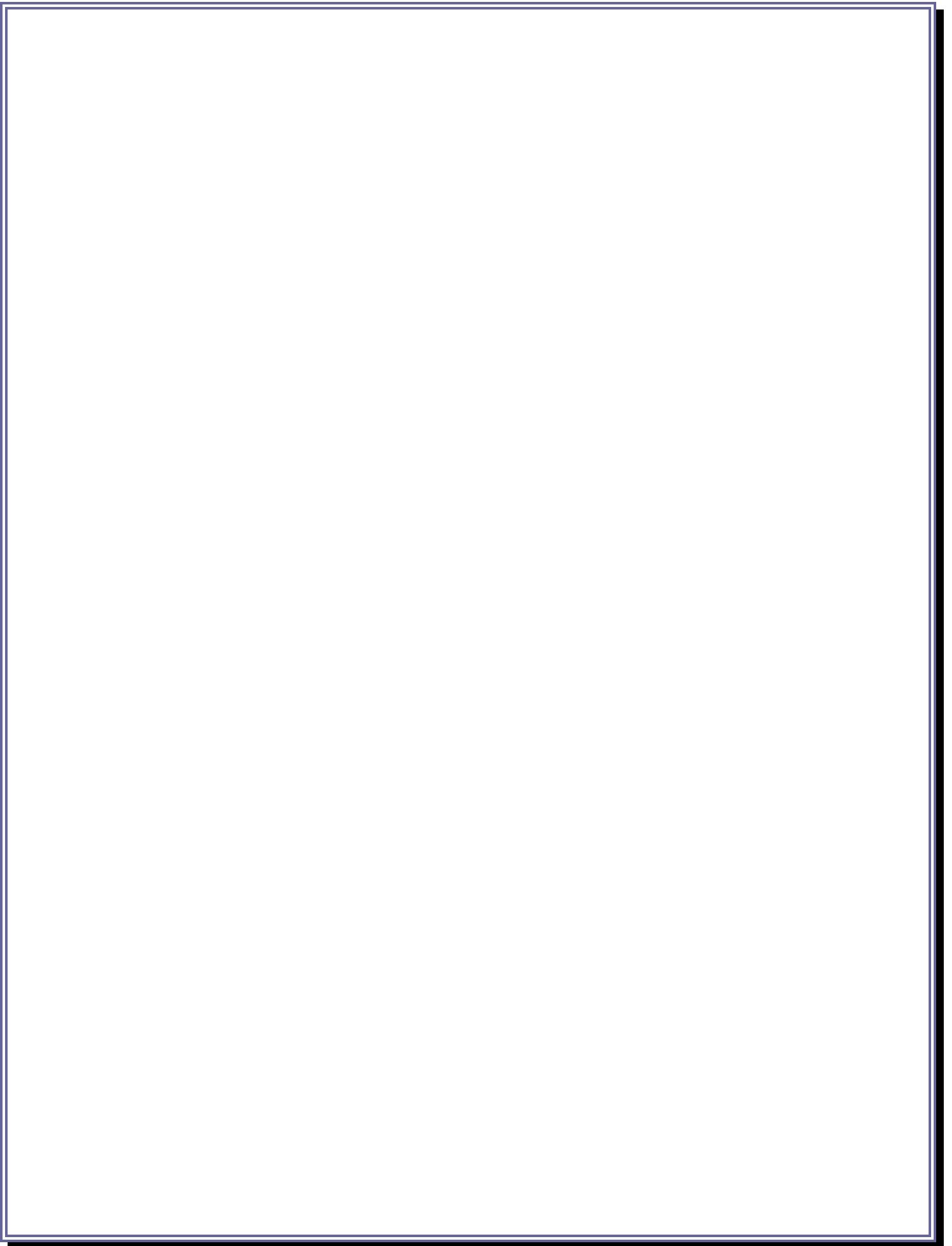

FIGURE 7-8: DIAL TONE CHECK SCREEN



Chapter 8

View

Messages

(5)

NEW JERSEY OPERATORS INSTRUCTION MANUAL

VIEW MESSAGES (5)

CHAPTER 8: VIEW MESSAGES

1. From the **Main Menu**, select **(5) Messages**.

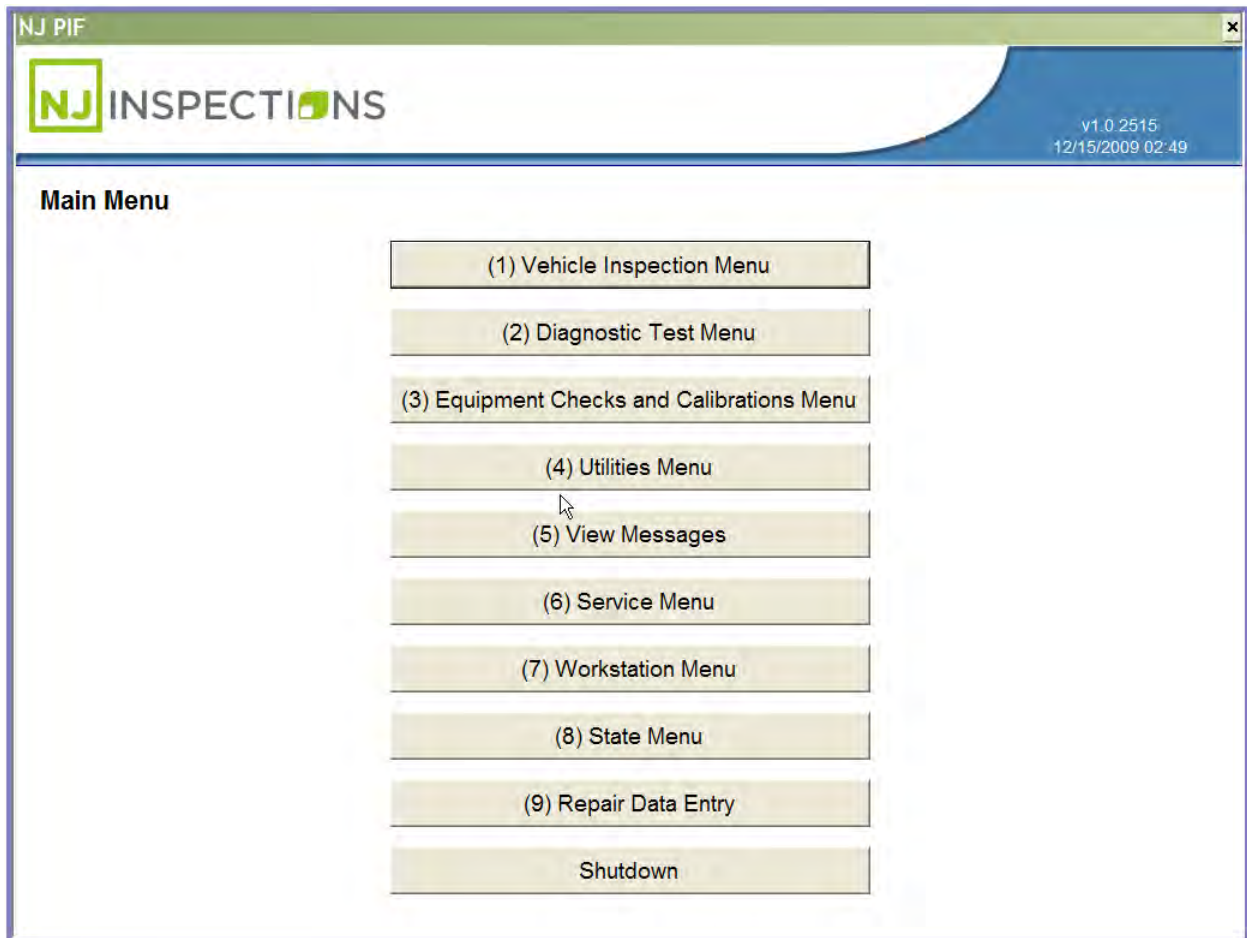

FIGURE 8-1: MAIN MENU SCREEN

NEW JERSEY OPERATORS INSTRUCTION MANUAL

VIEW MESSAGES (5)

2. All messages will be listed with the newest message listed first. All messages are listed in order of the date they were sent.
3. **Click on the message** you wish to view and **select OK**.

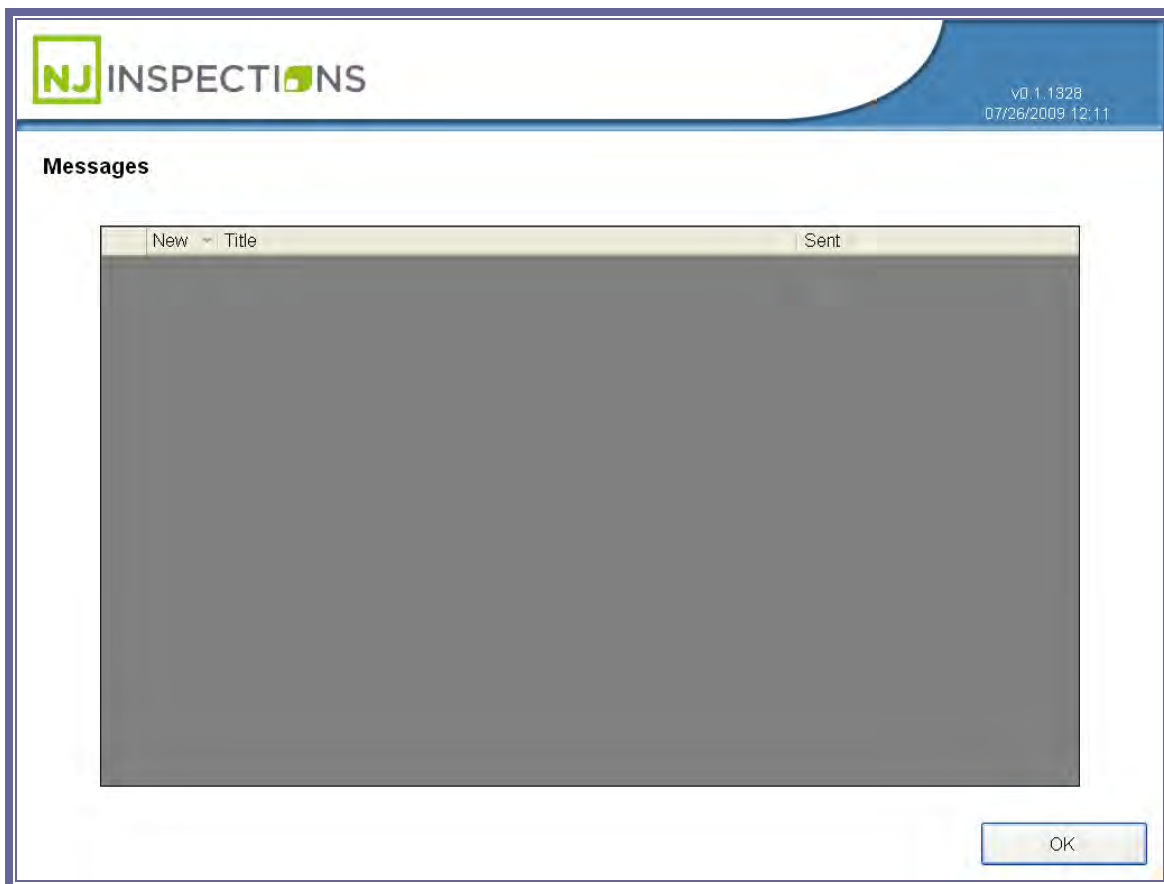

FIGURE 8-2: MESSAGES SCREEN

Chapter 9

The Workstation Management Menu (7)

NEW JERSEY OPERATORS INSTRUCTION MANUAL

THE WORKSTATION MANAGEMENT MENU (7)

CHAPTER 9: THE WORKSTATION MANAGEMENT MENU

1. From the **Main Menu**, select **(7) Workstation Management Menu**.

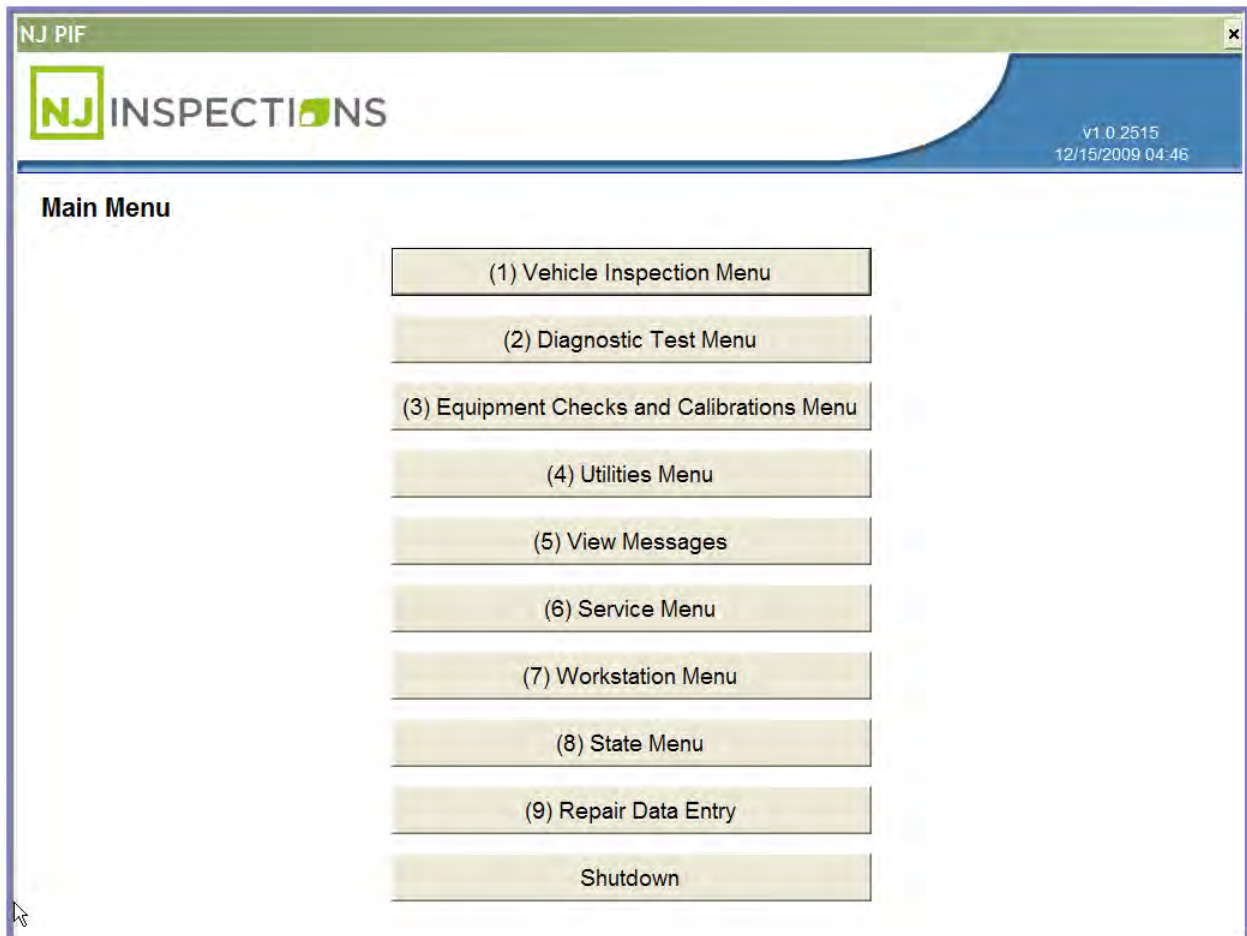
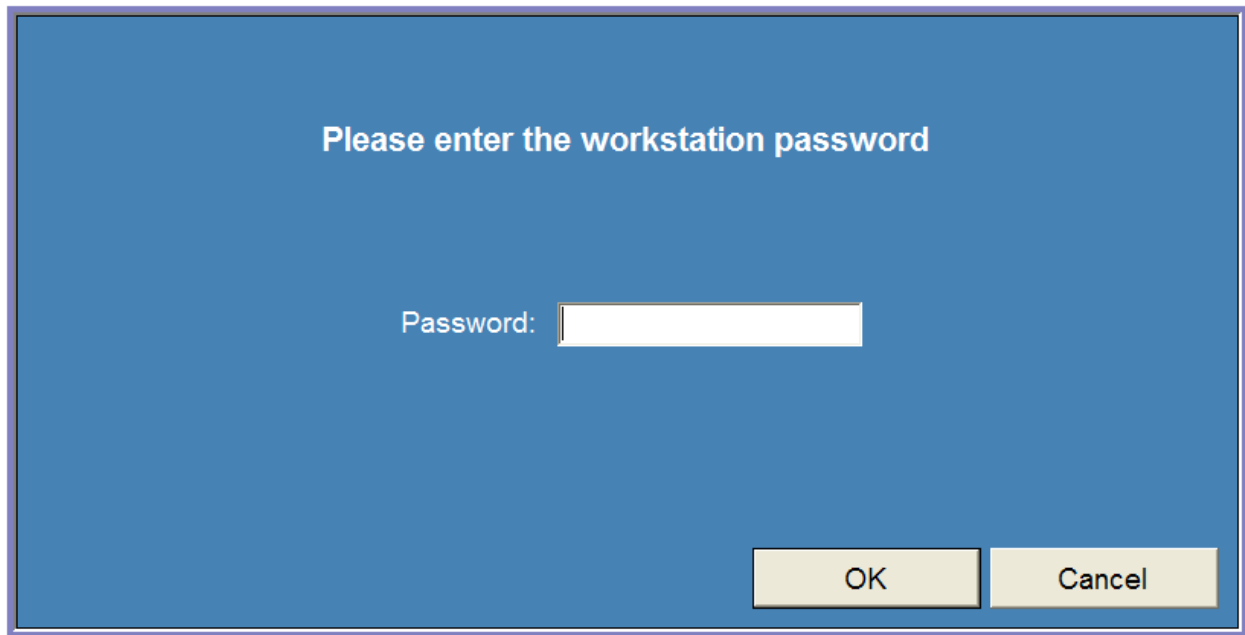

FIGURE 9-1: MAIN MENU SCREEN

NEW JERSEY OPERATORS INSTRUCTION MANUAL

THE WORKSTATION MANAGEMENT MENU (7)

2. Enter Workstation password to continue.



The screenshot shows a blue dialog box with the text "Please enter the workstation password" centered at the top. Below this text is a label "Password:" followed by a white rectangular input field. At the bottom right of the dialog box are two buttons: "OK" and "Cancel".

FIGURE 9-2: WORKSTATION PASSWORD SCREEN

NEW JERSEY OPERATORS INSTRUCTION MANUAL

THE WORKSTATION MANAGEMENT MENU (7)

From the **Workstation Management Menu**, select option (1) **Data File Refresh**.



FIGURE 9-3: WORKSTATION MANAGEMENT MENU SCREEN

NEW JERSEY OPERATORS INSTRUCTION MANUAL

THE WORKSTATION MANAGEMENT MENU (7)

(1) DATA FILE REFRESH SCREEN

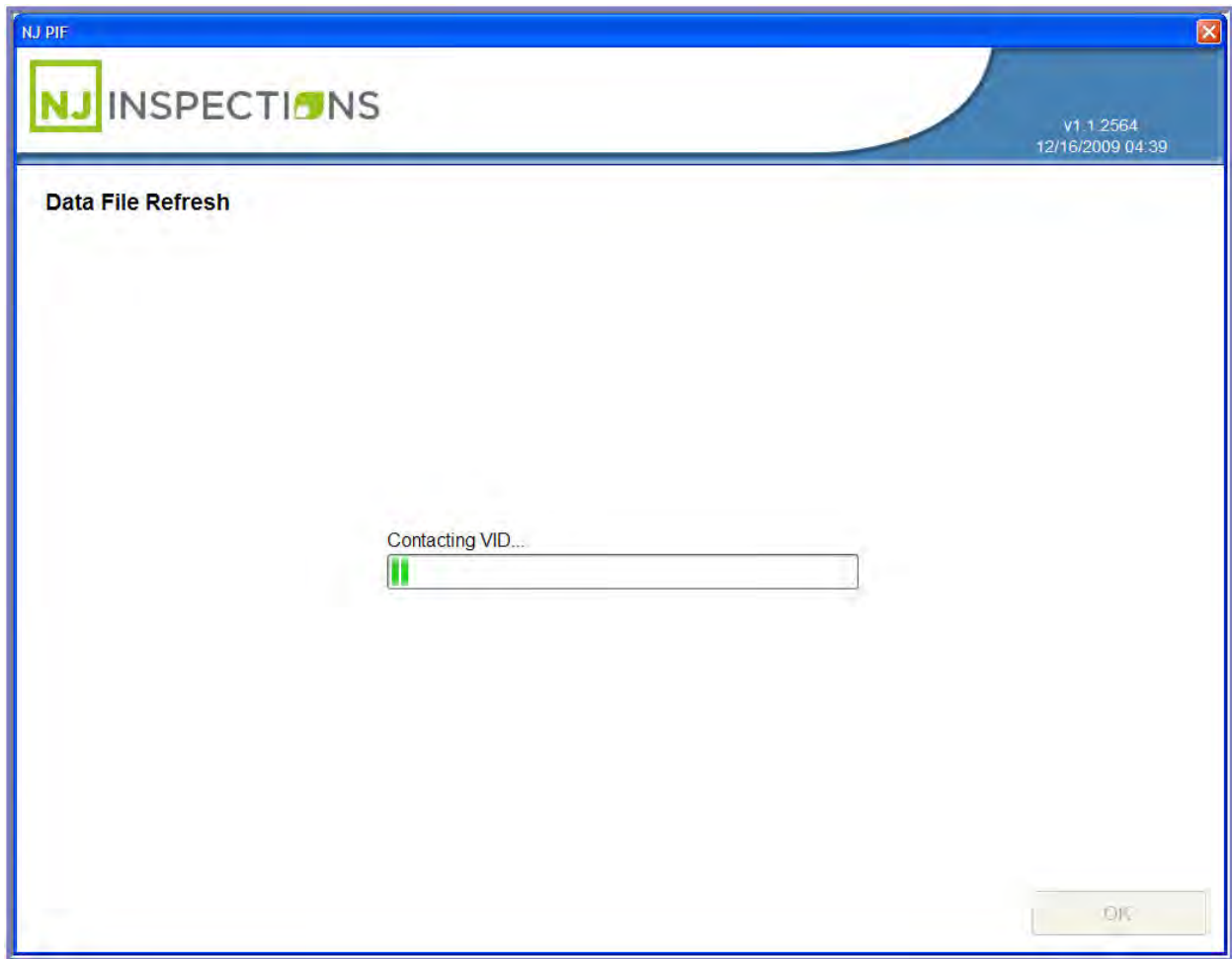

FIGURE 9-4: DATA FILE REFRESH SCREEN

NEW JERSEY OPERATORS INSTRUCTION MANUAL

THE WORKSTATION MANAGEMENT MENU (7)

(2) CHANGE WORKSTATION PASSWORD

- Enter new password and confirm click <OK> to complete change and return to the Workstation Menu.

The screenshot shows a software dialog box titled "Change Workstation Password". The top-left corner features the "NJ INSPECTIONS" logo. The top-right corner displays version and date information: "v0.1.1316" and "07/20/2009 09:42". The main content area contains the text "Change Workstation Password" followed by two input fields: "New password:" and "Confirm password:". At the bottom right, there are two buttons: "OK" and "Cancel".

FIGURE 9-5: CHANGE WORKSTATION PASSWORD SCREEN

NEW JERSEY OPERATORS INSTRUCTION MANUAL

THE WORKSTATION MANAGEMENT MENU (7)

(3) EQUIPMENT MAINTENANCE

- Enter equipment information and click **OK** to return to the Workstation Management Menu.

NJ INSPECTIONS v0.1.1328
07/26/2009 11:40

Equipment Maintenance

Servicer name:

Service request date: 7/26/2009 ▼

Initial service date: 7/26/2009 ▼

Service reason:

Service item:

Serial number:

Work performed:

Problem resolved:

Return visit required:

OK Cancel

FIGURE 9-6: EQUIPMENT MAINTENANCE SCREEN

NEW JERSEY OPERATORS INSTRUCTION MANUAL

THE WORKSTATION MANAGEMENT MENU (7)

(4) UPDATE SOFTWARE FROM CD

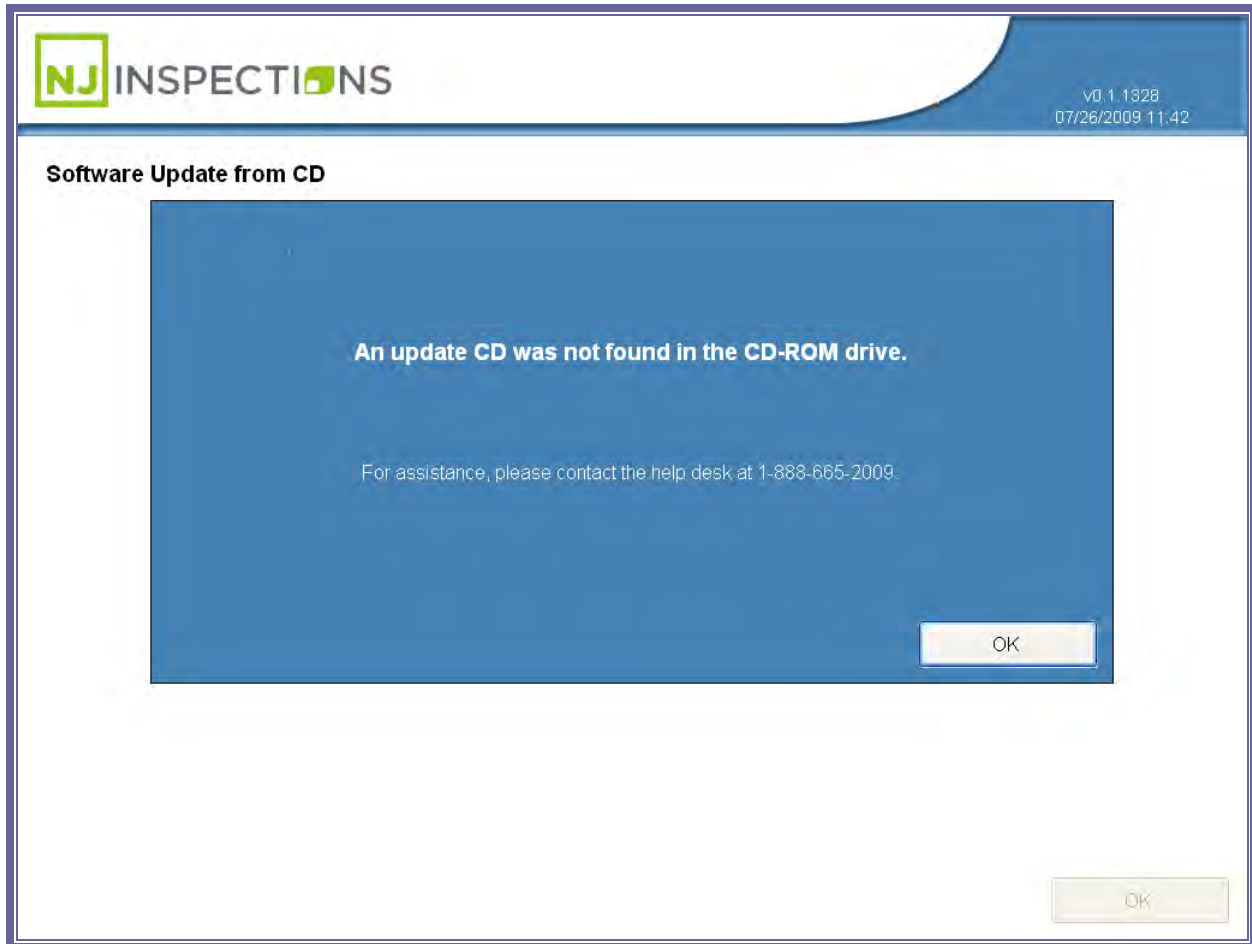

FIGURE 9-7: SOFTWARE UPDATE FROM CD SCREEN

NEW JERSEY OPERATORS INSTRUCTION MANUAL

THE WORKSTATION MANAGEMENT MENU (7)

(5) INTERNET ACCESS SETUP

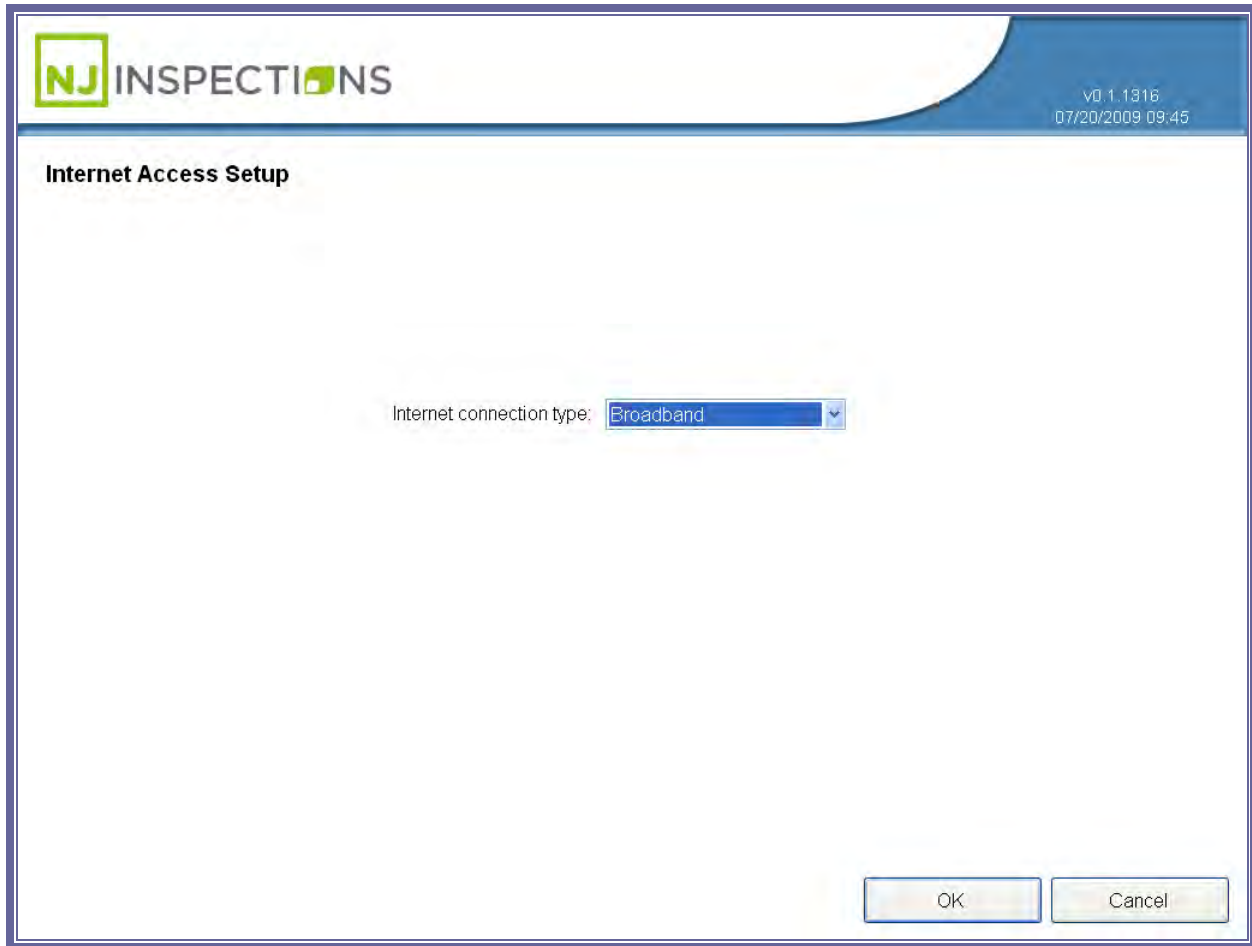

FIGURE 9-8: INTERNET ACCESS SETUP SCREEN

NEW JERSEY OPERATORS INSTRUCTION MANUAL

THE WORKSTATION MANAGEMENT MENU (7)

(6) INTERNET CONNECTION CHECK

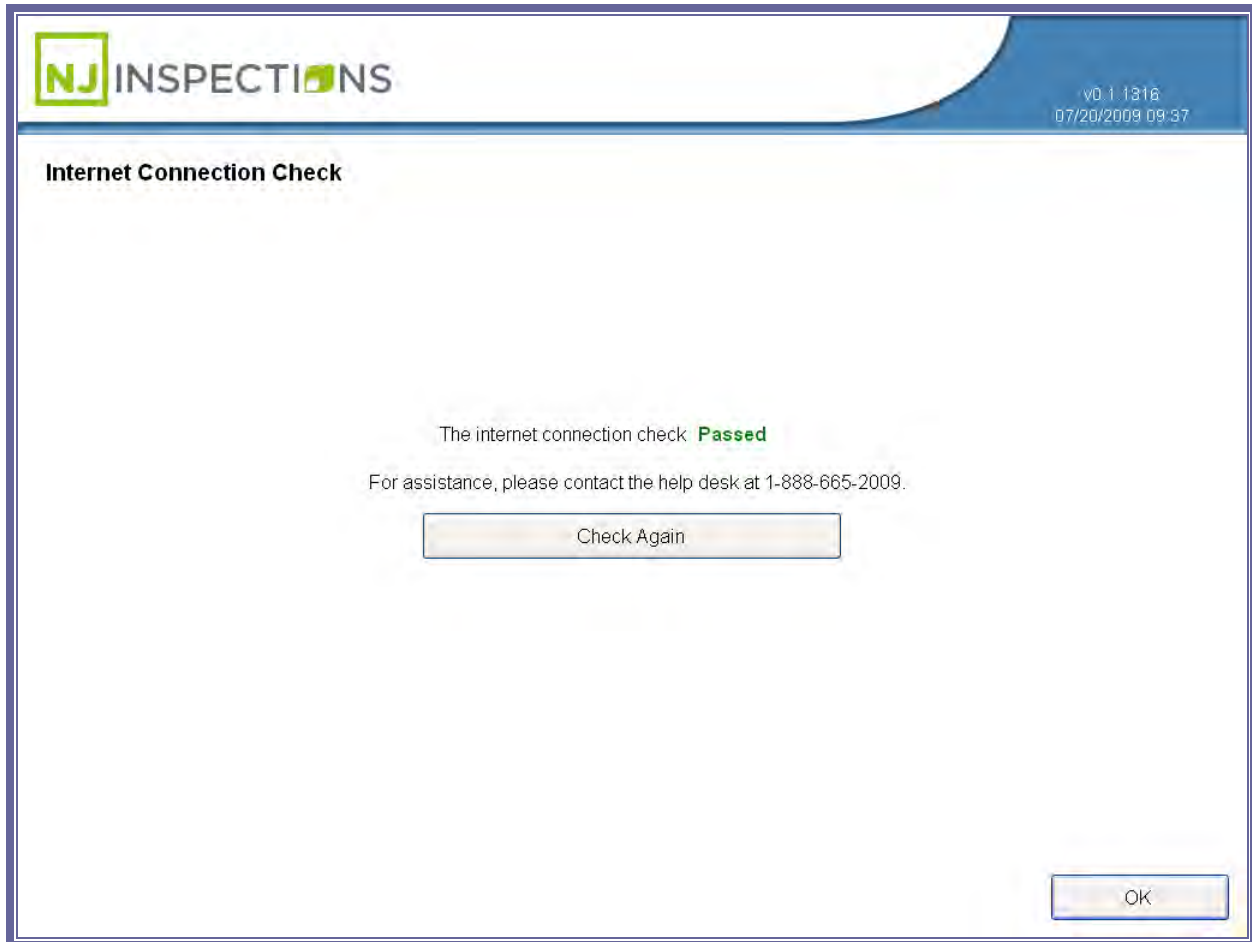

FIGURE 9-9: INTERNET CONNECTION CHECK SCREEN

NEW JERSEY OPERATORS INSTRUCTION MANUAL

THE WORKSTATION MANAGEMENT MENU (7)

(7) INITIALIZATION

- See Figure 9-10 to Figure 9-12 for steps to initialize workstation.
 - a. Scan Workstation ID.

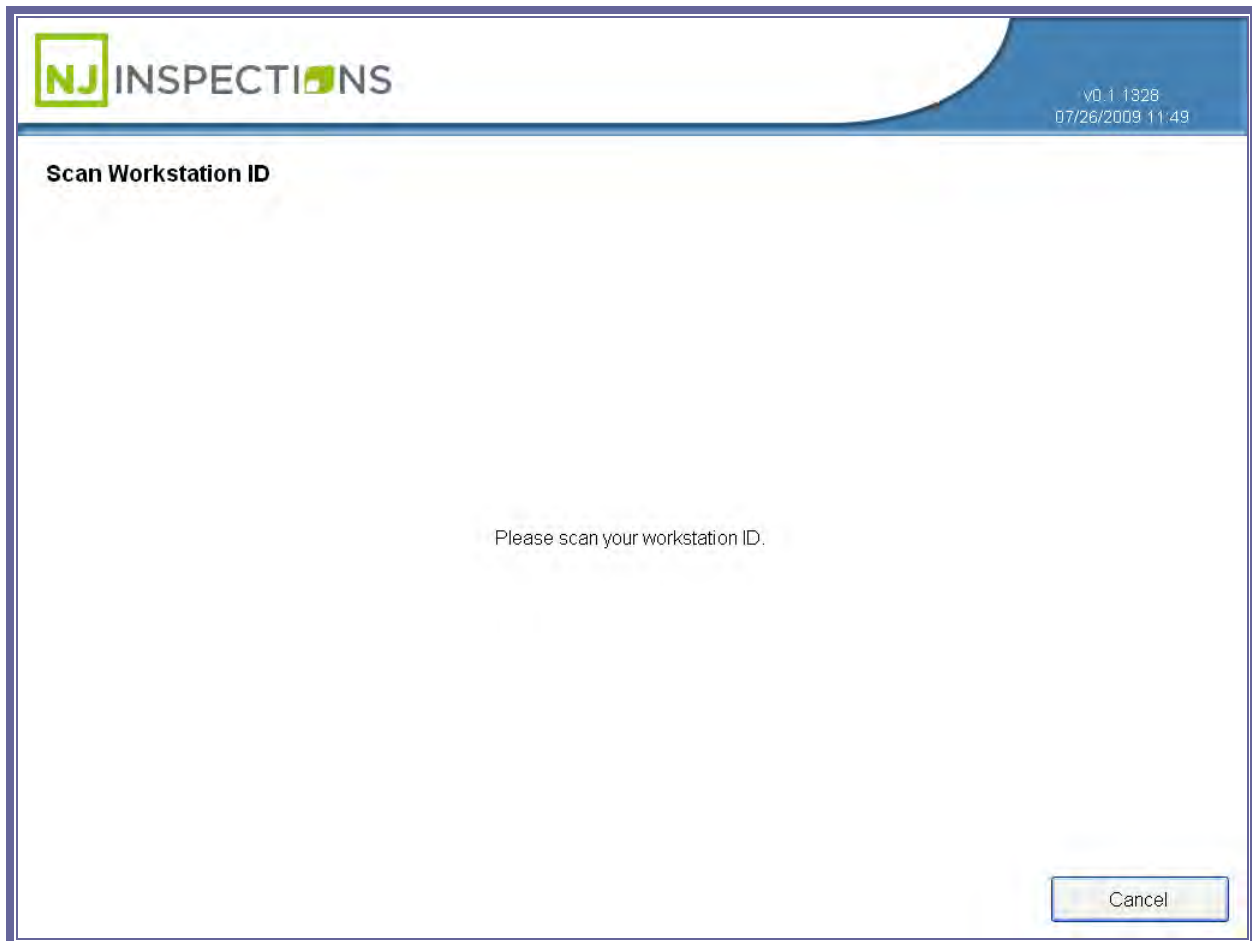

FIGURE 9-10: SCAN WORKSTATION ID SCREEN

NEW JERSEY OPERATORS INSTRUCTION MANUAL

THE WORKSTATION MANAGEMENT MENU (7)

b. Scan Facility ID.

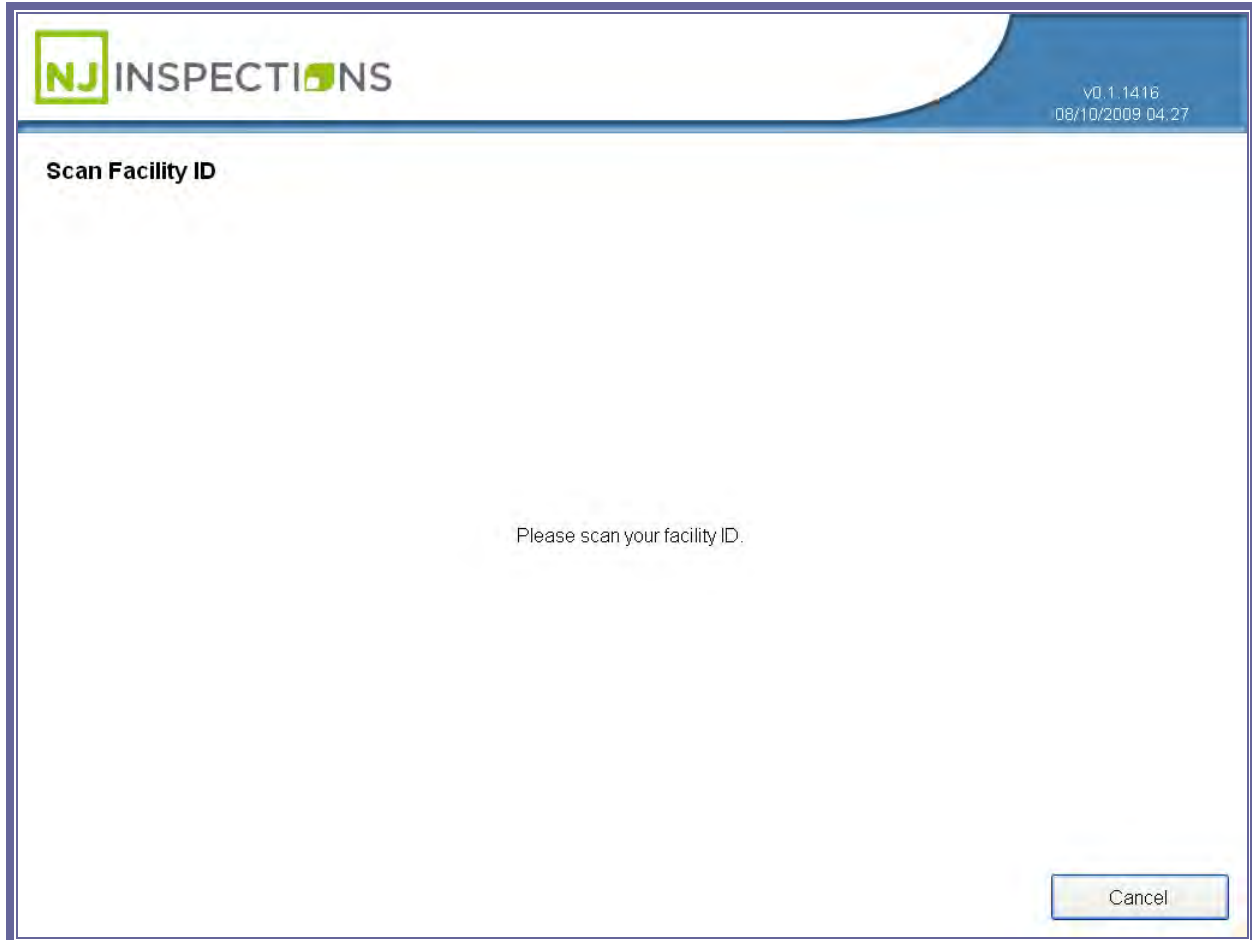

FIGURE 9-11: SCAN FACILITY ID SCREEN

NEW JERSEY OPERATORS INSTRUCTION MANUAL

THE WORKSTATION MANAGEMENT MENU (7)

c. View Facility Information.

NJ INSPECTIONS v0.1.1416
08/10/2008 04:29

Edit Facility Information

Facility name:

Address:

Address 2nd line:

City:

State:

Zip code:

Phone number:

Fax number:

Email address:

FIGURE 9-12: VIEW FACILITY INFORMATION SCREEN

NEW JERSEY OPERATORS INSTRUCTION MANUAL

THE WORKSTATION MANAGEMENT MENU (7)

(8) REPORTS MENU



FIGURE 9-13: REPORTS MENU

NEW JERSEY OPERATORS INSTRUCTION MANUAL

THE WORKSTATION MANAGEMENT MENU (7)

(9) VIEW FACILITY INFORMATION

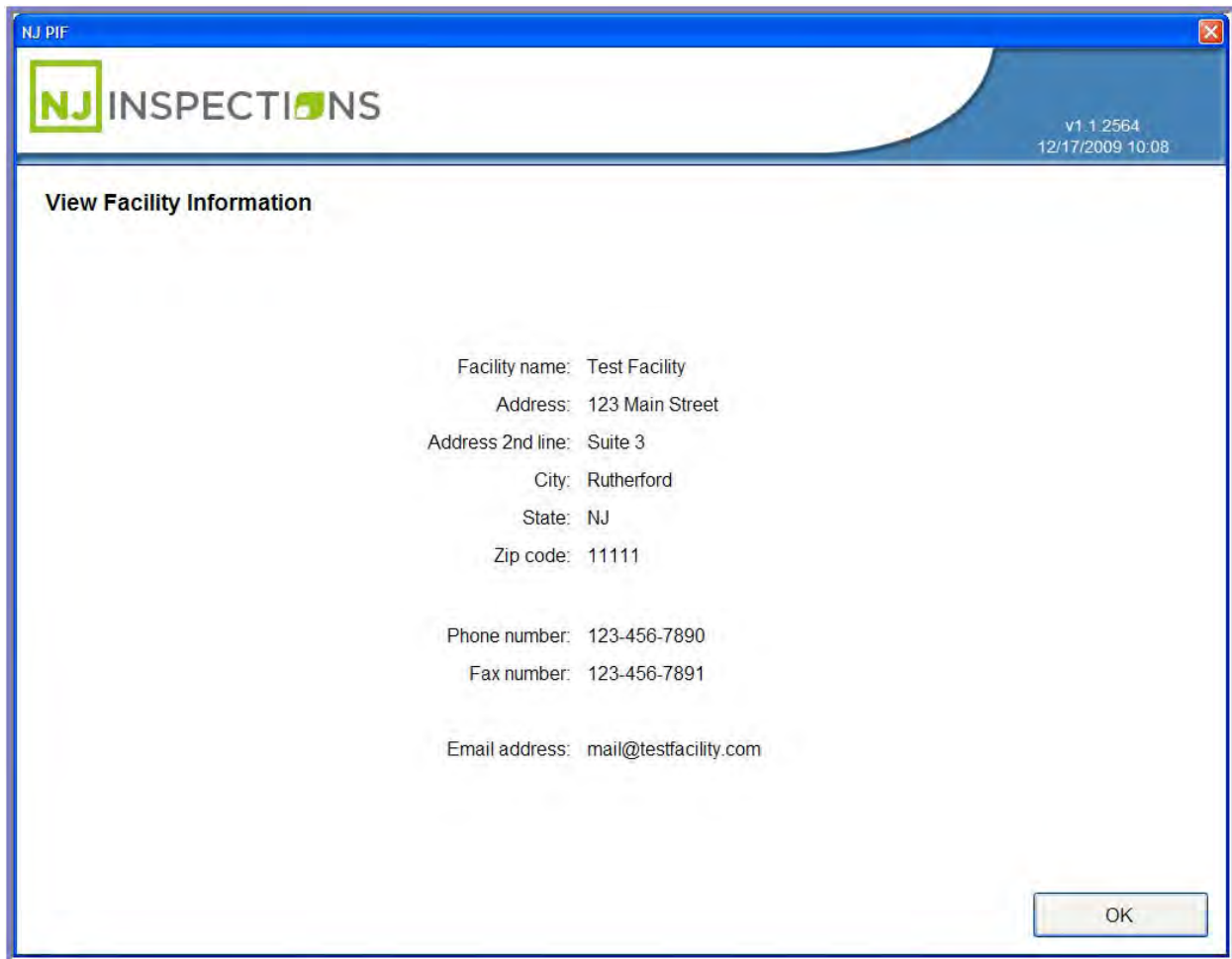
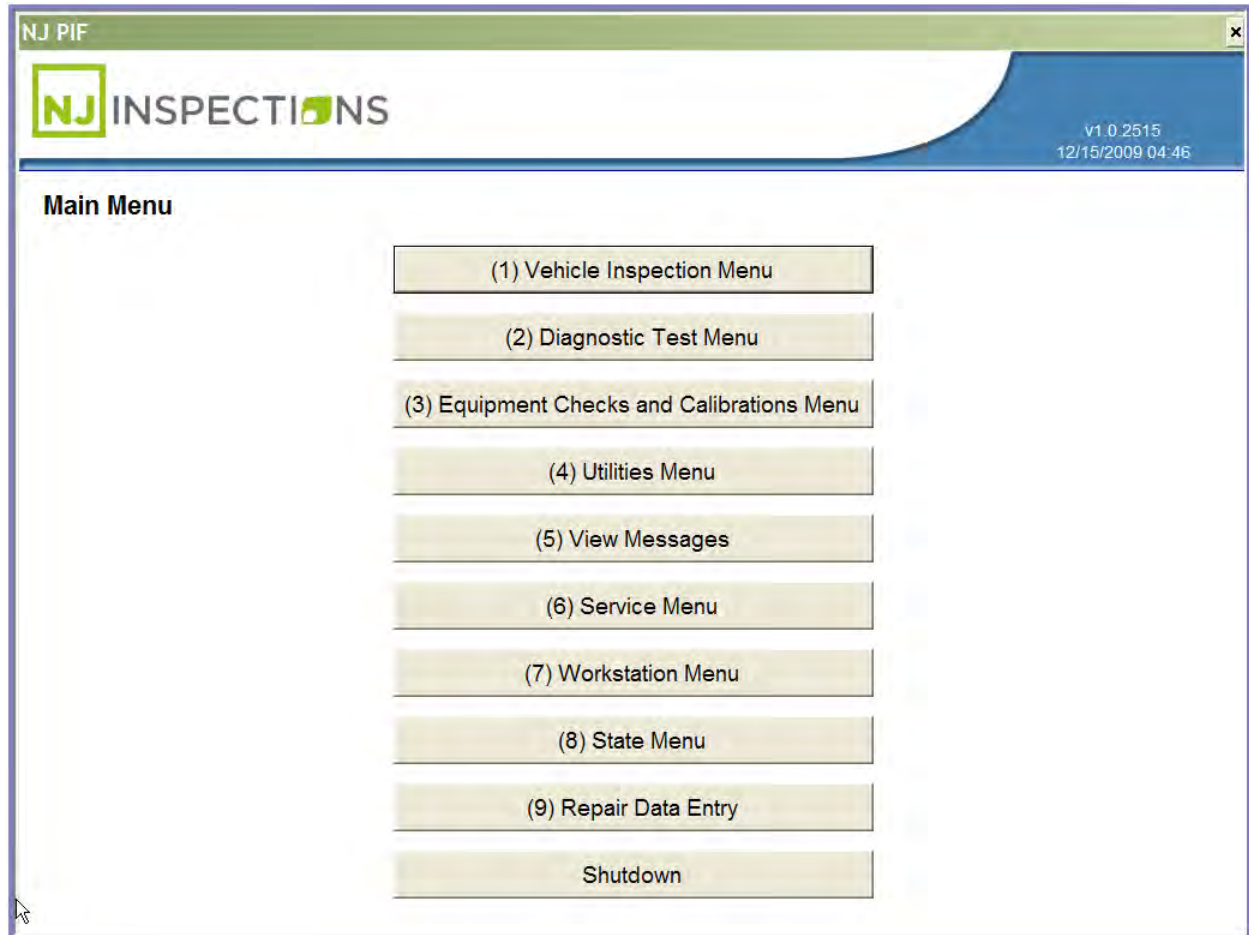

FIGURE 9-14: VIEW FACILITY INFORMATION SCREEN

Select option **(0) Main Menu** to return to the **Main Menu** from the **Workstation Management Menu**.



Chapter 10

Repair Data

Entry (9)

NEW JERSEY OPERATORS INSTRUCTION MANUAL

REPAIR DATA ENTRY (9)

CHAPTER 10: REPAIR DATA ENTRY

1. From the **Workstation Management Menu**, select option **(9) Repair Data Entry**.

Repair Data Entry is where the customer inputs any vehicle repair's they have performed.

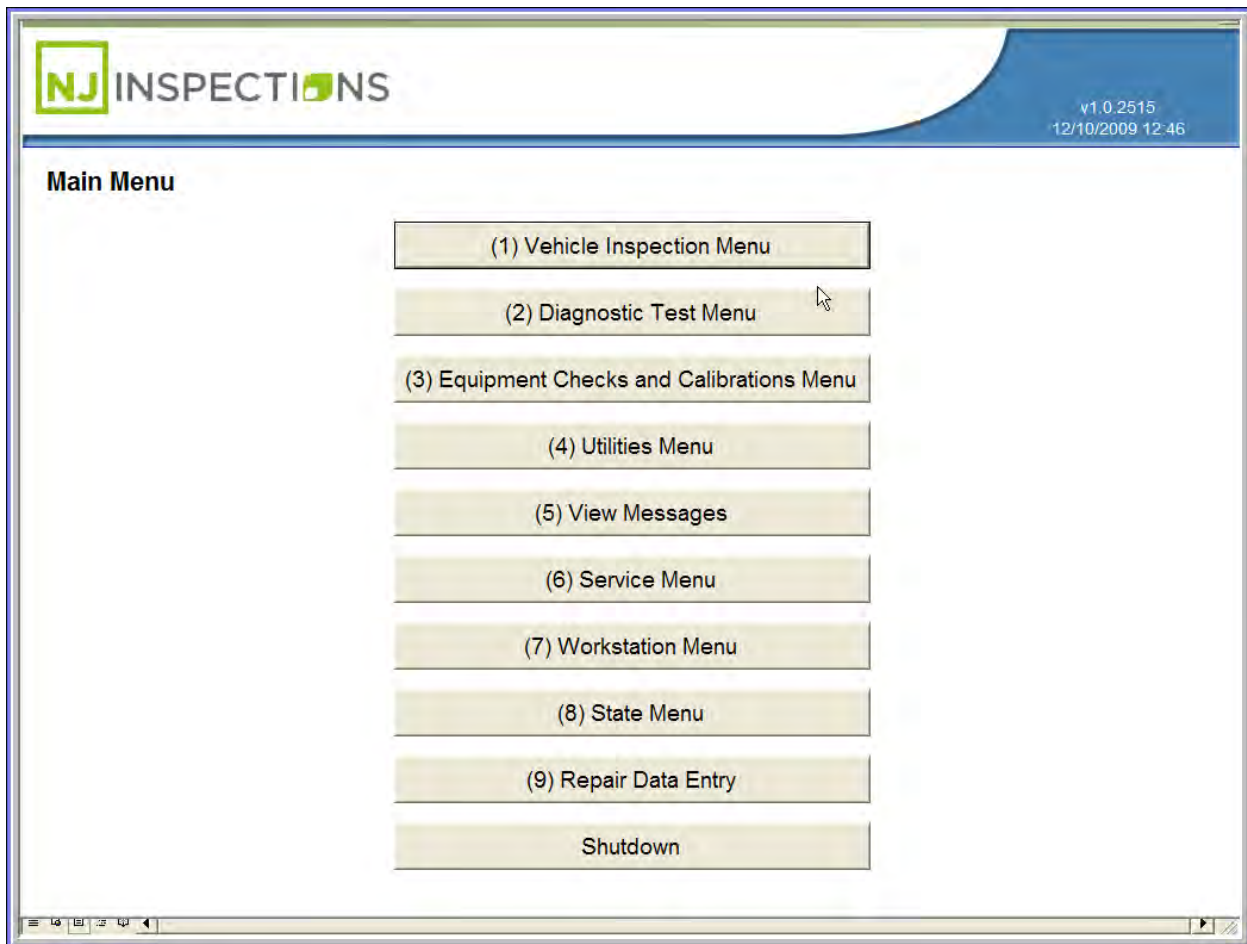

FIGURE 10-1: MAIN MENU SCREEN

NEW JERSEY OPERATORS INSTRUCTION MANUAL

REPAIR DATA ENTRY (9)

2. Enter your user name and password and click Login to enter the New Jersey Vehicle Inspection Portal.

NJ INSPECTIONS v1.0.2515
12/10/2009 12:51

ERF Repair Data Entry

STATE OF NEW JERSEY MOTOR VEHICLE COMMISSION **New Jersey Vehicle Inspection Portal Login**

December 10, 2009

Enter your user name and password to login.

User Name

Password

Login

[Forgot your ID or Password?](#)

One Portal! ID. So much Data At your Finger Tips...

Done

FIGURE 10-2: ERF REPAIR DATA ENTRY LOGIN SCREEN

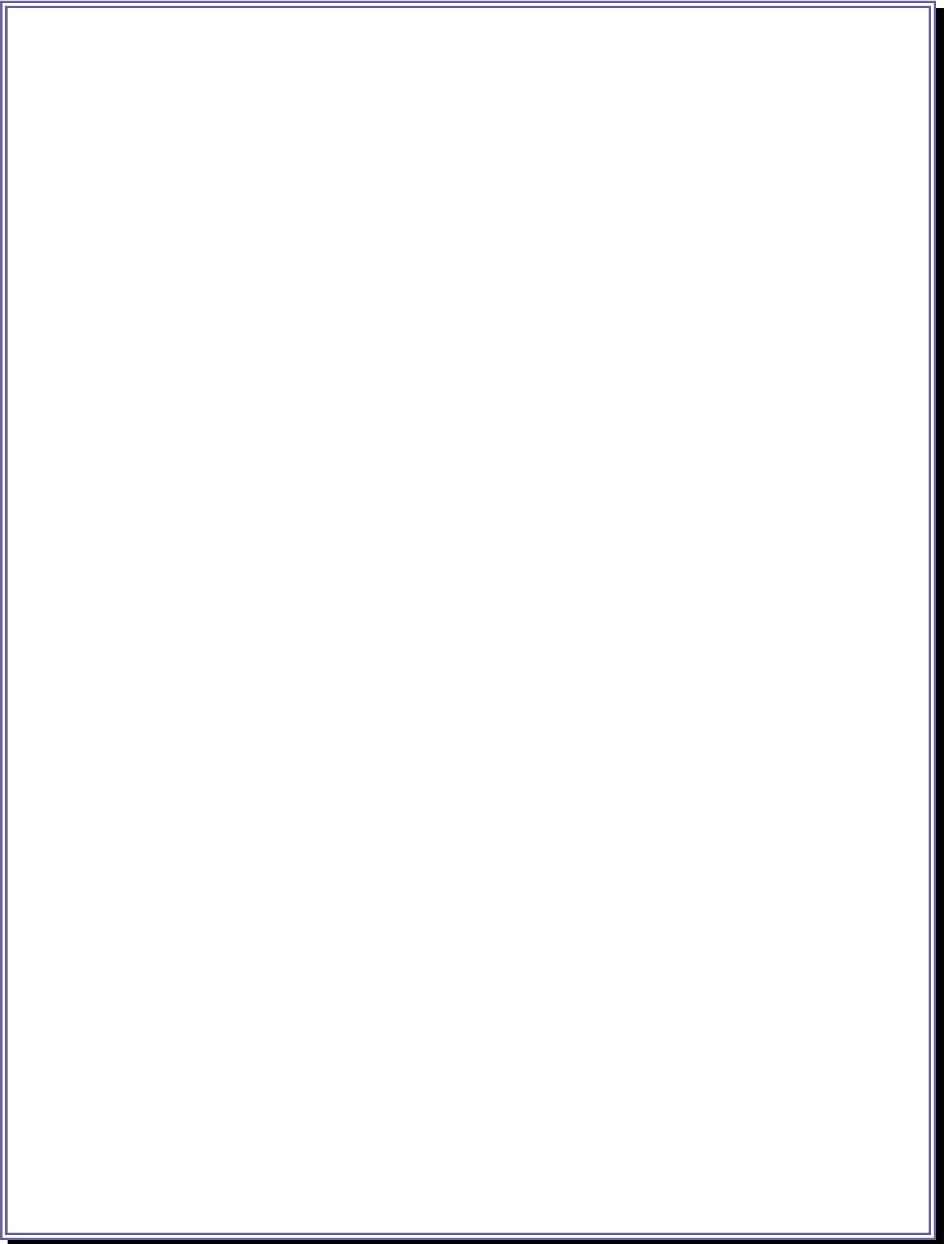

Chapter 11

Troubleshooting

NEW JERSEY OPERATORS INSTRUCTION MANUAL

TROUBLESHOOTING GUIDE (LCD MONITOR)

CHAPTER 11: TROUBLESHOOTING

VIEWSONIC 17" LCD MONITOR TROUBLESHOOTING PROCEDURES:

NO POWER

Make sure power button (or switch) is ON.

Make sure A/C power cord is securely connected to the LCD display.

Plug another electrical device (like a radio) into the power outlet to verify that the outlet is supplying proper voltage.

POWER IS ON BUT NO SCREEN IMAGE

Make sure the video cable supplied with the LCD display is tightly secured to the video output port on the back of the computer. If the other end of the video cable is not attached permanently to the LCD display, tightly secure it to the LCD display.

Adjust brightness and contrast.

If you are using a Macintosh older than G3, you need a Macintosh adapter.

WRONG OR ABNORMAL COLORS

If any colors (red, green, or blue) are missing, check the video cable to make sure it is securely connected. Loose or broken pins in the cable connector could cause an improper connection.

Connect the LCD display to another computer.

If you have an older graphics card, contact ViewSonic® for a non-DDC adapter.

CONTROL BUTTONS DO NOT WORK

NEW JERSEY OPERATORS INSTRUCTION MANUAL

TROUBLESHOOTING GUIDE (LCD MONITOR)

Press only one button at a time.

(Troubleshooting procedures courtesy of ViewSonic)

NEW JERSEY OPERATORS INSTRUCTION MANUAL

TROUBLESHOOTING GUIDE (BARCODE SCANNER)

HONEYWELL HHP 4600 BARCODE SCANNER TROUBLESHOOTING

PROCEDURES:

The Bar Code Scanner automatically performs self-tests whenever you turn it on.

If your Bar Code Scanner is not functioning properly, review the following Troubleshooting Guide to try to isolate the problem:

Is the power on?

Is the aiming beam on?

If the aiming beam is not illuminated, check to make sure that:

- The cable is connected properly.
- The host system power is on (if external power is not used).
- The trigger works.

Is the imager having trouble reading your symbols?

- If the imager isn't reading symbols well, check that the symbols:
 - Are not smeared, rough, scratched, or exhibiting voids,
 - Are not coated with frost or water droplets on the surface, or
 - Are enabled in the imager or in the decoder to which the imager connects.

If the connections and power supply are Ok, please call the NJ2009 Help Desk for assistance @ 1-888-6NJ-2009 or (888-665-2009).

If the Bar Code Scanner won't read your bar code at all.

Call the NJ2009 Help Desk for assistance @ 1-888-6NJ-2009 or (1-888-665-2009).

NEW JERSEY OPERATORS INSTRUCTION MANUAL

TROUBLESHOOTING GUIDE (BARCODE SCANNER)

RESET THE BAR CODE SCANNER SETTINGS



CAUTION:

Do not attempt to reset or reprogram your Bar Code Scanner. If you are having difficulty with your bar code scanner, call the NJ2009 Help Desk at 1-888-6NJ-2009 or (1-8888-665-2009) for assistance.

- In the event that the NJ2009 Help Desk Customer Service Agent determines that your bar code scanner requires reprogramming, you will be instructed to scan the Default bar code below.
- **DO NOT SCAN THIS BAR CODE UNLESS INSTRUCTED TO DO SO...**

Default



(Troubleshooting procedures courtesy of Honeywell and SGS Testcom Inc.)

NEW JERSEY OPERATORS INSTRUCTION MANUAL

TROUBLESHOOTING GUIDE (GAS CAP)

WAEKON FPT27 GAS CAP TESTER TROUBLESHOOTING PROCEDURES:

Use the flow chart to assist with troubleshooting inconsistent fuel cap testing.

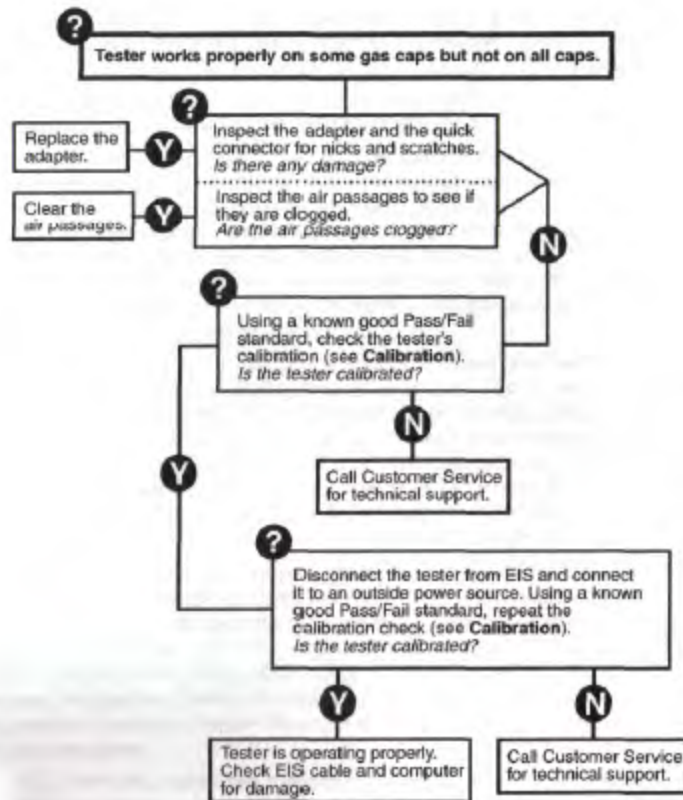

(Troubleshooting procedures courtesy of Waekon)

[TABLE OF CONTENTS](#)

Printer Jams

Troubleshooting

Procedures

NEW JERSEY OPERATORS INSTRUCTION MANUAL

TROUBLESHOOTING GUIDE (PRINTER JAM)

PRINTER JAMS

- Accessing jammed areas
- Understanding jam lights and access locations
- Clearing jams behind the photo conductor kit and toner cartridge
- Clearing jams from the standard exit bin
- Clearing jams from tray 1
- Clearing jams from tray 2
- Clearing jams in the manual feeder
- Clearing jams behind the rear door

NEW JERSEY OPERATORS INSTRUCTION MANUAL

TROUBLESHOOTING GUIDE (PRINTER JAM)

Accessing jam areas

Open doors and remove trays to access jam areas. The following illustration shows possible jam areas:

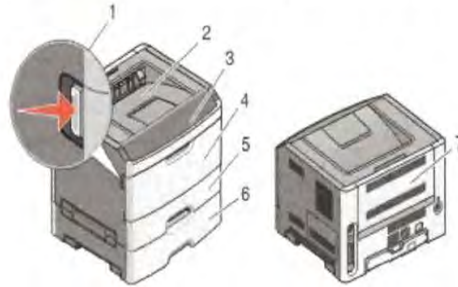

Access point	Description
1	Push button to open the front door. Inside this door is the unit housing the toner cartridge and photoconductor kit.
2	Standard exit bin
3	Front door
4	Manual feeder door
5	Standard 250-sheet tray (Tray 1)
6	Optional tray (Tray 2)
7	Rear door

Understanding jam lights and access locations

The following table lists the jam lights and messages and provides brief instructions for how to access each jam. More detailed instructions follow.

Note: The jam messages listed appear on the virtual display of the Embedded Web Server.

200.yy Paper jam



200.yy Paper jam

! - On

NEW JERSEY OPERATORS INSTRUCTION MANUAL

TROUBLESHOOTING GUIDE (PRINTER JAM)

! - On

|> - On

Try one of the following:

- Remove Tray 1.
- Open the front door, and then remove the photoconductor kit and toner cartridge unit.

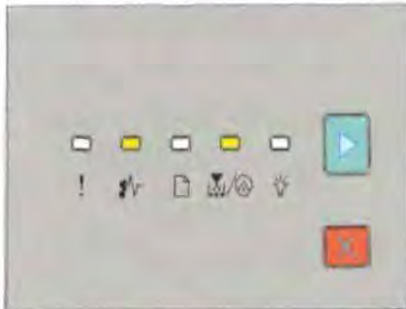

201.yy Paper jam

!r - On

!r/c - On

|> - On

Open the front door, and then remove the photoconductor kit and toner cartridge unit.



202.yy Paper jam

!r - On

! - On

|> - On

Open the front door, and then open the rear door.

NEW JERSEY OPERATORS INSTRUCTION MANUAL

TROUBLESHOOTING GUIDE (PRINTER JAM)



231.yy Paper jam

! - On

! - Blinking

! - On

Open the front door, and then open the rear door.



233.yy Paper jam

! - On

! - Blinking

! - Blinking

! - On

Try one of the following:

- Remove Tray 1, and then depress the lever.
- Open the front door, and then open the rear door.



234.yy Paper jam

NEW JERSEY OPERATORS INSTRUCTION MANUAL

TROUBLESHOOTING GUIDE (PRINTER JAM)

! - On

⚡ - Blinking

▶ - On

Try one of the following:

- Open the front door, and then open the rear door.
- Remove Tray 1, and then depress the lever.



235.yy Paper jam

! - On

⚡ - Blinking

⚡ - Blinking

▶ - On

Remove the jam from the standard exit bin.



24x.yy Paper jam

! - On

⚡ - On

⚡/⚡ - On

▶ - On

Try one of the following:

- Remove Tray 1.
- Open the front door, and then remove the photoconductor kit and toner cartridge unit.
- Remove Tray 2.

NEW JERSEY OPERATORS INSTRUCTION MANUAL

TROUBLESHOOTING GUIDE (PRINTER JAM)



251.yy Paper jam

! - On

! - On

! - On

! - On

Remove the jam from the manual feeder.

Clearing jams behind the photoconductor kit and toner cartridge

1 Push the release button, and then lower the front door.

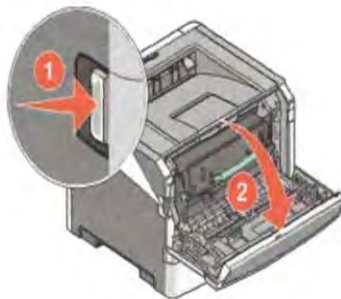

NEW JERSEY OPERATORS INSTRUCTION MANUAL

TROUBLESHOOTING GUIDE (PRINTER JAM)

- 2 Lift and pull the unit containing the photoconductor kit and the toner cartridge out of the printer. Set the unit aside on a flat, clean surface.

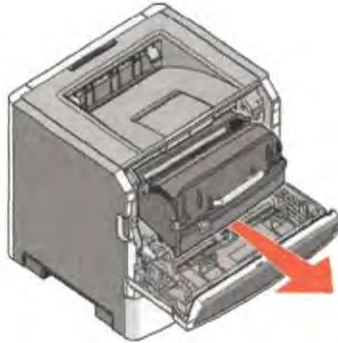

Warning—Potential Damage: Do not touch the photoconductor on the underside of the photoconductor kit. Use the cartridge handle whenever you are holding the cartridge.

CAUTION—HOT SURFACE: The fuser and the inside of the printer near the fuser may be hot. To reduce the risk of injury from a hot component, allow the surface to cool before removing paper from this area.

- 3 Remove the jammed paper.

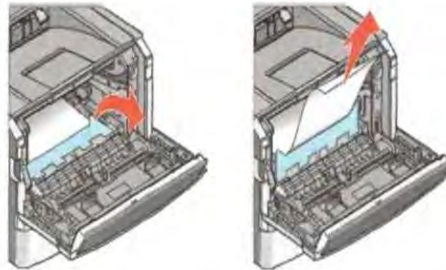

Note: If the paper is not easy to remove, then open the rear door to remove the paper.

- 4 Align and reinstall the unit.



NEW JERSEY OPERATORS INSTRUCTION MANUAL

TROUBLESHOOTING GUIDE (PRINTER JAM)

- 5 Close the front door.
- 6 Press  to continue printing.

Clearing jams from the standard exit bin

A duplex print job was sent to the printer using a paper size not supported for duplex printing. A sheet is jammed in the standard exit bin.

To remove the jam, gently pull the sheet straight out of the standard exit bin.



Clearing jams from Tray 1

To see whether paper is jammed in or behind Tray 1, the standard tray:

- 1 Remove Tray 1.

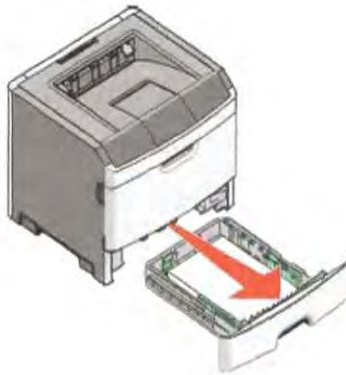

NEW JERSEY OPERATORS INSTRUCTION MANUAL

TROUBLESHOOTING GUIDE (PRINTER JAM)

2 Remove the jammed paper.

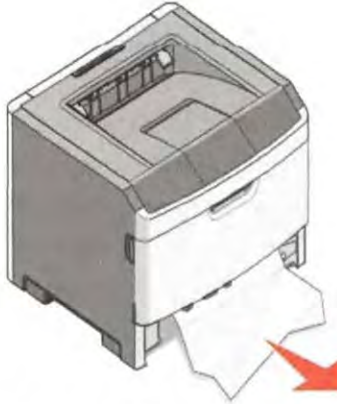

3 If necessary, depress the lever to free the paper and remove the jam.

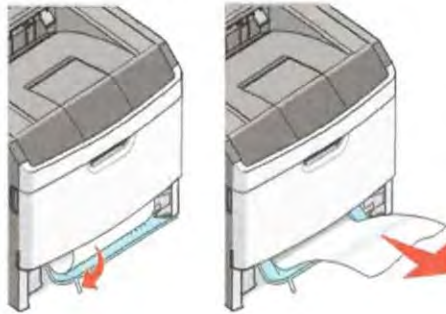

4 Insert the tray.



5 Press  to continue printing.

NEW JERSEY OPERATORS INSTRUCTION MANUAL

TROUBLESHOOTING GUIDE (PRINTER JAM)

Clearing jams from Tray 2

To see whether paper is jammed in or behind Tray 2:

- 1 Remove Tray 2.

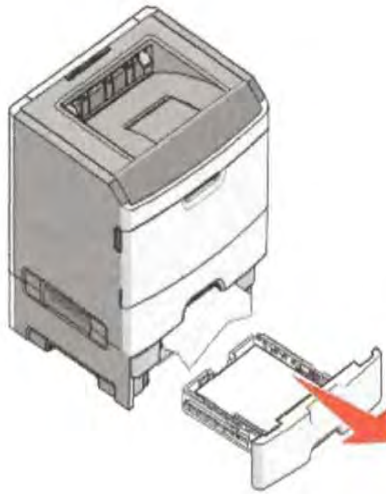

- 2 Remove the jammed paper.



NEW JERSEY OPERATORS INSTRUCTION MANUAL

TROUBLESHOOTING GUIDE (PRINTER JAM)

3 Insert the tray.



4 Press  to continue printing.

Clearing jams in the manual feeder

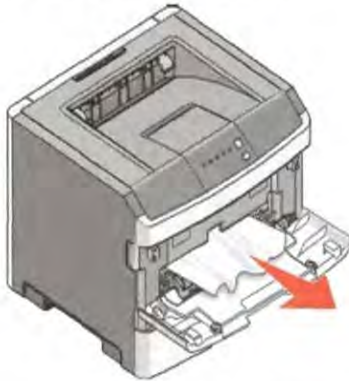

Paper jammed in the manual feeder can usually be grasped and pulled straight out. If the jam cannot be removed this way, check for jammed paper behind the photoconductor kit and toner cartridge unit. For more information, see "Clearing jams behind the photoconductor kit and toner cartridge" on page 118.

NEW JERSEY OPERATORS INSTRUCTION MANUAL

TROUBLESHOOTING GUIDE (PRINTER JAM)

Clearing jams behind the rear door

If the paper is exiting the printer, pull the paper out. If the paper is not exiting the printer:

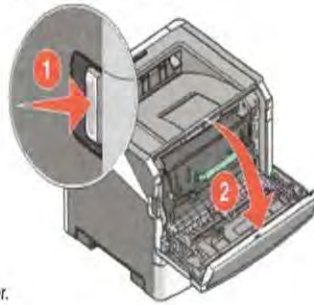

1 Push the release button, and then lower the front door.

2 Pull open the rear door.

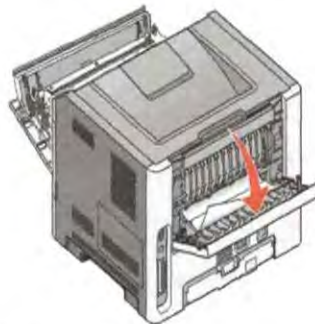

The paper may be jammed with one end caught in the exit bin.



NEW JERSEY OPERATORS INSTRUCTION MANUAL

TROUBLESHOOTING GUIDE (PRINTER JAM)

3 Remove the jammed paper.

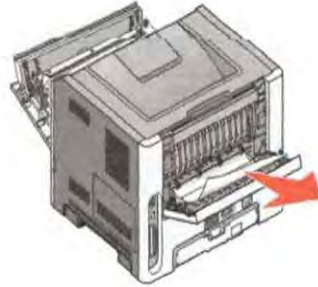

4 Close both the front and rear doors.

5 Press  to continue printing.

[TABLE OF CONTENTS](#)

Basic Printer Troubleshooting Procedures

NEW JERSEY OPERATORS INSTRUCTION MANUAL

TROUBLESHOOTING GUIDE (BASIC PRINTER ISSUES)

BASIC PRINTER TROUBLESHOOTING PROCEDURES

- Solving basic printer problems
- Solving printing problems
- Solving option problems
- Solving paper feed problems
- Solving print quality problems
- Clearing jams

NEW JERSEY OPERATORS INSTRUCTION MANUAL

TROUBLESHOOTING GUIDE (BASIC PRINTER ISSUES)

Troubleshooting

Solving basic printer problems

If there are basic printer problems, or the printer is unresponsive, make sure:

- The power cord is plugged into the printer and a properly grounded electrical outlet.
- The electrical outlet is not turned off by any switch or breaker.
- The *Ground Fault Circuit Interrupter (GFCI)* has not tripped.
- The printer is not plugged into any surge protectors, uninterruptible power supplies, or extension cords.
- Other electronic equipment plugged into the outlet is working.
- The printer is turned on. Check the printer power switch.
- The printer cable is securely attached to the printer and the host computer, print server, option, or other network device.
- All options are properly installed.
- The printer driver settings are correct.

Once you have checked each of these possibilities, turn the printer off, wait for about 10 seconds, and then turn the printer back on. This often fixes the problem.

Solving printing problems

Jobs do not print

These are possible solutions. Try one or more of the following:

MAKE SURE THE PRINTER IS READY TO PRINT

Make sure the  light is on before sending a job to print.

CHECK TO SEE IF THE STANDARD EXIT BIN IS FULL

Remove the stack of paper from the standard exit bin.

CHECK TO SEE IF THE TRAY IS EMPTY

Load paper in the tray.

MAKE SURE THE CORRECT PRINTER SOFTWARE IS INSTALLED

Verify that you installed the correct printer software for your printer model.

Click **Install printer and software** on the *Software and Documentation* CD to check which software is installed. Make sure the model number of the software matches the model number of your printer.

To verify that the printer software is the most current, check the Lexmark Web site at www.lexmark.com.

NEW JERSEY OPERATORS INSTRUCTION MANUAL

TROUBLESHOOTING GUIDE (BASIC PRINTER ISSUES)

MAKE SURE THE PRINTER IS CONNECTED TO THE NETWORK

Print a network setup page and check that the status shows **Connected**. If the status is **Not Connected**, check the network cables, and then try printing the network setup page again. Contact your system support person to make sure the network is functioning correctly.

Copies of the printer software are also available on the Lexmark Web site at www.lexmark.com.

MAKE SURE YOU ARE USING A RECOMMENDED USB, PARALLEL, OR ETHERNET CABLE

For more information, visit the Lexmark Web site at www.lexmark.com.

MAKE SURE PRINTER CABLES ARE SECURELY CONNECTED

Check the cable connections to the printer to make sure they are secure. For more information, see the setup documentation that came with the printer.

Multiple-language PDFs do not print

The documents contain unavailable fonts.

- 1 Open the document you want to print in Adobe Acrobat.
- 2 Click the printer icon.
The Print dialog appears.
- 3 Select **Print as image**.
- 4 Click **OK**.

Job takes longer than expected to print

The job is too complex.

Reduce the complexity of your print job by eliminating the number and size of fonts, the number and complexity of images, and the number of pages in the job.

Job prints from the wrong tray or on the wrong paper

These are possible solutions. Try one or more of the following:

CHECK THE PAPER SIZE AND PAPER TYPE SETTINGS

From the Paper menu, make sure the Paper Size and Paper Type settings match the paper loaded in the trays. To access the Paper menu, do one of the following:

- If the printer is on a network, access the Embedded Web Server by typing the IP address of the printer in the address bar of a Web browser. From the Settings tab, click **Paper Menu**.
- If the printer is connected to a computer by a USB or parallel cable, open the Local Printer Settings Utility for Windows or Printer Settings for Macintosh. One of these utilities installs with the printer software.

NEW JERSEY OPERATORS INSTRUCTION MANUAL

TROUBLESHOOTING GUIDE (BASIC PRINTER ISSUES)

CHECK THE PAPER TAB SETTINGS IN YOUR OPERATING SYSTEM

Open Print Properties in a Windows operating system or the print dialog in a Macintosh operating system. Make sure the input options settings for Paper size, Paper tray, and Paper type correspond with the paper loaded in the tray.

Incorrect characters print



Make sure the printer is not in Hex Trace mode. If the "Hex Trace mode" light sequence appears, you must exit Hex Trace mode before you can print your job. To exit Hex Trace mode, turn the printer off and back on.

Tray linking does not work

Make sure to do all of the following:

- Load both Tray 1 and Tray 2 with the same paper size and type.
- From Print Properties or the print dialog, change the Paper source to Automatically select.

Large jobs do not collate

These are possible solutions. Try one or more of the following:

CHECK THE COLLATE SETTING

From the Finishing menu, make sure Collate is On. To access the Finishing menu, do one of the following:

- If the printer is on a network, access the Embedded Web Server by typing the printer IP address into the address field of your Web browser. From the Settings screen, click **Finishing Menu**.
- If the printer is connected to a computer by a USB or parallel cable, open the Local Printer Settings Utility for Windows or Printer Settings for Macintosh. One of these utilities installs with the printer software.

CHECK THE PAPER TAB SETTINGS IN YOUR OPERATING SYSTEM

Open Print Properties in a Windows operating system or the print dialog in a Macintosh operating system. Make sure the "Page layout" setting for "Collate copies" is On, or the Collate check box is selected.

Note: Clearing the Collate check box overrides the setting in the Finishing menu.

NEW JERSEY OPERATORS INSTRUCTION MANUAL

TROUBLESHOOTING GUIDE (BASIC PRINTER ISSUES)

REDUCE THE COMPLEXITY OF THE PRINT JOB

Reduce the complexity of the print job by eliminating the number and size of fonts, the number and complexity of images, and the number of pages in the job.

MAKE SURE THE PRINTER HAS ENOUGH MEMORY

Add printer memory.

Solving option problems

Option does not operate correctly or quits after it is installed

These are possible solutions. Try one or more of the following:

RESET THE PRINTER

Turn the printer off, wait for about 10 seconds, and then turn the printer on.

CHECK TO SEE IF THE OPTION IS CONNECTED TO THE PRINTER

- 1 Turn the printer off.
- 2 Unplug the printer.
- 3 Check the connection between the option and the printer.

MAKE SURE THE OPTION IS INSTALLED

Print a menu settings page and check to see if the option is listed in the Installed Options list. If the option is not listed, reinstall it.

MAKE SURE THE OPTION IS SELECTED

From the program you are using, select the option. Mac OS 9 users should make sure the printer is set up in the Chooser.

Drawers

These are possible solutions. Try one or more of the following:

MAKE SURE THE PAPER IS LOADED CORRECTLY

- 1 Pull the tray completely out.
- 2 Check for paper jams or misfeeds.
- 3 Make sure the guides are aligned against the edges of the paper.
- 4 Insert the tray.

NEW JERSEY OPERATORS INSTRUCTION MANUAL

TROUBLESHOOTING GUIDE (BASIC PRINTER ISSUES)

RESET THE PRINTER

Turn the printer off, wait about 10 seconds, and then turn the printer on.

Memory card

Make sure the memory card is securely connected to the printer system board.

Solving paper feed problems

Paper frequently jams

These are possible solutions. Try one or more of the following:

CHECK THE PAPER

Use recommended paper or specialty media. For more information, see "Paper and specialty media guide" on page 51.

FLEX, FAN, AND STRAIGHTEN THE PAPER BEFORE LOADING IT IN THE TRAY



MAKE SURE THERE IS NOT TOO MUCH PAPER IN THE TRAY

Make sure the stack of paper you load does not exceed the maximum stack height indicated in the tray.

CHECK THE GUIDES

Move the guides in the tray to the correct positions for the paper size loaded.

THE PAPER MAY HAVE ABSORBED MOISTURE DUE TO HIGH HUMIDITY

- Load paper from a fresh package.
- Store paper in its original wrapper until you use it.

Paper jam lights remain on after jam is cleared

The paper path is not clear. Clear jammed paper from the entire paper path, and then close any open doors.

NEW JERSEY OPERATORS INSTRUCTION MANUAL

TROUBLESHOOTING GUIDE (BASIC PRINTER ISSUES)

Page that jammed does not reprint after the jam is cleared

Jam Recovery is set to Off. Do one of the following to set Jam Recovery to Auto or On:

- If the printer is on a network, access the Embedded Web Server:
 - 1 Type the printer IP address into the address field of your Web browser.



Note: If you do not know the IP address of the printer, print a network setup page and locate the IP address in the TCP/IP section.
 - 2 From the Settings tab, make sure Jam Recovery is set to Auto or On, and then click **Submit**.
- If the printer is connected to a computer by a USB or parallel cable, open the Local Printer Settings Utility for Windows or Printer Settings for Macintosh. One of these utilities installs with the printer software. From the Setup menu, make sure Jam Recovery is set to Auto or On.

Solving print quality problems

The information in the following topics may help you solve print quality problems. If these suggestions still do not correct the problem, call Customer Support. You may have a printer part that requires adjustment or replacement.

Isolating print quality problems

Print the print quality test pages to isolate print quality problems.

- 1 Turn the printer off, and then open the front door.
- 2 Press and hold  while turning the printer on.
- 3 Release .
- 4 Close the front door. The light sequence that represents the Home menu appears.





 - On

 /  - On

 - On

 - On

- 5 Press and release  until you see the light sequence for print quality test pages, as indicated on the printer settings configuration sheet.

- 6 Press and hold  until all lights cycle.

NEW JERSEY OPERATORS INSTRUCTION MANUAL

TROUBLESHOOTING GUIDE (BASIC PRINTER ISSUES)

After a few minutes, the print quality test pages print. The pages include:

- An information page containing information about the device, the cartridge, margin settings, and minimum stroke width, and a graphic for evaluating the print quality
 - Two pages for assessing how well the printer is capable of printing various types of graphics
- 7 Examine the pages to determine the quality of printing. If there are problems, see "Solving print quality problems" on page 131.
- To return to the Home menu, press and hold **[X]** until all the lights cycle. To exit the menus, turn the printer off.

Blank pages



Try one or more of the following:

- Remove and reinstall the toner cartridge.
- Remove and reinstall the photoconductor kit.

If the printer still prints blank pages, it may need to be serviced. For more information, contact Customer Support.

Characters have jagged or uneven edges



If you are using downloaded fonts, verify that the fonts are supported by the printer, the host computer, and the software program.

Clipped images

These are possible solutions. Try one or more of the following:

CHECK THE PAPER GUIDES

Move the guides in the tray to the correct positions for the paper size loaded.

CHECK THE PAPER SIZE SETTING

Make sure the Paper Size setting matches the paper loaded in the tray.

NEW JERSEY OPERATORS INSTRUCTION MANUAL

TROUBLESHOOTING GUIDE (BASIC PRINTER ISSUES)

Gray background



From the Quality menu, select a reduced Toner Darkness setting before sending the job to print. To access the Quality menu, do one of the following:

- If the printer is on a network, access the Embedded Web Server by typing the printer IP address into the address field of your Web browser. From the Settings tab, click **Print Settings**.
- If the printer is connected to a computer by a USB or parallel cable, open the Local Printer Settings Utility for Windows or Printer Settings for Macintosh. One of these utilities installs with the printer software.

Ghost images



These are possible solutions. Try one or more of the following:

THE PHOTOCONDUCTOR KIT MAY BE DEFECTIVE

Replace the photoconductor kit.

CHECK THE PAPER SIZE AND PAPER TYPE SETTINGS

From the Paper menu, change the paper size and paper type settings to match the paper loaded in the tray. To access the Paper menu, do one of the following:

- If the printer is on a network, access the Embedded Web Server by typing the printer IP address in the address field of your Web browser. From the Settings tab, click **Paper Menu**.
- If the printer is connected to a computer by a USB or parallel cable, open the Local Printer Settings Utility for Windows or Printer Settings for Macintosh. One of these utilities installs with the printer software.

NEW JERSEY OPERATORS INSTRUCTION MANUAL

TROUBLESHOOTING GUIDE (BASIC PRINTER ISSUES)

Incorrect margins

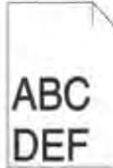

CHECK THE PAPER GUIDES

Move the guides in the tray to the correct positions for the paper size loaded.

CHECK THE PAPER SIZE SETTING

Make sure the Paper Size setting matches the paper loaded in the tray.

CHECK THE PAGE SIZE SETTING

Before sending the job to print, specify the correct page size in Print Properties or the software program.

Paper curl

These are possible solutions. Try one or more of the following:

CHECK THE PAPER TYPE SETTING

Make sure the Paper Type setting matches the paper loaded in the tray.

THE PAPER MAY HAVE ABSORBED MOISTURE DUE TO HIGH HUMIDITY

Try one or more of the following:

- Load paper from a fresh package.
- Store paper in its original wrapper until you use it.

Print is too dark

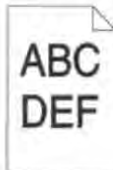

These are possible solutions. Try one or more of the following:

NEW JERSEY OPERATORS INSTRUCTION MANUAL

TROUBLESHOOTING GUIDE (BASIC PRINTER ISSUES)

CHECK THE DARKNESS, BRIGHTNESS, AND CONTRAST SETTINGS

The Toner Darkness setting is too dark, the Brightness setting is too dark, or the Contrast setting is too high.

- From Print Properties, change these settings.

Note: This solution applies to Windows users only.

- From the Quality menu, change these settings.

THE PAPER MAY HAVE ABSORBED MOISTURE DUE TO HIGH HUMIDITY

- Load paper from a fresh package.
- Store paper in its original wrapper until you use it.

CHECK THE PAPER

Avoid textured paper with rough finishes.

CHECK THE PAPER TYPE SETTING

Make sure the Paper Type setting matches the paper loaded in the tray.

THE TONER CARTRIDGE MAY BE DEFECTIVE

Replace the toner cartridge.

Print is too light



These are possible solutions. Try one or more of the following:

CHECK THE DARKNESS, BRIGHTNESS, AND CONTRAST SETTINGS

The Toner Darkness setting is too light, the Brightness setting is too light, or the Contrast setting is too low.

- From Print Properties, change these settings.

Note: This solution applies to Windows users only.

- From the Quality menu, change these settings.

THE PAPER MAY HAVE ABSORBED MOISTURE DUE TO HIGH HUMIDITY

- Load paper from a fresh package.
- Store paper in its original wrapper until you use it.

NEW JERSEY OPERATORS INSTRUCTION MANUAL

TROUBLESHOOTING GUIDE (BASIC PRINTER ISSUES)

CHECK THE PAPER

Avoid textured paper with rough finishes.

CHECK THE PAPER TYPE SETTING

Make sure the Paper Type setting matches the paper loaded in the tray.

THE TONER MAY BE LOW

When **Toner is low** appears on the virtual display, or when the print becomes faded, order a new toner cartridge.

THE TONER CARTRIDGE MAY BE DEFECTIVE

Replace the toner cartridge.

Skewed print

CHECK THE PAPER GUIDES

Move the guides in the tray to the correct positions for the paper size loaded.

CHECK THE PAPER

Make sure you are using paper that meets the printer specifications.

Toner fog or background shading appears on the page

These are possible solutions. Try one or more of the following:

THE TONER CARTRIDGE MAY BE DEFECTIVE

Replace the toner cartridge.

THERE IS TONER IN THE PAPER PATH

Contact Customer Support.

Toner rubs off



These are possible solutions. Try one or more of the following:

NEW JERSEY OPERATORS INSTRUCTION MANUAL

TROUBLESHOOTING GUIDE (BASIC PRINTER ISSUES)

CHECK THE PAPER TYPE SETTING

Make sure the Paper Type setting matches the paper loaded in the tray.

CHECK THE PAPER TEXTURE SETTING

Make sure the Paper Texture setting matches the paper loaded in the tray.

Toner specks



These are possible solutions. Try one or more of the following:

THE TONER CARTRIDGE MAY BE DEFECTIVE

Replace the toner cartridge.

THERE IS TONER IN THE PAPER PATH

Contact Customer Support.

Transparency print quality is poor

CHECK THE TRANSPARENCIES

Use only transparencies recommended by the printer manufacturer.

CHECK THE PAPER TYPE SETTING

Load transparencies, and make sure the Paper Type setting is set to Transparency.

Streaked horizontal lines



These are possible solutions. Try one or more of the following:

NEW JERSEY OPERATORS INSTRUCTION MANUAL

TROUBLESHOOTING GUIDE (BASIC PRINTER ISSUES)

THE TONER MAY SMEAR WHEN PAPER IS FED FROM A SPECIFIC SOURCE

From Print Properties, the print dialog, or the printer control panel, select another tray or feeder to feed the paper for the job.

THE TONER CARTRIDGE MAY BE DEFECTIVE

Replace the toner cartridge.

MAKE SURE THE PAPER PATH IS CLEAR

Paper could be caught between the photoconductor kit and the fuser. Check the paper path around the fuser area.

CAUTION—HOT SURFACE: The area of the printer near the fuser is hot. Allow the area to cool before removing paper from this area.

Clear any paper you see.

THERE MAY BE EXCESS TONER IN THE PAPER PATH

Contact Customer Support.

Streaked vertical lines



These are possible solutions. Try one or more of the following:

THE TONER MAY SMEAR WHEN PAPER IS FED FROM A SPECIFIC SOURCE

From Print Properties, the print dialog, or the printer control panel, select another tray or feeder to feed paper for the job.

THE TONER CARTRIDGE IS DEFECTIVE

Replace the toner cartridge.

MAKE SURE THE PAPER PATH IS CLEAR

Paper could be caught between the photoconductor kit and the fuser. Check the paper path around the fuser area.

Warning—Potential Damage: Do not touch the photoconductor on the underside of the photoconductor kit. Use the cartridge handle whenever you are holding the cartridge.

CAUTION—HOT SURFACE: The fuser and the inside of the printer near the fuser may be hot. To reduce the risk of injury from a hot component, allow the surface to cool before removing paper from this area.

NEW JERSEY OPERATORS INSTRUCTION MANUAL

TROUBLESHOOTING GUIDE (BASIC PRINTER ISSUES)

Clear any paper you see.

THERE MAY BE EXCESS TONER IN THE PAPER PATH

Contact Customer Support.

Solid black or white streaks appear on transparencies or paper



These are possible solutions. Try one or more of the following:

MAKE SURE THE FILL PATTERN IS CORRECT

If the fill pattern is incorrect, choose a different fill pattern from your software program.

CHECK THE PAPER TYPE

- Try a different type of paper.
- For transparencies, use only ones recommended by the printer manufacturer.
- Make sure the Paper Type setting matches what is loaded in the tray or feeder.
- Make sure the Paper Texture setting is correct for the type of paper or specialty media loaded in the tray or feeder.

MAKE SURE THE TONER IS DISTRIBUTED EVENLY IN THE TONER CARTRIDGE

Remove the toner cartridge and shake it from side to side to redistribute the toner to extend the life of the cartridge, and then reinstall it.

THE TONER CARTRIDGE MAY BE DEFECTIVE OR LOW ON TONER

Replace the used toner cartridge with a new one.

Contacting Customer Support

When you call Customer Support, describe the problem you are experiencing, the message on the display, and the troubleshooting steps you have already taken to find a solution.

You need to know your printer model type and serial number. For more information, see the label on the inside top front cover of the printer. The serial number is also listed on the menu settings page.

In the U.S. or Canada, call (1-800-539-6275). For other countries/regions, visit the Lexmark Web site at www.lexmark.com.

NEW JERSEY OPERATORS INSTRUCTION MANUAL

TROUBLESHOOTING GUIDE (BASIC PRINTER ISSUES)

Clearing jams

Avoiding jams

The following hints can help you avoid jams:

- Use only recommended paper or specialty media. For more information, see "Paper and specialty media guide" on page 51.
- Do not load too much paper. Make sure the stack height does not exceed the indicated maximum height.
- Do not load wrinkled, creased, damp, or curled paper.
- Flex, fan, and straighten paper before loading it.



- Do not use paper that has been cut or trimmed by hand.
- Do not mix paper sizes, weights, or types in the same stack.
- Store the paper in an appropriate environment.
- Do not remove trays while the printer is printing. Wait for the light to come on before removing a tray. The light sequence for loading paper also signals that the tray may be removed.



Load paper

- On

- Do not load the manual feeder while the printer is printing. Wait for the light to come on.
- Push all trays in firmly after loading paper.
- Make sure the guides in the trays are properly positioned, and are not pressing too tightly against the paper.
- Make sure all paper sizes and paper types are set correctly.
- Make sure all printer cables are attached correctly. For more information, see the setup documentation.

(Troubleshooting procedures courtesy of Lexmark)

NEW JERSEY
OPERATORS INSTRUCTION MANUAL

TROUBLESHOOTING GUIDE (OBDII INTERFACE MODULE)

[TABLE OF CONTENTS](#)

OBDII Interface Module Troubleshooting procedures

NEW JERSEY OPERATORS INSTRUCTION MANUAL

TROUBLESHOOTING GUIDE (OBDII INTERFACE MODULE)

OBDII INTERFACE MODULE TROUBLESHOOTING PROCEDURES:

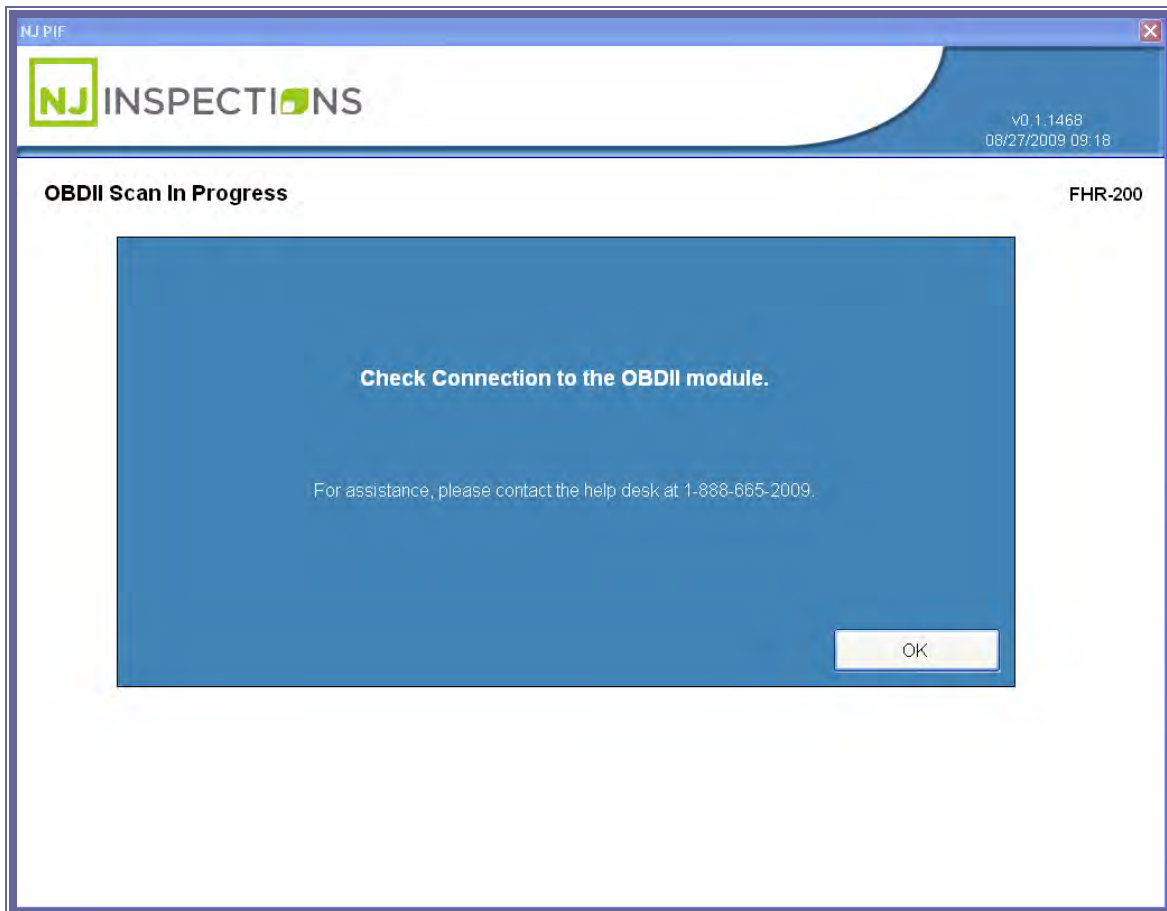

FIGURE 11-1: OBDII SCAN IN PROGRESS SCREEN

1. If you receive a connection error when testing a vehicle in the inspection menu please do the following:
 - a. Verify that Data Link Connector (DLC) cable is not damaged. If it is please call the help desk to an appointment for a replacement. If the cable does not appear to be damaged proceed to step b.

NEW JERSEY OPERATORS INSTRUCTION MANUAL

TROUBLESHOOTING GUIDE (OBDII INTERFACE MODULE)

- b. Please recycle the power to the OBDII interface module by unplugging and the plugging in the power supply into the power strip. Then try to attempt OBDII communications again with the vehicle. If it still does communicate call the help desk to schedule an appointment for service. It is possible you have a defective OBDII interface module.

Chapter 12

Equipment

Maintenance

NEW JERSEY OPERATORS INSTRUCTION MANUAL

EQUIPMENT MAINTENANCE

CHAPTER 12: EQUIPMENT MAINTENANCE

The following maintenance must be performed by the PIF:

- Check Low and High Cal gas bottles and ensure that the values are within allowable tolerance and the date has not expired
- Check cal gas bottle pressure if available
- Check the Zero bottle if available
- Check keyboard to ensure that all keys are functioning
- Check time and date
- Change Primary, and all In-lines filters if sample system is available
- Replace or clean any needed tubing
- Perform diagnostic checks on sample system
- Check printer drum and printer for cleanliness; clean or replace as needed
- Perform printer self-cleaning operation, if supported
- Ensure that the gas cap adapters are in good working order
- Perform Pass/Fail calibration on the Waekon tester
- Perform a performance check for the gas cap tester
- Ensure that the proper station information is printing out on the VIR

All PIFs will be responsible for proper routine maintenance of the test system. The specific routine maintenance will be based on the configuration purchased. For OBDII only systems, there is very little routine maintenance other than adding paper and toner

NEW JERSEY OPERATORS INSTRUCTION MANUAL

EQUIPMENT MAINTENANCE

to the printer and a periodic calibration of the gas cap tester. However, stations that purchase the gas analytical system will need to follow routine maintenance schedule.

The schedule will include, but is not limited to:

Routine Maintenance	Requirement
Bowl Filters	Monthly (as needed)
Calibration Bottles	Change when empty
Hoses/Probe Tips (including diesel cables/hoses)	Replace when needed
Toner Cartridge	Replace when needed
Diesel Optics	Clean as required

NEW JERSEY OPERATORS INSTRUCTION MANUAL

MOBILE WORKSTATION HANDHELD USE

CHAPTER 13: MOBILE WORKSTATION

HANDHELD USE IN THE MOBILE WORKSTATION

There are four main areas where the handheld can be used in the NJ Workstation:

1. Scanning barcodes,
2. Gas analyzer emissions tests,
3. MIL tests, and
4. OBD emissions tests.

Handheld Prompt for Use: When the workstation software displays a picture in picture type screen in the upper left hand corner of the workstation screen, the handheld may be used, see Figure 13-1.



FIGURE 13-1: PICTURE AND PICTURE PROMPT USE HANDHELD

NEW JERSEY OPERATORS INSTRUCTION MANUAL

MOBILE WORKSTATION HANDHELD USE

Start Remote Use:

Click on the “**Start Remote**” icon on the main menu of the handheld to start using the handheld device. The handheld’s screen will then be updated with the picture in picture screen on the workstation itself and key presses on the handheld such as **escape**, **enter**, **Y** and **N** can be used to interact with the workstation as applicable.

When the process where the handheld may be used is over, the picture in picture screen will close and the handheld should be left with the message “**Tap to exit**”. You can then tap on the screen of the handheld to be returned to the main menu on the handheld.

NEW JERSEY OPERATORS INSTRUCTION MANUAL

MOBILE WORKSTATION HANDHELD USE

BARCODE SCANNING - HANDHELD

Screens like the one below will appear anytime the workstation prompts for scanning a barcode with the handheld. The handheld's green SCAN button can then be pressed to scan a barcode from the handheld into the workstation.

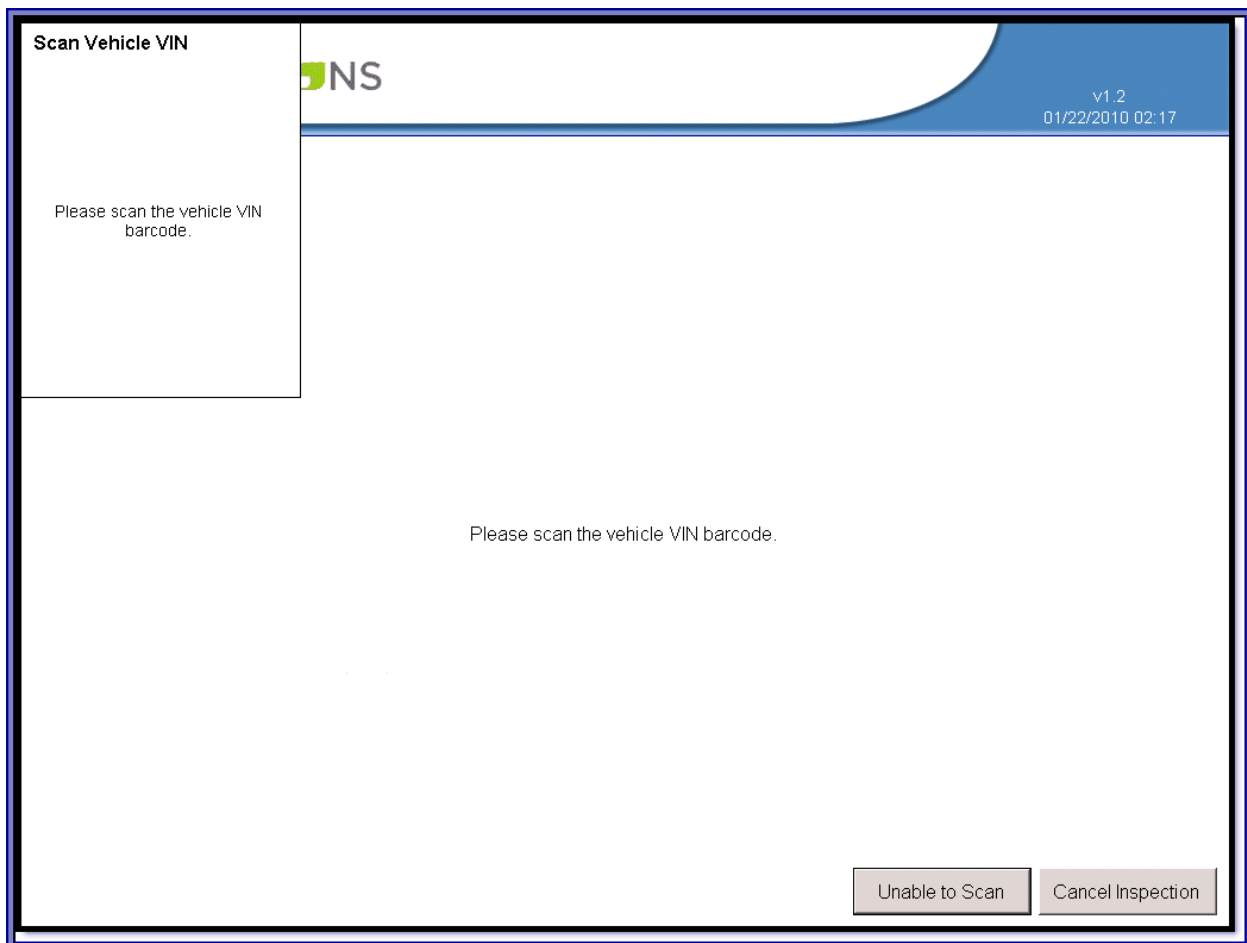

FIGURE 13-2: SCAN VEHICLE VIN BARCODE MESSAGE (PROMPT TO USE HANDHELD)

NEW JERSEY OPERATORS INSTRUCTION MANUAL

MOBILE WORKSTATION HANDHELD USE

GAS ANALYZER EMISSIONS TESTS - HANDHELD

During an emissions test that involves the gas analyzer, the RPM tracker will be available on the handheld for viewing inside the vehicle with the handheld. The enter and **arrow** keys at this point can be used on the handheld to click buttons on the screen as needed.

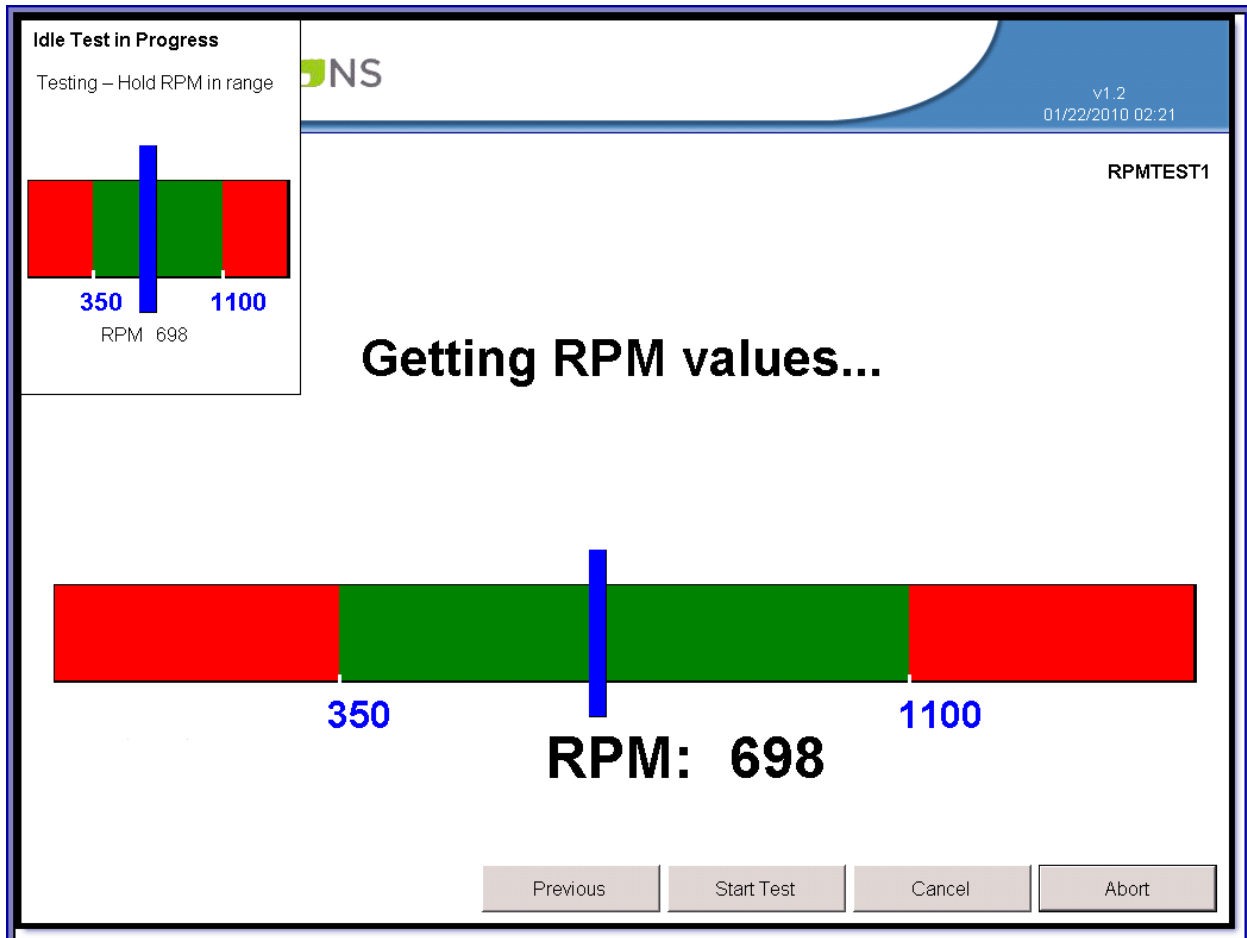

FIGURE 13-3: GETTING RPM VALUES (PROMPT TO USE HANDHELD)

NEW JERSEY OPERATORS INSTRUCTION MANUAL

MOBILE WORKSTATION HANDHELD USE

At the end of a gas analyzer emissions test, the handheld will display the test complete text the same as appears on the workstation screen.

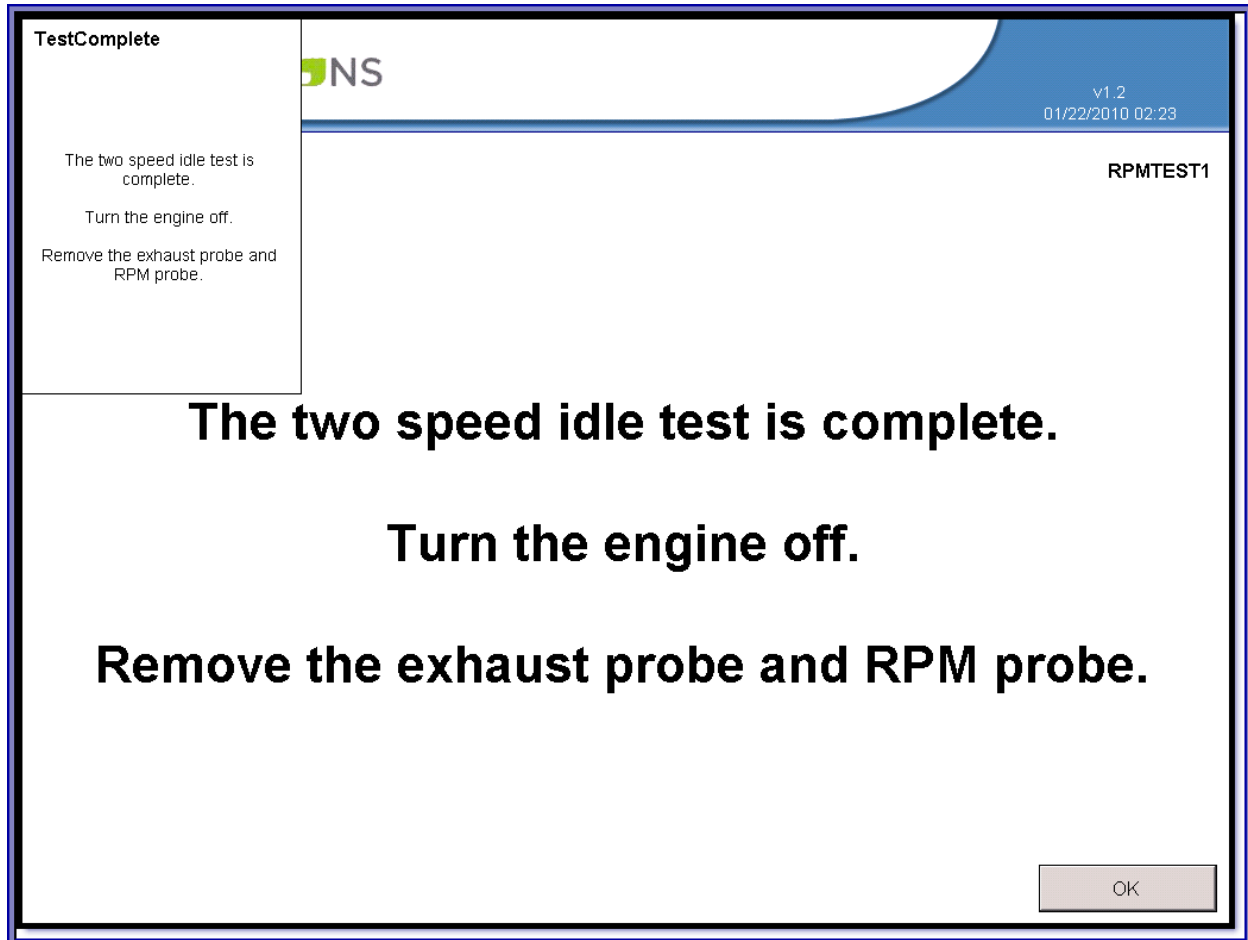

FIGURE 13-4: TEST COMPLETE (HANDHELD MESSAGE)

NEW JERSEY OPERATORS INSTRUCTION MANUAL

MOBILE WORKSTATION HANDHELD USE

MIL TEST - HANDHELD

The MIL test will display the prompts to perform the check on the handheld and will allow the responses to be entered via the keys on the handheld.

The screenshot shows a handheld device interface for a Key On Engine Off (KOEO) test. The screen is divided into a header area and a main content area. The header area includes the text 'v1.2' and '01/22/2010 02:35' in the top right corner, and 'OBDMOB' in the top right corner. The main content area contains the following text: 'Key On Engine Off (KOEO)', 'Turn the key to the on position and keep the engine off.', 'Is the Malfunction Indicator Lamp (MIL) on or flashing?', and 'Press 'Y' for yes or 'N' for no.'. Below this text is a large, bold, black text prompt: 'Turn the ignition key to the on position but do not start the engine. MIL illumination may be continuous or may stay on for a few seconds. Is the Malfunction Indicator Light (MIL) illuminated?'. At the bottom right of the screen are two buttons labeled 'Yes' and 'No'.

FIGURE 13-5: KEY ON ENGINE OFF (KOEO - HANDHELD MESSAGE)

**NEW JERSEY
OPERATORS INSTRUCTION MANUAL**

MOBILE WORKSTATION HANDHELD USE

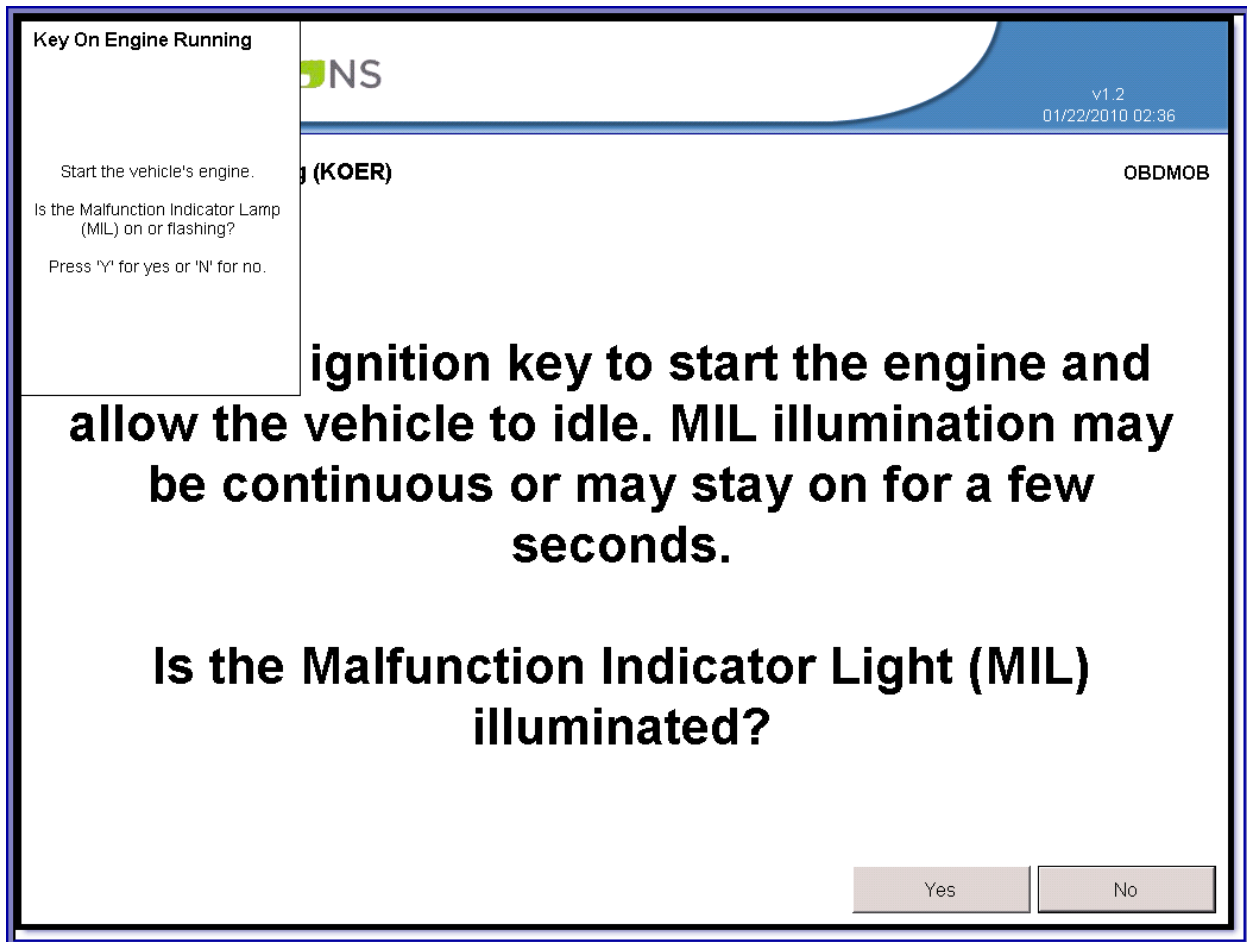

FIGURE 13-6: KEY ON ENGINE RUNNING (KOER - HANDHELD MESSAGE)

NEW JERSEY OPERATORS INSTRUCTION MANUAL

MOBILE WORKSTATION HANDHELD USE

OBD TEST - HANDHELD

The handheld will display notifications at the beginning and end of the OBD test so the inspector may stay in the vehicle the whole time after a successful connection is made until the end of the OBD test.

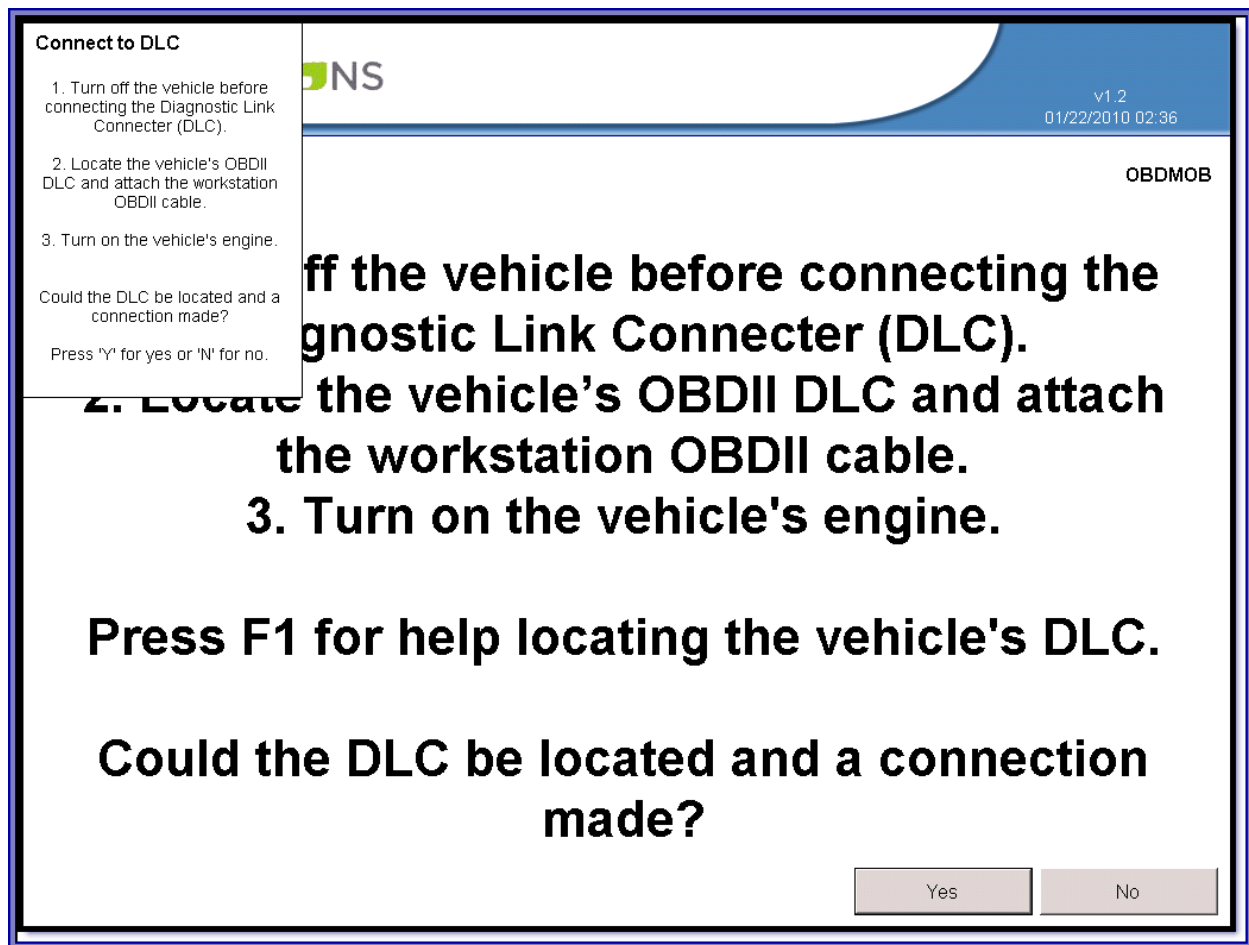

FIGURE 13-7: CONNECT TO DLC (HANDHELD MESSAGE)

**NEW JERSEY
OPERATORS INSTRUCTION MANUAL**

MOBILE WORKSTATION HANDHELD USE

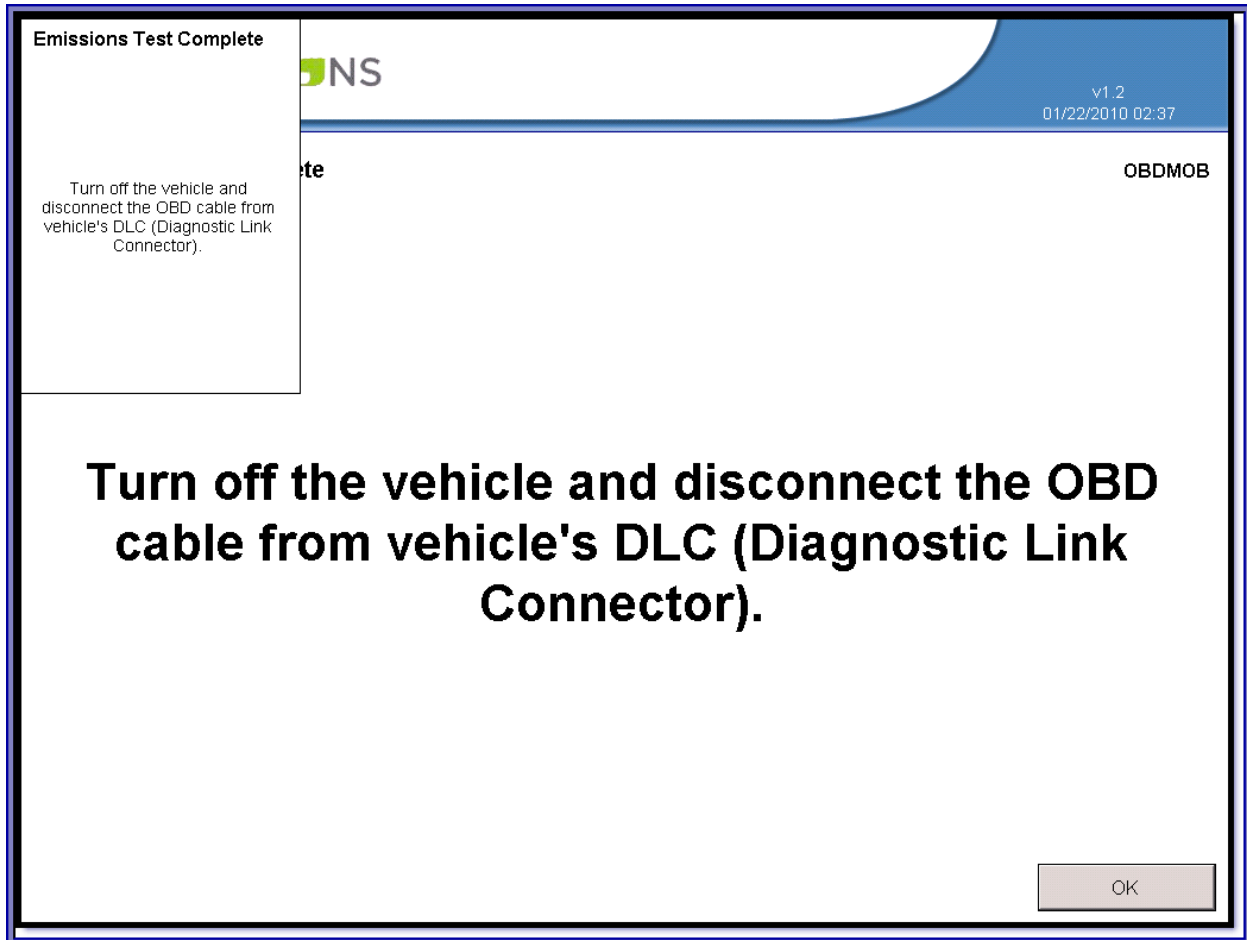

FIGURE 13-8: EMISSIONS TEST COMPLETE (HANDHELD MESSAGE)

**NEW JERSEY
OPERATORS INSTRUCTION MANUAL**

INDEX

Index

NEW JERSEY OPERATORS INSTRUCTION MANUAL

INDEX

- (1) OBDII SCAN., 5-2
- (1) PERFORM INSPECTION, 4-2, 4-1
- (1) VEHICLE INSPECTION MENU, 2-2
- (2) CHANGE WORKSTATION PASSWORD, 9-28
- (2) DIAGNOSTIC MENU, 2-3
- (2) PRINTER AND BARCODE SCANNER CHECK, 6-4
- (3) EQUIPMENT MAINTENANCE., 9-29
- (4) UPDATE SOFTWARE FROM CD., 9-30
- (4) UTILITIES MENU, 2-4
- (5) INTERNET ACCESS SETUP, 9-31
- (5) VIEW MESSAGE, 2-4
- (6) INTERNET CONNECTION CHECK, 9-32
- (6) SERVICE MENU, 2-4
- (7) INITIALIZATION, 9-33
- (7) WORKSTATION MENU, 2-4
- (8) REPORTS MENU, 9-36
- (8) STATE MENU, 2-4
- (9) EDIT FACILITY INFORMATION, 9-37
- (9) REPAIR DATA ENTRY, 2-4
- ABOUT THIS OPERATORS MANUAL, 1-8
- ACCESSING JAMMED AREAS, 11-50
- BAR CODE SCANNER, 1-4
- BARCODE SCANNING - HANDHELD, 13-88
- BIOMETRIC FINGERPRINT READER, 1-6
- CLEARING JAMS, 11-64
- CLEARING JAMS BEHIND THE PHOTO CONDUCTOR KIT AND TONER CARTRIDGE, 11-50
- CLEARING JAMS BEHIND THE REAR DOOR, 11-50
- CLEARING JAMS FROM THE STANDARD EXIT BIN, 11-50
- CLEARING JAMS FROM TRAY 1, 11-50
- CLEARING JAMS FROM TRAY 2, 11-50
- CLEARING JAMS IN THE MANUAL FEEDER, 11-50
- CONTROL BUTTONS DO NOT WORK, 11-44
- DATA FILE REFRESH, 7-12
- EQUIPMENT CHECKS/CALIBRATIONS MENU, 6-2
- GAS ANALYZER EMISSIONS TESTS - HANDHELD, 13-89
- GAS CAP TESTER, 1-5
- GENERAL HELP, 1-8
- HONEYWELL HHP 4600 BARCODE SCANNER TROUBLESHOOTING PROCEDURES:, 11-46
- INTERNET CONNECTION, 1-10
- INTERNET CONNECTION CHECK SCREEN, 7-16

NEW JERSEY OPERATORS INSTRUCTION MANUAL

INDEX

INTRODUCTION, 1-1	SAFETY INFORMATION, 1-8
LASER PRINTER, 1-4	SAFETY INSTRUCTIONS, 1-9
LENOVO PC WITH LCD MONITOR, KEYBOARD, AND OPTICAL MOUSE, 1-3	SAFETY TEST OPTION, 4-16
LOADING NEW SOFTWARE, 3-2	SHUTDOWN, 2-5
MAIN MENU, 2-2	SHUTTING DOWN THE WORKSTATION, 3-2
MIL TEST - HANDHELD, 13-91	SOLVING BASIC PRINTER PROBLEMS, 11-64
MOBILE WORKSTATION, 13-86	SOLVING OPTION PROBLEMS, 11-64
NJ2009 WORKSTATION, 1-2	SOLVING PAPER FEED PROBLEMS, 11-64
NJ2009 WORKSTATION HELP, 1-8	SOLVING PRINT QUALITY PROBLEMS, 11-64
NJ2009 WORKSTATION OPERATION, 3-1	SOLVING PRINTING PROBLEMS, 11-64
NO POWER, 11-44	SYSTEM REQUIREMENTS, 1-10
OBD TEST - HANDHELD, 13-93	THE DIAGNOSTIC MENU (2), 5-1
OBDII INTERFACE MODULE, 1-5	THE UTILITIES MENU, 7-10
OPERATING RANGE, 1-10	TROUBLESHOOTING, 11-44
OPTIONAL EQUIPMENT, 1-2	TURNING THE WORKSTATION ON, 3-1
POWER, 1-10	UNDERSTANDING JAM LIGHTS AND ACCESS LOCATIONS, 11-50
POWER IS ON BUT NO SCREEN IMAGE, 11-44	VEHICLE INSPECTION MENU (1), 4-1
PRINTER JAMS, 11-50	VIEW MESSAGES, 8-20
REPAIR DATA ENTRY, 10-40	WAEKON FPT27 GAS CAP TESTER TROUBLESHOOTING PROCEDURES, 11-48
RISK OF ELECTRIC SHOCK, 1-9	WARNING SYMBOLS, 1-8
RISK OF PERSONAL INJURY, 1-10	

NEW JERSEY OPERATORS INSTRUCTION MANUAL

INDEX

WORKSTATION MANAGEMENT MENU, 9-24

WORKSTATION OPERATION CAUTIONS, 3-1

WORKSTATION STATUS SCREEN., 7-12, 7-13, 7-14,
7-15, 7-16, 7-17

WRONG OR ABNORMAL COLORS, 11-44

