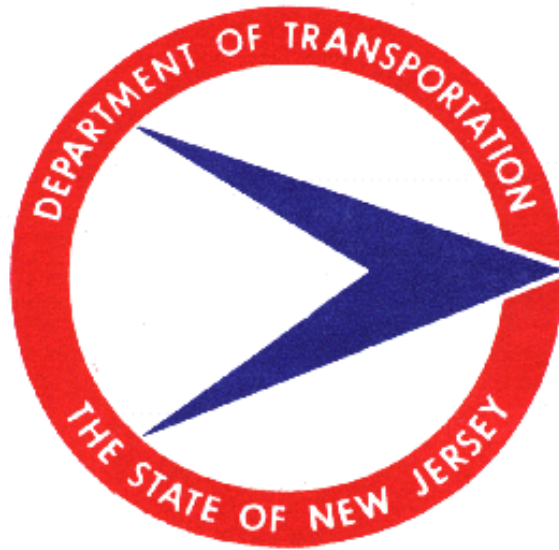


ROADWAY DESIGN MANUAL



2015

Table of Contents

Section 1 - Introduction	1
1.1 Introduction	1
1.2 Policy on Use of AASHTO Standards.....	2
1.3 Reference Publications	2
Section 2 - General Design Criteria	1
2.1 General.....	1
2.2 Highway Classification	1
2.2.1 General	1
2.2.2 Principal Arterial Highways.....	1
2.2.3 Minor Arterial Highways.....	2
2.2.4 Collector Roads	2
2.2.5 Local Roads.....	2
2.3 Design Controls	2
2.3.1 General	2
2.3.2 Primary Controls.....	3
2.3.3 Secondary Controls	4
Section 3 - Definitions and Terminology	1
3.1 General.....	1
3.2 Cross-Section Terminology	1
3.3 Roadway Design Terms.....	6
3.4 Pedestrian Design Terms.....	9
3.5 Bicycle Design Terms.....	10
Section 4 - Basic Geometric Design Elements.....	1
4.1 General.....	1
4.2 Sight Distances	1
4.2.1 General	1
4.2.2 Passing Sight Distance	1
4.2.3 Stopping Sight Distance.....	2
4.2.4 Stopping Sight Distance on Vertical Curves	2
4.2.5 Stopping Sight Distance on Horizontal Curves	2
4.3 Horizontal Alignment	5
4.3.1 General	5
4.3.2 Superelevation	5
4.3.3 Curvature	18
4.4 Vertical Alignment.....	20
4.4.1 General	20
4.4.2 Position with Respect to Cross Section.....	21
4.4.3 Separate Grade Lines	21
4.4.4 Standards for Grade.....	21
4.4.5 Vertical Curves	22
4.4.6 Heavy Grades.....	24
4.4.7 Coordination with Horizontal Alignment	25
4.5 Climbing Lane.....	28
4.6 Through Lane Transition.....	31
Section 5 - Major Cross Section Elements	1
5.1 General.....	1
5.2 Pavement.....	1
5.2.1 Surface Type.....	1
5.2.2 Cross Slope.....	1

5.3	Lane Widths	2
5.4	Shoulders.....	3
5.4.1	General	3
5.4.2	Width of Shoulders.....	4
5.4.3	Cross Slope.....	5
5.4.4	Intermittent Shoulders or Turnouts	6
5.5	Roadside or Border.....	6
5.5.1	General	6
5.5.2	Width	6
5.5.3	Fencing	7
5.6	Curbing.....	7
5.6.1	General	7
5.6.2	Types of Curb.....	8
5.6.3	Placement of Curb	9
5.6.4	Curb Height	9
5.7	Sidewalk	9
5.7.1	General	9
5.7.2	Pedestrian Needs	11
5.7.3	Sidewalk Design	12
5.7.4	Public Sidewalk Curb Ramp	13
5.8	Driveways	21
5.8.1	Pedestrian Accommodations at Driveways.....	21
5.9	Medians	22
5.9.1	General	22
5.9.2	Islands, Medians, and Pedestrian Refuges	22
5.9.3	Median Fencing on Land Service Highways.....	24
5.10	Standard Typical Sections	25
5.11	Bridges and Structures	26
5.11.1	General	26
5.11.2	Lateral Clearances	26
5.11.3	Vertical Clearance.....	26
5.12	Rumble Strips.....	26
5.12.1	General	26
5.12.2	Shoulder Rumble Strips	26
5.12.3	Centerline Rumble Strips	27
Section 6 - At Grade Intersections		1
6.1	General.....	1
6.2	General Design Considerations.....	2
6.2.1	Capacity Analysis.....	2
6.2.2	Spacing	2
6.2.3	Alignment and Profile	2
6.2.4	Cross Section	3
6.3	Sight Distance	3
6.3.1	General	3
6.3.2	Sight Distance for Bicycle Facilities.....	3
6.3.3	Stop Control on Cross Street.....	4
6.3.4	Yield Control	4
6.3.5	Sight Distance at Signalized Intersections.....	5
6.4	Vehicular Turning Movements	8
6.4.1	General	8
6.4.2	Design Vehicles	8
6.4.3	Turning Radii at Unchannelized Intersections.....	8
6.5	Channelization	11
6.5.1	General	11
6.5.2	Islands.....	11

6.5.3	Auxiliary Lanes	16
6.5.4	Median Openings	19
6.5.5	Median Openings for Emergency Vehicles.....	22
6.6	Median Left-Turn Lane	25
6.6.1	General	25
6.6.2	Lane Width	25
6.6.3	Length.....	25
6.7	Continuous Two-Way Left-Turn Median Lane	27
6.7.1	General	27
6.7.2	Lane Width	28
6.7.3	Cross Slope.....	28
6.8	Jughandles	30
6.8.1	General	30
6.8.2	Ramp Width	30
6.8.3	Access Control.....	30
6.8.4	Standard Jughandle Designs	30
6.8.5	Superelevation and Cross Slope.....	31
6.8.6	Crosswalks, Pavement Markings and Bike Lanes	32
6.9	Other Considerations	36
6.9.1	Parking Restrictions at Intersections.....	36
6.9.2	Lighting at Intersections	36
6.10	Bus Turnouts	36
6.10.1	Introduction	36
6.10.2	Location Criteria	36
6.10.3	Other Considerations.....	37
6.10.4	Bus Turnout Design Criteria	38
Section 7 - Interchanges.....		1
7.1	General.....	1
7.2	Warrants for Interchanges.....	1
7.2.1	Freeways and Interstate Highways.....	1
7.2.2	Other Highways.....	1
7.3	Interchange Types	2
7.3.1	General	2
7.4	Interchange Design Elements	3
7.4.1	General	3
7.4.2	Spacing	3
7.4.3	Sight Distance.....	3
7.4.4	Alignment, Profile and Cross Section	3
7.5	Ramps.....	3
7.5.1	General	3
7.5.2	Ramp Capacity	3
7.5.3	Design Speed	3
7.5.4	Grades (Profile)	4
7.5.5	Sight Distance.....	4
7.5.6	Widths.....	4
7.5.7	Location of Ramp Intersection on Cross Road	4
7.6	Superelevation and Cross Slope for Interchange Ramps	8
7.7	Freeway Entrances and Exits	8
7.7.1	Basic Policy	8
7.7.2	Ramp Terminals	8
7.7.3	Distance between Successive Exits.....	9
7.7.4	Auxiliary Lane Lengths	10
7.7.5	Curbs	10
7.8	Additional Lanes.....	18
7.9	Lane Reduction	18

7.10	Route Continuity	18
7.11	Weaving Sections.....	18
7.12	Access Control	18
7.13	Bicycle and Pedestrian Accommodations	19
7.14	Collector – Distributor Roads	19
Section 8 -Guide Rail and Median Barriers		1
8.1	Introduction	1
8.2	Guide Rail Warrants.....	1
8.2.1	General	1
8.2.2	How Warrants are Determined.....	1
8.2.3	Clear Zone	1
8.2.4	Warrants	2
8.3	Dimensional Characteristics	9
8.3.1	Guide Rail Offset.....	9
8.3.2	End Treatments	12
8.3.3	Roadside Recovery Area	15
8.3.4	Approach Length of Need (L.O.N.)	16
8.3.5	Nonvegetative Surface Under Guide Rail	17
8.3.6	Sidewalks	19
8.3.7	Underground Structures	20
8.3.8	Guide Rail Details	21
8.3.9	General Comments	22
8.4	Median Barrier	23
8.4.1	Warrants for Median Barriers.....	23
8.4.2	Median Barrier Type.....	24
8.4.3	Median Barrier Location	25
8.4.4	Emergency and Maintenance U-Turns.....	26
8.4.5	Median Barrier End Treatments	26
8.5	Diversions Roads (Road Closure with Diversion).....	27
Section 9 - Crash Cushions.....		1
9.1	Introduction	1
9.2	Selection Guidelines	1
9.2.1	General	1
9.2.2	Dimensions of the Obstruction.....	5
9.2.3	Space Requirement.....	6
9.2.4	Geometrics of the Site.....	17
9.2.5	Physical Conditions of the Site.....	17
9.2.6	Redirection Characteristics.....	17
9.2.7	Design Speed	17
9.2.8	Foundations	17
9.2.9	Backup Structure Requirements.....	19
9.2.10	Anchorage Requirements	20
9.2.11	Flying Debris Characteristics	20
9.2.12	Initial Cost.....	20
9.2.13	Maintenance.....	21
9.3	Design Procedure	21
9.3.1	Inertial Barriers	21
9.3.2	Compressive Barriers	27
9.4	Product Information.....	33
Section 10 - Drainage.....		1
10.1	General Information	1
10.1.1	Introduction	1
10.1.2	Definitions and Abbreviations	2

10.1.3	Design Procedure Overview	3
10.2	Drainage Policy	5
10.2.1	Introduction	5
10.2.2	Stormwater Management and Non-Point Source Pollution Control	5
10.2.3	Allowable Water Surface Elevation	9
10.2.4	Recurrence Interval	10
10.2.5	Increasing Fill Height Over Existing Structures	10
10.2.6	Regulatory Compliance	10
10.2.7	Flood Hazard Area (Stream Encroachment)	12
10.2.8	Soil Erosion and Sediment Control	16
10.3	Hydrology	16
10.3.1	Introduction	16
10.3.2	Selection of Hydrologic Methods	16
10.3.3	Rational Formula	18
10.3.4	US Natural Resources Conservation Service (NRCS) Methodology	26
10.3.5	Time of Concentration (T_c)	29
10.3.6	Flood Routing	30
10.4	Channel Design	33
10.4.1	Introduction	33
10.4.2	Channel Type	33
10.4.3	Site Application	33
10.4.4	Channel Design Procedure	34
10.5	Drainage of Highway and Pavements	36
10.5.1	Introduction	36
10.5.2	Runoff Collection and Conveyance System Type	36
10.5.3	Types of Inlets Used by NJDOT	37
10.5.4	Flow in Gutters (Spread).....	38
10.5.5	Limits of Spread	39
10.5.6	Inlets	40
10.5.7	Capacity of Gutter Inlets on Grade	41
10.5.8	Capacity of Grate Inlets at Low Points	42
10.5.9	Location of Inlets	43
10.5.10	Spacing of Inlets.....	43
10.5.11	Depressed Gutter Inlet	44
10.5.12	Snow Melt Control.....	44
10.5.13	Alternative Runoff Collection Systems	45
10.6	Storm Drains	46
10.6.1	Introduction	46
10.6.2	Criteria for Storm Drains.....	46
10.6.3	Storm Sewer Design	49
10.6.4	Preliminary Pipe Size.....	50
10.6.5	Hydraulic Grade Line computations	54
10.7	Median Drainage	63
10.7.1	Introduction	63
10.7.2	Median Inlet Type	63
10.7.3	Median Design Criteria - Continuous Grade	63
10.7.4	Procedure for Spacing Median Drains	63
10.8	Culvert Design	64
10.8.1	Introduction	64
10.8.2	Culvert Types	64
10.8.3	Culvert Location	64
10.8.4	Culvert Selection	64
10.8.5	Culvert Hydraulics.....	64
10.8.6	Culvert End Structures	65
10.8.7	Flood Routing at Culverts.....	65

10.8.8	Aquatic Species (Including Fish) Passage	66
10.9	Conduit Outlet Protection	69
10.9.1	Riprap Size and Apron Dimensions	69
10.9.2	Energy Dissipators	69
10.10	Reset Castings - Manholes and Inlets.....	70
10.10.1	Reset Castings and Construction Practices	70
10.10.2	Extension Rings and Frames.....	70
10.10.3	Extension Rings - Manholes.....	71
10.10.4	Extension Frames - Inlets	71
10.10.5	Ramping.....	72
10.11	Stormwater Management	72
10.11.1	Introduction	72
10.11.2	Methodology	73
10.11.3	Stormwater Management Facility Locations.....	75
10.11.4	Stormwater Management Facility Design Features	75
10.11.5	Stormwater Management Facility Maintenance	79
10.12	Water Quality	79
10.12.1	Introduction	79
10.12.2	Methodology	79
10.12.3	Water Quality Treatment Facilities and Design	80
10.12.4	Scour Considerations.....	82
10.13	Sample Hydrologic and Hydraulic Calculations.....	83
10.13.1	Sample Hydraulic Calculations	87
10.13.2	Sample Hydrologic Calculations	97
Section 11 - Highway Lighting Systems		1
11.1	General.....	1
11.2	Reference Publications	1
11.3	General Design Criteria	2
11.3.1	Warrants for Highway Lighting	2
11.3.2	Selection of Types of Highway Lighting	3
11.3.3	Level of Illuminance	5
11.3.4	Uniformity of Illuminance.....	5
11.3.5	Basis for Lighting Calculation.....	5
11.3.6	Lighting Calculations	7
11.3.7	Underdeck Lighting	8
11.3.8	Conduit	9
11.3.9	Cables and Wire	9
11.3.10	Junction Boxes and Foundations	9
11.3.11	Incoming Service.....	10
11.3.12	Load Center Designations	10
11.3.13	Circuitry and Other Considerations.....	10
11.4	Sign Lighting	11
11.5	Existing Highway Lighting System	12
11.6	Temporary Lighting	12
11.6.1	Designing the Temporary Lighting.....	12
11.7	Highway Lighting Plans	12
11.8	Lighting at Intersections	13
11.9	Non-Functional Historic Replica Lighting	13
11.10	Functional Historic Lighting.....	13
11.11	Mid-Block Pedestrian Crossing	14
11.12	Roundabout Lighting.....	14
11.13	Pedestrian Crosswalks	14
11.14	Light Trespass from Off-Site Development.....	14
11.15	Voltage Drop Calculation Method.....	26

Section 12 - Traffic Signal Design	1
12.1 General.....	1
12.2 Reference Publications	1
12.3 General Design Criteria	2
12.3.1 Warrants for Traffic Signals.....	2
12.3.2 Traffic Signal Design –“TS” Plan - General.....	2
12.3.3 Traffic Signal Timing and Operation - General	5
12.3.4 Pedestrian Timing Considerations - General	7
12.3.5 Pre-Emption.....	7
12.3.6 Temporary Traffic Signals	8
12.3.7 Traffic Signal Controller	9
12.3.8 Traffic Signal Standards.....	10
12.3.9 Traffic Signal Indications.....	11
12.3.10 Intersection Lighting	11
12.3.11 Conduits.....	11
12.3.12 Cables and Wires	11
12.3.13 Vehicular Detection.....	12
12.3.14 Junction Boxes	14
12.3.15 Incoming Service.....	14
Section 13 - Ground Mounted Sign Supports	1
13.1 Introduction	1
13.2 Small Highway Signs	2
13.3 Large Highway Signs	4
13.3.1 Breakaway Sign Supports	7
13.3.2 Non - Vegetative Surface under Overhead Signs and Large Ground Mounted Signs.....	17
13.4 Raised Pavement Markers	Error! Bookmark not defined.
13.5 Traffic Stripes and Traffic Markings.....	Error! Bookmark not defined.
Section 14 - Traffic Control Plans and Details	1
14.1 Introduction	1
14.2 General.....	1
14.3 Traffic Control and Staging Plans.....	2
14.4 Traffic Impact Report.....	3
14.5 Development of Traffic Control Plan Design Parameters	3
14.6 Latex Traffic Stripes and Traffic Markings	5
14.7 Lane and Roadway Closures	5
14.7.1 Lane Closures.....	5
14.7.2 Total Roadway Closures.....	6
14.7.3 Center/Interior Lane Closures.....	7
14.7.4 Alternate Traffic Routes	8
14.7.5 Temporary Emergency Pull-Off	9
14.8 Construction Barrier Curb.....	9
14.8.1 Introduction	9
14.8.2 Warrants	10
14.8.3 Applications	11
14.9 Construction Barrier Curb, Moveable System	15
14.9.1 Warrants	15
14.9.2 Applications	15
14.9.3 Safety and Cost Considerations	16
14.10 Nighttime Construction	17
14.11 Construction Details	18
14.11.1 Crash Cushions.....	18
14.11.2 Signs	18
14.11.3 Guide Rail.....	19

14.12	Utilities	19
14.13	Quantities	19
14.14	Installation and Removal Sequence for Work Zone Traffic Control	19
14.15	Traffic Control Plan Submission Requirements.....	20
14.15.1	Initial Submission: Investigate project site specific conditions and Prepare Preliminary Staging Plans:.....	20
14.15.2	Final Submission: Prepare Final Traffic Control Plans and Staging Plans:.....	21
14.16	Quality Control Checklist for Designers	24
Section 15 - Traffic Calming		1
15.1	Introduction	1
15.1.1	General	1
15.1.2	Objective	1
15.1.3	Definition.....	1
15.1.4	References.....	1
15.1.5	Principles	1
15.2	General Traffic Calming Design Controls.....	2
15.2.1	Design Speed	2
15.2.2	Clear Zone and Streetscape	2
15.2.3	Signs and Markings.....	3
15.3	Traffic Calming Design Standards.....	3
15.3.1	Volume Control Devices.....	3
15.3.2	Speed Control Devices – Vertical Speed Table	6
15.3.3	Speed Control Devices - Horizontal	13
15.3.4	Other Devices	19
15.3.5	Combination Treatments.....	20

Section 1 - Introduction

1.1 Introduction

This manual presents the current Department guidelines pertaining to roadway design on the State Highway system (www.state.nj.us/transportation/refdata/sldiag/). It provides a means of developing uniformity and safety in the design of a highway system consistent with the needs of the motoring and non-motoring users.

It is recognized that situations occur where good engineering judgment will dictate deviation from the current Department design guidelines. Any such deviations from design guidelines relative to the following controlling design elements (CDE's), as contained in Sections 4 through 7, will require an approved design exception (Except where Exempted by the *NJDOT Design Exception Manual*):

Controlling Design Elements (Roadway)

- Stopping Sight Distance (vertical curves, horizontal curves, and non-signalized intersections)
- Superelevation (for mainline and ramps)
- Minimum Radius of Curve (for mainline and ramps)
- Minimum and Maximum Grades
- Cross Slope
- Lane Width (through and auxiliary)
- Shoulder Width
- Through Lane Drop Transition Length
- Acceleration and Deceleration Lane Length (for ramps)
- Horizontal Clearance (N/A in New Jersey – minimum allowable offset 0'-0")
- Design Speed (a design exception for a reduction in the design speed will not be approved)

Controlling Design Elements (Structural)

- Bridge Width
- Vertical Clearance
- Design Loading

The above Controlling Design Element (CDE) list is in accordance with the *Design Exception Manual*.

The guidelines contained in this manual, other than the CDE's shown above, are primarily informational or guidance in character and serve to assist the engineer in attaining good design. Deviations from this information or guidance do not require a design exception.

It is not the intent of this manual to reproduce all the information that is adequately covered by textbooks and other publications which are readily available to designers and technicians.

This manual, when used in conjunction with engineering knowledge of highway design and good judgment, should enable the designer to perform their job more efficiently.

The geometric design of streets and highways not on the State Highway system should conform to the standards as indicated in the current *AASHTO – A Policy on*

Geometric Design of Highways and Streets. The design of traffic barriers and drainage systems shall conform to the *NJDOT Roadway Design Manual*.

1.2 Policy on Use of AASHTO Standards

The American Association of State Highway and Transportation Officials (AASHTO) has published policies on highway design practice. These are approved references to be used in conjunction with this manual. AASHTO policies represent nationwide standards that do not always satisfy New Jersey conditions. When standards differ, the instructions in this manual shall govern except on Interstate highways. The geometric design of the Interstate System, as a minimum, shall comply with the standards presented in the AASHTO publications; but the design of traffic barriers shall conform to the *NJDOT Roadway Design Manual*.

1.3 Reference Publications

- **Note: If there is a date given for the publication and a revised edition exists, use the current FHWA approved edition.**
- A. American Association of State Highway and Transportation Officials (AASHTO), American Association of State Highway Officials (AASHO)
 - AASHTO – *A Policy on Geometric Design of Highways and Streets*, 2011
 - AASHTO – *A Policy on Design Standards - Interstate System*, 2005
 - AASHTO – *Roadside Design Guide*, 2006
 - AASHTO – *A Guide for the Development of Rest Areas on Major Arterials and Freeways*, 2001
 - AASHTO – *Guide for the Development of Bicycle Facilities*, 2012
 - AASHTO – *An Informational Guide for Roadway Lighting*, (1984)
 - AASHTO – *Guide for the Planning, Design and Operation of Pedestrian Facilities*, 2004
 - AASHO – *Highway Definitions*, 1968
 - AASHO – *A Policy on U-Turn Median Openings on Freeways*, 1960
- B. Transportation Research Board (TRB)
 - TRB – *Highway Capacity Manual*, (2010)
- C. Federal Highway Administration (FHWA)
 - FHWA – National Transportation Communications for ITS Protocol <http://www.ntcip.org/info/>
 - FHWA – Federal-Aid Policy Guide (FAPG), (1991 with Updates)
 - FHWA – Roundabouts: An Informational Guide, (2000), Publication No. FHWA-RD-00-067
 - FHWA – *Roadway Lighting Handbook*, (1978 and Addendums)
 - FHWA – Pedestrian Facilities Users Guide: Providing Safety and Mobility Publication No. FHWA-RD-01-102 (1999)
 - System Engineering Guidebook for ITS, (2007), <http://www.fhwa.dot.gov/cadiv/segb/>
 - FHWA – Manual on Uniform Traffic Control Devices, (2009)
- D. Institute of Transportation Engineers (ITE)
 - ITE – *Alternative Treatments for At-Grade Pedestrian Crossings*, (2001)

- E. Illuminating Engineering Society North America (IESNA)
 - IESNA – *Lighting Handbook*, 9th (2000)
- F. National Fire Protection Association
 - *National Electrical Code (NEC)*, (2008)
 - *National Electrical Code (NEC) Handbook*, (2008)
- G. New Jersey Department of Transportation (NJDOT)
 - NJDOT – *Bicycle Compatible Roadways and Bikeways: Planning and Design Guidelines*, (1996)
 - NJDOT – *Pedestrian Compatible Planning and Design Guidelines*, (1996)
 - *NJ Statewide ITS Architecture*, (2005)
 - *2017 State of New Jersey: Complete Streets Design Guide*
- H. National Committee on Uniform Traffic Laws and Ordinances (NCUTLO)
 - NCUTLO – *Uniform Vehicle Code*, (2000)
- I. United States Access Board
 - ADA Access Board – *Recommendations for Accessibility Guidelines: Recreational Facilities and Outdoor Developed Areas*, (Published in the Federal Register July 23, 2004 and as amended through May 7, 2014)
- J. Department of Justice
 - 2010 Standards for Titles II and III Facilities: 2004 ADAAG.
- K. Public Rights-of-way Access Advisory Committee
 - Special Report: Accessible Public Rights-of-Way Planning and Design for Alterations (2007)
- L. Miscellaneous
 - Chicagoland Bicycle Federation BLOS/BCI Form – <http://rideillinois.org/advocacy/bikeped-level-of-service-measures-and-calculators/>
- Calculator for Bicycle Level of Service and Bicycle Compatibility Index

Section 2 - General Design Criteria

2.1 General

Geometric design is the design of the visible dimensions of a highway with the objective of forming or shaping the facility to the characteristics and behavior of drivers, vehicles, and traffic. Therefore, geometric design deals with features of location, alignment, profile, cross section, intersection, and highway types.

2.2 Highway Classification

2.2.1 General

Highway classification refers to a process by which roadways are classified into a set of sub-systems, described below, based on the way each roadway is used. Central to this process is an understanding that travel rarely involves movement along a single roadway. Rather each trip or sub-trip initiates at a land use, proceeds through a sequence of streets, roads and highways, and terminates at a second land use.

The highway classification process is required by federal law. Each state must assign roadways into different classes in accordance with standards and procedures established by the Federal Highway Administration. Separate standards and procedures have been established for rural and urban areas. For a further description of the classification process, see USDOT, FHWA, *Highway Functional Classification: Concepts, Criteria and Procedures*.

2.2.2 Principal Arterial Highways

Principal arterial highways form an inter-connected network of continuous routes serving corridor movements having the highest traffic volumes and the longest trip lengths. In rural areas, travel patterns should be indicative of substantial statewide or interstate travel. In urban areas, principal arterials should carry a high proportion of total urban area travel on a minimum of mileage.

The principal arterial highway system is stratified into the following two sub-systems:

- **Interstate system** - all presently designated routes of the Interstate System.
- **Other principal arterials** - all non-Interstate principal arterials.

"Other principal arterial" highways may be freeways, expressways or land service highways. However, because of the function of principal arterial highways, the concept of service to abutting land should be subordinate to the provision of travel service to major traffic movements. For facilities within the subclass of other principal arterials in urban areas, mobility is often balanced against the need to provide direct access as well as the need to accommodate pedestrians, bicyclists, and transit users. Where permitted, direct access to abutting property should be carefully regulated by license. No absolute right exists for access to a principal highway, and the rights of the traveling public to a safe and efficient roadway must be guaranteed. However, abutting property owners do have a right of reasonable access to the system of highways, unless such right has been acquired by the State.

Except for toll roads, most "other principal arterials" are included in the Federal consolidated primary (FAP) highway system.

2.2.3 Minor Arterial Highways

Minor arterial highways interconnect with and augment the principal highway system. In urban areas, minor arterial highways are usually included in the Federal-aid urban system (FAUS), and serve trips of moderate length at a somewhat lower level of travel mobility. Access to abutting property should be minimized to facilitate traffic flow and safety. In rural areas, minor arterial highways will usually be included in the Federal consolidated primary (FAP) system, and serve trip lengths and travel densities greater than those served by collector roads. Rural minor arterials should provide relatively high overall travel speeds, with minimum interference to through movements consistent with the context of the project area and considering the range or variety of users. Because of the high speeds, access to abutting property should be either controlled or carefully regulated.

2.2.4 Collector Roads

Collector roads primarily serve trips of intracounty rather than statewide importance. Travel speeds and volumes are less than on arterial roadways, but are still high relative to local roads. These roads provide for both land access and traffic circulation. In urban areas, these roads connect neighborhoods or other districts with the arterial system, and will usually be part of the Federal-aid urban system (FAUS). In rural areas, these roads may be subclassified into two groups:

- **Major collectors** - Serve important intracounty traffic corridors and provide service to major county traffic generators. These roads will usually be included in the Federal-aid secondary (FAS) system.
- **Minor collectors** - Serve smaller places and towns and connect locally important traffic generators. These roads usually will not be on a Federal-aid system.

2.2.5 Local Roads

The local street and road system constitutes all roads not included in the higher classifications. These streets and roads provide direct access to abutting land and permit access to the roads of higher classification. They offer the lowest level of mobility. Service to through traffic movement usually is deliberately discouraged, especially in urban areas. The local road system contains the large majority of all roadway mileage in a state, but only a small percentage of total traffic. For example, in New Jersey local roads include 72 percent of total road mileage, but only 16 percent of total vehicular miles traveled.

2.3 Design Controls

2.3.1 General

The location and geometric design of highways are affected by numerous factors and controlling features. These may be considered in two broad categories as follows:

A. Primary Controls

- Highway Classification
- Topography and Physical Features
- Traffic

B. Secondary Controls

- Design Speed
- Design Vehicle
- Capacity

2.3.2 Primary Controls

A. Highway Classification

Separate design standards are appropriate for different classes of roads, since the classes serve different types of trips and operate under different conditions of both speed and traffic volume. The design of streets and highways on the State highway system should conform to the guidelines as indicated in this manual. In special cases of restrictive or unusual conditions, it may not be practical to meet these guide values. For detailed descriptions of the various guide values, please refer to the appropriate Sections of this Manual.

B. Topography and Physical Features

The location and the geometric features of a highway are influenced to a large degree by the topography, physical features, and land use of the area traversed. The character of the terrain has a pronounced effect upon the longitudinal features of the highway, and frequently upon the cross sectional features as well. Geological conditions may also affect the location and the geometrics of the highway. Climatic, soil and drainage conditions may affect the profile of a road relative to existing ground.

Man-made features and land use may also have considerable effect upon the location and the design of the highway. Industrial, commercial, and residential areas will each dictate different geometric requirements.

C. Traffic

The traffic characteristics, volume, composition and speed, indicate the service for which the highway improvement is being made and directly affects the geometric features of design.

The traffic volume affects the capacity, and thus the number of lanes required. For planning and design purposes, the demand of traffic is generally expressed in terms of the design-hourly volume (DHV), predicated on the design year. The design year for new construction and reconstruction is to be 20 years beyond the anticipated date of Plans, Specifications and Estimate (PS&E), and 10 years beyond the anticipated date of PS&E for resurfacing, restoration and rehabilitation projects.

The composition of traffic, i.e., proportion of trucks and buses, is another characteristic which affects the location and geometrics of highways. Types, sizes and load-power characteristics are some of the aspects taken into account.

The following definitions apply to traffic data elements pertinent to design.

ADT Average Daily Traffic - The total volume during a given time period greater than one day but less than one year divided by the number of days actually counted.

AADT Average Annual Daily Traffic - The total yearly volume in both directions of travel divided by 365 days.

DHV Design-Hourly Volume - Normally estimated as the 30th highest hour two-way traffic volume for the design year selected.

K Ratio of DHV to ADT, expressed as a percent.

D The directional distribution of traffic during the design hour. It is the one-way volume in the predominant direction of travel expressed as a percentage of DHV.

T The proportion of trucks, exclusive of light delivery trucks, expressed as a percentage of DHV.

V Design Speed – Expressed in mph.

2.3.3 Secondary Controls

A. Design Speed

"Design Speed" is a selected speed used to determine the various design features of the roadway.

The assumed design speed should be a logical one with respect to topography, anticipated operating speed, the adjacent land use, the presence of bicycle and pedestrian accommodations, and the functional classification of the highway. Except for local streets where speed controls are frequently included intentionally, every effort should be made to use as high a design speed as practicable to attain a desired degree of safety, mobility and efficiency within the constraints of environmental quality, economics, aesthetics and social or political impacts. Once the design speed is selected, all of the pertinent features of the highway should be related to it to obtain a balanced design. Above minimum design values should be used, where practical. On lower speed facilities, use of above-minimum design criteria may encourage travel at speeds higher than the design speed. Some design features, such as curvature, superelevation, and sight distance are directly related to and vary appreciably with design speed. Other features, such as widths of lanes and shoulders, and clearances to walls and rails, are not directly related to design speed, but they affect vehicle speeds. Therefore, wider lanes, shoulders, and clearances should be considered for higher design speeds. Thus, when a change is made in design speed, many elements of the highway design will change accordingly.

Since design speed is predicated on the favorable conditions of climate and little or no traffic on the highway, it is influenced principally by:

- Character of the terrain;
- Extent of man-made features;
- Economic considerations (as related to construction and right-of-way costs).

These three factors apply only to the selection of a specific design speed within a logical range pertinent to a particular system or classification of which the facility is a part.

The design speed (mph) as it relates to the posted speed (mph) is shown below:

**Table 2-1
Design Speed vs. Posted Speed**

Posted Speed	Design Speed *	
	Existing Highways	New Highways or Alignment
20 mph	25 mph	30 mph
25 mph	30 mph	35 mph
30 mph	35 mph	40 mph
35 mph	40 mph	45 mph
40 mph	45 mph	50 mph
45 mph	50 mph	55 mph
50 mph	55 mph	60 mph
55 mph	60 mph	65 mph

* Generally, for freeways and the Interstate system, the design speed shall be 70 mph for either column shown in Table 2-1. But in certain urban areas, the Interstate highway or freeway was designed at 60 mph. Therefore the design speed shall be 60 mph in either column for these areas. Refer to the Traffic Calming Section of this manual for speeds used in traffic calming areas.

B. Design Vehicle

The physical characteristics of vehicles and the proportions of the various size vehicles using the highways are positive controls in geometric design. A design vehicle is a selected motor vehicle, the weight, dimensions and operating characteristics of which are used to establish highway design controls to accommodate vehicles of a designated type. The symbols and dimensions of design vehicles are shown in Table 2-2.

**Table 2-2
Design Vehicles (Dimensions in feet*)**

Design Vehicle		Wheel Base	Overhang		Overall	
Type	Symbol		Front	Rear	Length	Width
Passenger Car	P	11.0	3.0	5.0	19.0	7.0
Single Unit Truck	SU-30	20.0	4.0	6.0	30.0	8.0
Single Unit Truck (three-axle)	SU-40	25.0	4.0	10.5	39.5	8.0
Single Unit Bus	BUS-40	25.3	6.3	9.0	40.5	8.5
Articulated Bus	A-BUS	22+ 19.4 = 41.4	8.6	10.0	60.0	8.5
Semitrailer Intermediate	WB-40	12.5+25.5 = 38	3.0	4.5	45.5	8.0
Semitrailer Large	WB-50	14.6+35.4 = 50	3.0	2.0	55	8.5
Semitrailer Interstate	WB-62	19.5+41.0 = 60.5	4.0	4.5	69.0	8.5

"Double Bottom" Semitrailer	WB-67D	11+23+10+22.5 = 66.5	2.3	3.0	72.3	8.5
Delivery Truck	DL	16	3	5	24	7.5

Source: *A Policy on Geometric Design of Highways and Streets*, AASHTO

- * Design vehicle dimensions are intended for use in the design of roadways and do not define the legal vehicle dimensions in the State.
- * The delivery truck is based on a typical USPS, UPS or FedEx truck.

C. Capacity

1. General

The term "capacity" is used to express the maximum number of vehicles which have a reasonable expectation of passing over a section of a lane or a roadway during a given time period under prevailing roadway and traffic conditions. However, in a broad sense, capacity encompasses the relationship between highway characteristics and conditions, traffic composition and flow patterns, and the relative degree of congestion at various traffic volumes throughout the range from light volumes to those equaling the capacity of the facility as defined above.

Highway capacity information serves three general purposes:

- a. For transportation planning studies to assess the adequacy or sufficiency of existing highway networks to current traffic demand, and to estimate when, in time, projected traffic demand, may exceed the capacity of the existing highway network or may cause undesirable congestion on the highway system.
- b. For identifying and analyzing bottleneck locations (both existing and potential), and for the evaluation of traffic operational improvement projects on the highway network.
- c. For highway design purposes.

2. Level of Service (LOS)

The level of service concept places various traffic flow conditions into 6 levels of service. These levels of service, designated A through F, from best to worst, cover the entire range of traffic operations that may occur.

The factors that may be considered in evaluating level of service include the following.

- Speed and travel time
- Traffic interruptions or restrictions
- Freedom to maneuver
- Safety
- Driving comfort and convenience
- Economy

However, in a practical approach to identifying the level of service, travel time and the ratio of demand volume to capacity are commonly used.

In general, the various levels of service would have the following characteristics:

Level of Service A is free flow, with low volumes and high speeds. Traffic density is low, with speeds controlled by driver desires, speed limits, and physical roadway conditions. There is little or no restriction in maneuverability due to presence of other vehicles. Drivers can maintain their desired speed with little or no delay.

Level of Service B is in the zone of stable flow, with operating speeds beginning to be restricted somewhat by traffic conditions. Drivers still have reasonable freedom to select their speed and lane of operation. Reductions in speed are not unreasonable, with a low probability of traffic flow being restricted. The lower limit (lowest speed, highest volume) of this level of service has been associated with service volumes used in the design of rural highways.

Level of Service C is still in the zone of stable flow, but speeds and maneuverability are more closely controlled by the higher volumes. Most of the drivers are restricted in their freedom to select their own speed, change lanes, or pass. A relatively satisfactory operating speed is still obtained, with service volumes perhaps suitable for urban design practice.

Level of Service D approaches unstable flow, with tolerable operating speeds being maintained though considerably affected by changes in operating conditions. Fluctuations in volume and temporary restrictions to flow may cause substantial drops in operating speeds. Drivers have little freedom to maneuver, and comfort and convenience are low, but conditions can be tolerated for short periods of time.

Level of Service E cannot be described by speed alone, but represents operations at even lower operating speeds than in Level D, with volumes at or near the capacity of the highway. At capacity, speeds are typically, but not always, in the neighborhood of 25 mph; flow is unstable, and there may be stoppages of momentary duration.

Level of Service F describes forced flow operation at low speeds, where volumes are below capacity. These conditions usually result from queues of vehicles backing up from a restriction downstream. The section under study will be serving as a storage area during parts or all of the peak hour. Speeds are reduced substantially and stoppages may occur for short or long periods of time because of the downstream congestion. In the extreme, both speed and volume can drop to zero.

Reference is made to the Transportation Research Board, "*Highway Capacity Manual*," for a thorough discussion on the level of service concept.

3. Service Volume

For highway design purposes, the service volume is related to the "Level of Service" selected for the proposed facility. (No service volumes are defined for Level of Service F). Service volume is defined as the maximum rate of flow which may be accommodated under prevailing traffic and roadway conditions while still maintaining a quality of service appropriate to the indicated Level of Service.

The service volume varies with a number of factors, including:

- Level of service selected;
- Width of lanes;
- Number of lanes;
- Presence or absence of shoulders;
- Grades;
- Horizontal alignment;
- Operating speed;
- Lateral clearance;
- Side friction generated by parking, driveways, intersections, and interchanges;
- Volumes of trucks, buses, and recreational vehicles;
- Spacing and timing of traffic signals.

The objective in highway design is to create a highway of appropriate type with dimensional values and alignment characteristics such that the resulting service volume will be at least as great as the design volume, but not much greater as to represent extravagance or waste. More detailed data on service volume are available in the Transportation Research Board, *“Highway Capacity Manual,”* and AASHTO, *“A Policy on Geometric Design of Highways and Streets”*.

Section 3 - Definitions and Terminology

3.1 General

This section includes general terminology associated with the road cross-section and terms commonly used in highway design. Reference is made to "*Highway Definitions*," AASHTO, 1968.

3.2 Cross-Section Terminology

The elements of the road cross-section are illustrated in Figure 3-A and Figure 3-B and defined as follows:

1. **Highway** - A general term denoting a public way for purposes of vehicular travel, including the entire area within the right-of-way lines. Recommended usage in urban areas, highway, or street; in rural areas, highway or road.
2. **Highway Section** - The portion of the highway included between top of slopes in cut and the toe of slopes in fill.
3. **Roadway** - The portion of the highway, including shoulders, for vehicular use.
4. **Traveled Way** - The portion of the roadway provided for the movement of vehicles, exclusive of shoulders, auxiliary lanes, and bicycle lanes.
5. **Median** - The portion of a divided highway separating the traveled ways for traffic in opposite directions.
6. **Shoulder** - The portion of the roadway contiguous with the traveled way for accommodation of stopped vehicles for emergency use, and for lateral support of the base and surface courses. The shoulder may be used for bicycle travel where allowed. It may also be used by pedestrians in the absence of a sidewalk.
7. **Surfaced Right Shoulder** - That portion of the outside paved shoulder to provide all weather load support.
8. **Surfaced Left Shoulder** - The portion of the median shoulder paved to provide all weather load support.
9. **Profile Line** - The point for control of the vertical alignment. Also, normally the point of rotation for superelevated sections.
10. **Pavement Cross Slope** - Lateral slope across the pavement. See Section 5.2.2.
11. **Shoulder Cross Slope** - Lateral slope across the shoulder. See Section 5.4.3.
12. **Base Course** - The layer or layers of specified or selected material of designed thickness placed on a subbase or subgrade to support a surface course.
13. **Subbase** - The layer or layers of specified or selected material placed on a subgrade to support a base course.

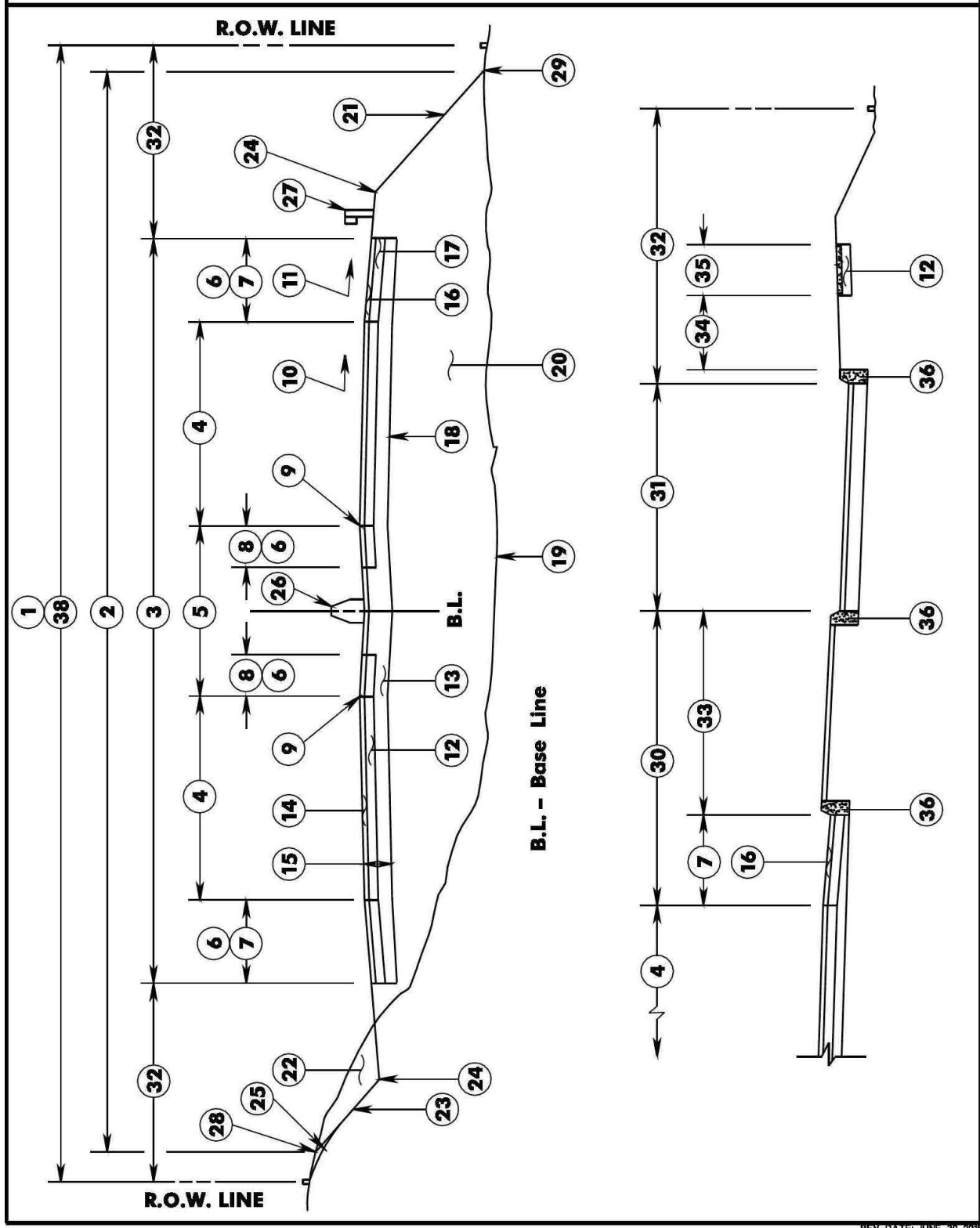
- 14. Surface Course** - One or more layers of a pavement structure designed to accommodate the traffic load, the top layer of which resists skidding, traffic abrasion, and the disintegrating effects of climate.
- 15. Pavement Structure** - The combination of subbase, base course and surface course placed on a subgrade to support the traffic load and distribute it to the roadbed.
- 16. Shoulder Surface Course**
- 17. Shoulder Base Course**
- 18. Subgrade** - The top surface of the roadbed upon which the pavement structure and shoulders are constructed.
- 19. Original (Existing) Ground**
- 20. Embankment (Fill)**
- 21. Fill Slope**
- 22. Cut Section**
- 23. Cut Slope** - Also called cut face.
- 24. Hinge Point (P.V.I.)** - The intersection of shoulder slope planes with fill or cut slope planes.
- 25. Rounding** - At the intersection of existing ground and cut slope.
- 26. Median Barrier** - A longitudinal barrier used to prevent an errant vehicle from crossing the portion of a divided highway separating the traveled ways for traffic in opposite directions.
- 27. Guide Rail** - A barrier whose primary function is to prevent penetration and safely redirect an errant vehicle away from a roadside or median hazard.
- 28. Top of Slope** - The intersection of the cut slope and the original ground.
- 29. Toe of Slope** - The intersection of the fill slope and the original ground.
- 30. Outer Separation** - The portion of an arterial highway, between the traveled ways of a roadway, for through traffic and a frontage road.
- 31. Frontage Road** - Also called marginal road or street. A local road, or street auxiliary, to and located on the side of an arterial highway for service to abutting property and adjacent areas and for control of access.
- 32. Roadside** - The area adjoining the outer edge of the roadway (normally applies to freeways). The term "border" or "sidewalk area" is usually referred to street type facilities.
- 33. Outer Separation Island** - The space in the outer edge of roadway shoulder and frontage roadway shoulder and frontage road or street which may be landscaped or paved depending on width.
- 34. Buffer Strip** - The space in the border area provided to separate the sidewalk from the vehicular travel facilities.
- 35. Sidewalk** - An exterior pathway with a prepared surface (concrete, bituminous, brick, stone, etc.) intended for pedestrian use.

36. Curb or Curb and Gutter

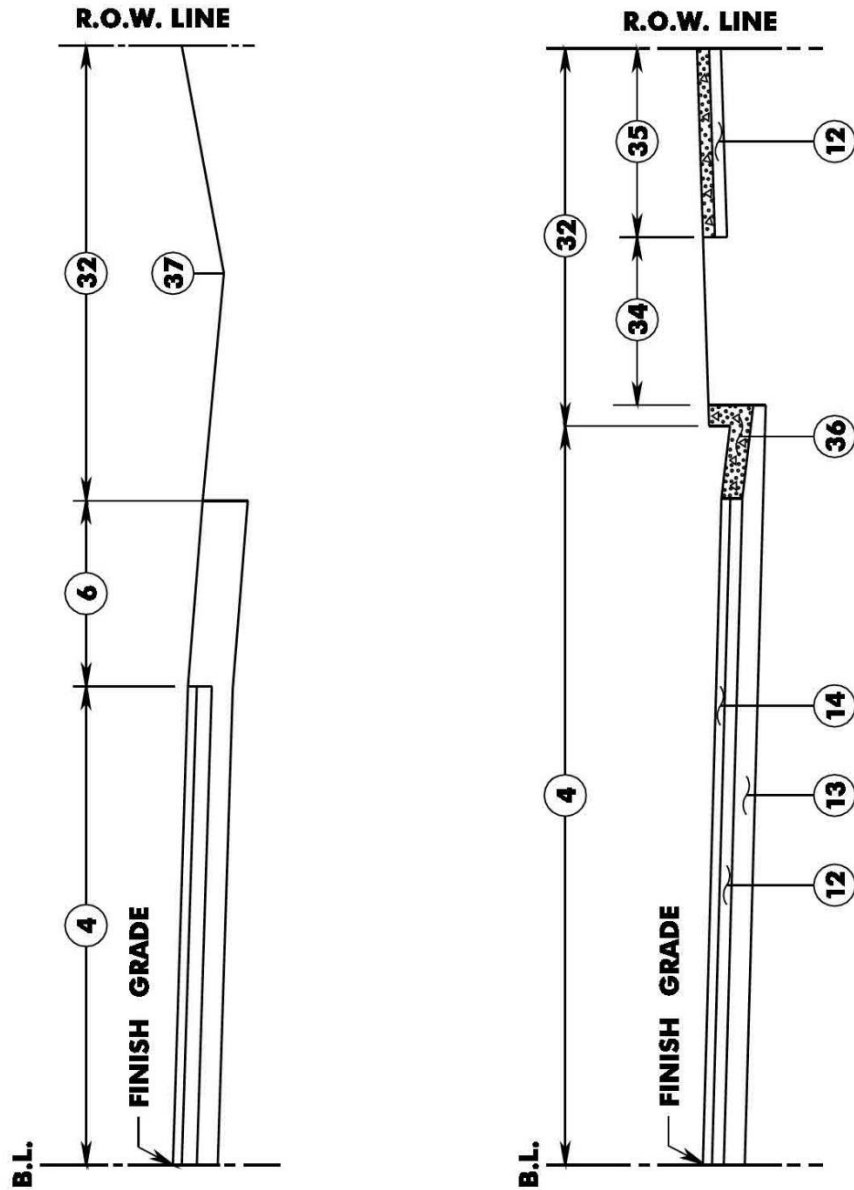
37. Drainage Swale

38. Right-of-Way – A general term denoting land, property, or interest therein, usually in a strip acquired for or devoted to transportation purposes.

**FIGURE 3-A:
ROAD CROSS SECTION TERMINOLOGY**



**FIGURE 3-B:
ROAD CROSS SECTION TERMINOLOGY**



REV. DATE: JUNE 30, 2015

3.3 Roadway Design Terms

Following are terms utilized by Roadway Designers.

3R Project – 3R stands for resurfacing, restoration, and rehabilitation.

Arterial Highway – This is a general term, denoting a highway used primarily for through traffic, usually a continuous route.

Auxiliary Lane - The portion of the roadway adjoining the traveled way intended for speed change, storage, weaving, climbing lane, and for other purposes supplementary to through traffic movement.

- **Acceleration Lane** - An auxiliary lane including tapered areas, primarily for the acceleration of vehicles entering the through traffic lanes.
- **Collector-Distributor Lane** - An auxiliary lane approximately 1/4 to 1/5 mile in length, designated to accommodate right turn access to and from the State highway at more than one location, and normally terminating at an intersection or an interchange ramp. It is not intended for through traffic, and is not physically separated from the through lanes. (Reference: N.J.A.C 16:47-1.1)
- **Deceleration Lane** - An auxiliary lane including tapered areas, primarily for the deceleration of vehicles leaving the through traffic lanes.

Buffer space - The space that separates traffic flow from the work activity and provides recovery space for an errant vehicle. Neither work activity nor storage of equipment, vehicles, or material should occur in this space. Buffer spaces may be positioned longitudinally and laterally, with respect to the direction of traffic flow.

Capacity - The maximum number of vehicles which has a reasonable expectation of passing over a given section of a lane or a roadway in one direction or in both directions for a two-lane or a three-lane highway during a given time period under prevailing roadway and traffic conditions.

Climbing Lane - An auxiliary lane introduced at the beginning of a sustained positive grade in the direction of traffic flow, to be used by slow moving vehicles such as trucks and buses.

Collector-Distributor Road, (C-D) - An auxiliary roadway separated laterally from, but generally parallel to, an expressway which serves to collect and distribute traffic from several access connections between selected points of ingress to and egress from the through traffic lanes. Control of access is exercised outside a C-D Road.

Control of Access - The condition where the rights of owners, occupants or other persons of land abutting a highway to access, light, air or view in connection with the highway are fully or partially controlled by a public agency.

- **Full Control** - The condition under which the authority to control access is exercised to give preference to through traffic to a degree, but in addition to interchange connections with selected public roads there may be some intersections at grade.
- **Partial Control** - The condition under which the authority to control access is exercised to give preference to through traffic to a degree that, in addition to access connections with selected public roads, there may be some crossings at grade and some private driveway connections.

Corridor - A strip of land between two termini within which traffic, topography, environment, and other characteristics, are evaluated for transportation purposes.

Cul-de-Sac - A local street or road open at only one end with special provisions for turning around.

Dead-End Road - A local street or road open only at one end without special provisions for turning around.

Density - The number of vehicles per mile on the traveled way at a given instant.

Design Year - The design year for new construction and reconstruction is to be twenty years beyond the anticipated date of Plans, Specifications and Estimate (PS&E), and ten years beyond the anticipated date of PS&E for resurfacing, restoration and rehabilitation projects. The estimated design year traffic volumes are used as a basis for design.

Direct Connection - A one-way turning roadway that does not deviate greatly from the intended direction of travel.

Directional Design Hourly Volume (DDHV) - An hourly volume determined for use in design, representing traffic expected to use one direction of travel on a highway (Unless otherwise stated it is the directional hourly volume during the 30th highest hour).

Diverging - The dividing of a single stream of traffic into separate streams.

Divided Highway - A highway, street or road with opposing directions of travel separated by a median.

Expressway - A divided multi-lane arterial highway for through traffic, with full or partial control of access, and generally with grade separations at major intersections. On rare occasions, expressways may also include two lane roadways.

Freeway - An expressway with full control of access and grade separations at all intersections.

Frontage Road or Frontage Street - A local street or road auxiliary to and located on the side of an arterial highway, for service to abutting property and adjacent areas, and for control of access.

Gore - The area immediately beyond the divergence of two roadways, bounded by the edges of those roadways.

Grade Separation - A crossing of two highways, or a highway and a railroad at different levels.

Highway Overpass - A grade separation, where the subject highway passes over an intersecting highway or railroad.

Highway Underpass - A grade separation, where the subject highway passes under an intersecting highway or railroad.

Inside Lane - On a multi-lane highway the extreme left hand traffic lane, in the direction of traffic flow, of those lanes available for traffic moving in one direction. This is also referred to as the left lane.

Interchange - A system of interconnecting roadways providing for the movement of traffic between intersection legs.

Land Service Highway - An arterial or collector highway on which access to abutting property is permitted. On arterial highways and major collector roads, such access is usually regulated in order to protect the public safety and maintain the efficiency of the highway.

Left Turn Lane - A speed-change lane, within the median, to accommodate left turning vehicles.

Loads - Traffic data required for the establishment of geometric controls for highway design.

Local Authorities - County, municipal, and other local boards or bodies, having authority to enact laws relating to traffic.

Major Street or Major Road - An arterial highway with intersections at grade and direct access to abutting property, and on which geometric design and traffic control measures are used to expedite the safe movement of through traffic.

Separated Roadways - A highway with opposing directions of travel having independent alignment and gradient.

Shadow Vehicle - A traffic control truck with mounted crash cushions and arrow board showing arrow pattern positioned at an appropriate distance in advance of workers or a work vehicle during a multi-lane road moving operation. The shadow vehicle provides advance information to approaching drivers and shielding of the workers or work vehicle. The work vehicle may be a paint striping truck, cone retrieval truck or other operating vehicle.

Sight Distance - The length of roadway visible to the driver of a vehicle at a given point on the roadway when the view is unobstructed.

Slip Ramp - An angular connection between an expressway and a parallel frontage road.

Stopping Sight Distance - The distance required by a driver of a vehicle, traveling at a given speed, to bring a vehicle to a stop before reaching an object on the roadway after the object has become visible. *The distances used in design are calculated on the basis of the driver's ability to see a 2 foot high object in the road ahead when driver's eye level is 3.5 feet above the roadway surface.*

TCP - Traffic Control Plan - A plan for maintaining traffic in or around a work zone.

Thirtieth Highest Hourly Volume (30HV) - The hourly volume in both directions of travel that is exceeded by 29 hourly volumes during a designated year.

Through Lane - The lane or lanes signed for through traffic continuing through an interchange area.

Through Street, Road or Highway - Any roadway, or portion thereof, on which vehicular traffic is given preferential right-of-way, and at the entrances to which vehicles from intersecting highways are required by law to either stop or yield.

Traffic Control Devices - Signs, Signals, markings, and devices placed or erected for the purpose of regulating, warning, or guiding traffic by authority of a public body or official having jurisdiction over the roadway.

Traffic Barrier - A device used to prevent a vehicle from striking a more severe obstacle or feature located on the roadside or in the median. They are also used to

prevent crossover median accidents. Traffic barriers include roadside barriers, median barriers, bridge railings, and crash cushions.

Traffic Lane - The portion of the roadway for the movement of a single line of vehicles.

Weaving - The crossing of traffic streams moving in the same general direction, accomplished by merging and diverging.

Work Area - A location where construction, maintenance, or a utility/permit operation is being performed.

Work Zone - The work area and the section of highway used for traffic control devices related to the work area.

3.4 Pedestrian Design Terms

Accessible Pedestrian Signal (APS) – A device that communicates information about pedestrian signal timing in non-visual format, by using audible tones (or verbal messages) and vibrating surfaces.

Americans with Disabilities Act – (ADA) 1990 Federal law establishing the civil rights of people with disabilities. Prohibits discrimination against people with disabilities and requires common places used by the public to provide an equal opportunity for access.

Crosswalk – A portion of a roadway designated for pedestrian crossing that can be either marked or unmarked. Definition per NJ Statute Title 39:1-1: ““Crosswalk” means that part of a highway at an intersection included within the connections of the lateral lines of the sidewalks on opposite sides of the highway measured from the curbs or, in the absence of curbs, from the edges of the shoulder, or, if none, from the edges of the roadway; also, any portion of the highway at an intersection or elsewhere distinctly indicated for pedestrian crossing by lines or other marking on the surface.”

Curb Ramp – A combined ramp and landing to accomplish a change in level at a curb, with a running grade steeper than 1:20. This element provides street and sidewalk access to pedestrians.

Detectable Warning – A standardized surface feature built in or applied to walking surfaces or other elements to warn people who are blind or visually impaired of specified hazards.

Leading Pedestrian Interval – The pedestrian “WALK” phase of a traffic signal that begins before the green interval serving parallel traffic, rather than at the same time.

Median Refuge – An area within an island or median that is intended for pedestrians to wait safely for an opportunity to continue crossing the roadway.

Mid-Block Crosswalk – A legally established crosswalk that is not at an intersection.

Pedestrian – A person walking or traveling by means of a wheelchair, electric scooter, crutches or other walking devices or mobility aids. This also includes those pulling or pushing strollers, carriages, carts and wagons, and those walking bicycles.

Pedestrian Access Route – A continuous, unobstructed path connecting all accessible elements of a pedestrian system that meets the requirements of ADAAG (Americans with Disabilities Act Accessibility Guidelines).

Pedestrian Crossing Interval – The combined phases of a traffic signal cycle provided for a pedestrian crossing in a crosswalk, after leaving the top of a curb ramp or flush landing, to travel to the far side of the vehicular way or to a median, usually consisting of the “WALK” interval plus the pedestrian clearance interval.

Pedestrian Signal Indication – The illuminated “WALK,” “DON’T WALK,” message or “Walking Person,” or “Hand” symbol that communicates the pedestrian phase of a traffic signal, and the audible and tactile equivalents.

3.5 Bicycle Design Terms

Bicycle – Every vehicle propelled solely by human power upon which any person may ride, having two tandem wheels, except scooters and similar devices. The term “bicycle” for this publication also includes three and four-wheeled human-powered vehicles, but not tricycles for children.

Bicycle Accommodations – A general term denoting improvements to increase the safety and convenience of bicycling including bicycle compatible roadways and bicycle facilities.

Bicycle Boulevard – A type of shared roadway, designed for bicycle priority.

Bicycle Compatible Roadways – Roadways that provide accommodations for the shared use of bicycles and motor vehicles including adequate operating space and obstacle removal.

Bicycle Facilities – A general term denoting improvements and provisions to accommodate and encourage bicycling, including bikeways and bicycle parking and storage facilities.

Bicycle Lane Or Bike Lane – A portion of a roadway which has been designated by striping, signing and pavement markings for the preferential or exclusive use of bicyclists.

Bicycle Priority – A traffic condition where improvements to accommodate bicycle traffic take precedence over improvements to increase the operating characteristics of motor traffic.

Bicycle Route – A roadway segment designated by the jurisdiction having authority, with appropriate directional and informational markers, with or without a specific bicycle route number.

Bikeway – A generic term for any road, street, path or way which in some manner is specifically designated for bicycle travel, regardless of whether such facilities are designated for the exclusive use of bicycles or are to be shared with other transportation modes.

Shared Roadway – A roadway which accommodates both bicycle and motor vehicle travel. This may be a roadway, street with wide curb lanes, or road with paved shoulders.

Shared Use Path – A bikeway physically separated from motorized vehicular traffic by an open space or barrier. It may be within the highway right-of-way or within an independent right-of-way. Shared use paths may be used by pedestrians, skaters, wheelchair users, joggers, bicyclists and other non-motorized users.

Unpaved Path – Paths not surfaced with asphalt or concrete.

Section 4 - Basic Geometric Design Elements

4.1 General

Geometric highway design pertains to the visible features of the highway. It may be considered as the tailoring of the highway to the terrain, to the controls of the land usage, and to the type of traffic anticipated.

Design parameters covering highway types, design vehicles, and traffic data are included in Section 2, "General Design Criteria."

This section covers design criteria and guidelines on the geometric design elements that must be considered in the location and the design of the various types of highways. Included are criteria and guidelines on sight distances, horizontal and vertical alignment, and other features common to the several types of roadways and highways.

In applying these criteria and guidelines, it is important to follow the basic principle that consistency in design standards is of major importance on any section of road. The highway should offer no surprises to the driver, bicyclist or pedestrian in terms of geometrics. Problem locations are generally at the point where minimum design standards are introduced on a section of highway where otherwise higher standards should have been applied. The ideal highway design is one with uniformly high standards applied consistently along a section of highway, particularly on major highways designed to serve large volumes of traffic at high operating speeds.

4.2 Sight Distances

4.2.1 General

Sight distance is the continuous length of highway ahead visible to the driver. In design, two sight distances are considered: passing sight distance and stopping sight distance. Stopping sight distance is the minimum sight distance to be provided at all points on multi-lane highways and on two-lane roads when passing sight distance is not economically obtainable.

Stopping sight distance also is to be provided for all elements of interchanges and intersections at grade, including driveways.

Table 4-1 shows the standards for passing and stopping sight distance related to design speed.

4.2.2 Passing Sight Distance

Passing sight distance is the minimum sight distance that must be available to enable the driver of one vehicle to pass another vehicle, safely and comfortably, without interfering with the speed of an oncoming vehicle traveling at the design speed, should it come into view after the overtaking maneuver is started. The sight distance available for passing at any place is the longest distance at which a driver whose eyes are 3.5 feet above the pavement surface can see the top of an object 3.5 feet high on the road.

Passing sight distance is considered only on two-lane roads. At critical locations, a stretch of four-lane construction with stopping sight distance is sometimes more economical than two lanes with passing sight distance.

**Table 4-1
Sight Distances for Design**

Design Speed Mph	Sight Distance in feet	
	Stopping Minimum	Passing* Minimum
25	155	450
30	200	500
35	250	550
40	305	600
45	360	700
50	425	800
55	495	900
60	570	1000
65	645	1100
70	730	1200

* Not applicable to multi-lane highways.

4.2.3 Stopping Sight Distance

The minimum stopping sight distance is the distance required by the driver of a vehicle, traveling at a given speed, to bring his vehicle to a stop after an object on the road becomes visible. Stopping sight distance is measured from the driver's eyes, which is 3.5 feet above the pavement surface, to an object 2 feet high on the road.

The stopping sight distances shown in Table 4-1 should be increased when sustained downgrades are steeper than 3 percent. Increases in the stopping sight distances on downgrades are indicated in AASHTO, *"A Policy on Geometric Design of Highways and Streets."*

4.2.4 Stopping Sight Distance on Vertical Curves

See Section 4.4.4 "Standards for Grade" for discussion on vertical curves.

4.2.5 Stopping Sight Distance on Horizontal Curves

Where an object off the pavement such as a longitudinal barrier, bridge pier, bridge rail, building, cut slope, or natural growth restricts sight distance, the minimum radius of curvature is determined by the stopping sight distance.

Stopping sight distance for passenger vehicles on horizontal curves is obtained from Figure 4-A. For sight distance calculations, the driver's eyes are 3.5 feet above the center of the inside lane (inside with respect to curve) and the object is 2 feet high. The line of sight is assumed to intercept the view obstruction at the midpoint of the sight line and 2.75 feet above the center of the inside lane. Of course, the midpoint elevation will be higher or lower than 2.75 feet, if it is located on a sag or crest vertical curve respectively. The horizontal sightline offset (HSO) is measured from the center of the inside lane to the obstruction.

The general problem is to determine the clear distance from the centerline of inside lane to a median barrier, retaining wall, bridge pier, abutment, cut slope, or other obstruction for a given design speed. Using radius of curvature and sight distance for the design speed, Figure 4-A illustrates the HSO, which is the clear distance from

centerline of inside lane to the obstruction. When the design speed and the clear distance to a fixed obstruction are known, this figure also gives the required minimum radius which satisfies these conditions.

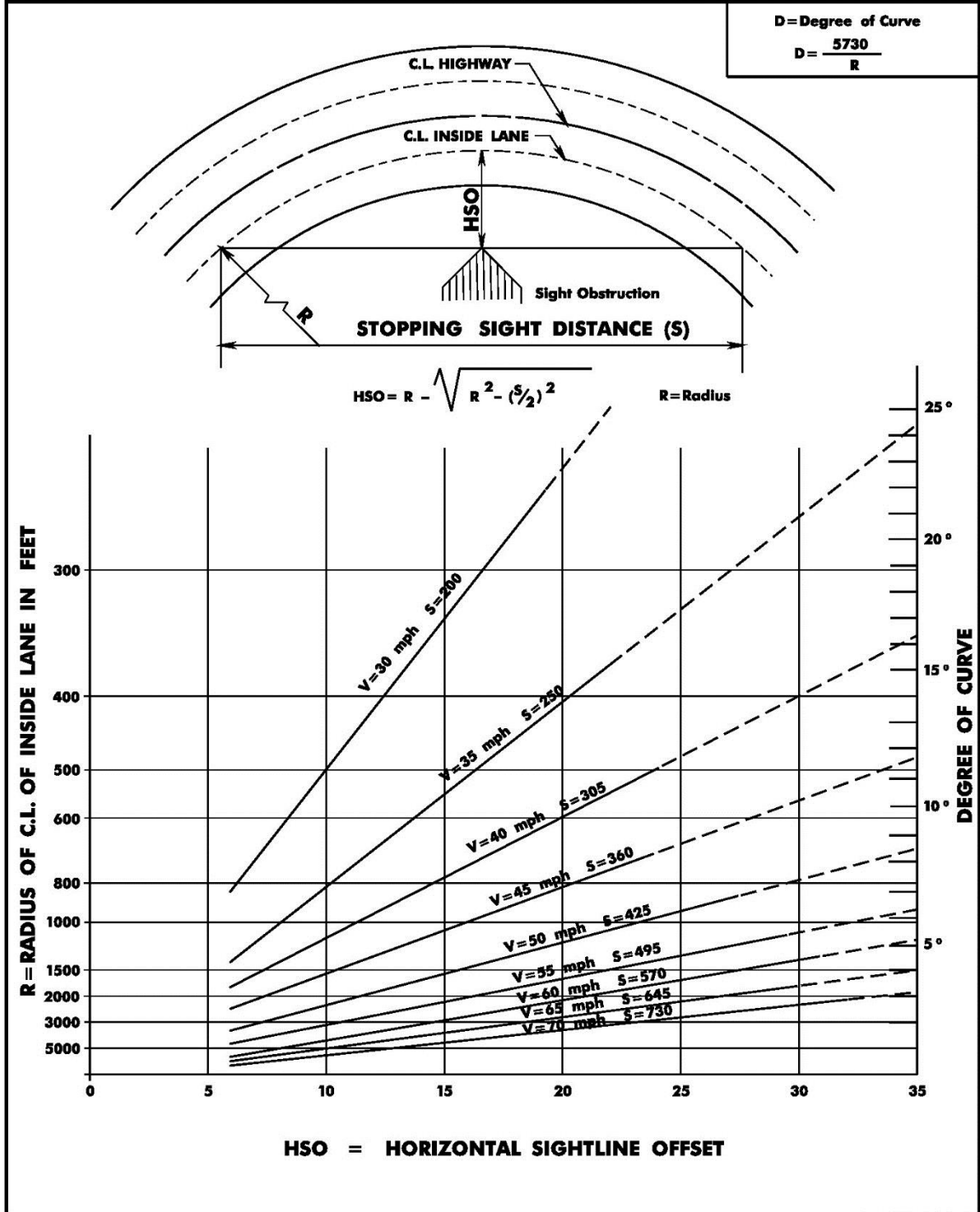
When the required stopping sight distance would not be available because of an obstruction such as a railing or a longitudinal barrier, the following alternatives shall be considered: increase the offset to the obstruction, increase the horizontal radius, or do a combination of both. However, any alternative selected should not require the width of the shoulder on the inside of the curve to exceed 12 feet because the potential exists that motorists will use the shoulder in excess of that width as a passing or travel lane. This is especially pertinent where bicyclists can be expected to operate.

When determining the required HSO distance on ramps, the location of the driver's eye is assumed to be positioned 6 feet from the inside edge of pavement on horizontal curves.

The designer is cautioned in using the values from Figure 4-A since the stopping sight distances and HSO are based upon passenger vehicles. The average driver's eye height in large trucks is approximately 120 percent higher than a driver's eye height in a passenger vehicle. However, the required minimum stopping sight distance can be as much as 50 percent greater than the distance required for passenger vehicles. On routes with high percentages (10 percent or more) of truck traffic, the designer should consider providing greater horizontal clearances to vertical sight obstructions to accommodate the greater stopping distances required by large trucks. The approximate HSO required for trucks is 2.5 times the value obtained from Figure 4-A for passenger vehicles.

In designing the roadway to provide a particular stopping sight distance the designer is advised to consider alternatives. A wider sidewalk, shoulder or bike lane increases the sight triangle, see Section 6.3. Curb extensions and parking restrictions allow the driver to see pedestrians and cross traffic more easily.

**FIGURE 4-A:
MINIMUM STOPPING SIGHT DISTANCE ON
HORIZONTAL CURVES**



4.3 Horizontal Alignment

4.3.1 General

In the design of horizontal curves, it is necessary to establish the proper relationship between design speed, curvature and superelevation. Horizontal alignment must afford at least the minimum stopping sight distance for the design speed at all points on the roadway.

The major considerations in horizontal alignment design are: safety, grade, type of facility, design speed, topography and construction cost. In design, safety is always considered, either directly or indirectly. Topography controls both curve radius and design speed to a large extent. The design speed, in turn, controls sight distance, but sight distance must be considered concurrently with topography because it often demands a larger radius than the design speed. All these factors must be balanced to produce an alignment that is safe, economical, in harmony with the natural contour of the land and, at the same time, adequate for the design classification of the roadway or highway.

4.3.2 Superelevation

When a vehicle travels on a horizontal curve, it is forced radially outward by centrifugal force. This effect becomes more pronounced as the radius of the curve is shortened. This is counterbalanced by providing roadway superelevation and by the side friction between the vehicle tires and the surfacing. Safe travel at different speeds depends upon the radius of curvature, the side friction, and the rate of superelevation.

When the standard superelevation for a horizontal curve cannot be met, a design exception will be required. However, the highest practical superelevation should be selected for the horizontal curve design.

Figures 4-B, 4-C and 4-C1 give the design values for each rate of superelevation to be used for various design speeds and radii on mainline curves.

A 6 percent maximum superelevation rate shall be used on rural highways and rural or urban freeways (see Figure 4-B). A 4 percent maximum superelevation rate may be used on high speed urban highways to minimize conflicts with adjacent development and intersecting streets (see Figure 4-C). Low speed urban streets can use a 4 percent (See Figure 4-C) or 6 percent maximum superelevation rate (see Figure 4-C1)

Figure 4-C1 should be used in low speed built up areas. Although superelevation is advantageous for traffic operations, various factors often combine to make its use impractical in low-speed urban areas. These factors include:

- Wide pavement areas,
- The need to meet the grade of adjacent property,
- Surface drainage considerations,
- The desire to maintain low-speed operation, and
- Frequency of cross streets, alleys and driveways

Therefore, horizontal curves on low-speed urban streets are frequently designed without superelevation, sustaining the lateral force solely with side friction.

The 6 percent maximum superelevation rate for low speed urban streets allows for:

1. a higher threshold of driver discomfort than the 6 percent superelevation rate in Figure 4-B, and
2. application with sharper curvature than the 4 percent maximum superelevation rate in Figure 4-C.

In Figures 4-B, 4-C and 4-C1, Normal Crown (NC) is the traveled way cross section used on curves that are so flat that the elimination of adverse cross slope is not needed. Therefore the normal cross slope section can be used, which is a minimum 1.5 percent. Remove Adverse Crown (RC) are curves where the adverse cross slope should be eliminated by superelevating the entire roadway at the normal cross slope rate. RC is the minimum radii for a computed superelevation rate of 2.0 percent. For curve radii falling between NC and RC, a plane slope across the entire pavement equal to the normal cross slope should typically be used. A transition from the normal crown to a straight-line cross slope will be needed.

On flat radius curves requiring superelevation ranging from 1.5 percent to 2.0 percent, the superelevation should be increased by 0.5 percent in each successive pair of lanes on the low side of the superelevation when more than two lanes are superelevated in the same direction.

It may be appropriate to provide adverse crown (normal crown) on flat radius curves (less than 2 percent superelevation) to avoid water buildup on the low side of the superelevation when there are more than three lanes draining across the pavement. This design treatment would require a design exception where RC is required. Another option is to construct a permeable surface course or a high macotexture surface course since these surfaces appear to have the highest potential for reducing hydroplaning accidents. Also, grooving the pavement perpendicular to the traveled way may be considered as a corrective measure for severe localized hydroplaning problems.

FIGURE 4-B: VALUES OF SUPERELEVATION FOR RURAL HIGHWAYS AND RURAL OR URBAN FREEWAY

Note: Use of $e_{max} = 4\%$ should be limited to urban conditions

e	V_d	V_d	V_d	V_d	V_d	V_d	V_d	V_d	V_d	V_d	V_d
(%)	25 mph	30 mph	35 mph	40 mph	45 mph	50 mph	55 mph	60 mph	65 mph	70 mph	75 mph
	R (ft)	R (ft)	R (ft)	R (ft)	R (ft)	R (ft)	R (ft)	R (ft)	R (ft)	R (ft)	R (ft)
N.C.	2290	3130	4100	5230	6480	7870	9410	11100	12600	14100	15700
R.C.	1630	2240	2950	3770	4680	5700	6820	8060	9130	10300	11500
2.2	1450	2000	2630	3370	4190	5100	6110	7230	8200	9240	10400
2.4	1300	1790	2360	3030	3770	4600	5520	6540	7430	8380	9420
2.6	1170	1610	2130	2740	3420	4170	5020	5950	6770	7660	8620
2.8	1050	1460	1930	2490	3110	3800	4580	5440	6200	7030	7630
3.0	944	1320	1760	2270	2840	3480	4200	4990	5710	6490	7330
3.2	850	1200	1600	2080	2600	3200	3860	4600	5280	6010	6810
3.4	761	1080	1460	1900	2390	2940	3560	4250	4890	5580	6340
3.6	673	972	1320	1740	2190	2710	3290	3940	4540	5210	5930
3.8	583	864	1190	1590	2010	2490	3040	3650	4230	4860	5560
4.0	511	766	1070	1440	1840	2300	2810	3390	3950	4550	5220
4.2	452	684	960	1310	1680	2110	2590	3140	3630	4270	4910
4.4	402	615	868	1190	1540	1940	2400	2920	3440	4010	4630
4.6	360	555	788	1090	1410	1780	2210	2710	3220	3770	4380
4.8	324	502	718	995	1300	1640	2050	2510	3000	3550	4140
5.0	292	4566	654	911	1190	1510	1890	2330	2800	3330	3910
5.2	264	413	595	833	1090	1390	1750	2160	2610	3120	3690
5.4	237	373	540	759	995	1280	1610	1990	2420	2910	3460
5.6	212	335	487	687	903	1160	1470	1830	2230	2700	3230
5.8	186	296	431	611	806	1040	1320	1650	2020	2460	2970
6.0	144	231	340	485	643	833	1060	1330	1660	2040	2500

REV. DATE: MARCH 28, 2015

FIGURE 4-C: VALUES OF SUPERELEVATION FOR URBAN HIGHWAYS

Note: Use of $e_{max} = 4\%$ should be limited to urban conditions

e (%)	$V_d =$ 25mph R (ft)	$V_d =$ 30mph R (ft)	$V_d =$ 35mph R (ft)	$V_d =$ 40mph R (ft)	$V_d =$ 45mph R (ft)	$V_d =$ 50mph R (ft)	$V_d =$ 55mph R (ft)	$V_d =$ 60mph R (ft)
N.C.	2050	2830	3730	4770	5930	7220	8650	10300
R.C.	1340	1880	2490	3220	4040	4940	5950	7080
2.2	1110	1580	2120	2760	3480	4280	5180	6190
2.4	838	1270	1760	2340	2980	3690	4500	5410
2.6	650	1000	1420	1930	2490	3130	3870	4700
2.8	524	817	1170	1620	2100	2660	3310	4060
3.0	433	681	983	1370	1800	2290	2860	3530
3.2	363	576	835	1180	1550	1980	2490	3090
3.4	307	490	714	1010	1340	1720	2170	2700
3.6	259	416	610	865	1150	1480	1880	2350
3.8	215	348	512	730	970	1260	1600	2010
4.0	154	250	371	533	711	926	1190	1500

REV. DATE: APRIL 5, 2018

**FIGURE 4-C1:
VALUES OF SUPERELEVATION FOR LOW-SPEED
URBAN STREETS IN BUILT-UP AREAS**

e (%)	$V_d =$ 25mph R (ft)	$V_d =$ 30mph R (ft)	$V_d =$ 35mph R (ft)	$V_d =$ 40mph R (ft)	$V_d =$ 45mph R (ft)
-2.6	204	345	530	796	1089
-2.4	202	341	524	784	1071
-2.2	200	337	517	773	1055
-2.0	198	333	510	762	1039
-1.5	194	324	495	736	1000
0	181	300	454	667	900
N.C.	170	279	419	610	818
R.C.	167	273	408	593	794
2.2	165	270	404	586	785
2.4	164	268	400	580	776
2.6	163	265	396	573	767
2.8	161	263	393	567	758
3.0	160	261	389	561	750
3.2	159	259	385	556	742
3.4	158	256	382	550	734
3.6	157	254	378	544	726
3.8	155	252	375	539	718
4.0	154	250	371	533	711
4.2	153	248	368	528	703
4.4	152	246	365	523	696
4.6	151	244	361	518	689
4.8	150	242	358	513	682
5.0	149	240	355	508	675
5.2	148	238	352	503	668
5.4	147	236	349	498	662
5.6	146	234	346	494	655
5.8	145	233	343	489	649
6.0	144	231	340	485	643

NOTES:

1. COMPUTED USING SUPERELEVATION DISTRIBUTION METHOD 2.
2. SUPERELEVATION MAY BE OPTIONAL ON LOW-SPEED URBAN STREETS.
3. NEGATIVE SUPERELEVATION VALUES BEYOND - 2.0 % SHOULD BE USED FOR LOW TYPE SURFACES SUCH AS GRAVEL, CRUSHED STONE, AND EARTH. HOWEVER, AREAS WITH INTENSE RAINFALL MAY USE NORMAL CROSS SLOPES ON HIGH TYPE SURFACES OF -2.5%.

REV. DATE: MARCH 23, 2016

A. Axis of Rotation

1. Undivided Highways

For undivided highways, the axis of rotation for superelevation is usually the centerline of the traveled way. However, in special cases where curves are preceded by long, relatively level tangents, the plane of superelevation may be rotated about the inside edge of the pavement to improve perception of the curve. In flat terrain, drainage pockets caused by superelevation may be avoided by changing the axis of rotation from the centerline to the inside edge of the pavement.

2. Ramps and Freeway to Freeway Connections

The axis of rotation may be about either edge of pavement or centerline if multi-lane. Appearance and drainage considerations should always be taken into account in selection of the axis rotation.

3. Divided Highways

a. Freeways

Where the initial median width is 30 feet or less, the axis of rotation should be at the median centerline.

Where the initial median width is greater than 30 feet and the ultimate median width is 30 feet or less, the axis of rotation should be at the median centerline, except where the resulting initial median slope would be steeper than 10H:1V. In the latter case, the axis of rotation should be at the ultimate median edges of pavement.

Where the ultimate median width is greater than 30 feet, the axis of rotation should be at the proposed median edges of pavement.

To avoid a sawtooth on bridges with decked medians, the axis of rotation, if not already on the median centerline, should be shifted to the median centerline.

b. Other Divided Highways

The axis of rotation should be considered on an individual project basis and the most appropriate case for the conditions should be selected.

The selection of the axis of rotation should always be considered in conjunction with the design of the profile and superelevation transition.

B. Superelevation Transition

The superelevation transition consists of the superelevation runoff (length of roadway needed to accomplish the change in outside-lane cross slope from zero to full superelevation or vice versa) and tangent runout (length of roadway needed to accomplish the change in outside-lane cross slope from the normal cross slope to zero or vice versa). The definition of and method of deriving superelevation runoff and runout in this manual is the same as described in AASHTO, *"A Policy on Geometric Design of Highways and Streets."*

The superelevation transition should be designed to satisfy the requirements of safety and comfort and be pleasing in appearance. The minimum length of superelevation runoff and runout should be based on the following formula:

Superelevation Runoff

$$L_r = (w)(n)(e)(b)/\Delta$$

Where:

- L_r = minimum length of
superelevation runoff, ft;
 Δ = maximum relative gradient,
percent (Table 4-2);
 n = number of lanes rotated
 b = adjustment factor for
number of lanes rotated
(Table 4-3)
 w = width of one traffic lane, ft.
 e = design superelevation rate,
percent

Tangent Runout

$$L_t = (L_r)[(e_{NC})/e]$$

Where

- L_t = minimum length of tangent
runout, ft.
 e_{NC} = normal cross slope rate,
percent
 e = design superelevation rate
 L_r = minimum length of
superelevation runoff, ft.

Table 4-2
Maximum Relative Gradient

Design Speed (mph)	25	30	35	40	45	50	55	60	65	70
Maximum Relative Gradient	0.70	0.66	0.62	0.58	0.54	0.50	0.47	0.45	0.43	0.40

Table 4-3
Adjustment Factor for Number of Lanes Rotated

Number of Lanes Rotated (n)	Adjustment Factor (b)
1	1.00
1.5	0.83
2	0.75
2.5	0.70
3	0.67
3.5	0.64

On 3R projects where the existing runoff and runout lengths are shorter than calculated from the formula, the existing runoff and runout lengths may be maintained.

With respect to the beginning or ending of a curve, the amount of runoff on the tangent should desirably be based on Table 4-4. However, runoff lengths on the tangent ranging from 60 to 90 percent are acceptable.

**Table 4-4
Percent of Runoff on Tangent**

Design Speed Mph	Portion of runoff located prior to the curve			
	Number of lanes rotated			
	1.0	1.5	2.0-2.5	3.0-3.5
25-45	0.80	0.85	0.90	0.90
50-80	0.70	0.75	0.80	0.85

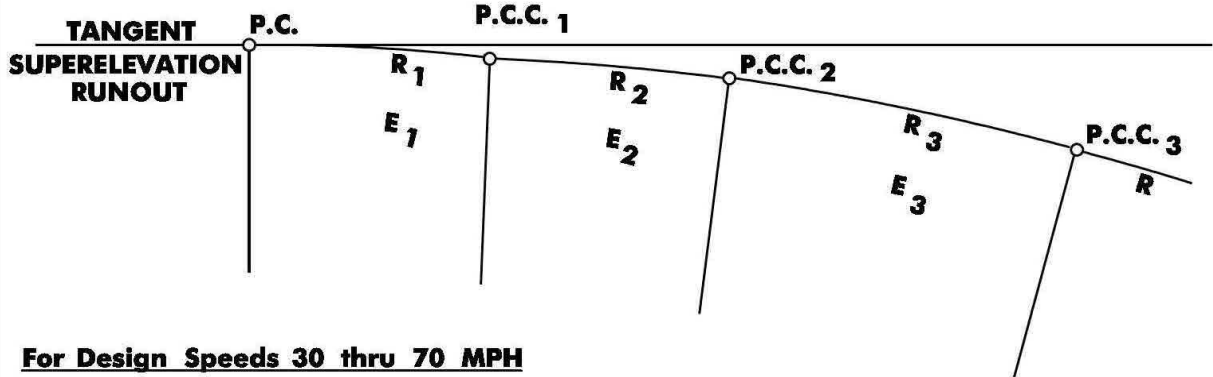
After a superelevation transition is designed, profiles of the edges of pavement and shoulder should be plotted and irregularities removed by introducing smooth curves by the means of a graphic profile. Flat areas which are undesirable from a drainage standpoint should be avoided.

Pronounced and unsightly sags may develop on the low side of the superelevation. These can be corrected by adjusting the grades on the two edges of pavement throughout the curve.

C. Transition Curves and Superelevation

The use of transition curves on arterial highways designed for 50 mph or greater is encouraged. Figures 4D through 4H inclusive indicate the desirable treatment on highway curves including the method of distributing superelevation.

**FIGURE 4-D:
TRANSITION CURVES**



For Design Speeds 30 thru 70 MPH

1. Determine if radii transition is needed for radius R using chart below. Transition curves not essential when radius is greater than:

Superelevation	30 MPH	35 MPH	40 MPH	45 MPH	50 MPH	55 MPH	60 MPH	70 MPH
6% Superelevation for rural hways & rural or urban fwys	1400	2100	2900	3300	3800	4800	5700	7600
4% Superelevation for urban highways	1000	1300	1600	2300	2900	3300	3800	NA

2. If required, use standard Transition Curves.
3. At P.C.C.₃ hold maximum E for radius R.
4. Using superelevation chart, determine if superelevation is needed for R₁.
5. If superelevation is needed for R₁, use 2/3 maximum superelevation for R₁ at P.C.
6. Distribute superelevation evenly between P.C.C.₃ and P.C.
7. Distribute superelevation at the same rate as in step 6 on tangent up to normal section. However, this superelevation transition may be reduced to 2%/sec. in certain locations, such as on short tangents between reverse curves or on a crest or sag vertical curve.

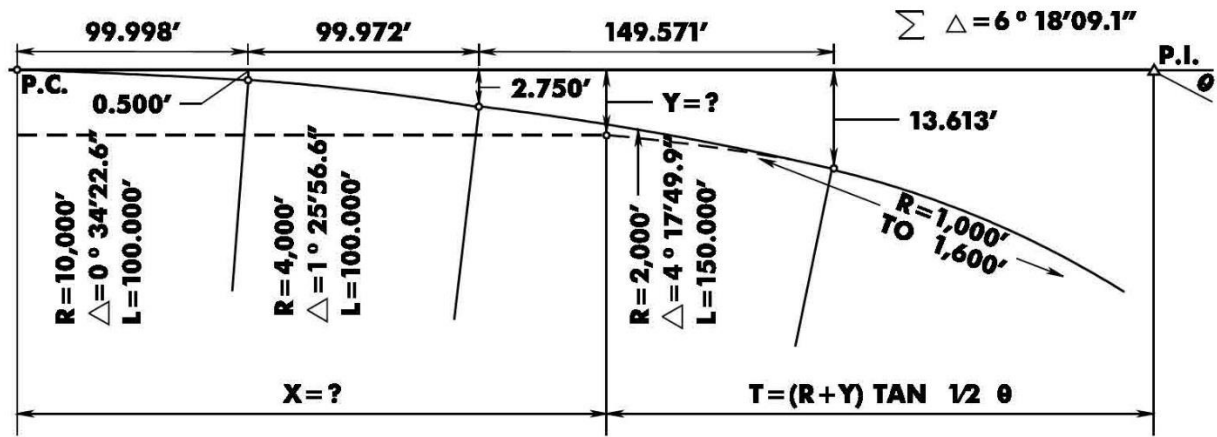
On Existing Roadways Or Where Radii Transitions Can Not Be Provided

1. Determine maximum superelevation needed for radius (R).
2. Use 2/3 maximum superelevation at P.C. and P.T. of curve.
3. Distribute superelevation at a maximum rate of 2%/sec.

REV. DATE: JUNE 30, 2015

FIGURE 4-E: TRANSITION CURVES

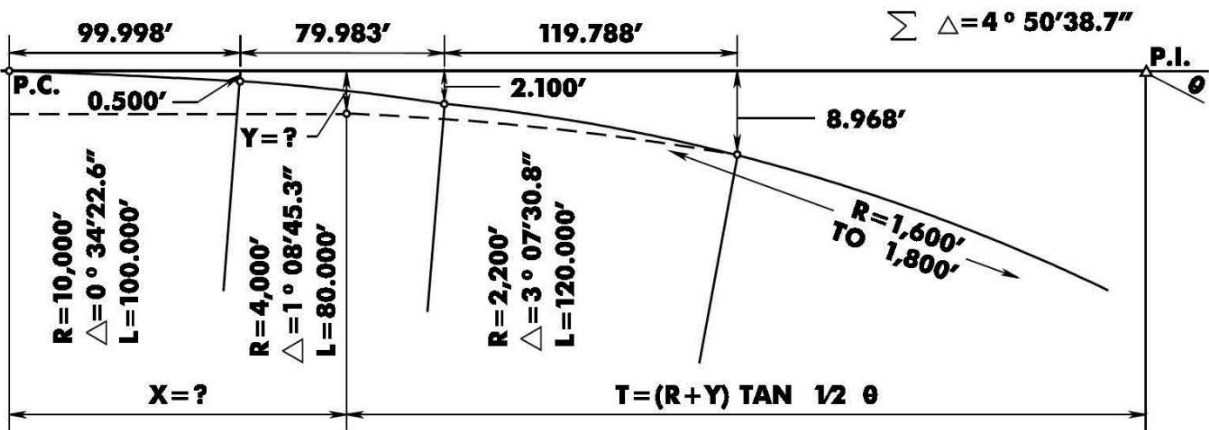
1,000' TO 1,600' RADIUS



$$X = 349.5413 - 0.1097783008 R$$

$$Y = 13.6127 - 0.0060439020 R$$

1,600' TO 1,800' RADIUS



$$X = 299.7694 - 0.0844447697 R$$

$$Y = 8.9680 - 0.0035718386 R$$

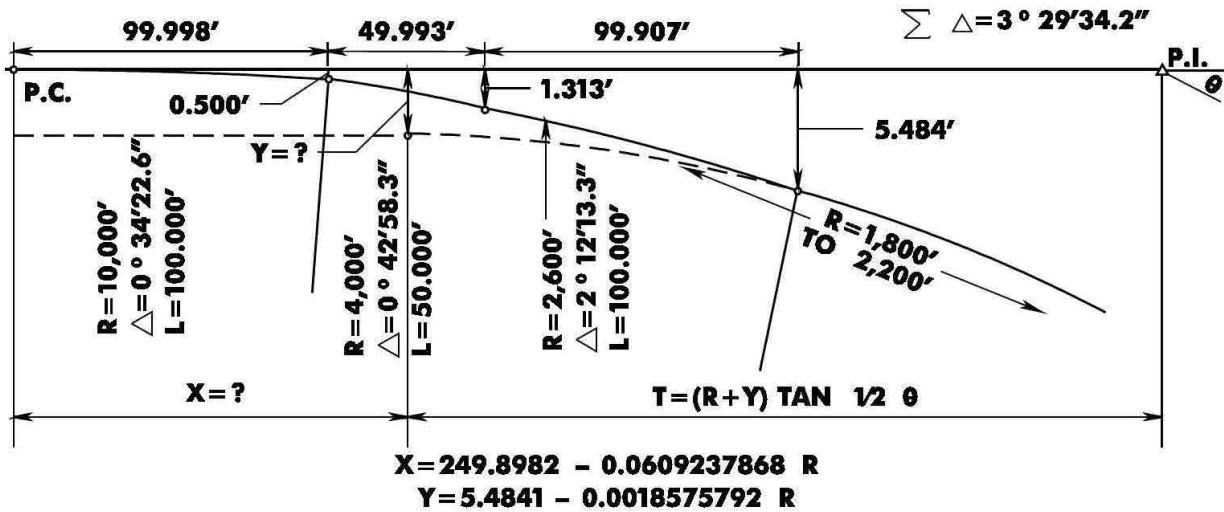
NOTE: To Locate Transition P.C.:

- (1) Find X and Y for desired radius
- (2) Add radius R to Y distance
- (3) Find T for R and Y
- (4) Add T to X for distance P.C. to P.I.

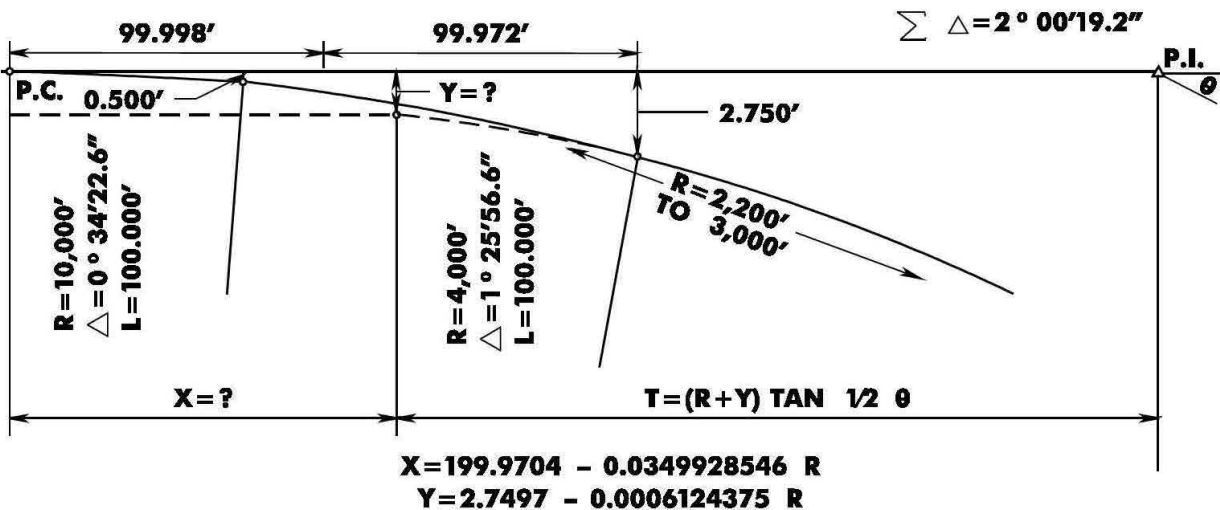
REV. DATE: JUNE 30, 2015

FIGURE 4-F: TRANSITION CURVES

1,800' TO 2,200' RADIUS



2,200' TO 3,000' RADIUS



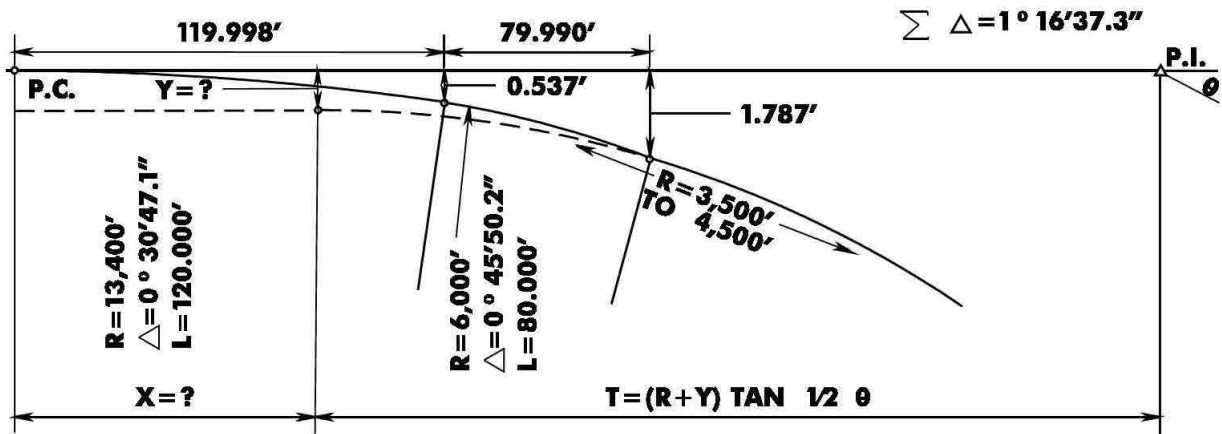
NOTE: To Locate Transition P.C.:

- (1) Find X and Y for desired radius
- (2) Add radius R to Y distance
- (3) Find T for R and Y
- (4) Add T to X for distance P.C. to P.I.

REV. DATE: JUNE 30, 2016

FIGURE 4-G: TRANSITION CURVES

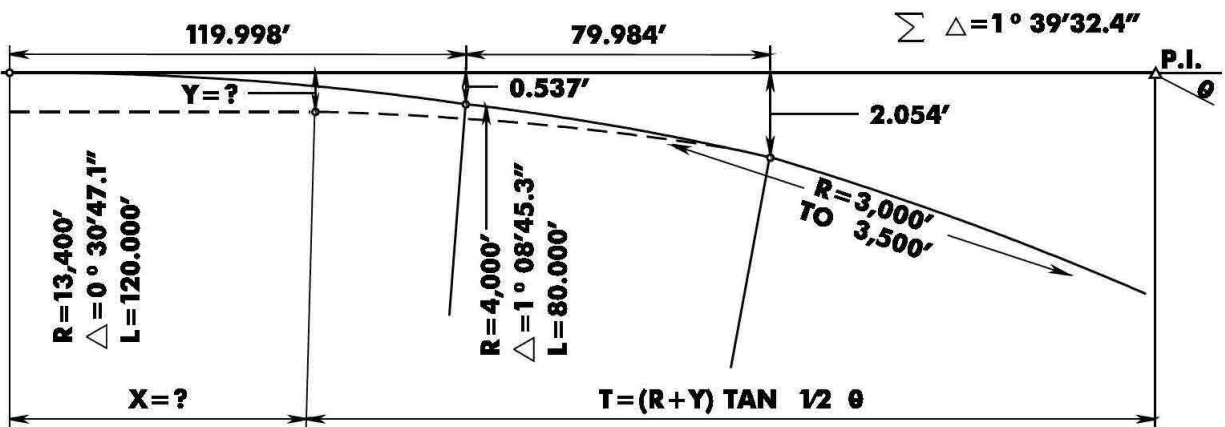
3,500' TO 4,500' RADIUS



$$X = 199.9880 - 0.0222867118 R$$

$$Y = 1.7870 - 0.0002483796 R$$

3,000' TO 3,500' RADIUS



$$X = 199.9827 - 0.0289511780 R$$

$$Y = 2.0536 - 0.0004191732 R$$

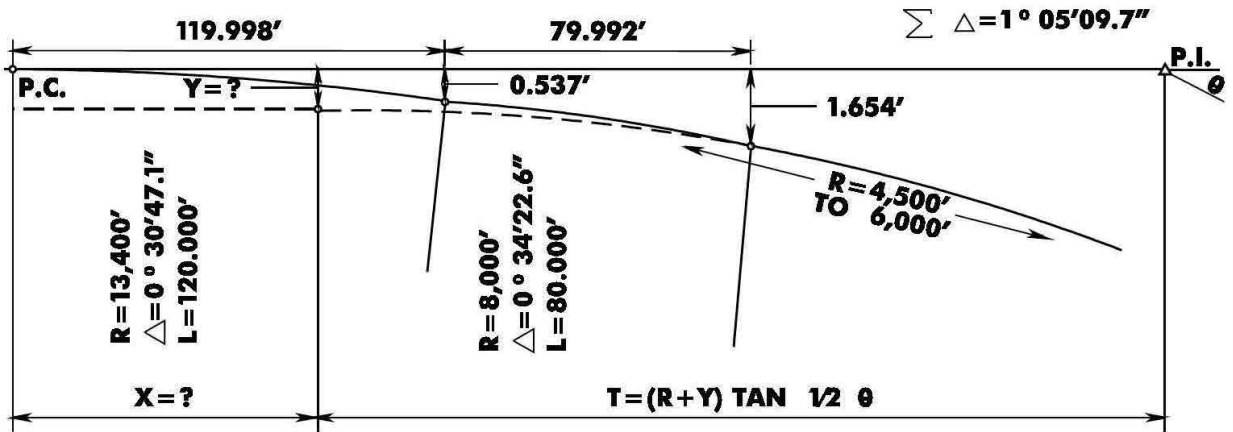
NOTE: To Locate Transition P.C.:

- (1) Find X and Y for desired radius
- (2) Add radius R to Y distance
- (3) Find T for R and Y
- (4) Add T to X for distance P.C. to P.I.

REV. DATE: JUNE 30, 2015

FIGURE 4-H: TRANSITION CURVES

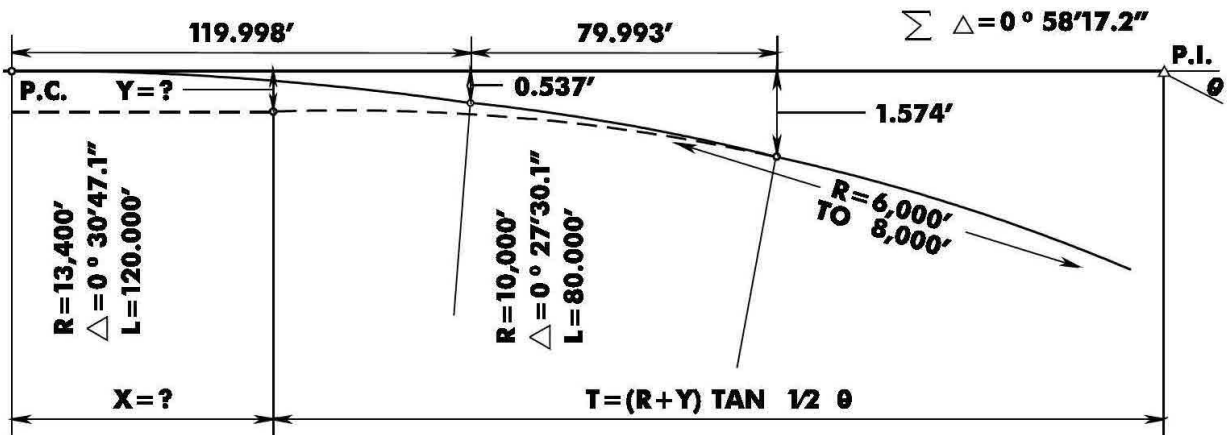
4,500' TO 6,000' RADIUS



$$X = 199.9903 - 0.0189540888 R$$

$$Y = 1.6537 - 0.0001796449 R$$

6,000' TO 8,000' RADIUS



$$X = 199.9915 - 0.0169544115 R$$

$$Y = 1.5737 - 0.0001437364 R$$

NOTE: To Locate Transition P.C.:

- (1) Find X and Y for desired radius
- (2) Add radius R to Y distance
- (3) Find T for R and Y
- (4) Add T to X for distance P.C. to P.I.

REV. DATE: JUNE 30, 2016

4.3.3 Curvature

A General

The changes in direction along a highway are basically accounted for by simple curves or compound curves. Excessive curvature or poor combinations of curvature generate accidents, limit capacity, cause economic losses in time and operating costs, and detract from a pleasing appearance. To avoid these poor design practices, the following general controls should be used.

B. Curve Radii for Horizontal Curves

Table 4-5 gives the minimum radius of open highway curves for specific design speeds. This table is based upon a 6 percent and 4 percent maximum superelevation; it ignores the horizontal stopping sight distance factor.

**Table 4-5
Standards for Curve Radius**

Design Speed (mph)	Minimum Radius of Curve for Rural Highways and Rural or Urban Freeways Based on 6% e_{max}	Minimum Radius of Curve for Urban Highways Based on 4% e_{max}	Minimum Radius of Curve for Low Speed Urban Highways Based on 6% e_{max}
	(ft)	(ft)	(ft)
25	144	154	144
30	231	250	231
35	340	371	340
40	485	533	485
45	643	711	---
50	833	926	---
55	1060	1190	---
60	1330	1500	---
65	1660	---	---
70	2040	---	---

Every effort should be made to exceed the minimum values. Minimum radii should be used only when the cost or other adverse effects of realizing a higher standard are inconsistent with the benefits. Where a longitudinal barrier is provided in the median, the above minimum radii may need to be increased or the adjacent shoulder widened to provide adequate horizontal stopping sight distance.

The suggested minimum radius for a freeway is 3000 feet in rural areas and 1600 feet and 2400 feet for design speeds of 60 mph and 70 mph respectively in urban areas. For a land service highway, the preferred minimum radius is 1600 feet and 1000 feet for design speeds of 60 mph and 50 mph respectively.

Due to the higher center of gravity on large trucks, sharp curves on open highways may contribute to truck overturning. Overturning becomes critical on radii below approximately 700 feet. Where new or reconstructed curves on open highways with radii less than 700 feet must be provided, the design of these radii shall be based upon a design speed of at least 10 mph greater than the anticipated posted speed.

C. Alignment Consistency

Sudden reductions in standards introduce the element of surprise to the driver and should be avoided. Where physical restrictions on curve radius cannot be overcome and it becomes necessary to introduce curvature of a lower standard than the design speed for the project, the design speed between successive curves shall change not more than 10 mph. Introduction of a curve for a design speed lower than the design speed of the project shall be avoided at the end of a long tangent or at other locations where high approach speeds may be anticipated.

D. Stopping Sight Distance

Horizontal alignment should afford at least the desirable stopping sight distance for the design speed at all points of the highway. Where social, environmental or economic impacts do not permit the use of desirable values, lesser stopping sight distances may be used, but shall not be less than the minimum values.

E. Curve Length and Central Angle

Desirably, the minimum curve length for central angles less than 5 degrees should be 500 feet long, and the minimum length should be increased 100 feet for each 1 degree decrease in the central angle to avoid the appearance of a kink. For central angles smaller than 30 minutes, no curve is required. In no event shall sight distance or other safety considerations be sacrificed to meet the above requirement.

F. Compound Curves

On compound curves for arterial highways, the curve treatment shown in Figures 4D through 4H should be used. For compound curves at intersections and ramps, the ratio of the flatter radius to the sharper radius should not exceed 2.0.

G. Reversing Curves

The intervening tangent distance between reverse curves should, as a minimum, be sufficient to accommodate the superelevation transition as specified in Section 4.3.2, "Superelevation." For design speeds of 50 mph and greater, longer tangent lengths are desirable. A range of desirable tangent lengths are shown in Table 4-6 for high design speeds.

**Table 4-6
Desirable Tangent Length
Between Reversing Curves**

Design Speed (mph)	Desirable Tangent (ft)
50	500-600
60	600-800
70	800-1000

H. Broken Back Curves

A broken back curve consists of two curves in the same direction joined by a short tangent. Broken back curves are unsightly and violate driver expectancy. A reasonable additional expenditure may be warranted to avoid such curvature.

The intervening tangent distance between broken back curves should, as a minimum, be sufficient to accommodate the superelevation transition as specified in Section 4.3.2. For design speeds of 50 mph and greater, longer tangent lengths are desirable. Table 4-7 indicates the desirable tangent length between same direction curves. The desirable tangent distance should be exceeded when both curves are visible for some distance ahead.

**Table 4-7
Desirable Tangent Length
Between Same Direction Curves**

Design Speed (mph)	Desirable Tangent (ft)
50	1000
60	1500
70	2500

I. Alignment at Bridges

Superelevation transitions on bridges almost always result in an unsightly appearance of the bridge and the bridge railing. Therefore, if at all possible, horizontal curves should begin and end a sufficient distance from the bridge so that no part of the superelevation transition extends onto the bridge. Alignment and safety considerations, however, are paramount and shall not be sacrificed to meet the above criteria.

4.4 Vertical Alignment

4.4.1 General

The profile line is a reference line by which the elevation of the pavement and other features of the highway are established. It is controlled mainly by topography, type of highway, horizontal alignment, safety, sight distance, construction costs, cultural development, drainage and pleasing appearance. The performance of heavy vehicles on a grade must also be considered.

All portions of the profile line must meet sight distance requirements for the design speed of the road.

In flat terrain, the elevation of the profile line is often controlled by drainage considerations. In rolling terrain, some undulation in the profile line is often advantageous, both from the standpoint of truck operation and construction economy. But, this should be done with appearance in mind; for example, a profile on tangent alignment exhibiting a series of humps visible for some distance ahead should be avoided whenever possible. In rolling terrain, however, the profile usually is closely dependent upon physical controls.

In considering alternative profiles, economic comparisons should be made. For further details, see AASHTO, *"A Policy on Geometric Design of Highways and Streets."*

4.4.2 Position with Respect to Cross Section

The profile line should generally coincide with the axis of rotation for superelevation. The relation to the cross section should be as follows:

A. Undivided Highways

The profile line should coincide with the highway centerline.

B. Ramps and Freeway to Freeway Connections

The profile line may be positioned at either edge of pavement, or centerline of ramp if multi-lane.

C. Divided Highways

The profile line may be positioned at either the centerline of the median or at the median edge of pavement. The former case is appropriate for paved medians 30 feet wide or less. The latter case is appropriate when:

1. The median edges of pavement of the two roadways are at equal elevation.
2. The two roadways are at different elevations.

4.4.3 Separate Grade Lines

Separate or independent profile lines are appropriate in some cases for freeways and divided arterial highways.

They are not normally considered appropriate where medians are less than 30 feet. Exceptions to this may be minor differences between opposing grade lines in special situations.

In addition, appreciable grade differentials between roadbeds should be avoided in the vicinity of at-grade intersections. For traffic entering from the crossroad, confusion and wrong-way movements could result if the pavement of the far roadway is obscured due to an excessive differential.

4.4.4 Standards for Grade

The minimum grade rate for freeways and land service highways with a curbed or bermed section is 0.3 percent. On highways with an umbrella section, grades flatter than 0.3 percent may be used where the shoulder width is 8 feet or greater and the shoulder cross slope is 4 percent or greater. For maximum grades for urban and rural land service highways and freeways, see Table 4-8.

**Table 4-8
Maximum Grades (%)**

Rural Land Service Highways

Type of Terrain	Design Speed (mph)						
	30	40	45	50	55	60	65
Level	---	5	5	4	4	3	3
Rolling	---	6	6	5	5	4	4
Mountainous	---	8	7	7	6	6	5

Urban Land Service Highways

Type of Terrain	Design Speed (mph)						
	30	40	45	50	55	60	65
Level	8	7	6	6	5	5	---
Rolling	9	8	7	7	6	6	---
Mountainous	11	10	9	9	8	8	---

Freeways *

Type of Terrain	Design Speed (mph)						
	40	45	50	55	60	65	70
Level	---	---	4	4	3	3	3
Rolling	---	---	5	5	4	4	4
Mountainous	---	---	6	6	6	5	5

- * Grades 1% steeper than the value shown may be provided in mountainous terrain or in urban areas with crucial right-of-way controls.

4.4.5 Vertical Curves

Properly designed vertical curves should provide adequate sight distance, safety, comfortable driving, good drainage, and pleasing appearance. On new alignments or major reconstruction projects on existing highways, the designer should, where practical, provide the desirable vertical curve lengths. The use of minimum vertical curve lengths should be limited to existing highways and those locations where the desirable values or values greater than the minimum would involve significant social, environmental or economic impacts.

A parabolic vertical curve is used to provide a smooth transition between different tangent grades. Figures 4-I and 4-J give the length of crest and sag vertical curves for various design speeds and algebraic differences in grade. The stopping sight distance for these curves are based upon a height of eye of 3.5 feet, and a height of object of 2 feet. The minimum length of vertical curve shall be determined by the formulas in

Figures 4I and 4J. The minimum desirable length of vertical curve may also be obtained by multiplying the K value (Fig. 4-I or 4-J) by the algebraic difference in grade. The vertical lines in Figure 4-I and 4-J are equivalent to 3 times the design speed. To determine the length of crest vertical curves on highways designed with two-way left-turn lanes (see Section 6.7.1).

Flat vertical curves may develop poor drainage at level sections. Highway drainage must be given more careful consideration when the design speed exceeds 60 and 65 mph for crest vertical curves and sag vertical curves respectively. The length of sag vertical curves for riding comfort should desirably be approximately equal to:

$$L = AV^2/46.5.$$

L = Length of sag vertical curve, ft.

A = Algebraic difference in grades, percent.

V = Design speed, mph.

When the difference between the P.V.I. elevation and the vertical curve elevation at the P.V.I. station (E) is 0.0625 feet (3/4 inch), a vertical curve is not required. The use of a profile angle point is permitted. The maximum algebraic difference in tangent grades (A) that an angle point is permitted for various design speeds is shown in Table 4-9. This table is based on a length of vertical curve of 3 times the design speed.

**Table 4-9
Use of a Profile Angle Point**

Design Speed (mph)	A_{MAX} %
25	.70
30	.55
35	.50
40	.40
45	.40
50	.35
55	.30
60	.30
65	.25
70	.25

All umbrella section low points in cut and fill sections on freeways and Interstate highways shall be provided with slope protection at each low point in the mainline or ramp vertical geometry as shown in the "*Standard Roadway Construction Details.*" The purpose of this treatment is to minimize maintenance requirements in addressing the gradual buildup of a berm which may eventually contribute to water ponding on the roadway surface and/or erosion of the side slope. The following are some recommended low point treatments:

A. Low Point at Edge of Ramp or Outside Edge of Mainline Pavement

Where practical, an "E" inlet should be provided in the outside edge of pavement at the low point to catch and divert the surface runoff. Provide outlet protection where needed at the pipe outfall.

As an alternative, provide slope protection which shall consist of the following:

1. Fill Section

Slope protection shall consist of a 20 feet long bituminous concrete paved area between the edge of pavement and the hinge point (PVI) together with a riprap stone flume on the fill slope and a riprap stone apron at the bottom of the slope. The riprap shall only be provided where the fill slope is steeper than 4H:1V. Where there is an inlet in a swale at the low point, center the riprap stone apron around the inlet. Where guide rail exists at the low point, the 10 foot long paved area shall be constructed instead of the non-vegetative surface treatment under the guide rail.

2. Cut Section

Slope protection shall consist of a 20 foot long bituminous concrete paved area between the edge of pavement and the toe of slope.

3. Low Point at Median Edge of Mainline Pavement

Provide slope protection which shall consist of a 20 foot long by 5 foot wide strip of bituminous concrete pavement adjacent to the inside edge of shoulder. If the fill slope is steeper than 4H:1V, provide riprap stone slope protection as described in "Low Point at Edge of Ramp or Outside Edge of Mainline Pavement".

On two-lane roads, extremely long crest vertical curves over one half mile should be avoided, since many drivers refuse to pass on such curves, despite adequate sight distance. It is sometimes more economical to use four-lane construction, than to obtain passing sight distance by the use of a long vertical curve.

Vertical curves affect intersection sight distance, therefore, utilizing the distances in Figure 6-A, an eye height of 3.5 feet and an object height of 3.5 feet; check for vertical sight distance at the intersection.

Broken back vertical curves consist of two vertical curves in the same direction, separated by a short grade tangent. A profile with such curvature normally should be avoided.

4.4.6 Heavy Grades

Except on level terrain, often it is not economically feasible to design a profile that will allow uniform operating speeds for all classes of vehicles. Sometimes, a long sustained gradient is unavoidable.

From a truck operation standpoint, a profile with sections of maximum gradient broken by length of flatter grade is preferable to a long sustained grade only slightly below the maximum allowable. It is considered good practice to use the steeper rates at the bottom of the grade, thus developing slack for lighter gradient at the top or elsewhere on the grade.

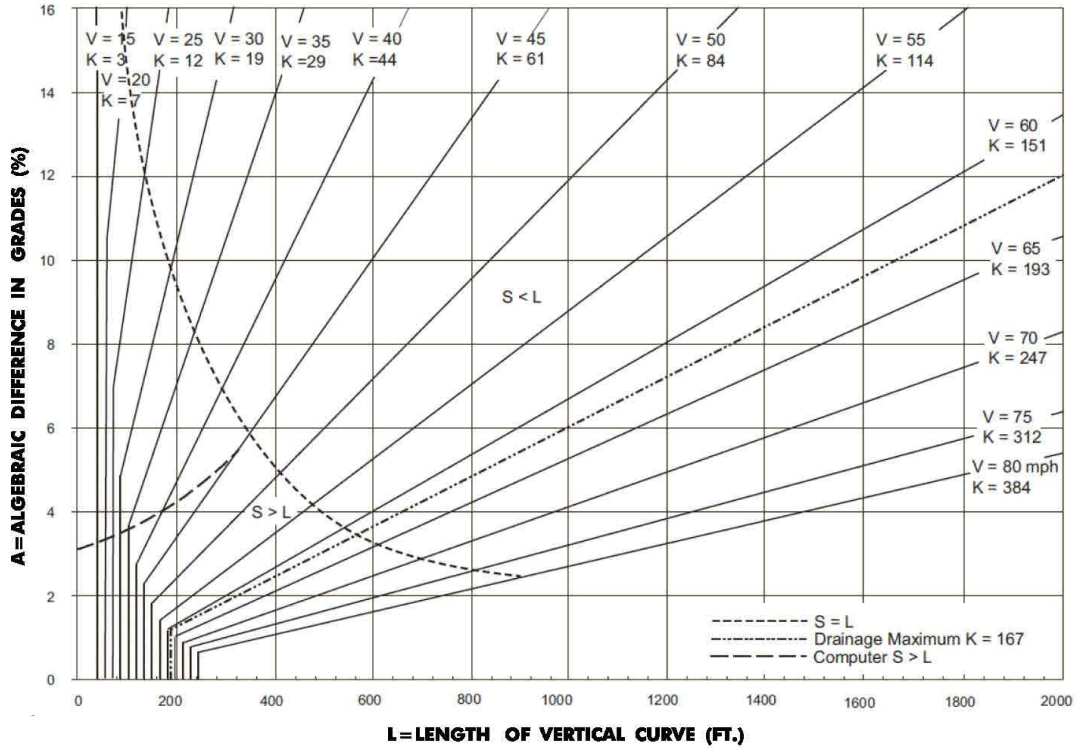
4.4.7 Coordination with Horizontal Alignment

A proper balance between curvature and grades should be sought. When possible, vertical curves should be superimposed on horizontal curves. This reduces the number of sight distance restrictions on the project, makes changes in profile less apparent, particularly in rolling terrain, and results in a pleasing appearance. For safety reasons, the horizontal curve should lead the vertical curve. On the other hand, where the change in horizontal alignment at a grade summit is slight, it safely may be concealed by making the vertical curve overlay the horizontal curve.

When vertical and horizontal curves are thus superimposed, the superelevation may cause distortion in the outer pavement edges. Profiles of the pavement edge should be plotted and smooth curves introduced to remove any irregularities.

A sharp horizontal curve should not be introduced at or near a pronounced summit or grade sag. This presents a distorted appearance and is particularly hazardous at night.

**FIGURE 4-1:
DESIGN CONTROLS FOR CREST VERTICAL CURVES**



NOTE: Drainage of the Roadway on CREST Vertical Curves must be more carefully designed when the Design Speed exceeds 60 MPH.

When S is greater than L, $L = 2S - \frac{2158}{A}$

When S is less than L, $L = \frac{AS^2}{2158}$

V = Design Speed

S = Stopping Sight Distance, Feet

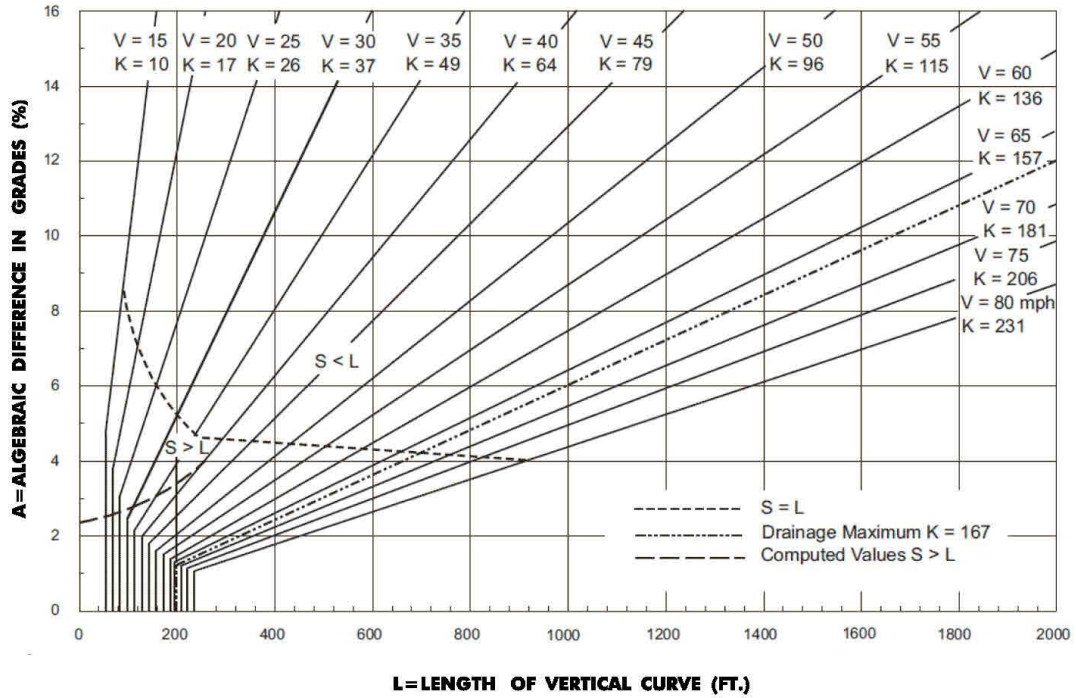
A = Algebraic Difference In Tangent Grades, Percent

K = Horizontal Distance Required To Effect A Percent Change In Gradient, Feet

L = KA

REV. DATE: MARCH 23, 2016

**FIGURE 4-J:
DESIGN CONTROLS FOR SAG VERTICAL CURVES**



NOTE: Drainage of the Roadway on SAG Vertical Curves must be more carefully designed when the Design Speed exceeds 65 MPH.

When S is greater than L, $L = 2S - \frac{400 + 3.5S}{A}$

When S is less than L, $L = \frac{AS^2}{400 + 3.5S}$

V=Design Speed

S=Light Beam Distance, Feet

A=Algebraic Difference In Tangent Grades, Percent

K=Horizontal Distance Required To Effect A Percent Change In Gradient, Feet

L=KA

REV. DATE: MARCH 28, 2016

4.5 Climbing Lane

A climbing lane, as shown in Figure 4-K, is an auxiliary lane introduced at the beginning of a sustained positive grade for the diversion of slow traffic.

Generally, climbing lanes will be provided when the following conditions are satisfied. These conditions could be waived if slower moving truck traffic was the major contributing factor causing a high accident rate and could be corrected by addition of a climbing lane.

A. Two-Lane Highways

The following three conditions should be satisfied to justify a climbing lane:

1. Upgrade traffic flow rate in excess of 200 vehicles per hour.
2. Upgrade truck flow rate in excess of 20 vehicles per hour.
3. **One** of the following conditions exists:
 - a. A 10 mph or greater speed reduction is expected for a typical heavy truck.
 - b. Level of Service E or F exists on the grade.
 - c. A reduction of two or more levels of service is experienced when moving from the approach segment of the grade.

A complete explanation and a sample calculation on how to check for these conditions are shown in the section on "Climbing Lanes" contained in Chapter 3, "Elements of Design", of the AASHTO, *"A Policy on Geometric Design of Highways and Streets."*

B. Freeways and Multi-lane Highways

Both of the following conditions should be satisfied to justify a climbing lane:

1. A 10 mph or greater speed reduction is expected for a typical heavy truck.
2. The service volume on an individual grade should not exceed that attained by using the next poorer level of service from that used for the basic design. The one exception is that the service volume derived from employing Level of Service D should not be exceeded.

If the analysis indicates that a climbing lane is required, an additional check must be made to determine if the number of lanes required on the grade are sufficient even with a climbing lane.

A complete explanation and a sample calculation on how to check for these conditions are shown in the section on "Climbing Lanes" contained in Chapter 3, "Elements of Design", of the AASHTO, *"A Policy on Geometric Design of Highways and Streets."*

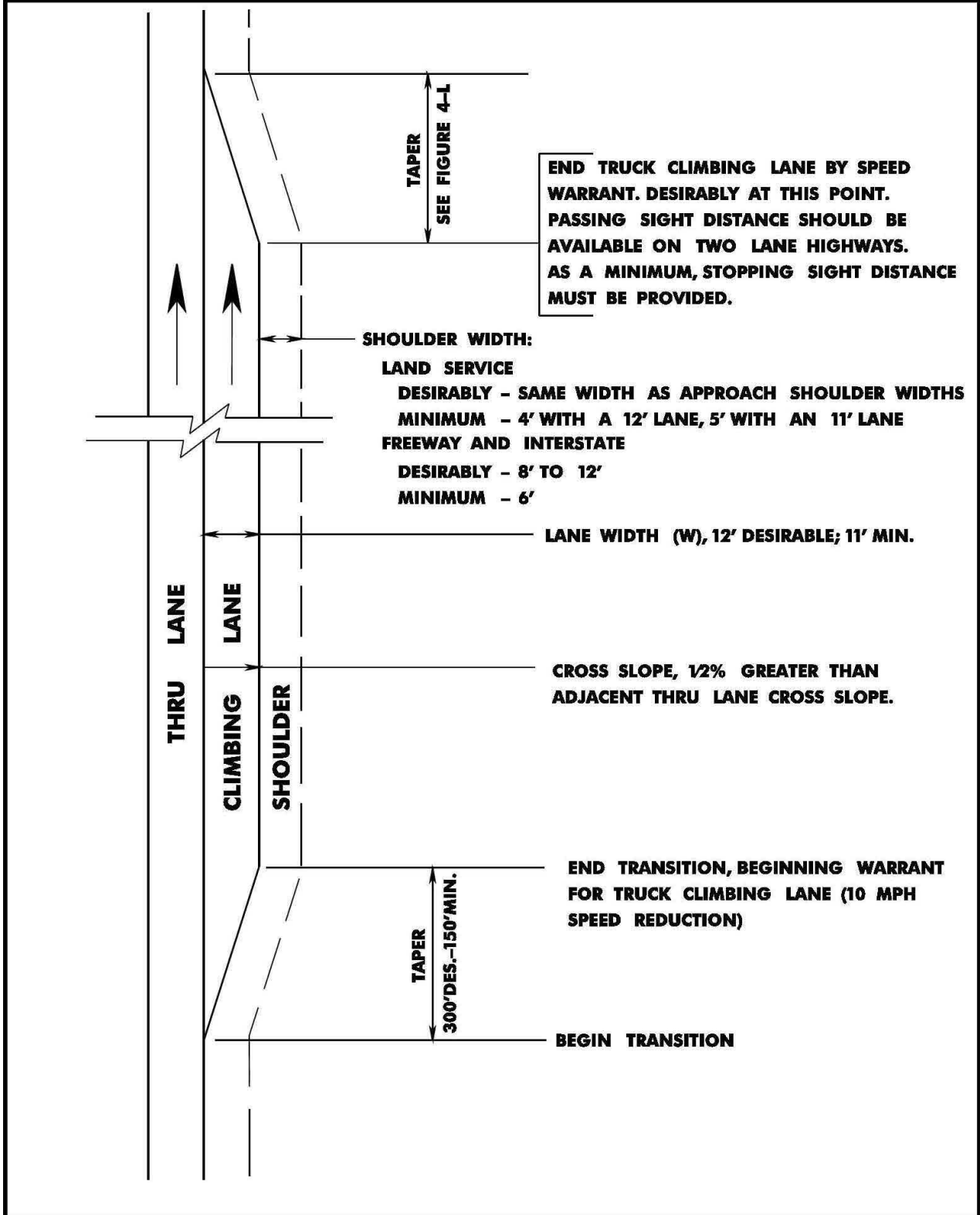
The beginning warrant for a truck climbing lane shall be that point where truck operating speed is reduced by 10 mph. To locate this point, use Figure 3-28 or Figure 3-29 of the aforementioned AASHTO Policy, depending on the weight/horsepower ratio of the appropriate truck. The beginning of the climbing lane should be preceded by a tapered section, desirably 300 feet, however, a 150 foot minimum taper may be used.

Desirably, the point of ending of a climbing lane would be to a point beyond the crest, where a typical truck could attain a speed that is about 10 mph below the operating speed of the highway. This point can be determined from Figure 3-29 of the

aforementioned AASHTO Policy. If it is not practical to end the climbing lane as per Figure 3-29, end the climbing lane at a point where the truck has proper sight distance to safely merge into the normal lane, or preferably, 200 feet beyond this point. For two lane highways, passing sight distance should be available. For freeways and multi-lane highways, passing sight distance need not be considered. For all highways, as a minimum, stopping sight distance shall be available. The ending taper beyond this point shall be according to Figure 4-L.

A distance-speed profile should be developed for the area of a climbing lane. The profile should start at the bottom of the first long downgrade prior to the upgrade being considered for a climbing lane, speeds through long vertical curves can be approximated by considering 25 percent of the vertical curve length (chord) as part of the grade under question.

**FIGURE 4-K:
CLIMBING LANE**



REV. DATE: JUNE '90, 2015

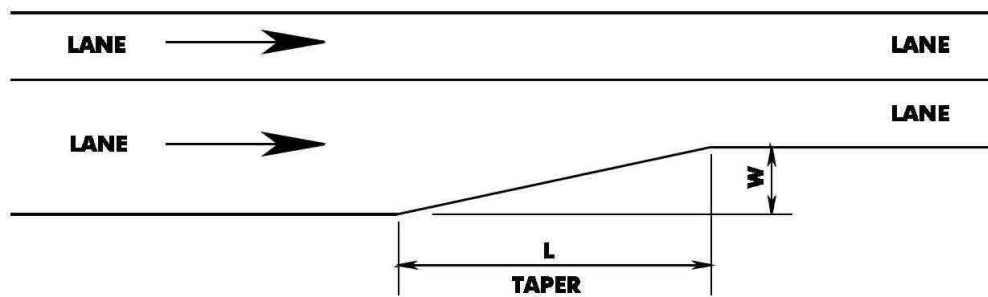
4.6 Through Lane Transition

Design standards of the various features of the transition between roadways of different widths should be consistent with the design standards of the superior roadway. The transition for a lane drop or lane width reduction should be made on a tangent section whenever possible and should avoid locations with horizontal and vertical sight distance restrictions. Whenever feasible, the entire transition should be visible to the driver of a vehicle approaching the narrower section.

The design should be such that at-grade intersections within the transition are avoided.

Figure 4-L shows the minimum required taper length based upon the design speed of the roadway. In all cases, a taper length longer than the minimum should be provided where possible. In general, when a lane is dropped by tapering, the transition should be on the right so that traffic merges to the left.

FIGURE 4-L: THROUGH LANE TRANSITION



**FOR DESIGN SPEEDS GREATER THAN
45 MPH, $L = VW$.**

**V = DESIGN SPEED (MPH)
W = LANE WIDTH REDUCTION (FT.)
L = TAPER LENGTH (FT.)**

**FOR DESIGN SPEEDS EQUAL TO OR LESS
THAN 45 MPH, $L = \frac{V^2 W}{60}$**

REV. DATE: JUNE 30, 2015

Section 5 - Major Cross Section Elements

5.1 General

The major cross section elements considered in the design of streets and highways include the pavement surface type, cross slope, lane widths, shoulders, roadside or border, curbs, sidewalks, driveways, and medians. Due consideration should be given to the motoring and non-motoring users in designing the cross section.

5.2 Pavement

5.2.1 Surface Type

Pavement surface type is determined by soil conditions, traffic volume, traffic composition, material availability, initial cost, and the extent and cost of maintenance. All of these affect the relationship of cost to traffic service.

Generally, all roadways in the State are surfaced with hot mix asphalt materials or Portland cement concrete. These pavements provide good riding qualities, help to maintain the cross section, and adequately support the expected volume and weights of vehicles without failure due to fatigue. In considering cyclists and pedestrian traffic, other roadway surfaces include textured and colored asphalt, textured and colored concrete, and brick and other unit pavers. As part of urban design, landscape or streetscape treatments, these are used in crosswalks, bike lanes, shoulders, and traffic calming devices.

Important characteristics in relation to geometric design are the ability of a surface to sustain its shape and dimensions, the ability to drain, and the effect on driver, bicyclist, and pedestrian behavior.

5.2.2 Cross Slope

The cross slope of the pavement is the slope of the pavement surface measured transverse to the centerline of the highway. The high point of a normal cross slope of a roadway is known as the crown. Undivided pavements on tangents or on flat curves have a high point (crown) in the middle of the traveled way and slope downward toward both edges.

The minimum cross slope for concrete pavement and hot mix asphalt pavement should be 1.5 percent. The cross slope shall be uniform across the pavement section, from the high point to the edge of lane. The cross slope in each successive lane should be increased by 0.5 percent. However, it may be increased on each successive pair of lanes by 0.5 to 1 percent in order to cause the least disturbance to the existing border area, to limit the amount of resurfacing weight on a structure, or to minimize the cross slope in the outer lane when more than three lanes are sloped in the same direction.

In addition, if the cross slope of the left-turn lane is in the same direction as the adjacent lane, the adjacent lane cross slope may be used.

On a divided highway, each one way pavement may be crowned separately, as on a two lane highway, or it may have a unidirectional slope across the entire width of pavement, which is almost always downward to the outer edge.

A cross section where each roadway has a separate high point (crown) has an advantage of rapidly draining the pavement as shown in the top two drawings of Figure 5-A. In addition, the difference between high and low points in the cross section is kept to a minimum. The disadvantage is, additional drainage inlets and subsurface drainage lines are required. In addition, treatments of at grade intersections are more difficult because of the creation of several high and low points on the cross section. Preferably, use of such sections should be limited to regions of high rainfall. A cross section having no curbing and a wide depressed median are particularly well suited for high rainfall conditions.

Roadways that slope only in one direction provide more comfort to drivers because vehicles tend to be pulled in the same direction when changing lanes (As shown in the bottom four drawings of Figure 5-A). Roadways with a unidirectional slope may drain away from or toward the median. Providing drainage away from the median may affect a savings in drainage structures and simplify treatment of intersecting streets. Advantages of drainage toward the median are:

1. An economical drainage system, in that all surface runoff is collected into a single conduit.
2. Outer lanes, used by most traffic, are freer of surface water.

A major disadvantage of drainage toward the median is all the pavement drainage must pass over the inner, higher speed lanes. Where curbed medians exist, the drainage is concentrated next to and on higher speed lanes. This concentration of drainage, when the median is narrow, results in annoying and undesirable splashing onto the windshields of opposing traffic.

The rate of cross slope on curves as well as on tangent alignment is an important element in cross section design. See Section 4, "Basic Geometric Design Elements," for speed curvature relationships to determine pavement superelevation on curves.

5.3 Lane Widths

Lane widths have a great influence on driving safety and comfort. The predominant lane width on freeways and land service highways is 12 feet.

While lane widths of 12 feet are desirable on land service highways, circumstances may necessitate the use of lanes less than 12 feet. Lane widths of 11 feet in urban areas are acceptable. Existing lane widths of 10 feet have been provided in certain locations where right of way and existing development became stringent controls and where truck volumes were limited. However, new or reconstructed 10 foot wide lanes would not be proposed today, except in traffic calming areas.

On land service highways, where it is not practical to provide a shoulder adjacent to the outside lane (design exception required), the outside lane width shall be 15 feet to accommodate bicyclists. Where alternate bike access is provided, the outside lane

width should be 1 foot wider than the adjacent through lane width. The designer should strive to accommodate the bicyclist and pedestrian on all projects.

When resurfacing existing highways that have lane widths of 10 feet or less, the existing lanes should be widened to either 11 foot minimum or 12 foot desirable.

Auxiliary lanes at intersections are often provided to facilitate traffic movements. Such lanes should be equal in width to the through lanes but not less than 10 foot wide when constructed adjacent to a shoulder. When there is no right shoulder adjacent to a new or reconstructed auxiliary lane, the width of the auxiliary lane shall be designed to accommodate the bicyclist (no design exception required). Where alternate bike access is provided, the auxiliary lane width should be 1 foot wider than the adjacent through lane width. The criteria in this paragraph shall also apply to auxiliary lanes at interchanges on land service highways.

On Interstates and freeways, the width of the auxiliary lane shall be 12 feet. Lane widths for specific types of highways are enumerated as part of the typical sections illustrated at the end of this section.

For the width of climbing lanes and left-turn lanes, see Section 4, "Basic Geometric Design Elements" and Section 6, "At-Grade Intersections," respectively.

5.4 Shoulders

5.4.1 General

A shoulder is the portion of the roadway contiguous with the traveled way for accommodation of stopped vehicles, for emergency use, and for lateral support of subbase, base and surface courses.

Some of the more important advantages of providing shoulders are:

1. Space for the motorist to pull completely off the roadway for emergencies.
2. An escape zone to allow motorists to avoid potential accidents or reduce accident severity.
3. An aid to driver comforts by creating a sense of openness; improves highway capacity.
4. An improvement in sight distance in cut sections.
5. A provision to enhance lateral clearance for the placement of signs, guide rails, or other roadside appurtenances.
6. Space for pedestrians where there is no sidewalk and for bicycle usage.

New Jersey shoulder pavement design is based on the following engineering considerations.

- A. The New Jersey state highway system constitutes the heart of our state's surface transportation network. As a corridor state, the New Jersey highway system is subjected to the highest traffic count and loading in the nation.

- B. New Jersey highways continue to be faced with a serious backlog of deficient pavements in poor to fair condition. As such, many of the pavements are in the process of or will eventually be rehabilitated or reconstructed.
- C. Due to frequent traffic encroachment over the longitudinal joints next to the shoulder and the need to stage traffic on shoulders during rehabilitation, progressive shoulder deterioration will result if adequate shoulder pavement strength is not provided in the original construction.
- D. Shoulders of adequate pavement strength will carry traffic during the future construction of additional lanes, and the widening, resurfacing, rehabilitation and recycling of the existing lanes. The shoulders will also be used as an additional riding lane during peak hours relieving traffic congestion, such as in the case of "bus/shoulder" lanes.

The following shoulder pavement design policy is based on the above consideration. The term "Full Pavement Shoulder" is a shoulder pavement equal to that of the mainline pavement.

Full pavement shoulders shall be used as follows:

Full pavement shoulders shall be used for all new construction, reconstruction and widening on all portions of the NJ highway system.

For mainline pavement rehabilitation projects, shoulder pavement shall be designed to carry mainline traffic for a minimum period of 2 years or the following minimum section (whichever is greater):

2" Hot Mix Asphalt ___ Surface Course

3" Hot Mix Asphalt ___ Intermediate Course

8" Dense Graded Aggregate Base Course

5.4.2 Width of Shoulders

Desirably, a vehicle stopped on the right shoulder should clear the pavement edge by at least 1 foot, preferably by 2 feet. On land service highways, in difficult terrain, or in areas where right of way is restricted due to roadside development or environmental factors, a minimum 8 foot wide shoulder may be provided. On 3R projects, the existing shoulder width may be reduced to 8 feet to provide wider lanes. New or reconstructed shoulders on heavily traveled and high speed land service highways, especially those carrying large numbers of trucks (250 DHV), where turning volumes are high or dualization is anticipated, should have usable shoulders at least 10 feet and preferably 12 feet wide. Shoulders should be provided adjacent to all new acceleration and deceleration lanes at interchanges, where practical, in major new construction or reconstruction projects along major land service highways having an AADT of 10,500 per lane (DHV of 1,500 per lane) or greater, for the project design year. "Practical" is defined as given consideration to social, economic, and environmental impacts in concert with safe and overall efficient traffic operations.

Shoulder widths on freeways and Interstate highways shall be 10 feet minimum. However, where truck traffic exceeds 250 DDHV, a 12 foot shoulder should be

provided. A 10 foot shoulder shall be provided adjacent to all new or reconstructed auxiliary lanes. Where no right shoulder exists, the existing auxiliary lane width may be maintained on Interstate and freeway resurfacing, restoration and rehabilitation (3R) projects. However, whenever practical, a 10 foot desirable or a 6 foot minimum shoulder should be provided on Interstate and freeway 3R projects.

Shoulder widths for specific types of highways are enumerated as part of the typical sections illustrated at the end of this section.

Although it is desirable that a shoulder be wide enough for a vehicle to be driven completely off the traveled way, narrower shoulders are better than none at all. Partial shoulders are sometimes used when full shoulders are unduly costly, as on long span bridges or in mountainous terrain. Regardless of the width, a shoulder should be continuous where feasible.

Left shoulders are preferred on all divided highways. The desirable median shoulder width on a 4 lane and 6 to 8 lane highway is 5 feet and 10 feet respectively. The minimum left shoulder width on land service highways is 3 feet and on a freeway is 4 feet.

Shoulders on structures should have the same width as the usable shoulders on the approach roadways, both right and left. This design is essential on freeways, and is desirable on all arterials where shoulders are provided. Long span, high cost structures usually warrant detailed special studies to determine feasible dimensions. Wherever practicable, full shoulders should be included, but as has been indicated, for some cases, it may be judged proper to use only partial width shoulders.

5.4.3 Cross Slope

Shoulders are important links in the lateral drainage systems. A shoulder should be flush with the roadway surface and abut the edge of the through lane/auxiliary lane. On a divided highway with a depressed median, all shoulders should be sloped to drain away from the traveled way. With a raised narrow median, the median shoulder may slope in the same direction as the traveled way. All shoulders should be pitched sufficiently to rapidly drain surface water.

Desirably, a shoulder cross slope should not be less than 4 percent to minimize ponding on the roadway. As a minimum, a shoulder cross slope should not be less than 2 percent. However, when a left shoulder is less than 5 feet in width and the median slopes away from the roadway or where the median and adjacent lane both slope toward the median gutter, the shoulder cross slope may be at the same rate and direction as the adjacent lane for ease of construction.

On 3R and reconstruction projects, shoulder cross slope may be increased to 6 percent to minimize impacts on existing curb, drainage, adjacent properties, access, etc. But, shoulder cross slope should not exceed 5 percent where a curb ramp is present since the angle of incidence between a mobility device descending a curb ramp and the counter slope of the gutter must be limited to avoid catching the mobility device, e.g. wheelchair footrest.

Shoulder on the high side of a superelevated section should be designed to drain away from the adjacent traffic lanes. A shoulder cross slope that drains away from the

paved surface on the high side of a superelevated section should be designed to avoid too great a cross slope break. The cross slope of the shoulder shall be as follows:

1. The shoulder cross slope should be 4 percent where the superelevation rate is 3 percent or less.
2. For superelevation rates greater than 3 percent and less than 5 percent, a maximum rollover rate of 7 percent will be used to establish the shoulder cross slope.
3. When superelevation rates range from 5 percent to 6 percent, the shoulder cross slope will be 2 percent.

On an existing superelevated curve where there is a history of run off the road accidents, the location should be evaluated for proper clear zone, sight distance, superelevation, and signing. The shoulder cross slope on the outside of the curve may be constructed in the same direction as the adjacent lane. However, consideration should be given to snow storage in border area (snow melting in border area then draining and refreezing on roadway surface) by sloping the border away from roadway or by providing slotted drainage along shoulder.

The shoulder on the inside of a curve or on the low side of a superelevated section should be sloped at 4 percent, or equal to the superelevation of the adjacent lane, whichever is greater.

5.4.4 Intermittent Shoulders or Turnouts

It will not always be economically feasible to provide desirably wide shoulders continuously along the highway through high cut areas or along steep mountainsides. In such cases, consideration should be given to the use of intermittent sections of shoulders or turnouts that can be placed at favorable locations along the highway. Where intermittent shoulders or turnouts are provided, the length of the transition section should be approximately 50 feet to encourage usage and to permit safe entry and exit.

5.5 Roadside or Border

5.5.1 General

The area between the roadway and the highway right of way is referred to as the roadside or border. The term "roadside" generally applies to freeways and the term "border" applies to land service highways. The distance between the outside edge of roadway and the hinge point may be less than the width of the roadside or border area.

5.5.2 Width

The right-of-way width on rural and urban freeways is typically 300 feet and 150 feet respectively. Depending upon the median, traveled way and shoulder widths, the roadside width is in the range of 70 feet for rural freeways and 25 feet for urban freeways.

Desirably, the width of the border should be sufficient to permit the placement of utility poles and all fixed obstructions beyond the clear zone area. Normally an additional 5 feet should be added to the clear zone distance to provide the necessary placement of the utilities within the highway right-of-way yet beyond the clear zone recovery area. The acquisition of additional right-of-way should be considered if it is economically and socially feasible. If right-of-way is acquired, it should accommodate all current project needs and any foreseeable future widening.

See Section 8 for the required clear zone distance for various design speeds.

When it is not practical to provide for the clear zone width, a border width on land service highways of 15 feet is preferred. The designer should determine the practical border width by taking into account pedestrian needs, bicyclist needs and the proper placement of roadside appurtenances such as longitudinal barriers, longitudinal barrier end treatments, utility poles, signal pole foundations, signs and foundations, existing and/or future sidewalks, underground utilities, etc. A border width would typically range from 10 feet to 15 feet on land service highways. The border can be adjusted more or less on a property by property basis. In order to avoid obstacles and preclude unnecessary right-of-way acquisitions, the border width may be reduced at spot locations or random length sections. For example, you may want to reduce the 15 feet proposed border on one property to a 12 feet border in order to avoid a parking lot or a building. These reduced border areas will need to provide for safe and feasible accommodations of all roadside appurtenances.

The goal should be to provide the optimum border width considering all project costs, such as construction, utilities, permits, design, right-of-way, etc.

5.5.3 Fencing

For freeways, interstates and expressways continuous fencing should be included in order to effectively preserve access control. Chain link fence as per the Standard Construction Details and Standard Specifications should be used. If another type of fence is required, it should be the most cost-effective type suited to the specific adjacent land use. Fencing should be located on either the right-of-way or access-control line, unless it has been established that such fencing is not necessary in order to effectively preserve access control. Engineering judgment should dictate exceptions in areas of precipitous slopes or natural barriers. However, in addition to vehicular access control, pedestrian or animal movements should also be considered. For additional fence design criteria, refer to Subsection 5.9.3, Median Fencing on Land Service Highways, Subsection 10.8.9, Fence Positioning at Culverts and Head Walls and Subsection 10.11.4E, Stormwater Management Facility Design Features (basin fencing policy).

5.6 Curbing

5.6.1 General

The type and location of curbing appreciably affects driver behavior, which affects the safety and utility of a highway. Curbing may be used to separate pedestrian walkways from the roadway, to control drainage and to control ingress and egress from roadside development. Where required, curbing may be permitted at intersections for

channelization or for sustaining the integrity of pavement (ex: curb at intersection radius returns). To fit the definition of "curb," some raised aspect or vertical element is required. Curbing is not a substitute for pavement markings.

Curb is used extensively on urban land service highways. However, on rural land service highways, caution should be exercised in the use of curb. In the interest of safety, new installations of vertical curb shall not be constructed on freeways and Interstate highways; however, sloping curb may be used for drainage control.

5.6.2 Types of Curb

The two general classes of curb are vertical curb and sloping curb. Each may be designed as a separate unit, or integrally with the pavement. Vertical and sloping curb may be designed with a gutter to form a combination curb and gutter section.

Sloping curb is designed to allow an errant vehicle to cross it readily without further loss of vehicular control. It is low with a flat sloping face. On a land service highway, sloping curb can be used at the median edge to discourage a vehicle from illegally crossing a grass median or to outline channelizing islands in intersection areas. Sloping curb may also be provided at the outer edge of the shoulder. It is the preferred treatment for left-turn slots. Sloping curb permits a vehicle with large off-tracking to have a less damaging effect to both vehicle and curb. However, vertical curb may be used on left-turn slots where there is existing vertical curb in the median.

Vertical curb and a safety walk may be desirable along the faces of long walls, bridges, and tunnels, particularly if full shoulders are not provided.

New installation of vertical curb shall not be constructed on freeways and Interstate highways; and are considered undesirable on other high speed arterials. When accidentally struck at high speeds, it is difficult for the operator to retain control of the vehicle. In addition, most vertical curbs are not adequate to prevent a vehicle from leaving the roadway. Where positive protection is required such as along a long narrow median or adjacent to a bridge substructure, suitable median barrier or guide rail should be provided.

Generally, vertical curb should not be provided inside the face of bridge parapets. A preferred and more widely used method is to design the parapet in the shape of the Department's concrete barrier curb. On an urban street, vertical curb may be used on bridges with the same curb height as the approach roadway curb. Inlets should be provided in the gutter or the curb, or both.

Generally, it is not practical to design a gutter section to contain all of the runoff, even from frequent rains, and some overflow onto the traveled surface can be expected. The spread of water on the traveled way is kept within tolerable limits by the proper spacing of inlets. Grate inlets and depressions or curb opening inlets should not be placed in the travel lane because of their adverse effect on drivers and bicycle riders who veer away from them. Warping of the gutter for curb opening inlets should be limited to the portions within 4 feet of the curb to minimize adverse driving effects. See NJDOT Drainage Design Manual for the proper spacing of inlets.

5.6.3 Placement of Curb

Curb introduced intermittently along a street should be offset 3 feet from the edge of lane if there is no shoulder: where the curb is continuous, the offset should be at least 1 foot. See Figure 6-D for offsets of curbs for islands with and without shoulders.

5.6.4 Curb Height

For new installations of sloping curb, the overall curb height shall not exceed 4 inches.

For new installations of vertical curb, the curb height (face) shall conform to the following:

1. For posted speeds greater than 40 mph, the curb height shall not exceed a 4 inch face.
2. For posted speeds less than or equal to 40 mph, the desirable curb height is 4 inches. Where sidewalks are to be constructed, a 6 inch face may be used.
3. For traffic calming areas a 6 inch face may be used.
4. For curb on bridges with sidewalk, the desirable curb height should be 6 inches to accommodate future resurfacing and/or conduits through the sidewalk.

When curb is used in conjunction with guide rail, see Section 8, "Guide Rail Design and Median Barriers," for the placement of guide rail.

Where posted speeds are 40 mph or less and no guide rail exists, an 8 inch face vertical curb may be used to discourage parking of vehicles in the border area of the highway.

When resurfacing adjacent to curb, the curb should not be removed unless it is deteriorated or the curb face will be reduced to less than 3 inches. A curb face less than 3 inches is permissible, provided drainage calculations indicate the depth of flow in the gutter does not exceed the remaining curb reveal.

When replacing short sections of existing curb or installing short sections of new curb, the curb face should match the adjacent existing curb face. A short section of curb is approximately less than 100 feet long at each location. When there are closely spaced short sections of curb to be replaced, install the entire run of curb at the standard curb height and type as specified above.

5.7 Sidewalk

5.7.1 General

The Americans with Disabilities Act (ADA) of 1990 is a civil rights statute that prohibits discrimination against people with disabilities. Designing and constructing pedestrian facilities in the public right-of-way that are usable by people with disabilities is an important component of highway design.

ADA accessibility provisions apply to the entire transportation project development process including planning, design, construction, and maintenance activities.

The requirements of ADA include:

- New construction must be accessible and usable by persons with disabilities.

- Alterations to existing facilities, within the scope or limits of a project, must provide usability to the extent feasible.

On new roadway construction, roadway rehabilitation, roadway reconstruction, new bridge construction, bridge replacement and bridge widening projects, sidewalk, where feasible, should be provided on both sides of land service highways and structures in urban areas. All of these projects should have some type of walking facility out of the traveled way. A shoulder will provide a safer environment for a pedestrian than walking in the live lane.

Generally, sidewalks will not be provided in rural areas. However, sidewalks shall be considered where there is evidence of heavy pedestrian usage. Sidewalks may be provided to close short gaps in existing sidewalk and where there are major pedestrian traffic generators such as churches, schools, hospitals, public transportation facilities, etc., adjacent to the highway or where there is a worn pedestrian path. A worn path is an indicator of pedestrian traffic that requires a sidewalk. Individuals tend to walk in locations where continuous sidewalk connections are provided. A lack of pedestrian activity in a location with discontinuous sidewalks is therefore not necessarily an indication of a lack of pedestrian demand. Future development should also be considered for possible major traffic generators. Sidewalk should not be constructed along undeveloped land, unless a maintenance jurisdiction agreement or a resolution of support with the municipality can be obtained.

A sidewalk may be omitted from a project where there is insufficient border width or there is no anticipated pedestrian traffic due to the land use adjacent to the roadway.

In order to ensure that sidewalk installations provide satisfactory linkages and contribute to system connectivity, all designers should take the following actions:

1. When project limits are established, continuity of pedestrian travel should be a consideration relating to the ends of the project including addressing arrival and departure curb ramps at pedestrian street crossings. For example: Where resurfacing only the northbound side of a divided highway, and the intersection(s) have sidewalk on both bounds, then curb ramps will be addressed on the entire intersection.

2. Sidewalks should extend to common destinations and logical terminal points.

Sufficient clear zone width, drainage patterns and infrastructure, grade issues, and the presence or future likelihood of bus transit stops are all key considerations of where to install sidewalks. The location of drainage ditches, buildings, retaining walls, utility poles, bus stops, vegetation, and significant roadside grade changes should be carefully coordinated with sidewalk alignment where possible to provide adequate sight distance and separation between pedestrians and vehicular traffic.

In general, sidewalks should be placed within the highway right of way. However, the exact alignment can vary throughout the section and practical considerations should be given to:

- maintaining adequate storm water runoff
- following the 2010 Standards for Titles II and III Facilities: 2004 ADAAG

- designing around roadside features that cannot or should not be removed or relocated. At times, providing for adequate pedestrian and traffic safety and/or pedestrian continuity may warrant locating sidewalks outside of the highway right of way, and within easements.

Note: Where sidewalks are not warranted by existing or latent demand, or cannot be constructed due to right of way, utility, environmental or other considerations, roadway shoulders designed to NJDOT standards should be provided.

On a bridge project in urban and rural areas where there is no existing or proposed sidewalk at the approaches to a structure and the structure is to be replaced or widened, sidewalk may be provided on the new structure where additional width would be required to maintain traffic during future bridge deck reconstruction.

Urban and rural areas shall be those identified in the current State Highway Straight Line Diagrams.

A Complete Street is defined as means to provide safe access for all users by designing and operating a comprehensive, integrated, connected multi-modal network of transportation options, such as sidewalks, bike lanes, paved shoulders, safe crossings and transit amenities. The NJDOT Policy No. 703 implemented a Complete Street policy through the planning, design, construction, maintenance and operation of new and reconstructed transportation facilities enabling safe access and mobility of pedestrians, bicyclists, and transit users, of all ages and abilities. Limited Scope projects are not required to comply with the Complete Streets policy. See Policy No. 703 for more information on how to address Complete Streets on new and reconstruction projects and what qualifies for an exemption.

5.7.2 Pedestrian Needs

Walking is a fundamental form of transportation that should be accommodated on streets and land service highways in New Jersey. The capacity of roadways to accommodate pedestrians safely and efficiently, particularly in urban and developing suburban areas, depends on the availability of sidewalks, intersection and mid-block crossing provisions, and other general characteristics such as roadway width and design speed.

When a sidewalk will be provided only along one side of the highway, the designer should include provisions to accommodate pedestrian crossing of the highway to access the sidewalk if there is a substantiated existing or future need. Such provisions should include one or more of the following: signing, painted cross walks, at grade pedestrian signals, pedestrian overpasses, etc.

Sidewalks should provide a continuous system of safe, accessible pathways for pedestrians. Sidewalks on both sides are desirable for pedestrian-compatible roadways.

5.7.3 Sidewalk Design

Sidewalk Width

The following widths apply in situations of pedestrian traffic typical in suburban, or rural areas, or traditional residential neighborhoods. In urbanized areas, especially downtowns and commercial districts, sidewalk width should be increased to accommodate higher volumes of users. Refer to the Highway Capacity Manual to calculate the desirable sidewalk width given current or projected pedestrian volumes. The designer should consider local input prior to any installation of new sidewalk.

The desirable width of a sidewalk should be 5 feet (4 feet minimum) when separated by a buffer strip. If a sidewalk width less than 5 feet is used, consideration of 5 feet by 5 feet passing areas at 200 feet intervals should be given during the planning and design of the project. The 5 foot width accommodates continuous, two-way pedestrian traffic. Where the border width is 10 feet, the width of the buffer strip should be a minimum of three feet with a 4 feet wide sidewalk. However, where the border width is 15 feet, the minimum width of the buffer strip should desirably be 5 feet with a 5 feet wide sidewalk or 6 feet with a 4 feet wide sidewalk. If the border widths are other than 10 or 15 feet, look at the conditions out in the field to determine the widths of the sidewalk and buffer strip. Where no buffer strip is provided, the desirable width of the sidewalk should be 7 feet (6 feet minimum), especially where there is no shoulder (aids in preventing truck overhangs or side view mirrors from hitting pedestrians). The sidewalk width should be clear of trees, signs, utility poles, raised junction boxes, hydrants, parking meters and other similar appurtenances. Where utility poles, sign supports, fire hydrants, etc., are provided in the sidewalk, the minimum useable width of sidewalk shall be 3 feet to allow for mobility device passage.

On rehabilitation or reconstruction projects where improvements are constrained by the existing border and right-of-way areas, the desirable sidewalk width would be implemented where feasible.

It is recognized that on rehabilitation or reconstruction projects existing roadway elements such as beam guide rail, signs, utility poles, slopes, etc. may become problematic in implementing the desirable width.

When the improvements would be considered technically infeasible or environmentally sensitive, the use of 4 feet minimum sidewalk widths would be acceptable.

Sidewalk Border Design

Where sidewalks are adjacent to swales, ditches or other vertical drop offs, there should be a minimum of two feet of clear space between the edge of the sidewalk and the top of the slope. This clear space should be graded flush with the sidewalk.

Sidewalk Buffer Design

Designers should strive for a desirable quality of service for pedestrians. The width and quality of buffer between the sidewalk and the roadway influence the pedestrian's sense of protection from adjacent roadway traffic. Physical barriers between the sidewalk and roadway such as trees and other landscaping, parked cars, and concrete

barriers and guide rail may increase pedestrian safety and comfort, and therefore encourage higher levels of walking.

The minimum width of a buffer strip is 3 feet (measured from the face of curb to the nearest edge of the sidewalk). The desirable width should be increased up to 6 feet when feasible.

Grades and Cross Slopes

The maximum sidewalk cross slope is 2%. The maximum grade is 12:1 (8.33%), however, the longitudinal grade of the sidewalk should be consistent with the grade of the adjacent roadway. If the 12:1 grade is not feasible due to topography and other physical constraints, then the grade should be developed to the extent feasible. When sidewalk grades steeper than 12:1 for a maximum distance of 30 feet are unavoidable, a level 4 foot long landing should be included if feasible (or at a distance that is practicable).

Surface Treatments

The sidewalk should have a firm, stable slip resistant surface. A concrete surface is preferred; brick or concrete pavers may be used if they are constructed to avoid settling or shifting of bricks. Hot mix asphalt sidewalks may also be used. It is important to avoid ponding on sidewalks.

5.7.4 Public Sidewalk Curb Ramp

General

The ADA Law under 28 CFR Part 35.151(e) provides general direction for the placement of curb ramps:

- Crosswalks can be marked or unmarked but where crosswalks are marked curb ramps should be wholly contained within marked pedestrian crosswalks to enable ramp use to be incorporated as part of the established pedestrian control at the intersection.
- Curb ramps are not limited to intersections and marked crosswalks but should also be considered at other appropriate points of pedestrian concentration or access such as refuge medians/islands, mid-block crossings, parking areas and other traffic separation islands.
- Adequate visibility is required to ensure safe pedestrian movement. A sight distance evaluation is recommended to ensure that curb ramps are not placed at locations where motorists cannot see the low profile of people using mobility devices. For vehicles parking at intersections see Title 39 for parking restrictions. Parking should also be eliminated at midblock crossings to provide access from the curb ramp and to increase the visibility of the pedestrian.

Sidewalks curb ramps and roadway drainage features must be designed and constructed to prevent surface drainage from ponding at the bottom of the curb ramp. Edge of road elevations at the gutter line must be graded to ensure positive drainage. For new construction, additional inlets may be required to prevent drainage issues.

Public sidewalk curb ramps shall be provided where sidewalks permit pedestrian to cross curbs such as at:

- Intersections
- Painted crosswalks at mid-block locations
- Crosswalks at exit or entrance ramps
- Driveways, alleys, passenger loading zones, handicapped parking stalls
- Channelized islands, divisional islands or medians served by crosswalks
- Trail crossings

Existing substandard curb ramps shall be replaced with curb ramps designed in compliance with this section. Designers are to perform field investigation and evaluation of existing curb ramps to determine whether the ramps are substandard.

All new construction, reconstruction, major rehabilitation, widening, resurfacing (open-graded surface course, hot in-place recycling, microsurfacing/thin lift overlay, structural overlays, and mill and fill), cape seals, signal installation, and pedestrian signal installation and major upgrades, and projects of similar scale and effect are subject to the ADAAG contained in this Sidewalks subsection which includes providing curb ramps. In alterations to existing facilities where full compliance with the ADAAG is technically infeasible the alteration shall comply with these standards to the maximum extent feasible. Designers shall document the basis for their determination using Form TIF-1 (ADA Technically Infeasible Form). This form shall be submitted as part of the Final Design Submission (FDS). Form TIF-1 and its instructions are available on the Department's website in the "Engineering" section.

Technically Infeasible means, with respect to an alteration of a building or a facility, something that has little likelihood of being accomplished because existing structural conditions would require removing or altering a load-bearing member that is an essential part of the structural frame; or because other existing physical or site constraints prohibit modification or addition of elements, spaces, or features that are in full and strict compliance with the minimum requirements.

Providing accessibility to the maximum extent feasible applies to the occasional case where the nature of an existing facility makes it virtually impossible to comply fully with applicable accessibility standards through a planned alteration. In these circumstances, the alteration shall provide the maximum physical accessibility feasible. This applies to alterations to an existing facility that cannot fully meet the standards because of existing site conditions. Existing site constraints such as existing utilities, existing structures, environmental/historic impacts or other site constraints may prohibit modification or addition of elements, spaces, or facilities from being in full and strict compliance with the standards. Reasons for providing accessibility to the maximum extent feasible may include the following constraints:

- Existing utilities
- Existing buildings, walls or vaults
- Environmental impacts
- Historic impacts
- Safety
- Roadway profile slope (Terrain)

For less extensive projects, limited improvements to accessibility would generally be expected. For example, if an existing portion of sidewalk along a residential block

were rebuilt or replaced, at a minimum the new portion of sidewalk would be subject to ADA compliance including curb ramps, among other things. However, compliance with these guidelines would not extend to untouched sections of sidewalk outside the planned alterations.

Based on FHWA Office of Civil Rights and the US Department of Transportation General Counsel approval, there are a number of roadway preservation and preventative maintenance projects that do not require curb ramps to be constructed. These projects may involve, but are not limited to:

- Bridge deck patching
- Demolition
- Fencing
- Fender repair
- Fiber optics
- Guide rail
- Landscape
- Raised pavement markers
- Signing and striping in-kind
- Lighting
- Minor Signal Upgrades (i.e. retiming signal installation)
- Utility work that does not alter pedestrian facilities
- Seismic retrofit
- Pavement patching
- Shoulder repair
- Restoration of drainage systems
- Crack sealing
- Bridge painting
- Scour countermeasures
- Other roadway preservation and preventative maintenance projects. The following are some examples of such projects.
 1. Pavement repair
 2. Joint replacement or repair
 3. Bridge deck restoration and component patching
 4. Chip seals
 5. Diamond Grinding
 6. Fog Seals
 7. Joint Crack Seals
 8. Scrub Sealing
 9. Slurry Seals
 10. Spot High-Friction Treatments
 11. Surface Sealing

In most cases, the unique projects mentioned previously will not modify a pedestrian route. However, the designer should consider every project as an opportunity to further the accessibility of its pedestrian network and should not unnecessarily restrict the scope of work so as to avoid the requirements for new curb ramps.

The sight distance should be checked to ensure curb ramps are not placed in such a location that a motorist will find it difficult to perceive the low profile of a mobility device occupant crossing the roadway.

Curb ramps shall be designed to accommodate all users, thus, transitions from the sidewalk to the curb ramp or to the turning space shall be gradual. Relocation of the sidewalk at an intersection is permissible, and in some cases necessary in order to obtain the required sidewalk and curb ramp slope.

Gutters & Counter Slopes

Gutters require a counter slope at the point at which a curb ramp meets the street. This counter slope shall not exceed 5%. The change in angle must be flush, without a lip, raised joint or gap. Lips or gaps between the curb ramp slope and counter slope can arrest forward motion by catching caster wheels or crutch tips.

Turning and Clear Spaces

A curb ramp with a turning space is required wherever a public sidewalk crosses a curb or other change in level. Turning spaces are required anywhere a turning maneuver is required by a user of a mobility device. Turning spaces shall provide a nearly level area (2% cross slope or less) for mobility device users to wait, maneuver into or out of a curb ramp, or to bypass the ramp altogether. A turning space of 4 feet minimum by 4 feet minimum is required. This accommodates the length and wheelbase of mobility devices (standard wheelchairs and scooters). When one curb ramp at the center of the corner radius (corner type curb ramp) is used, the bottom of the curb ramp shall have a clear space 4' minimum outside active traffic lanes of the roadway. The clear space should be wholly within the crosswalks. See Figure 5-Q for illustration.

Landings or a level cut through should also be provided at raised medians or crossing islands.

Running Slope

The curb ramp shall have a running slope of 12:1 maximum. It may be necessary to limit the running slope of a parallel or perpendicular curb ramp in order to avoid chasing grade indefinitely. The curb ramp length should not exceed 15 feet. Adjust the curb ramp slope as needed to provide access to the maximum extent feasible.

Flares

Where a pedestrian circulation path crosses the curb ramp, the ramp is required to have side flares; sharp returns present tripping hazards. This typically occurs where the sidewalk is next to the curb (no grass buffer). Curb ramp flares are graded transitions from a curb ramp to the surrounding sidewalk. Flares are not intended to be mobility device routes, and are typically steeper than the curb ramp (10:1 max) with significant cross-slopes. If curb ramp is situated in such a way that a pedestrian

cannot walk perpendicular across the ramp (ie: blocked by utility pole), flares may be replaced with a 1.5 foot transition or returned curb adjacent to the ramp.

Flares are only needed in locations where the ramp edge abuts pavement. A 1.5 foot transition or returned curb is used where the ramp edge abuts grass or other landscaping. Straight returned curbs are a useful orientation cue to provide direction for visually impaired pedestrians. (See the Construction Details)

Curb Ramp - Types and Placement

The appropriate type of curb ramp to be used is a function of sidewalk and border width, curb height, curb radius and topography of the street corner. There are seven curb ramp types used in street corner designs as shown in the Construction Details. In all cases, the curb ramp should be located entirely within the marked crosswalks (where they exist). Drainage grates or inlets should not be located in the area at the base of the curb ramp. Grates are a problem for mobility devices, strollers and those who use walkers. Wheelchair safe grates should be used where relocation is impracticable.

Two curb ramps are required at each corner, one on each highway within the crosswalk area. If the curb ramp cannot be constructed within the existing crosswalk, the crosswalk shall be modified to include the ramp. The preferred location for a curb ramp is usually parallel to the sidewalk and out of the normal pedestrian path. Where field conditions prohibit the placement of two curb ramps, one ramp at the center of the corner radius is acceptable. Where the travel lane is next to the curb, use a curb ramp at the center of the corner radius in order to provide for a clear space, or a Type 7 curb ramp may be used where needed to ensure that the clear space remains outside the travel way. Curb ramp designs which result in wide painted cross walks greater than 10 feet should be avoided.

The Standard Roadway Construction Detail illustrates the design criteria for public sidewalk curb ramps. The designer should take into consideration the existing conditions at a curb ramp location when evaluating project impacts. These impacts may include constructability issues, quantities and cost.

At a curb ramp location where the sidewalk is greater than 6 feet in width and there is no grass buffer strip, the approach sidewalk transition shall be as shown for Curb Ramp Type 1 and 3 in the Standard Roadway Construction Details. However, where a grass buffer strip exists between the curb and the sidewalk at a curb ramp location, the flared side slope and approach sidewalk transition should be altered as shown for Type 2 and 4 in the Standard Roadway Construction Details.

The designer may want to guide pedestrians away from crossing the mainline of a high volume and/or high speed section of highway except at signalized intersections or at a pedestrian overpass. Therefore, at unsignalized intersections along such highways a curb ramp would be required on the side street corner but not on the mainline corner. In these cases, prohibition for pedestrian crossing signage needs to be provided. Curb Ramp Type 5 and 6 in the Standard Roadway Construction Details are examples of curb ramp locations for crossing the side street. The preferred

treatment for Curb Ramp Type 5 and 6 is out of the normal pedestrian path, but not necessary where right of way width cannot accommodate the offset.

Where there is limited right of way (ROW) at a curb ramp location, the approach sidewalk transition should be altered and the turning space made flush with the gutter line as shown for Curb Ramp Type 7 in the Standard Roadway Construction Details. These limited ROW locations are where the distance from the gutter line to the outside edge of sidewalk is 6 feet or less.

There are also several design solutions that a designer can utilize in order to solve "Limited ROW" constraints without actually acquiring ROW. They are contained in the Special report: Accessible Public Rights-of-Way Planning and Designing for Alterations, Public Rights-of-Way Access Advisory Committee (ACCESS Board), July, 2007, which include but are not limited to:

- Use Curb Ramp Type 3, 4 or 7 where there is not enough room for the landing behind the curb ramp:

This is basically done by employing a Type 3 or 4 type curb ramp. If there still is not enough room, try using a Type 7 curb ramp. If the side street has a high curb, try lowering the curb around the intersection corner radius. For example, if the side street has existing 8 inch curb and it also continues along the corner radius, replace this high curb along the corner radius with 4 inch or less curb and then transition to the 8 inch curb on the side street. This will make your 12:1 ramps much shorter.

- Reduce street width and provide curb ramp type 3, 4 or 7:

Check design vehicle types for turning radius requirements for the particular intersection corner. If a smaller design vehicle can be used at that corner, reduce the corner radius and provide the appropriate curb ramp. By reducing the corner radius, the new gutter line will be moved further into the street creating more room to provide the sidewalk and curb ramps.

- Lower sidewalk to street surface using blended transition:

Lower the sidewalk grade at the intersection to make the sidewalk elevation flush with the gutter elevation. Then provide 12:1 ramps at the radius returns to bring sidewalk up to existing elevation. In other words, make a Curb Ramp type 7 turning space encompass the entire intersection radius.

- Corner Curb extension:

It may be used where posted speeds are 35 MPH or below, see Section 15, "Traffic Calming."

- Elevate intersection to sidewalk level:

A vertical raised intersection may be used where posted speeds are 35 MPH or below, see Section 15, "Traffic Calming."

Intersections may have unique characteristics that can make the proper placement of curb ramps difficult, particularly in alteration projects. However, there are some fundamental guidelines that should be followed.

- Their full width at the gutter line (exclusive of flares) must be within the crosswalk. Aligning the ramp to the crosswalk, if possible, will enable the visually impaired pedestrian to more safely navigate across the intersection and exit the roadway on the adjoining curb ramp.
- Curb ramps should avoid storm drain inlets, which can catch mobility device casters or cane tips.
- Curb ramps should be adequately drained. A puddle of water at the base of a ramp can hide pavement discontinuities. Puddles can also freeze and cause the user to slip and fall.
- Curb ramps must be situated so that they are adequately separated from parking lanes.

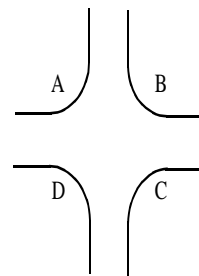
Curb Ramps at Intersections

The clear width of a curb ramp should be a minimum of 4 feet, excluding flares.

The following criteria shall apply to providing curb ramps at intersections:

1. Where all the corners of an intersection have existing or proposed sidewalk, curb ramps shall be provided at each corner.
2. Where all the corners of an intersection do not have existing or proposed sidewalk, the following provisions shall apply:

- a. Where sidewalk exists or is proposed at only one corner, A only, B only, C only or D only; no curb ramp is required. If the curb at the corner with sidewalk is to be constructed or reconstructed, it is optional to provide depressed curb for future curb ramps for compatibility with other corners.



- b. Where there is existing or proposed sidewalk at two adjacent corners only, such as A and B, curb ramps shall be constructed at corners A and B only.
- c. Where there is existing or proposed sidewalk at two diagonally opposite corners only, such as A and C, curb ramps shall be constructed at corners A and C together with a curb ramp at one of the other corners (B or D).
- d. Where sidewalk exists or is proposed at three corners, curb ramps shall be constructed at each corner where existing sidewalk is to remain or where new sidewalk is proposed.

Where a corner at an intersection is without existing or proposed sidewalk, but with curb to be constructed or replaced or with existing curb to remain as is; it is optional to provide depressed curb for future curb ramps.

Where islands exist or are proposed at intersections with curb ramps, the following provisions shall apply:

1. Where a small channelizing island (50 to 75 square feet) is encountered at an intersection, it is not necessary to provide for a curb ramp or walkway opening for the island, but crosswalks shall be adjusted to safely accommodate a person with disabilities without encroaching into the adjacent traveled way.
2. Where a channelizing island is greater than 75 square feet, provide a 5 foot wide walkway opening level with the street in the part of the island intersected by the crosswalk. Where the walkway opening would be long or would create drainage problems, an alternate design is to place curb ramps at both sides of the island where it is intersected by the crosswalks and have a level area of at least 4 feet between the curb ramps.
3. At intersections where a left turn island or divisional island is encountered and the island cannot be moved back so that the nose is out of the crosswalk, provide a 5 foot wide walkway opening level with the street in the part of the island intersected by the crosswalk. See the Standard Roadway Construction Details.

At a location where a curb ramp is not presently required, the curb ramp area should be kept clear of obstructions such as light standards, traffic signals, meter boxes, controller boxes, junction boxes, utility poles, inlets, fire hydrants, guide rail, signs, planters, etc. which would interfere with future curb ramp construction.

The Department's or local public agency's transition plan should be reviewed to determine where future curb ramps are needed. It may be economical to include those improvements with current projects instead of through separate pedestrian improvement projects.

The surface of a public sidewalk curb ramp shall be stable, firm and slip-resistant. The surface of a concrete curb ramp (excluding turning space and flared sides) shall have a detectable warning surface. Detectable warnings shall consist of raised truncated domes and shall be the color red where the adjoining public sidewalk surface is also concrete. Where the adjoining public sidewalk surface is not concrete, the surface of a public sidewalk curb ramp shall contrast visually with adjoining public sidewalk surfaces, either light-on-dark or dark-on-light. Curb ramp surfaces shall be covered with a detectable warning surface per the Standard Construction Details and Specifications. Detectable warning surfaces are also required at pedestrian railroad crossings.

The curb ramp area (curb ramp, turning space, and approach sidewalk transition) shall be kept clear of existing and proposed obstructions such as light standards, traffic signals, meter boxes, controller boxes, utility poles, inlets, fire hydrants, guide rail, signs, planters, etc. Existing obstructions should be relocated as necessary, so as to provide maximum visibility of and for the curb ramp user. The preferred treatment for existing manholes, junction boxes, and valve boxes is to locate them outside of the limits of the curb ramp. However, as an alternate treatment, these items may remain in the curb ramp area and be reset to the slope of the curb ramp. If they are within the area of the detectable warning surface, provide more detectable warning surface

to compensate for the loss of area. Wherever possible, curb ramps should be located to avoid drainage low points in the gutter grade. Gratings or similar access covers shall not be located in the area at the base of the public sidewalk curb ramp.

Accessible Pedestrian Signals, Push Buttons and Curb Ramps

If pedestrian pushbuttons are provided, they should be capable of easy activation and conveniently located near each end of the crosswalk. Curb ramps with a turning space shall allow mobility device users to access existing or proposed pedestrian pushbuttons. Where pedestrian pushbuttons have been provided at intersections with no sidewalk, curb ramps with landing areas shall be provided at both ends of the crosswalk associated with the pedestrian pushbuttons (i.e., Pedestrian pushbuttons may have only been provided to cross the wide state highway and not the narrow side street). See "Section 4E.08 Pedestrian Detectors" of the current Manual on Uniform Traffic Control Devices for guidance on locating pedestrian pushbuttons at curb ramps.

5.8 Driveways

Driveway terminals are, in effect, low volume intersections. The number of driveways and their location has a definite effect on highway capacity, primarily on arterial highways.

Design requirements for driveways and the process under which the Department of Transportation will handle an access permit request are contained in the Department's publication, New Jersey State Highway Access Management Code and the Access Design Guidelines, 2012.

To determine the adequacy of the sight distance at driveways, see Section 6 for sight distance at intersections.

Sidewalks across driveways shall have a 2% maximum cross slope where placing new sidewalk at driveways or reconstructing driveway aprons.

5.8.1 Pedestrian Accommodations at Driveways

In commercial areas, conventional driveways (i.e. where there is a change in grade between the street and abutting property and the driveway entrance is connected to the street via a sloped concrete apron) are preferred over access points that resemble at-grade street intersections where there is no grade change. In the design of conventional driveways, the pedestrian right of way is established more clearly and vehicles must turn more slowly into and out of the driveway. If an intersection-style driveway is used, vehicle turns can be slowed by using a small curb radius. In addition, driveway width should be made no wider than necessary. Wide driveways allow faster turns and more exposure for pedestrians. The sidewalk at driveways should remain at grade and may have the same surface material or crosswalk delineation across the driveway so motorists know they are crossing a pedestrian access route.

The intersection of driveways and sidewalks are the most common locations for severe cross slopes for sidewalk users. Sloped driveway entrances can cause mobility device users to lose directional control, veer downhill toward the street and potentially tip over. Therefore, the following solutions are recommended:

- At locations with a buffer between the sidewalk and the street, provide a level path of pedestrian travel (as an extension of the regular sidewalk) through the driveway cut, and resume the driveway slope within the buffer.
- On narrow sidewalks against the curb, achieve a similar level landing area by moving the sidewalk back away from the highway as it crosses the driveway, where possible.
- Lower the driveway crossing to the grade of the street similar to a curb ramp type 7 as per the Standard Roadway Construction Details. (Note, although this solution is preferable to a severe cross slope, it can create steep grades on both sides of the driveway and can cause drainage problems on the landing.)

Sidewalk crossings of residential driveways and most commercial driveways should not generally be provided with detectable warning surfaces, since the pedestrian right-of-way continues across most driveway aprons and the overuse of detectable warning surfaces diminishes message clarity. However, where commercial driveways are provided with traffic control devices or otherwise are permitted to operate like public streets, detectable warnings should be provided at the junction between the pedestrian route and the street.

5.9 Medians

5.9.1 General

A median is a highly desirable element on all arterials carrying four or more lanes. It separates the traveled ways for traffic in opposing directions. The median width is expressed as the dimension between the through lane edges and includes the left shoulders, if any. The principal functions of a median are to:

1. Provide the desired freedom from the interference of opposing traffic.
2. Provide a refuge area for pedestrians and bicyclists.
3. Provide a recovery area for out of control vehicles.
4. Provide a stopping area in case of emergencies.
5. Provide for speed changes and storage of left turning and U turning vehicles.
6. Minimize headlight glare.
7. Provide width for future lanes.
8. Add open green space in an urban area.
9. Serve as traffic calming devices on low speed roadways.

For maximum efficiency, a median should be highly visible both night and day and in definite contrast to the through traffic lanes. A median may vary in scope from pavement markings to an expansive grass area of varying width between two independently designed roadways. Medians may be depressed, raised, or flush with the pavement surface.

5.9.2 Islands, Medians, and Pedestrian Refuges

Along with their function of controlling and directing traffic movement (usually turns), and dividing traffic streams, islands serve to increase the safety and comfort of pedestrians crossing at intersections and midblock locations by providing a refuge. When channelizing islands are designed for this purpose, they are often termed "pedestrian crossing islands" or "median refuges." See Sections 5.7 and 6.5 for design guidance.

The effective width of a median used as a pedestrian refuge and for traffic calming purposes is the width of the raised portion. In order for a median to function as a refuge, the raised portion of the median must be at least 6 feet wide. Medians should be as wide as feasible, but of a dimension in balance with other components of the cross section. The general range of median widths is from a minimum of 6 feet, to a desirable dimension of 84 feet or more on freeways and rural areas. When not utilized as a refuge or for traffic calming, medians can be as narrow as 4 feet, in which case the detectable warning surface (DWS) should be omitted.

Desirable median width without a barrier for urban land service highways should be 32 feet to accommodate future widening (a future 12 foot lane, 3 foot shoulder in each direction with a 2 foot median concrete barrier curb) and 16 feet where no future widening is anticipated. Desirable and minimum median widths without a barrier for rural land service highways should be 46 feet (to accommodate future 12 foot lane and 5 foot wide shoulder in each direction with a 12 foot grass median) and 36 feet (to accommodate a future 12 foot lane and 5 foot shoulder in each direction with a 2 foot median concrete barrier curb), respectively grass median may have sloping curb on both sides. For minimum median widths with barrier and for median widths for freeways, see the typical sections illustrated at the end of this section.

Medians 5 feet or less in width will be paved, except where the special nature of an area might warrant the higher cost and risk involved in maintaining grass. Special areas might be parks or refined areas in towns or cities where a narrow grass strip would be in harmony with the surroundings or where shrubbery is planted to reduce oncoming headlight glare.

Where practical, nose areas shall be paved back to a point where the distance is 5 feet between curblines.

In general, the median should be as wide as can be used advantageously. As far as the safety and convenience of motor vehicle operation are concerned, the farther the pavements are apart, the better. However, economic factors limit the width of median that can be provided. Construction and maintenance costs increase generally with an increase in the width of roadbed, but the additional cost may not be appreciable compared with the cost of the highway as a whole and may be justified in view of the benefits derived. A distinct advantage of wider medians on roadways, other than freeways, is to provide adequate shelter for vehicles crossing at intersections with public roads and at crossovers serving commercial and private drives. However, wide medians are a disadvantage when the intersection is signalized. The increased time for vehicles to cross the median may lead to inefficient signal operation.

If the right of way is restricted, the median should not be widened beyond a desirable minimum at the expense of narrowed roadside areas. A reasonable roadside width is required to adequately serve as a buffer between the private development along the road and the traveled way, particularly where zoning is limited or nonexistent. Space must be provided in the roadside areas for sidewalks, highway signs, utility lines, drainage channels and structures, and for proper slopes and any retained native growth. Narrowing these areas may tend to develop hazards and hindrances similar to those that the median is designed to avoid.

Raised medians have application on arterial streets where it is desirable to regulate left turn movements. They are also frequently used where the median is to be planted, particularly where the width is relatively narrow. It must be pointed out, however, that planting in narrow medians creates hazardous conditions for maintenance operations.

Flush medians are used to some extent on all types of urban arterials. When used on freeways, a median barrier may be required. The median should be slightly crowned or depressed for drainage.

Additional discussion on median openings and intersections including emergency median openings on land service highways and freeways is discussed in Section 6, "At-Grade Intersections."

5.9.3 Median Fencing on Land Service Highways

This section pertains to the installation of fence on top of median barrier curb or in grass medians along our State land service highways. The purpose of the fence is to prohibit the unlawful and potentially dangerous crossing of the highway by pedestrians where barrier curb or a grass median exists. It is the Department's policy to provide median fencing on a case by case basis only.

Fencing in the median may be considered when there is a known pedestrian/vehicle crash history, or the Department has been requested by the local municipality to eliminate an illegal pedestrian crossing of the median. Upon notification of such a problem or when requested by the local municipality; the local municipality (township engineer, police, etc.) should be contacted for their input, accident reports should be requested and analyzed and a field review of the site should be conducted in order to determine the exact location and reason for the illegal pedestrian crossings. An example of a reason for an illegal pedestrian crossing may be that pedestrians at a bus stop are crossing the highway to get to and from their vehicles parked on the opposite side of the highway.

If the pedestrian crossing is an isolated incident, fencing or other countermeasures are not warranted. If the pedestrian crossing is an ongoing patterned problem, evaluate the following safety countermeasures for use before installing fence in the median. They can be used by themselves or in combination with each other:

- Relocate the midblock bus stop and/or crossing closer to the signalized intersection.
- Provide mid-block crossing location(s) as per Section 14-12.1
- Coordinate the adjacent pedestrian network with safe crossing locations. For example, a pathway may be re-oriented so that it leads directly to an intersection, overpass or midblock crosswalk. The site may be graded to naturally direct pedestrians.
- Contact the local police department and request that they step up policing of jaywalkers.
- Encourage safe use of crosswalks at signalized intersections by providing clearly defined crosswalks, pedestrian actuated signals and signs. Provide proper traffic signal signs for the instruction of pedestrians and drivers, see "Section 2B 37" of the current Manual on Uniform Traffic Control Devices for Streets and

Highways (MUTCD). Provide pedestrian crossing signs to selectively aid in limiting pedestrian crossing to safe places. For proper placement of these signs, see "Section 2B 36" of the MUTCD.

- Provide a pedestrian overpass if intersection/ interchange spacing exceeds one mile and if a user benefit cost analysis warrants an overpass. A pedestrian overpass is very effective when accompanied by median fencing.
- Provide roadway lighting.

Only after the previous countermeasures are evaluated and implemented should the engineer consider providing fencing in medians. That is, fencing should be used as a last resort. Fencing in medians should stop approximately 90 percent of the pedestrian crossings; however, it has its drawbacks. If the decision is made to install median fencing, the following issues should be recognized:

- Difficulty in maintaining fence on median barrier curb.
- Potential to reduce horizontal sight distance when installed on median barrier curb.
- Litter can be a problem along fence located in grass medians adjacent to high litter generators such as shopping malls.

Median fencing should be installed in well-lighted areas so that pedestrians can see the fence prior to attempting to cross the highway at night. Where existing roadway lighting is inadequate, provide additional roadway lighting in accordance with Section 11, "Roadway Lighting Systems."

Adequate sight distance at intersections and emergency U turns should be provided when designing limits of fencing. Therefore, fencing on barrier curb shall stop a minimum of 300 feet from the median barrier curb terminal, and fencing in grass medians shall terminate a minimum of 200 feet from the end of the grassed island. Fencing shall not be installed in medians where there is substandard horizontal stopping sight distance.

When installed on median barrier curb, chain link fabric shall be 4 feet high, with 3 inches diamond mesh.

When installed in grass medians, the chain link fabric shall be 6 feet high, with 3 inches diamond mesh. All chain link fence posts within the clear zone shall be made breakaway (i.e., breakaway coupling).

5.10 Standard Typical Sections

Typical sections should be developed to provide safe and aesthetically pleasing highway sections within reasonable economic limitations.

The typical sections shown in the plans should represent conditions that are "typical" or representative of the project. It is not necessary to show a separate typical section to delineate relatively minor variations from the basic typical. The most common or predominant typical section on the project should be shown first in the plan sheets followed by sections of lesser significance.

Figures 5 B through 5 J inclusive illustrate the various control dimensions for single lane and multi-lane highways.

5.11 Bridges and Structures

5.11.1 General

Designers should make every effort during the early design phase to eliminate or minimize certain features on bridge decks such as, horizontal curves, vertical curves, variable horizontal widths and cross slopes. Locating these features off the structure simplifies construction, is more economical and reduces future maintenance requirements.

For further information, the designer should review Section 5.2., "Geometrics on Bridges" in the Design Manual Bridges and Structures.

5.11.2 Lateral Clearances

It is desirable that the clear width on the bridge be as wide as the approach pavement plus shoulders.

On underpasses, the desirable treatment is to maintain the entire roadway section including median, pavements, shoulders and clear roadside areas through the structure without change.

Minimum lateral clearances are illustrated in Figures 5 K through 5 P inclusive.

On divided highways where the median width is less than 30 feet consideration should be given to eliminating the parapets and decking the area between the structures.

5.11.3 Vertical Clearance

Vertical clearances for bridges and structures shall be in accordance with Section 3.2, Vehicular Bridge Structures, of the Design Manual Bridges and Structures.

Bridges and Structures Design should be notified of all changes in bridge clearances.

5.12 Rumble Strips

5.12.1 General

One method of making roadways safer is by constructing longitudinal rumble strips. The audible warning and vibration made when vehicle tires pass over rumble strips alert motorists that their vehicles have drifted out of their intended travel lane adjacent to a shoulder or the centerline, and that the driver needs to take corrective action to possibly avoid an accident. Rumble strips are constructed on the shoulders of divided highways and freeways; and on undivided roadways, rumble strips are constructed on the centerline and/or the outside shoulder of the pavement.

Rumble strips shall not be constructed on bridge decks or on bridge approaches, but may be constructed on HMA overlays over bridge approaches. Do not construct rumble strips on concrete pavement.

See the Standard Roadway Construction Details for rumble strip layouts and dimensions.

5.12.2 Shoulder Rumble Strips

Along the mainline on all Interstate highways, freeways, and other limited access highways, shoulder rumble strips shall be constructed on inside shoulders that are 3 feet or greater in width and outside shoulders that are 6 feet or greater in width.

Along the mainline of land service highways, shoulder rumble strips shall be constructed on inside shoulders that are 3 feet or greater in width and outside shoulders that are 6 feet or greater in width at locations where:

- Crash data indicates an overrepresentation of roadway departure crashes as compared to the statewide average for the most recent 3 year period.
- The shoulder approaching a bridge overpass or underpass is reduced or eliminated. (In this instance, the rumble strips shall be provided a minimum of 500 feet in advance of the bridge.)

The use of shoulder rumble strips may still prove to be beneficial along the mainline of land service highways where these warrants are not met. For example, when roadside or median obstructions exist that cannot be eliminated or mitigated (refer to Section 8). These cases must be evaluated on an individual basis, and engineering judgment shall be employed in the solution.

Shoulder rumble strips shall not be constructed 100 feet in advance of and beyond all street intersections and commercial driveways. The minimum length of rumble strips measured longitudinally along the shoulder shall be 100 feet.

In order to maintain the integrity of the hot mix asphalt (HMA) pavements, the pavement box under the rumble strips must have a minimum thickness of four inches of hot mix asphalt material.

5.12.3 Centerline Rumble Strips

Centerline rumble strips shall be constructed at the yellow centerline stripe location in rural and urban areas on two-lane roads and multilane undivided highways. Roadway characteristics that warrant centerline rumble strips are:

- Roads with posted speed limits of 35 mph or higher
- Minimum lane width of 10 feet
- HMA pavement must be in good condition with a surface distress index (SDI) greater than 3. Consult with the Pavement Management Unit.

Centerline rumble strips should be specified regardless of the presence of passing zones.

Centerline rumble strips shall be constructed to the end of the centerline stripe at all street intersections.

Centerline rumble strips shall not be constructed along left turn slots and continuous two-way left-turn median lanes.

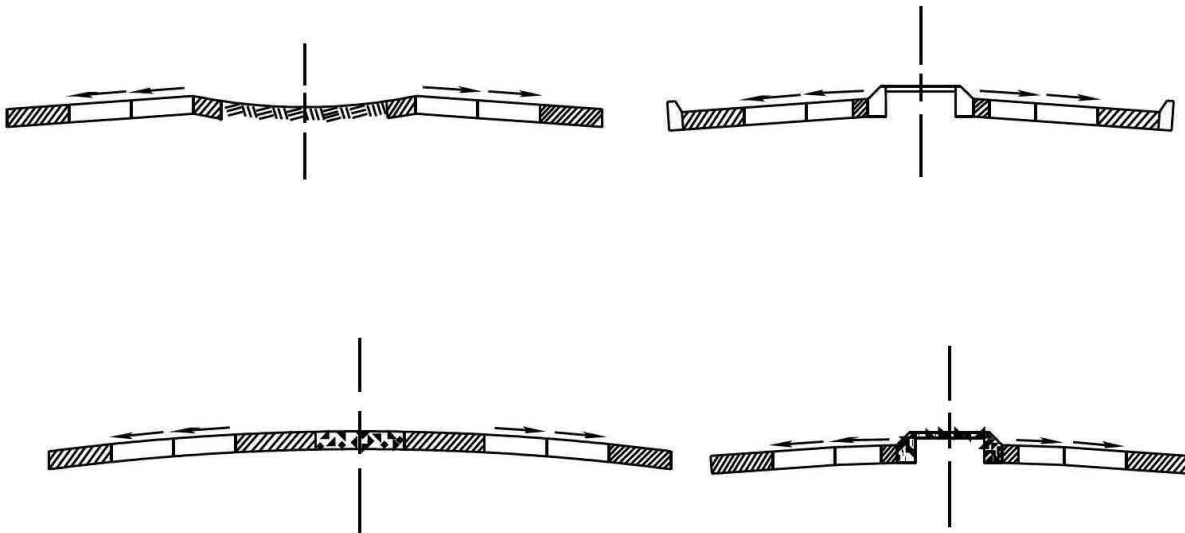
The minimum length of rumble strips measured longitudinally along the centerline shall be 100 feet.

Fog seal surface treatment shall be applied after construction of the centerline rumble strips. Wait for fog seal treatment to cure based on manufacturers recommendation before application of permanent traffic stripes.

FIGURE 5-A: PAVEMENT CROSS SLOPES



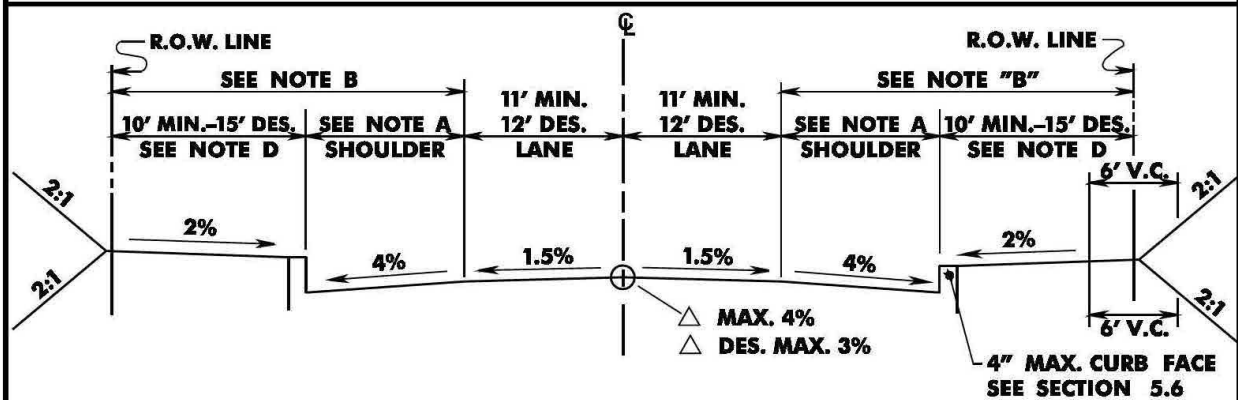
EACH PAVEMENT SLOPES TWO WAYS



EACH PAVEMENT SLOPES ONE WAY

REV. DATE: JUNE 30, 2015

FIGURE 5-B: LAND SERVICE HIGHWAYS



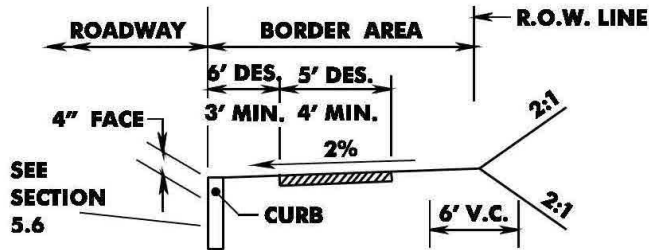
TWO-LANE ROADWAY

NOTES:

- A. Shoulder width shall be 8 feet absolute minimum or 10 feet minimum desirable. Shoulder width may be increased to 12 feet maximum when a large volume of trucks is anticipated (250 DHV), when turning volumes are high or dualization is anticipated.
- B. Desirably the clear zone distance plus 5 feet from the edge of thru lane to the Right of Way Line for the corresponding design speeds should be provided - 60 MPH, 35 feet; 55 MPH, 30 feet; 50 MPH or less, 25 feet.
- C. Curb section may be used with or without sidewalk. Curb section shall be used for access control, where pedestrian traffic is anticipated or where necessary for drainage.
- D. The border width on existing highway may be reduced to 8 feet to accommodate the widening of lanes and/or shoulders.
- E. All utility poles shall be located as close to the R.O.W. line as possible.
- F. Bicycle lanes may be incorporated into a roadway section when it is desirable to delineate available road space for preferential use by bicyclists. Generally, they are placed on the right side of the roadway and maybe separate from or within the shoulder area.
- G. Parking space maybe incorporated into a roadway section. Generally the space allocated for the shoulder within a roadway section would be designated as a parking area. Typically parking areas would be located on urban roadways or areas designated for traffic calming.

REV. DATE: JUNE 30, 2016

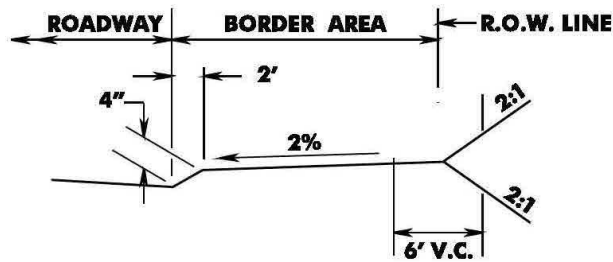
FIGURE 5-B1: LAND SERVICE HIGHWAYS BORDER AREAS



CURB SECTION

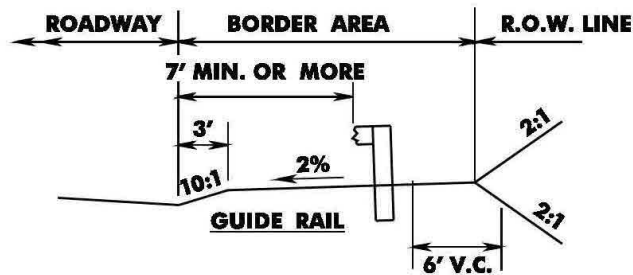
With Provision For Sidewalk

SEE NOTE C ON FIGURE 5-B



BERM SECTION

With Provision For For Future Sidewalk

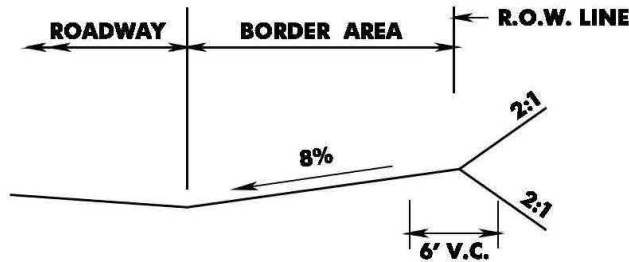


BERM SECTION

With Provision For For Future Sidewalk With Guide Rail

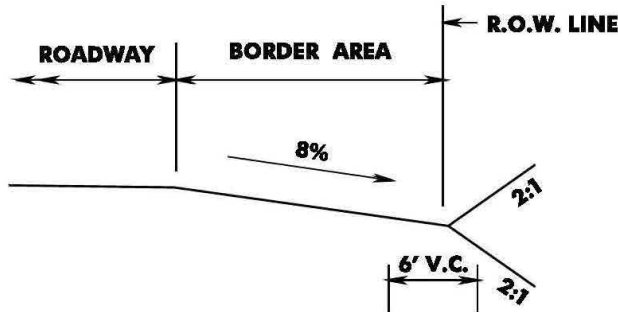
FOR ALL SECTIONS SEE NOTE "E" ON FIGURE 5-B

FIGURE 5-B2: LAND SERVICE HIGHWAYS BORDER AREAS



NON-BERM SECTION

With No Provision
For Sidewalk



UMBRELLA SECTION

With No Provision For
Sidewalk

SEE NOTE A

NOTES:

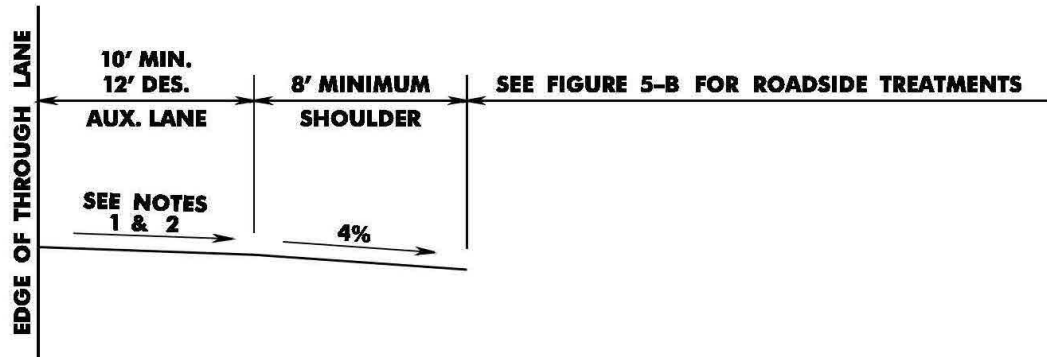
- A. UMBRELLA SECTION MAY BE USED WHERE THERE IS NO PROVISION FOR SIDEWALK; AND CURBS ARE NOT REQUIRED FOR DRAINAGE AND ACCESS CONTROL (SUCH AS RURAL RESIDENTIAL DRIVEWAYS).

THIS SECTION MAY BE SUITABLE FOR SANDY AREAS, WETLAND AREAS,
AND ALONGSIDE EXISTING OR PROPOSED DITCHES OR SWAILS.

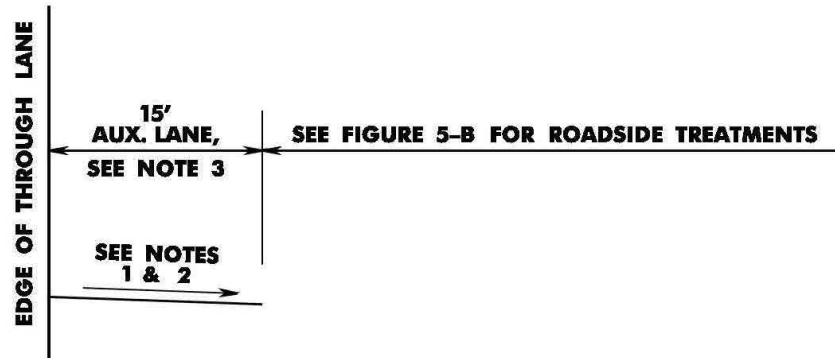
FOR ALL SECTIONS SEE NOTE "E" ON FIGURE 5-B

REV. DATE: JUNE 30, 2015

FIGURE 5-C: LAND SERVICE HIGHWAYS



PREFERRED AUXILIARY LANE AT INTERSECTION – TREATMENT



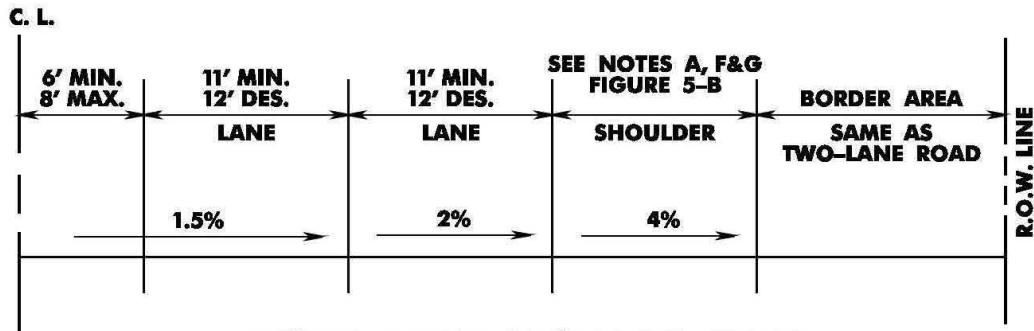
ALTERNATE AUXILIARY LANE AT INTERSECTION – TREATMENT

NOTES:

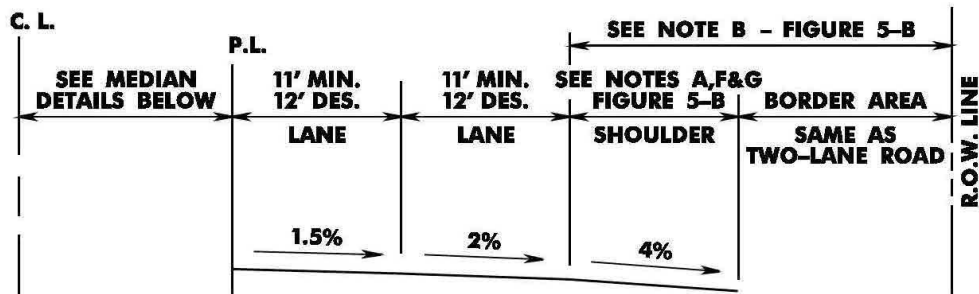
1. For Normal Crown Sections, cross slope should be 1/2% greater than adjacent through lane. Maximum cross slope desirably should not exceed 2.5%.
2. For Superelevated Section, the cross slope should be the same as the adjacent through lane. See Section 7.6.2 on the development of superelevation at Free-Flow Ramp Terminals.
3. Where alternate bike route is provided, alternate Auxiliary Lane width may be one foot wider than adjacent lane.

REV. DATE: JUNE 30, 2015

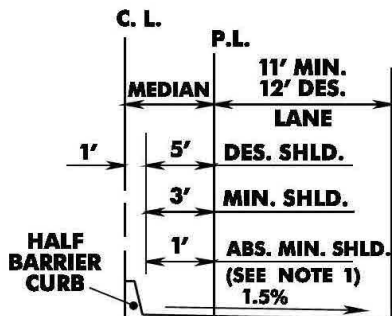
FIGURE 5-D: LAND SERVICE HIGHWAYS



**FOUR LANE HIGHWAY WITH
TWO-WAY LEFT TURN LANE HALF SECTION**

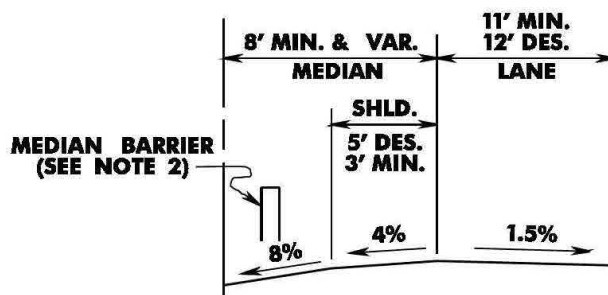


FOUR LANE - DIVIDED HIGHWAY HALF SECTION



MEDIAN HALF SECTION

NO DRAINAGE IN MEDIAN



MEDIAN HALF SECTION

DRAINAGE IN MEDIAN

NOTES:

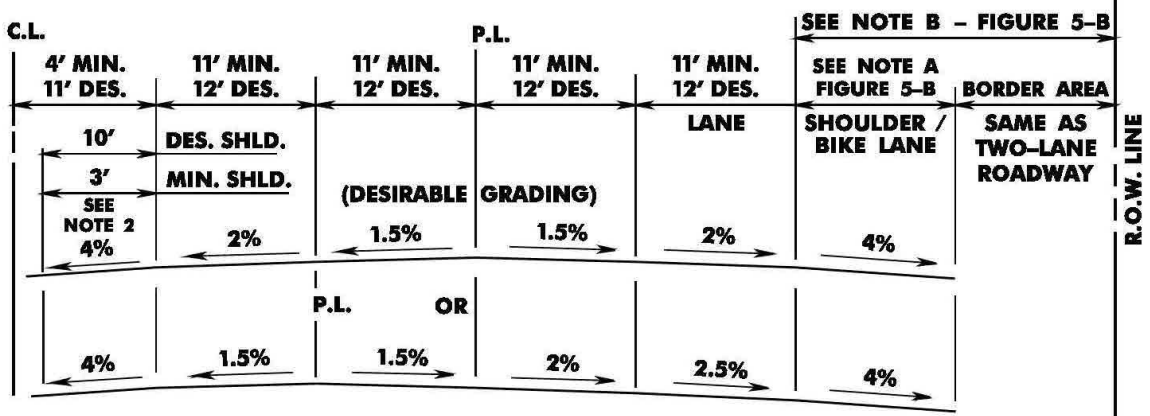
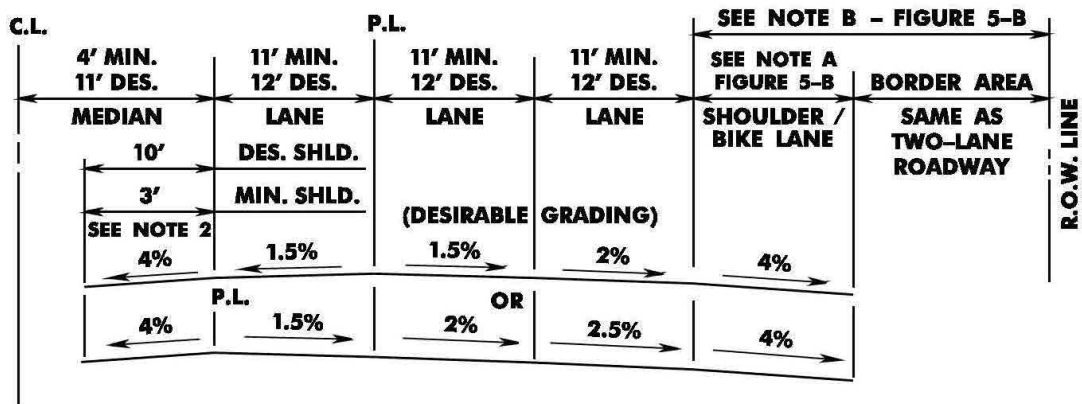
1. Applicable to existing highways only.
2. Median Barrier may be located at or on either side of Low Point.

REV. DATE: JUNE 30, 2015

FIGURE 5-E: LAND SERVICE HIGHWAYS

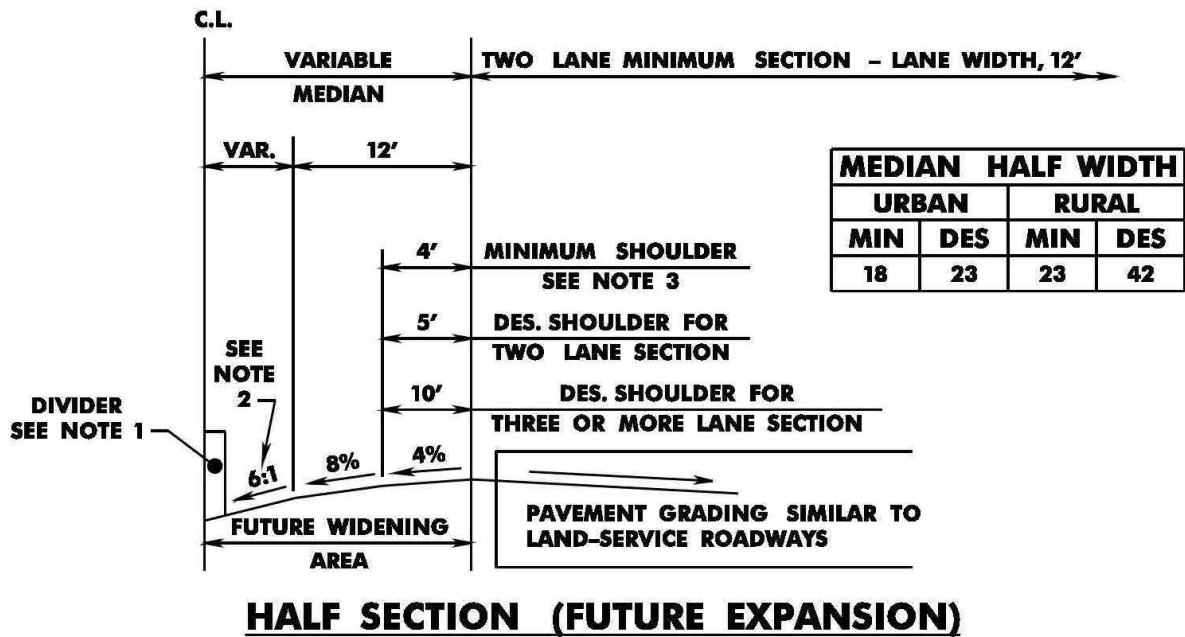
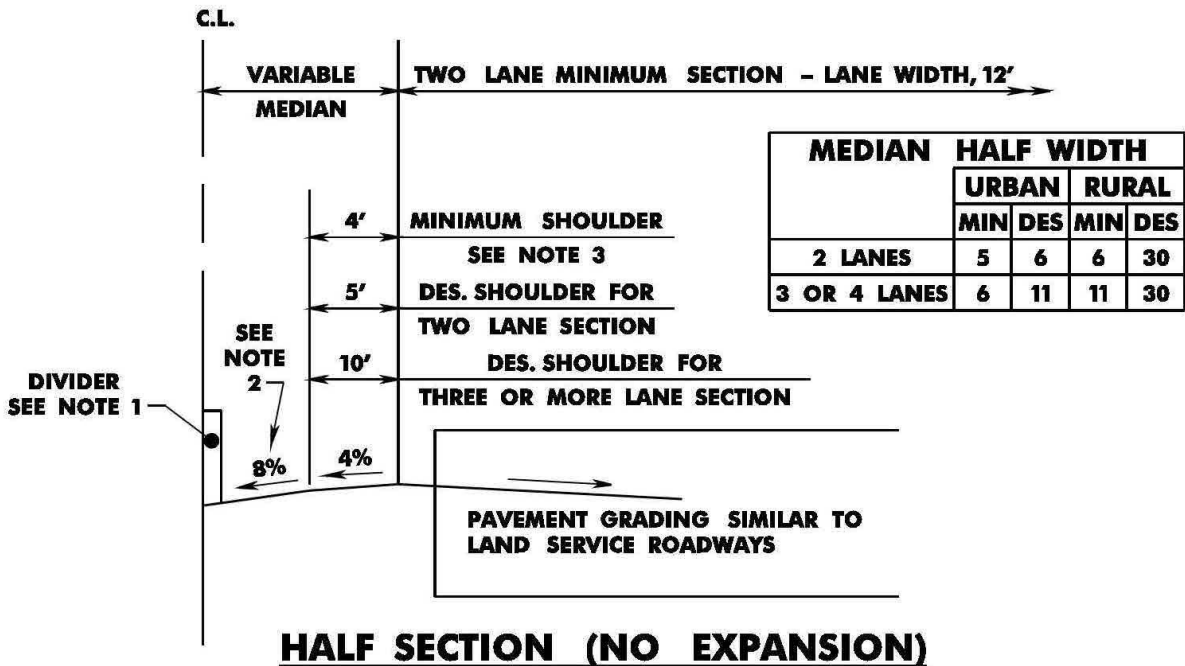
NOTES:

1. Median Barrier will be selected as per Section 8, Guidelines for Guide Rail and Median Barriers.
2. Where left shoulder width is less than 5 feet and median slopes away from roadway, the shoulder cross slope may be at the same rate and direction as the adjacent lane.



REV. DATE: JUNE 30, 2015

FIGURE 5-F: FREEWAY SECTIONS

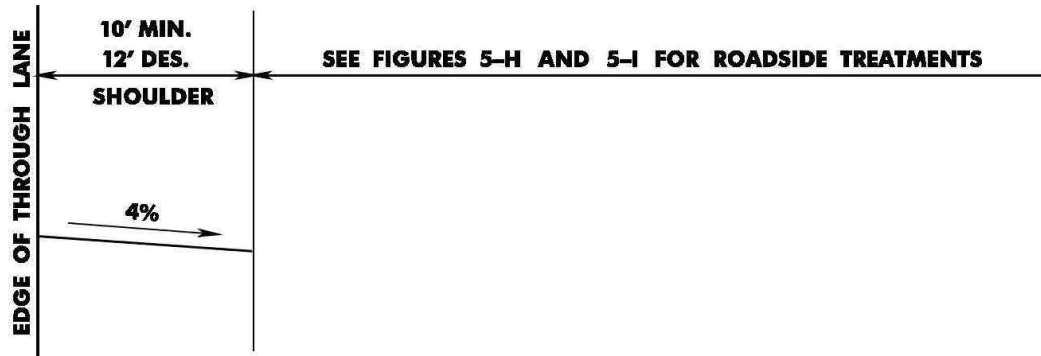


NOTES:

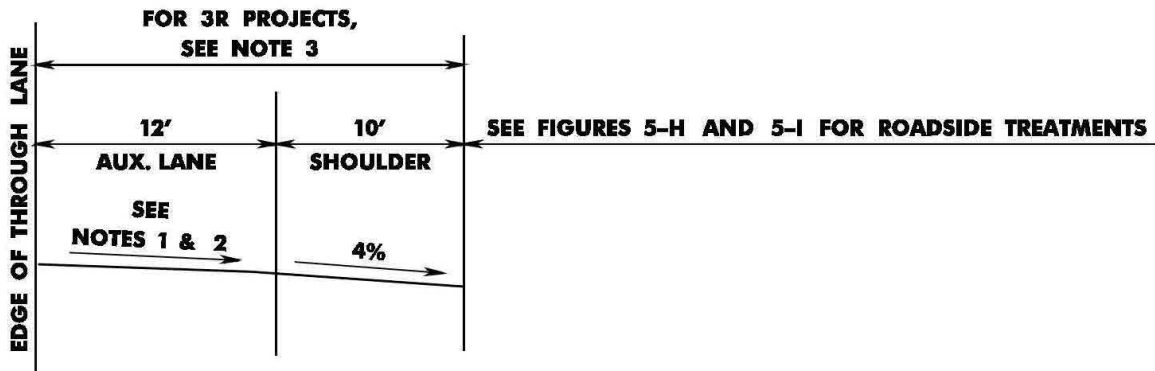
1. For Median Barrier Warrants see Section 8.6.1.
2. Maximum sideslope adjacent to a Median Barrier is 10:1.
3. See Figure 5-E, Note 2.

REV. DATE: JUNE 30, 2015

FIGURE 5-G: FREEWAY SECTIONS



SHOULDER TREATMENT



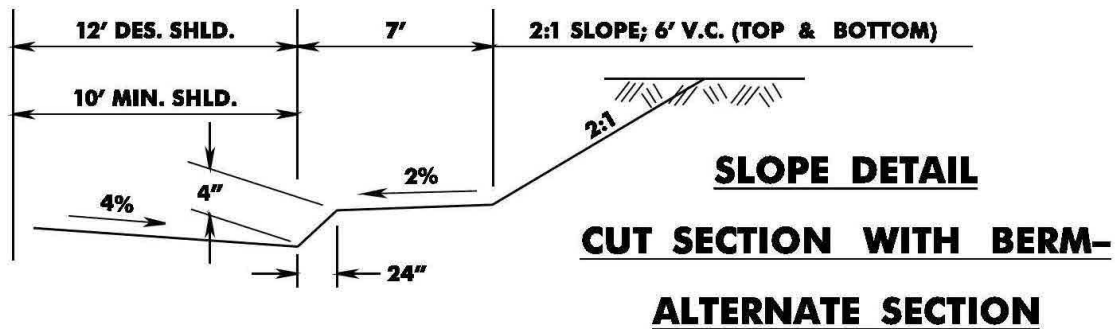
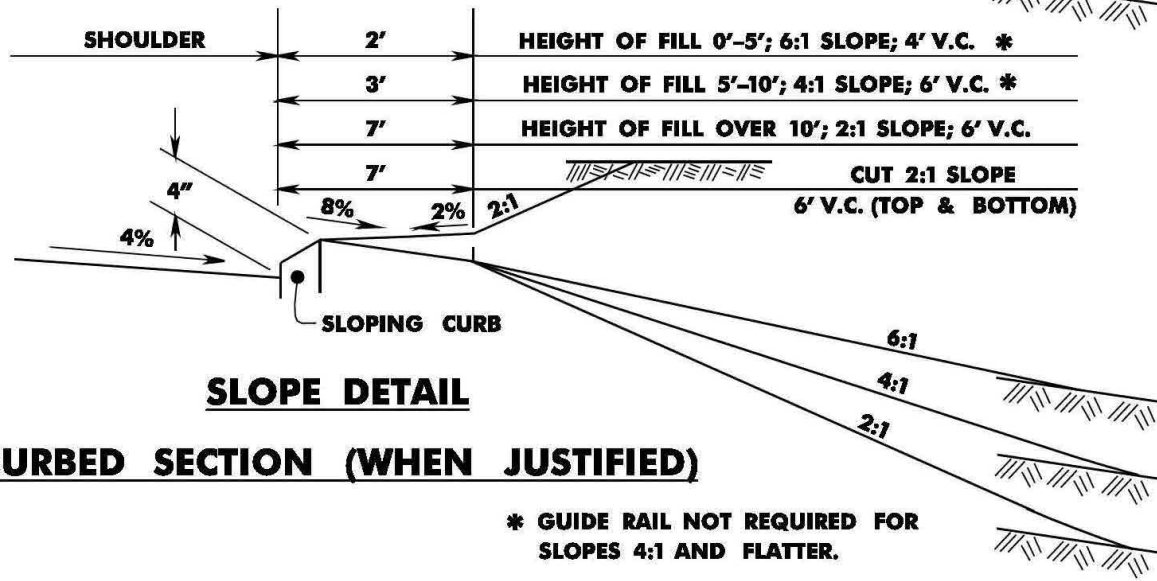
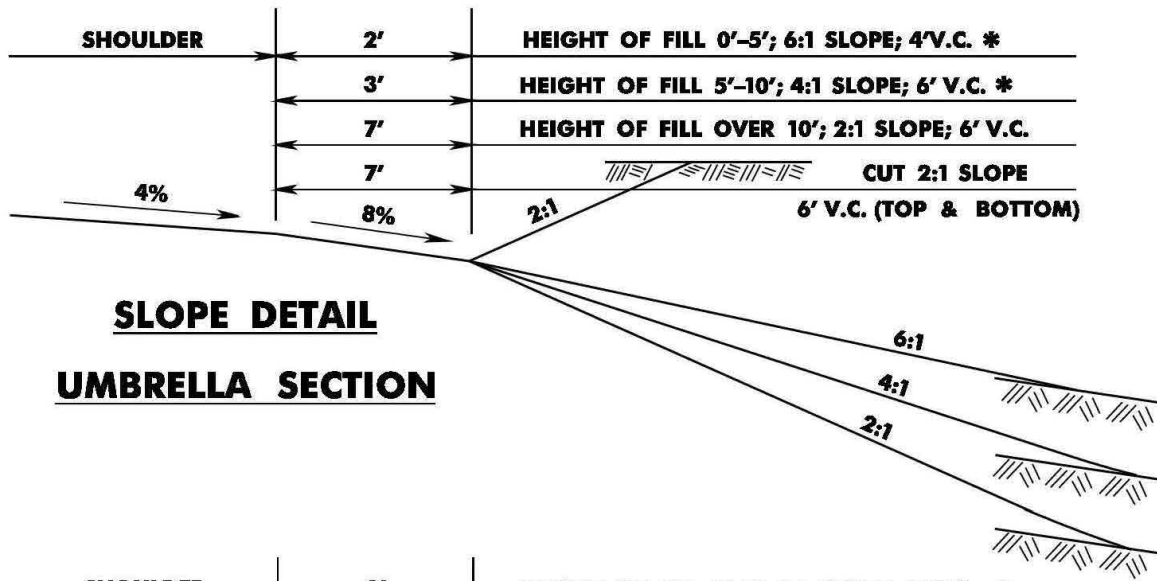
AUXILIARY LANE TREATMENT

NOTES:

1. For Normal Crown Sections, cross slope should be 1/2% greater than adjacent through lane. Maximum cross slope desirably should not exceed 2.5%.
2. For Superelevated Sections, the cross slope should be the same as the adjacent through lane. See Section 7.6.2 on the development of superelevation at Free-Flow Ramp Terminals.
3. Where no shoulder exists, the existing Auxiliary Lane width may be maintained on 3R projects. However, whenever practical, a 10 foot desirable or a 6 foot minimum shoulder should be provided on 3R projects.

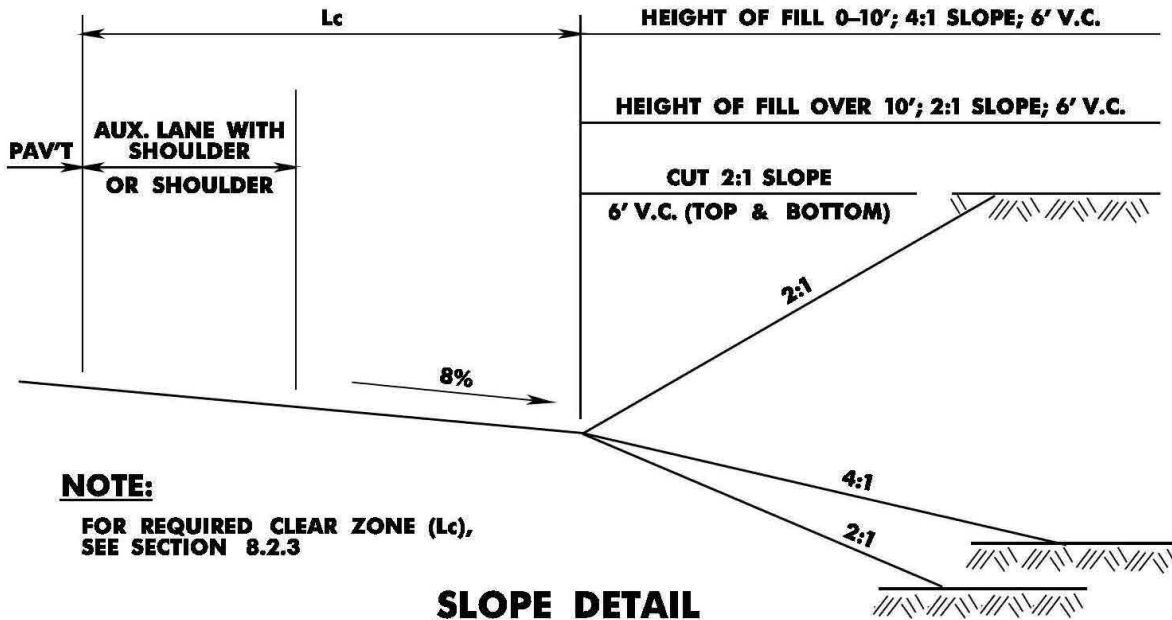
REV. DATE: JUNE 30, 2016

FIGURE 5-H: FREEWAY SECTIONS



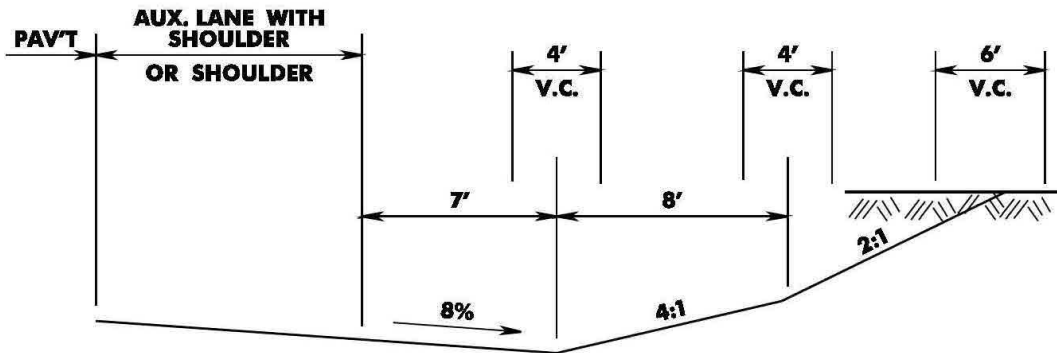
REV. DATE: JUNE 30, 2015

FIGURE 5-1: FREEWAY SECTIONS



SLOPE DETAIL

UMBRELLA SAFETY SECTION

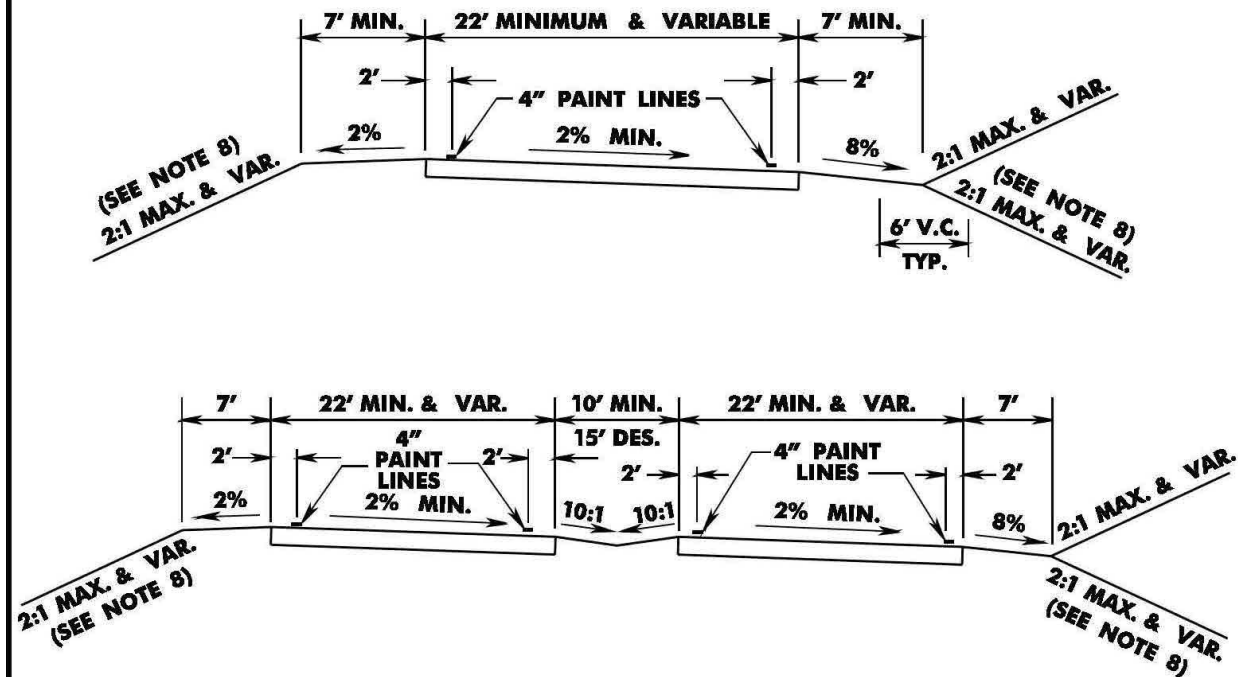


SLOPE DETAIL

ALTERNATE - CUT SAFETY SECTION

REV. DATE: JUNE 30, 2015

FIGURE 5-J: RAMP SECTIONS

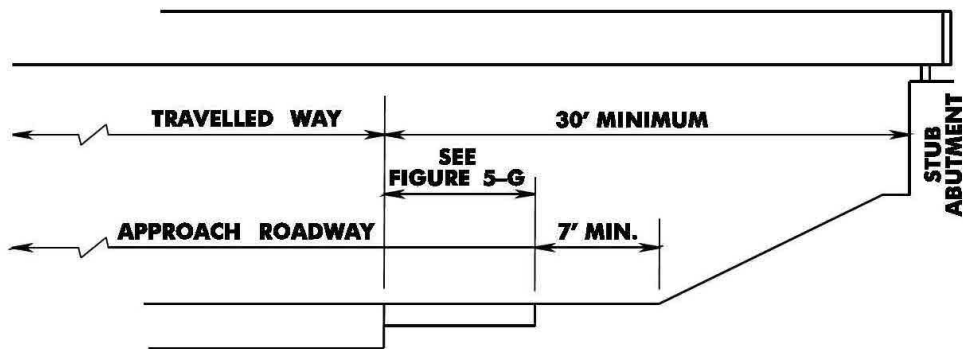
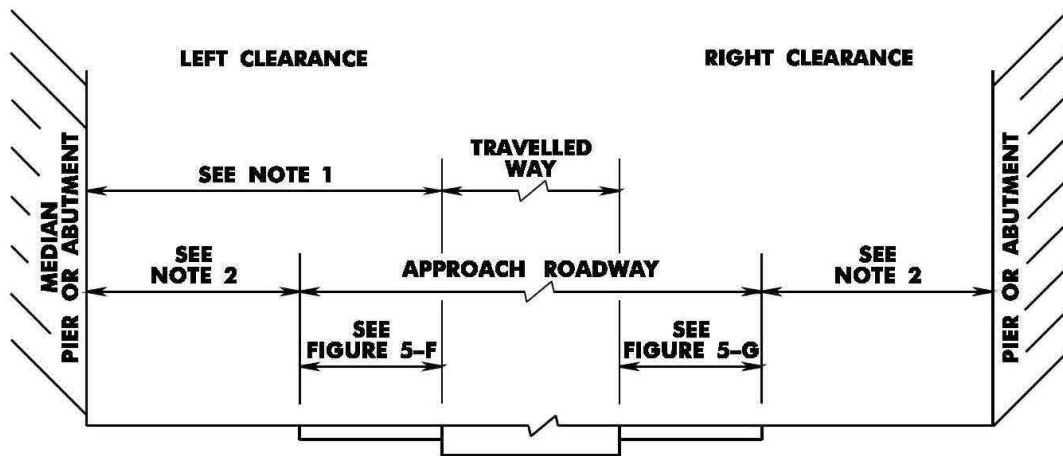


NOTES:

1. The minimum ramp width is 22 feet, the width should be adjusted based on various operating conditions, design vehicle and curvature. The required width should be based on the smallest radius of the ramp proper and is applicable throughout the full length of the ramp (See Figure 7-B).
2. Superelevation should be provided on ramps.
3. Side slopes where practical should be flattened to eliminate the need for guide rail.
4. Curb may be provided on ramps when required for drainage control or access control. Maximum curb height is 4 inches.
5. The median width on opposing ramps may be reduced to 4 feet where curb is provided and ramp speeds are 25 MPH or less.
6. Where barrier curb is provided to separate opposing directions of travel, the median width should be 8 feet.
7. Guide rail should be located according to the "Guidelines for Guide Rail Design and Median Barriers", Section 8.
8. Interior side fill slopes on ramps should be 4:1.
9. 2' paint line offset provided for inlet placement and to minimize covering of line with debris (dirt, grass clippings, etc.).

REV. DATE: JUNE 30, 2015

FIGURE 5-K: LATERAL BRIDGE CLEARANCES



INTERSTATE OR FREEWAY UNDERPASS

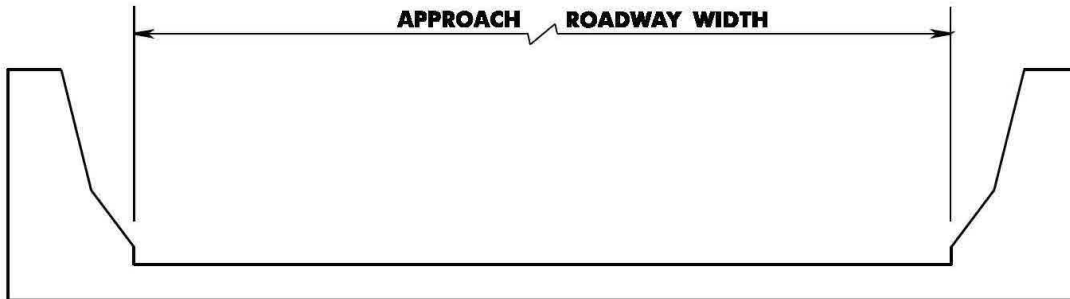
NOTES:

1. When practical, place pier at centerline of median. Provision for additional lanes should be considered when determining pier or abutment location. If there is a continuous median barrier the offset should be sufficient to construct the barrier in front of the pier without reducing the shoulder width.
2. Where guide rail is used for shielding and vertical curb is not present, the minimum offset from the edge of roadway to pier or abutment is 8'-3" (4' from back of rail element to pier) and 4'-9" (guide rail attached to abutment), respectively. Where barrier curb is used, use a 3'-3" offset from the gutter line to the face of median obstruction, since high profile vehicles have a tendency to lean when hitting barrier curb and may strike the obstruction behind it.

Note: These dimensions are minimums. Designs which eliminate the need for longitudinal barrier are preferred when practical.

REV. DATE: JUNE 30, 2015

FIGURE 5-L: LATERAL BRIDGE CLEARANCES



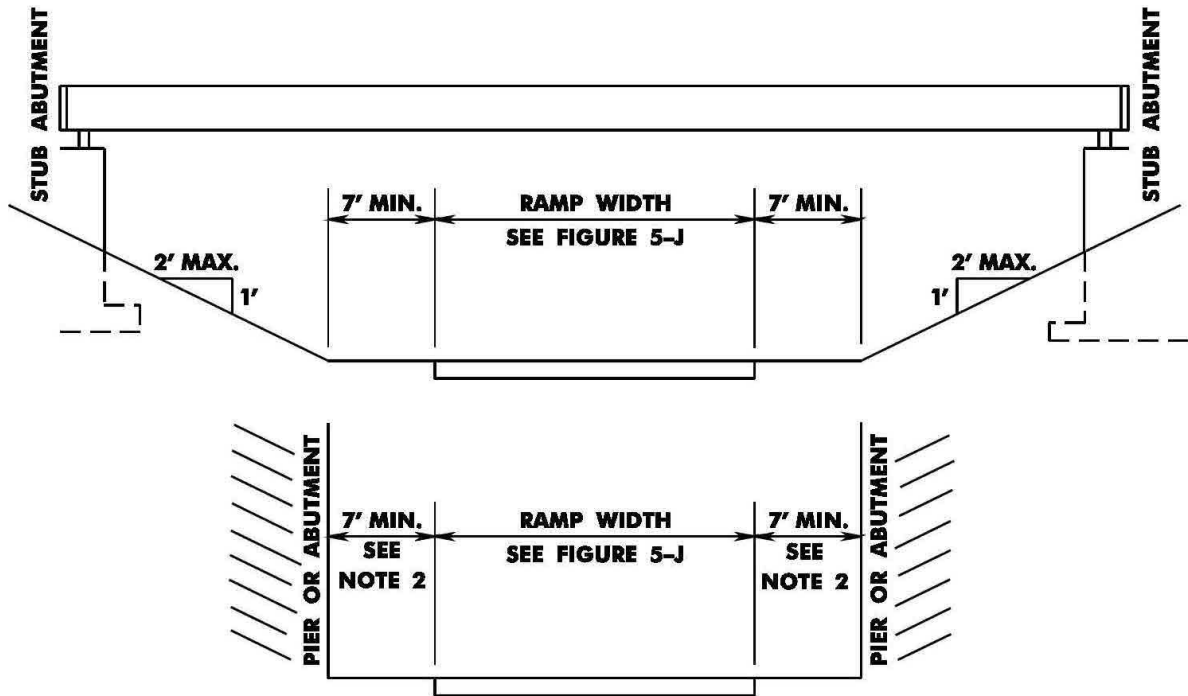
INTERSTATE OR FREEWAY OVERPASS

NOTE:

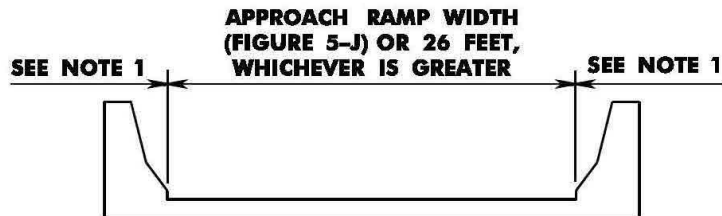
1. Stopping sight distance on horizontal curves governs lateral bridge width.

REV. DATE: JUNE 30, 2015

FIGURE 5-M: LATERAL BRIDGE CLEARANCES



RAMP UNDERPASS



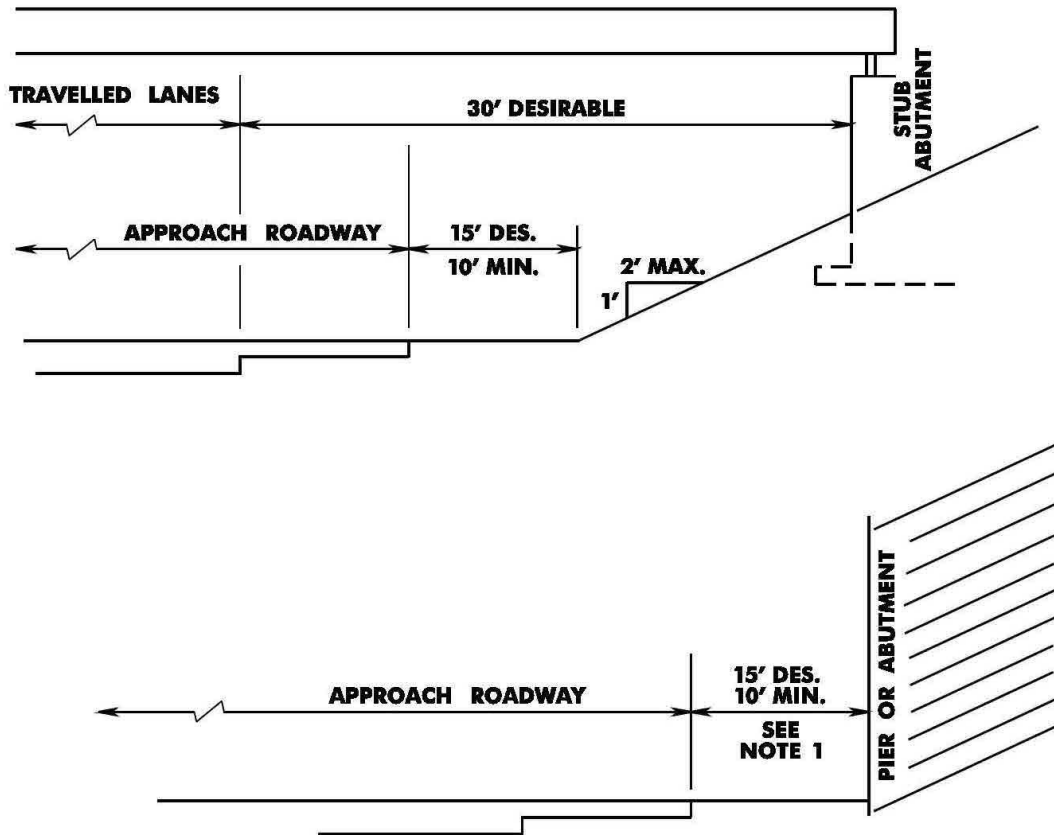
RAMP OVERPASS

NOTES:

1. Stopping sight distance on horizontal curves governs width of ramp (See Figure 4-A).
2. Stopping sight distance on horizontal curves governs offset to pier or abutment.
3. The controlling width of 26 feet on the ramp overpass is to allow for future lane closings for maintenance such as deck patching or replacement.

REV. DATE: JUNE 30, 2015

FIGURE 5-N: LATERAL BRIDGE CLEARANCES



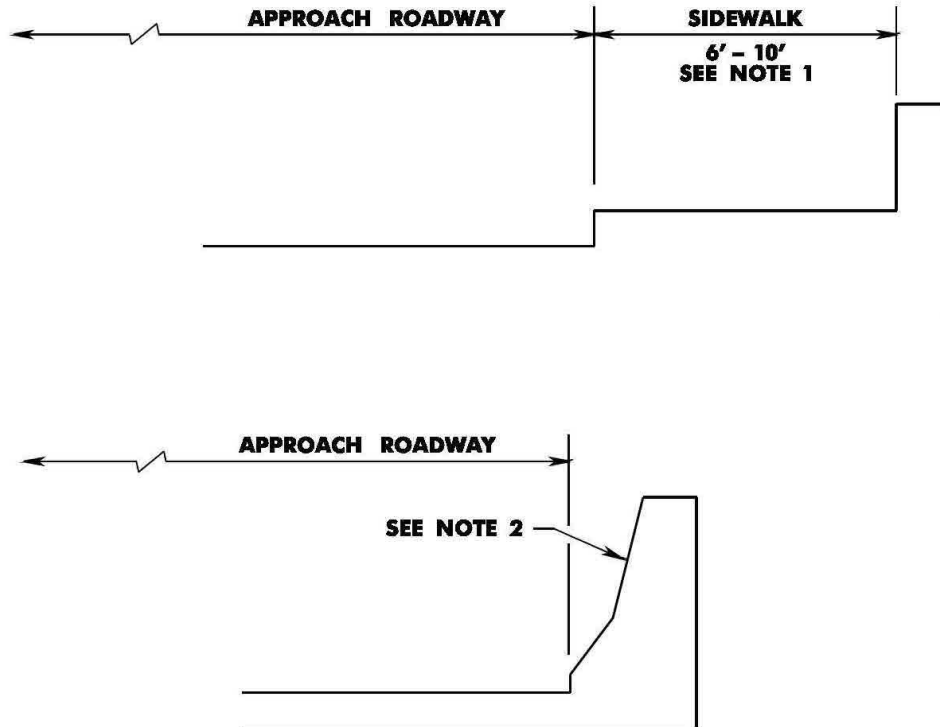
STATE HIGHWAY UNDERPASS

NOTE:

1. Stopping sight distance on horizontal curves governs (See Figure 4-A).

REV. DATE: JUNE 30, 2015

FIGURE 5-O: LATERAL BRIDGE CLEARANCES



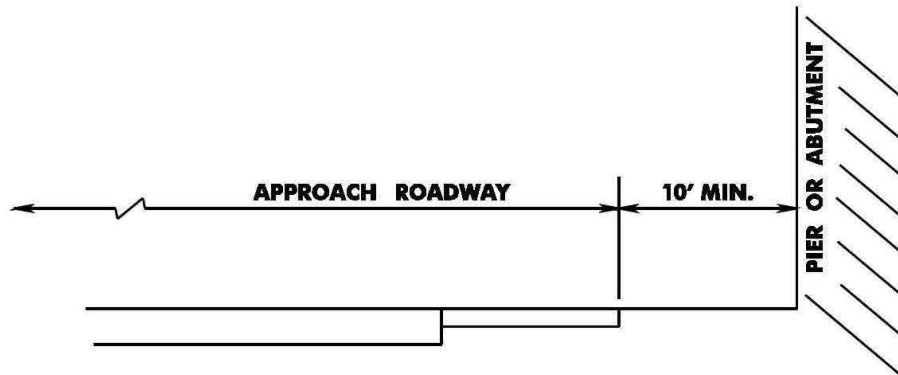
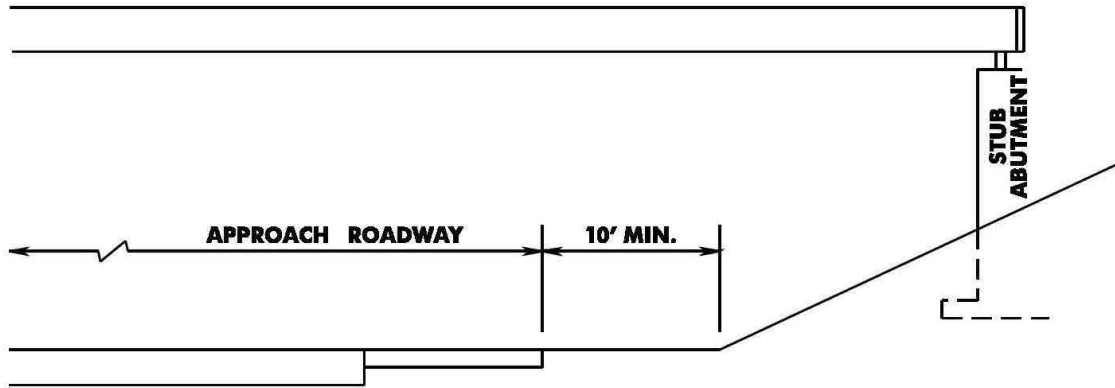
STATE HIGHWAYS AND LOCAL ROAD OVERPASS

NOTES:

1. Sidewalks should be provided on both sides of an overpass structure in urban areas, See Section 5.7.1.
2. Barrier curb parapet should be used only when a sidewalk cannot be justified on both sides of a roadway.

REV. DATE: JUNE 30, 2015

FIGURE 5-P: LATERAL BRIDGE CLEARANCES

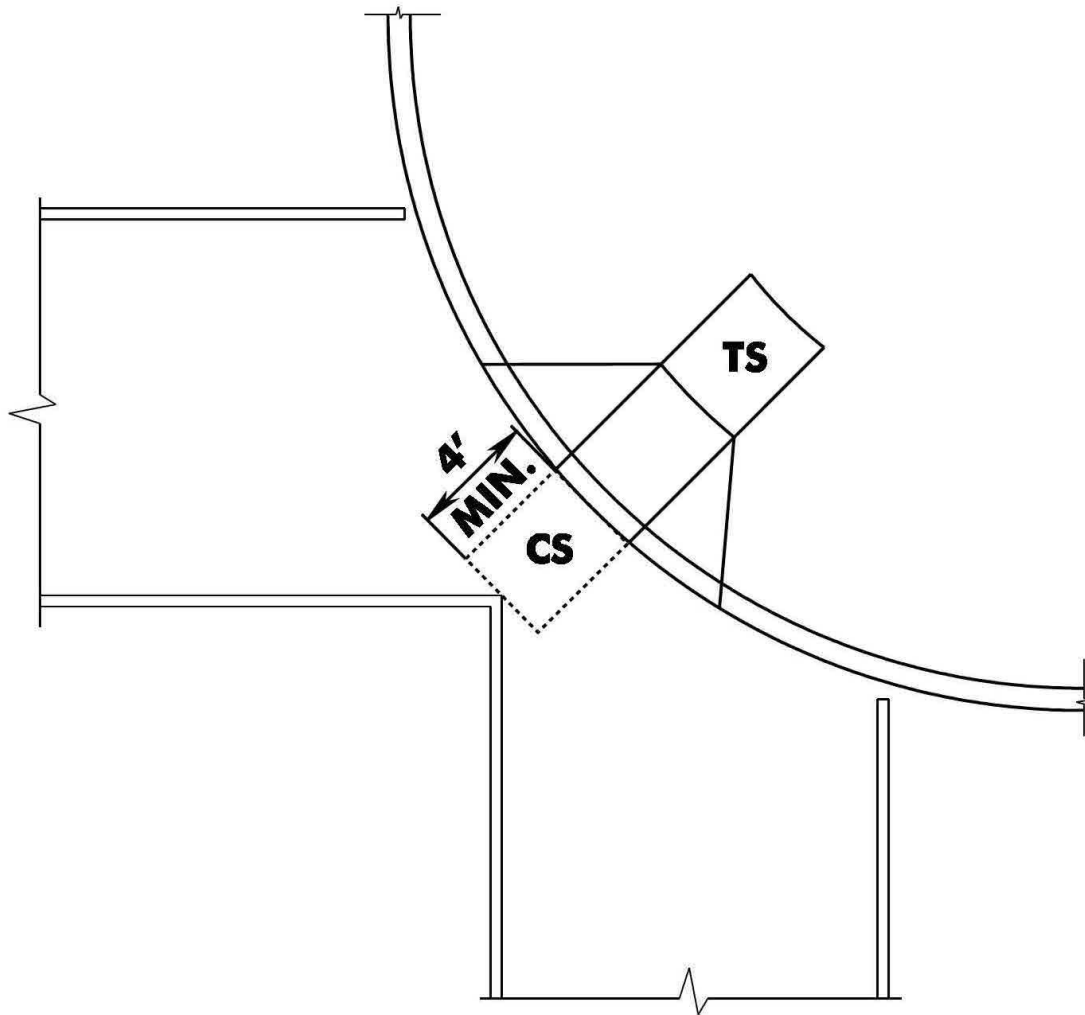


LOCAL ROAD OVERPASS

REV. DATE: JUNE 30, 2015

FIGURE 5-Q: CLEAR SPACE AT CORNER TYPE CURB RAMPS

TS = TURNING SPACE
CS = CLEAR SPACE



NOTE:

WHEN ONE CURB RAMP AT THE CENTER OF THE CORNER RADIUS (CORNER TYPE CURB RAMP) IS USED, THE BOTTOM OF THE CURB RAMP SHALL HAVE A CLEAR SPACE 4' MINIMUM OUTSIDE ACTIVE TRAFFIC LANES OF THE ROADWAY. THE CLEAR SPACE SHOULD BE WHOLLY WITHIN THE CROSSWALKS.

REV. DATE: JUNE 30, 2015

Section 6 - At Grade Intersections

6.1 General

Most highways intersect at grade. To minimize the resulting conflicts and to provide adequately for the anticipated crossings and turning movements, the geometric design of the intersection at grade must be given careful consideration.

Although intersections have many common factors, they are not subject to a set treatment, and must be looked upon on a case by case basis.

In varying degrees, four basic factors enter into the design of an intersection. These factors are traffic, physical, economic, and human.

- Traffic factors to be considered include:
 - Possible and practical capacities
 - Turning movements
 - Size and operating characteristics of vehicles
 - Control of movements at points of intersection
 - Vehicle speeds
 - Pedestrian Activity and movements
 - Bicycle Activity and movements
 - Bicycle operating space
 - Transit operations
 - Crash experience
- Physical factors which control intersection design and application of channelization are:
 - Topography
 - Abutting land use
 - Geometric features of the intersecting roadways
 - Traffic control devices
 - Safety features
- Economic factors, which are important and often controlling, include:
 - Cost of improvements
 - Effect on abutting businesses where channelization restricts or prohibits certain vehicular movements within the intersection area
- Human factors such as:
 - Driving, pedestrian, and bicyclist habits
 - Ability of drivers, pedestrians, and bicyclists to make decisions
 - Effect of surprise events
 - Decision and reaction times
 - Natural paths of movements must be considered
 - Types of pedestrians

An intersection may be extremely simple, or highly developed depending on the proper evaluation of the foregoing factors. In the redesign of an existing intersection, standards sometimes must be compromised due to the high cost of existing development or to the necessity of meeting rigid physical controls. In the design of a

new intersection, however, such controls frequently can be avoided by a shift in line or grade of one or both of the intersecting highways.

For further general discussion and details, see AASHTO – *A Policy on Geometric Design of Highways and Streets*.

6.2 General Design Considerations

6.2.1 Capacity Analysis

Capacity analysis is one of the most important considerations in the design of intersections. This is especially true in the design of at-grade intersections on urban streets and highways. Optimum capacities can be obtained when intersections include auxiliary lanes, proper use of channelization, and traffic control devices. Where these techniques are under consideration, it is necessary to consider pedestrian and bicycle safety and level of service. Reference is made to the *Highway Capacity Manual*, Transportation Research Board, for procedures in performing capacity computations.

6.2.2 Spacing

The spacing of intersections on major arterials is important to the capacity and safety of the roadway. In urban areas, the capacity of the arterial is determined by the capacity of the signalized intersections along the roadway. Ideally, signalized intersections should be located no closer than 1200 feet apart. In rural areas, the minimum spacing of intersections should be one half mile.

6.2.3 Alignment and Profile

Intersections are points of conflict between vehicles, bicycles, and pedestrians. The alignment and grade of the intersecting roads should permit drivers to discern and perform readily the maneuvers necessary to pass through the intersection safely and with minimum interference between vehicles. To these ends, the horizontal alignment should be as straight as possible and gradient as flat as practical. The sight distance should be equal to or greater than the minimum values for the specific intersection conditions. Sight distance is discussed later in this section.

1. Alignment

Regardless of the type of intersection, intersecting highways should meet at or nearly at right angles. Roads intersecting at acute angles require extensive turning roadway areas. Intersection angles less than 60 degrees normally warrant realignment closer to 90 degrees. Intersections on sharp curves should be avoided wherever possible because the superelevation and widening of pavements on curves complicate the intersection design. Furthermore, since traffic stripes are not normally carried through the intersection, there is no visual reference for the guidance of the driver through the intersection curve during adverse weather and visibility conditions, also see Section 8.4.1 D End Treatment.

2. Profile

Combinations of profile lines that make vehicle control difficult should be avoided. Substantial grade changes should be avoided at intersections, although it is not always feasible to do so. Adequate sight distance should be provided along both highways and across corners, even where one or both intersecting highways are on vertical curves.

The grades of intersecting highways should be as flat as practical on those sections that are to be used for storage space for stopped vehicles. A minimum storage

space for 2 vehicles, approximately 50 feet, should be provided for minor streets where stop sign control is employed and the approach grade is up towards the intersection. Such slopes should desirably be less than one percent and no more than 3 percent.

The profile lines and cross sections on the intersection legs should be adjusted for a distance back from the intersection proper to provide a smooth junction and proper drainage. Normally, the profile line of the major highway should be carried through the intersection, and that of the cross road adjusted to it. Intersections with a minor road crossing a multi-lane divided highway with narrow median and superelevated curve should be avoided whenever possible because of the difficulty in adjusting grades to provide a suitable crossing. Profile lines of separate turning roadways should be designed to fit the cross slopes and longitudinal grades of the intersection legs.

As a rule, the horizontal and vertical alignments are subject to greater restrictions at or near intersecting roads than on the open road. Their combination at or near the intersection must produce traffic lanes that are clearly visible to the motorists, bicyclists, and pedestrians at all times and definitely understandable for any desired direction of travel, free from sudden appearance of potential hazards, and consistent with the portions of the highway just traveled.

6.2.4 Cross Section

The cross section of the pavement surface within an intersection should be reviewed on a case-by-case basis. The development of the centerline profiles and edge of pavement profiles should flow smoothly through the intersection.

6.3 Sight Distance

6.3.1 General

There must be unobstructed sight along both roads at an intersection and across their included corner for distances sufficient to allow the operators of vehicles approaching the intersection or stopped at the intersection to observe pedestrians and cyclists and carry out whatever maneuvers may be required to negotiate the intersection. It is of equal importance that pedestrians be able to view and react to potential conflicts with vehicles.

Any object within the sight triangle high enough above the elevation of the adjacent roadways to constitute a sight obstruction should be removed or lowered. Such objects include but are not limited to cut slopes, hedges, bushes, tall crops, signs, buildings, parked vehicles, etc. Also check the vertical curve on the highway to see if it obscures the line of sight from the driver's eye (3.5 feet above the road) to the approaching vehicle (3.5 feet above the road) as per the sight distance determined in the next three sections.

6.3.2 Sight Distance for Bicycle Facilities

In general the sight distance required to see a bicycle is no greater than that to see a vehicle, so bicycle sight distance need not be calculated at intersections also used by vehicles. At locations where a separated bicycle facility crosses the roadway, or elsewhere where cyclists may enter or cross the roadway independent of vehicles, appropriate sight distance should be provided.

Vehicles parked near crosswalks create sight distance problems, and for this reason New Jersey State Statutes prohibit motor vehicle parking "within 25 feet of the nearest crosswalk or side line of a street or intersecting highway, except at alleys," and within 50 feet of a stop sign (Title 39:4-138). These relationships also apply to other locations where pedestrians are likely to cross (mid-block crosswalks, T-intersections, gaps in median barriers).

The parking setback distance can be reduced in locations where curb extensions have been provided to reduce crossing distance and increase the visibility of pedestrians as long as the provisions of Title 39 are also met.

6.3.3 Stop Control on Cross Street

Intersection designs should provide sufficient sight distances to avoid potential conflicts between vehicles turning onto or crossing a highway from a stopped position and vehicles on the through highway operating at the design speed.

As a minimum stopping sight distance must be provided. However, to enhance traffic operations, the recommended sight distance along the major roadway from Figure 6-A for various design vehicles to turn left, right or cross should be provided. Where the median width on a divided highway is 25 feet or greater, the crossing can be accomplished in 2 steps. The vehicle crosses the first pavement, stops within the median opening, and proceeds when a safe gap in traffic occurs to cross the second pavement. However, when the median width is less than that of a vehicle, the crossing must be made in one step and the median must be included as part of the roadway width (w).

6.3.4 Yield Control

When an intersection is controlled by a yield sign, the sight triangle is governed by the design speed on the main highway and that of the approach highway or ramp.

Suggested approach speeds on the yield controlled approach are 15 mph for urban conditions and 20 mph to 25 mph for rural conditions. Where two major highways intersect and one leg is controlled by a yield sign, the design speed on both highways should be used in determining the minimum sight triangle.

Figure 6-B illustrates the method for establishing the recommended sight triangle for yield controlled intersections.

The table "WITH ACCELERATION LANE" is from Table 9-3 of AASHTO - *A Policy on Geometric Design of Highways and Streets*. The distances shown in this table are less than the stopping sight distance for the same design speed. Since motorists slow down to some extent on approaches to uncontrolled intersections, the provision of a clear sight triangle with legs equal to the full stopping sight distance is not essential.

The recommended distances in the bottom table "WITHOUT ACCELERATION LANE" are from Table 9-12, of AASHTO - *A Policy on Geometric Design of Highways and Streets*. Yield -controlled approaches without acceleration lanes generally need greater sight distance than stop controlled approaches. If sufficient sight distance for yield control is not available, use of a stop sign instead of a yield sign should be considered. Another solution to where the recommended sight distance cannot be provided, consider installing regulatory signs to reduce the speed of the approaching vehicles.

6.3.5 Sight Distance at Signalized Intersections

Intersections controlled by traffic signals presumably do not require sight distance between intersecting traffic flows because the flows move at separate times.

However, drivers should be provided with some view of the intersecting approaches in case a crossing vehicle, bicycle or pedestrian violates the signal indication.

In addition, sight distance requirements for vehicles permitted to turn right on red signal indications must be considered. Line-of-sight should consider the effect of parked vehicles. As a minimum, stopping sight distance should be provided.

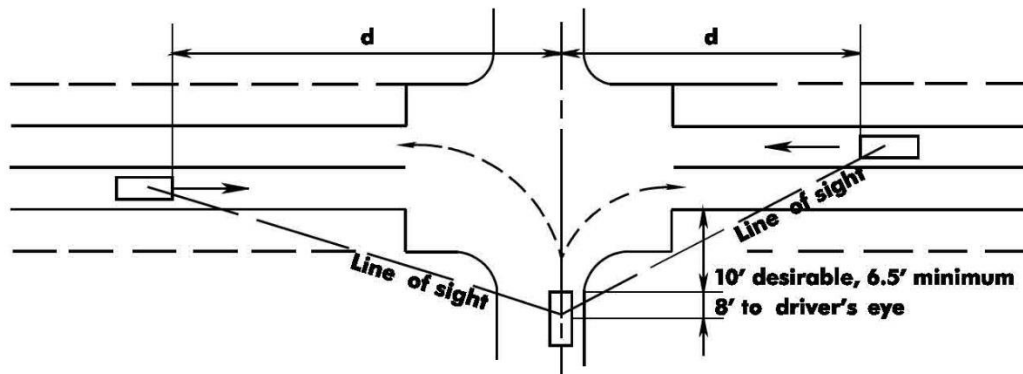
**FIGURE 6-A:
SIGHT DISTANCE AT INTERSECTIONS FOR LEFT, OR RIGHT
TURNING & CROSSING VEHICLES WITH STOP CONTROL**

Intersection Sight Distance(d) Stop Control on Minor Road Two Lane Highway						
Design Speed	Left-Turn			Right-Turn or Cross		
	P	SU	WB	P	SU	WB
25	280	350	425	240	315	385
30	335	420	510	290	375	465
35	390	490	595	335	440	540
40	445	560	680	385	500	620
45	500	630	760	430	565	695
50	555	700	845	480	625	775
55	610	770	930	530	690	850
60	665	840	1015	575	750	930
65	720	910	1100	625	815	1005
70	775	980	1185	670	875	1085

For highways with more than 2 lanes or when approach grade on minor road exceeds 3%, the distance (d) must be calculated using the formula: $d=1.47Vt_g$

Design Vehicle	Time Gap, t_g Left-Turn	Time Gap, t_g Right-Turn & Cross
P	7.5 (See Notes)	6.5 (See Notes)
SU	9.5 (See Notes)	8.5 (See Notes)
WB	11.5 (See Notes)	10.5 (See Notes)

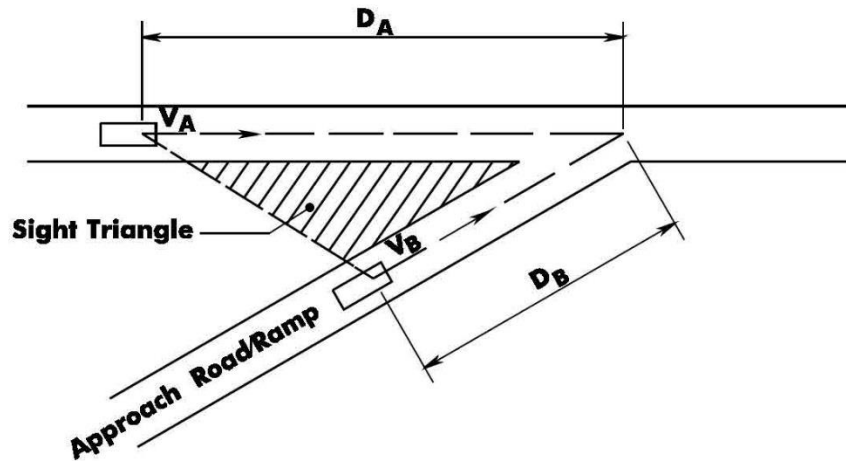
- Notes:**
1. For left turn or crossing add 0.5 sec. for P and 0.7 sec. for SU & WB for each additional lane crossed.
 2. For each percent the upgrade on minor road exceeds 3%, add 0.1 sec for right turn or crossing and 0.2 sec for left turn



Source: A policy on Geometric Design of Highways and Streets.

REV. DATE: JUNE 30, 2016

**FIGURE 6-B:
YIELD CONTROL**



WITH ACCELERATION LANE

DESIGN AND/OR APPROACH SPEED (mph) V_A OR V_B	DISTANCE (ft) D_A OR D_B
20	90
25	115
30	140
35	165
40	195
50	245
60	325
70	405

WITHOUT ACCELERATION LANE (See Note)

DESIGN SPEED (mph) V_A OR V_B	DISTANCE (ft) D_A	DISTANCE (ft) D_B
20	240	115
25	295	155
30	355	200
35	415	250
40	475	305
50	590	425
60	710	570
70	825	730

Note: For ramps and minor roads $D_B=82$ ft. For major roads use D_B from chart.

REV. DATE: JUNE 30, 2015

6.4 Vehicular Turning Movements

6.4.1 General

One of the primary concerns of intersection design is to provide adequately for left and right turning movements. The pavement and roadway widths of turning roadways at intersections are governed by the volumes of turning traffic and the types of vehicles to be accommodated.

6.4.2 Design Vehicles

The overall dimensions of the design vehicles considered in geometric design are shown in Table 2-2 of Section 2, General Design Criteria. The minimum turning radii of design vehicles could be obtained from *Geometric Design of Highways and Streets*, AASHTO. Figure 6-C provides general design guidelines.

The AASHTO figures should be used as guides in determining the turning radii at intersections and the widths of turning roadways. The principal dimensions affecting design are the minimum turning radius and those affecting the path of the inner rear tire, tread width and wheel base. The paths shown for the several design vehicles are established by the outer trace of the front overhang and the path of the inner rear wheel.

Due to the greater usage of the 8.5 foot wide, 48 foot long trailers, the designer should use the WB-62 turning template when designing new intersections or upgrading existing intersections. However, the designer is cautioned not to arbitrarily provide for these larger vehicles in the design of all intersections. For example, if the turning traffic is almost entirely passenger cars, it may not be cost-effective to design for large trucks, provided that an occasional large truck can turn by swinging wide and encroaching on other traffic lanes without disrupting traffic significantly. When selecting the appropriate design vehicle, the designer is encouraged to use vehicle classification counts. Also, the existing land use and/or zoning requirements may be useful in selecting the appropriate design vehicle. However, selection of the design vehicle will depend on the designer's judgment after all the conditions have been analyzed and the effect of the operation of larger vehicles has been evaluated.

It is very possible that the use of more than one design vehicle may be appropriate. As an example, the design of one quadrant of the intersection may warrant the use of a SU truck or passenger vehicle while another quadrant may warrant the use of the WB-62.

It is further recommended that all interstate and freeway ramp terminals be designed to accommodate the WB-62 design vehicle.

The use of the WB-62 design vehicle should also be considered when designing ingress and egress to commercial or industrial buildings along the state highways.

6.4.3 Turning Radii at Unchannelized Intersections

Where it is necessary to provide for turning vehicles within minimum space and slow speeds (less than 10 mph), as at unchannelized intersections, the minimum turning paths of the design vehicles apply.

Large turning radii allow vehicles to turn at higher speeds and increase the pedestrian crossing distance. Both factors affect pedestrian safety and comfort. Large radii consume space that could be used by waiting pedestrians, may make pedestrians less visible to drivers, and make vehicles more difficult for pedestrians to see. However,

curbs that protrude into the turning path of vehicles may result in larger vehicles damaging the curb and other street infrastructure, and endanger pedestrians standing at the curb. The design must balance these complex issues.

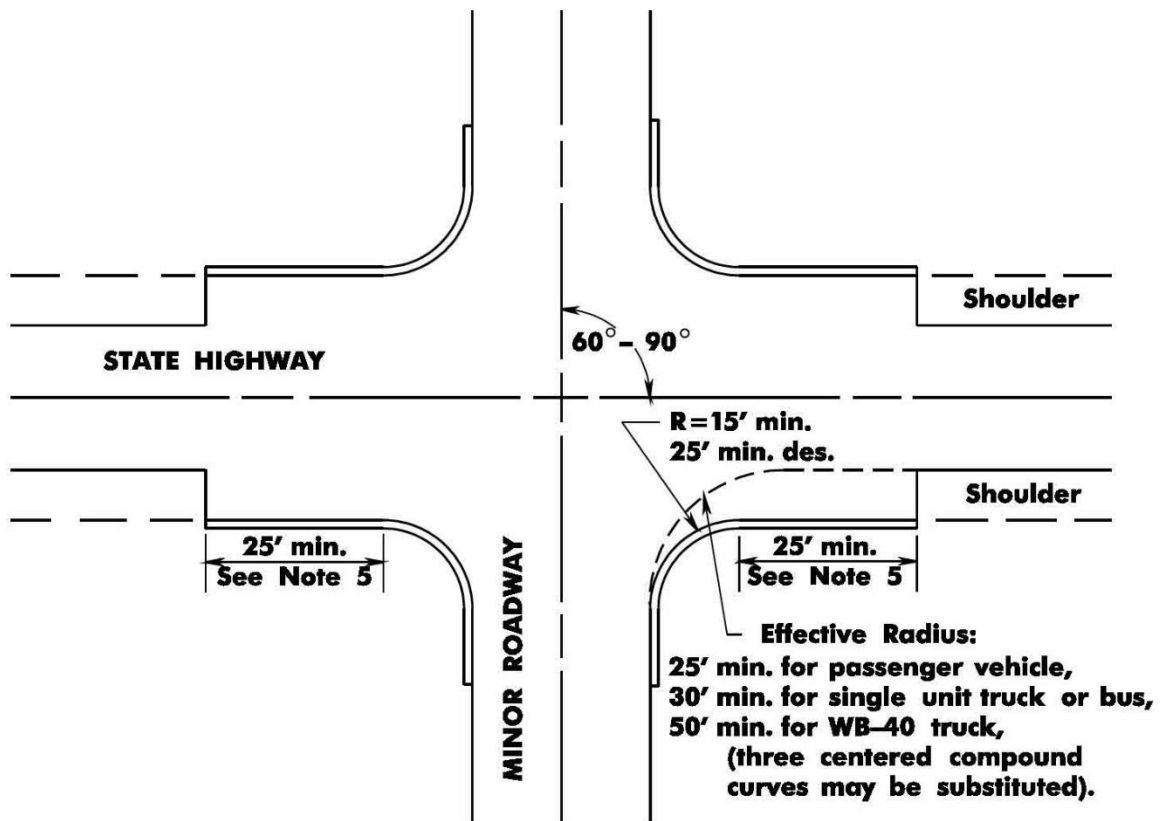
Turning radii design should be based on the “effective” turning radius of the design vehicle, rather than the actual corner radius see Figure 6-C. Where the travel lane abuts the curb, the effective and actual radius will be similar. Where there are parking lanes, bicycle lanes or a shoulder, the effective turning radius should be measured from the edge of the travel lane.

For most simple intersections with angle of turn of 90 degrees or less, a single circular arc joining the tangent edges of pavement provides an adequate design. Generally, an effective radius of 15 feet to 25 feet is adequate for passenger vehicles. Effective radii of 30 feet should be provided to allow an occasional truck or bus to turn without much encroachment. Larger effective radii should be provided where large truck combinations and buses turn frequently.

When provisions must be made for the larger truck units, and the angle of turn exceeds 90 degrees, a 3-centered compound curve may be used in lieu of a single circular arc with a large radius.

Figure 6-C indicates the minimum treatment at unchannelized intersections. See Traffic Calming Section for information on reduced turning radii as a traffic calming and pedestrian safety measure.

**FIGURE 6-C:
INTERSECTION TURNING RADII**



DESIGN GUIDELINES

1. Physical curb return should be clear of effective radius.
2. Truck volumes dictate the theoretical radius to be used. Where truck traffic is light, a SU truck radius should be used where possible.
3. A turning template for the appropriate design vehicle should be used to check the effective turn radii, especially for WB-50 and WB-62 trucks.
4. For intersection skew angles less than 60° , channelization should be provided.
5. Where turning volumes are high, auxiliary lanes through the intersection may be warranted.
6. Check applicable sight distances.

REV. DATE: JUNE 30, 2016

6.5 Channelization

6.5.1 General

Where the inner edges of pavement for right turns at intersections are designed to accommodate semi-trailer combinations, or where the design permits passenger vehicles to turn at speeds of 15 mph or more, the pavement area at the intersection may become excessively large for proper control of traffic. To avoid this condition, a corner island, curbed or painted, should be provided to form a separate turning roadway.

At-grade intersections having large paved areas, such as those with large corner radii and those at oblique angle crossings, permit and encourage undesirable vehicle movements, require long pedestrian crossings, and have unused pavement areas. Even at a simple intersection, appreciable areas may exist on which some vehicles can wander from natural and expected paths. Conflicts may be reduced in extent and intensity by a layout designed to include islands. For the design of 3-centered curves for right angle turns with corner islands and oblique angle turns with corner islands, see *A Policy on Geometric Design of Highways and Streets*, AASHTO, Figure 9-43 and Table 9-18, respectively.

6.5.2 Islands

An island is a defined area between traffic lanes for control of vehicle movements. Islands also provide an area for pedestrian refuge and traffic control devices. Within an intersection, a median or an outer separation is considered an island. This definition makes evident that an island is no single physical type; it may range from an area delineated by curbs to a pavement area marked by paint.

Islands generally are included in intersection design for one or more of the following purposes:

- Separation of conflicts;
- Control of angle of conflict;
- Reduction in excessive pavement areas;
- Regulation of traffic and indication of proper use of intersection;
- Arrangements to favor a predominant turning movement;
- Protection of pedestrians;
- Protection and storage of turning and crossing vehicles;
- Location of traffic control devices;
- Traffic calming and speed moderating purposes;

Islands generally are either elongated or triangular in shape, and are situated in areas normally unused as vehicle paths. The dimensions depend on the particular intersection design. Islands should be located and designed to offer little hazard to vehicles and bicycles, be relatively inexpensive to build and maintain, and occupy a minimum of roadway space but yet be commanding enough that motorists will not drive over them. Island details depend on particular conditions and should be designed to conform to the general principles that follow.

Curbed islands are sometimes difficult to see at night because of the glare from oncoming headlights or from distant luminaires or roadside businesses. Accordingly, where curbed islands are used, the intersection should have fixed-source lighting.

When various intersections are involved in a given project and the warrants are sufficiently similar, a common geometric design for each intersection should be used. This design approach will enhance driver expectancy. The designer should also refer to Part V of the *Manual on Uniform Traffic Control Devices for Streets and Highways* (MUTCD) for guidance.

Painted, flush medians and islands may be preferred to the curbed type under certain conditions including the following: in lightly developed areas; at intersections where approach speeds are relatively high; where there is little pedestrian traffic; where fixed-source lighting is not provided; and where signals, signs, or lighting standards are not needed on the median or island.

Islands may be grouped into 3 major functional classes: (1) channelizing islands designed to control and direct traffic movement, usually turning, (2) divisional islands designed to divide opposing or same-direction traffic streams, usually through movements, and (3) refuge islands to provide refuge for pedestrians. Most islands combine 2 or all of these functions:

1. Size

Island sizes and shapes vary materially from one intersection to another. Islands should be large enough to command attention. The smallest curbed island that normally should be considered is one that has an area of approximately 50 square feet for urban streets, and 75 square feet for rural intersections. However 100 square feet is the minimum desirable size for islands used in both urban and rural areas.

2. Approach-End Treatment

The approach end of a curbed island should be conspicuous to approaching drivers and should be physically and visually clear of vehicle paths, so that drivers will not veer from the island.

The nose offset should be 3 feet from the normal edge of through lane. Figure 6-D shows the recommended design details of curbed triangular islands under conditions of no shoulder on the approach roadways.

On highways with auxiliary lanes or shoulders, the corner islands should be offset the full auxiliary lane or shoulder width on both the main highway and the cross road as shown in Figure 6-E.

3. Divisional Islands

The most common type of elongated divisional island is the median island, for which a design guide is illustrated on Figure 6-F.

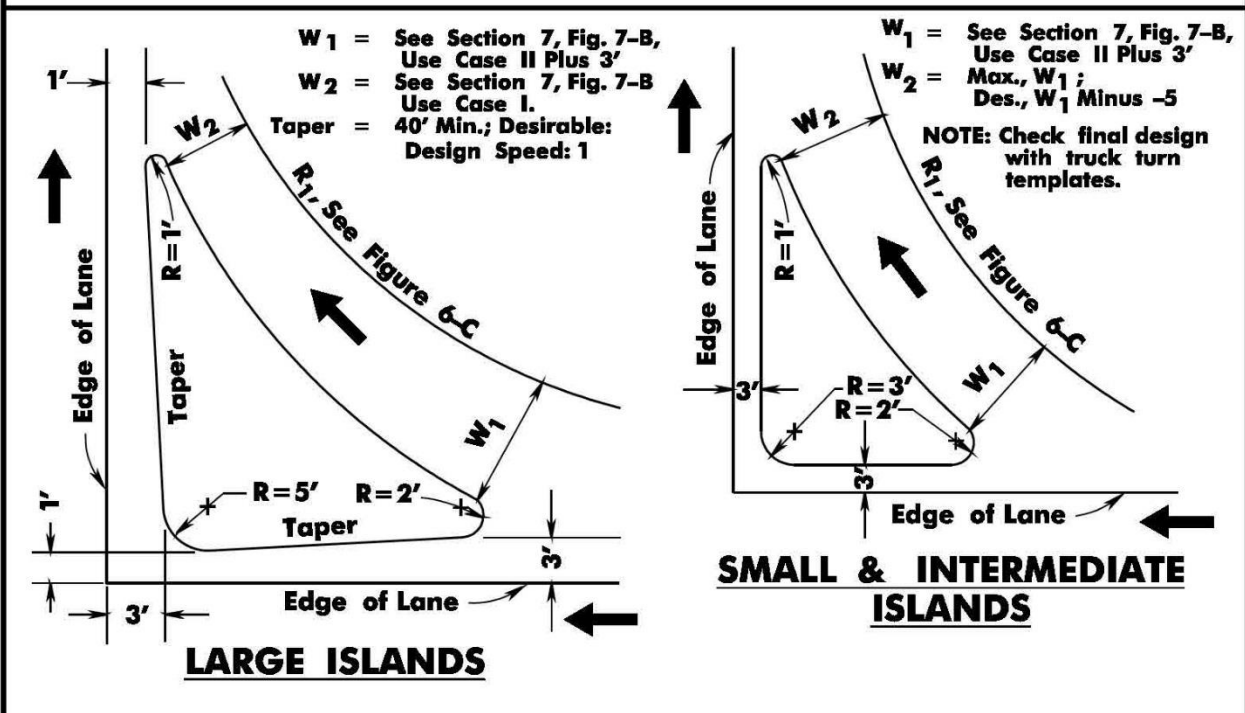
4. Bicycle Accommodation

Raised channelization islands should be located so as not to interfere with bicycle traffic.

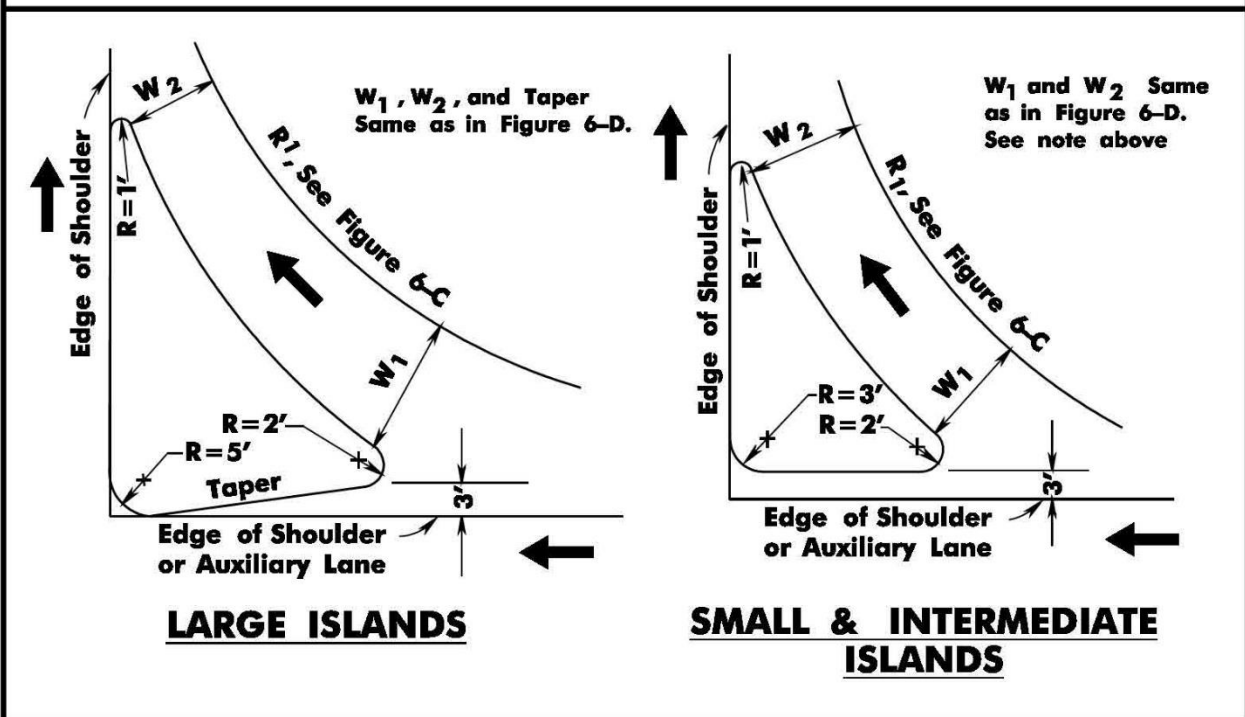
5. Pedestrian Accommodations

Along with their function of controlling and directing traffic movement (usually turns), and dividing traffic streams, islands may serve to enhance the safety and comfort of pedestrians crossing at intersections and midblock locations by providing a refuge. When channelizing islands are designed for this purpose, they are often termed "pedestrian crossing islands" or "median refuges."

**FIGURE 6-D:
ISLANDS WITH NO SHOULDERS**

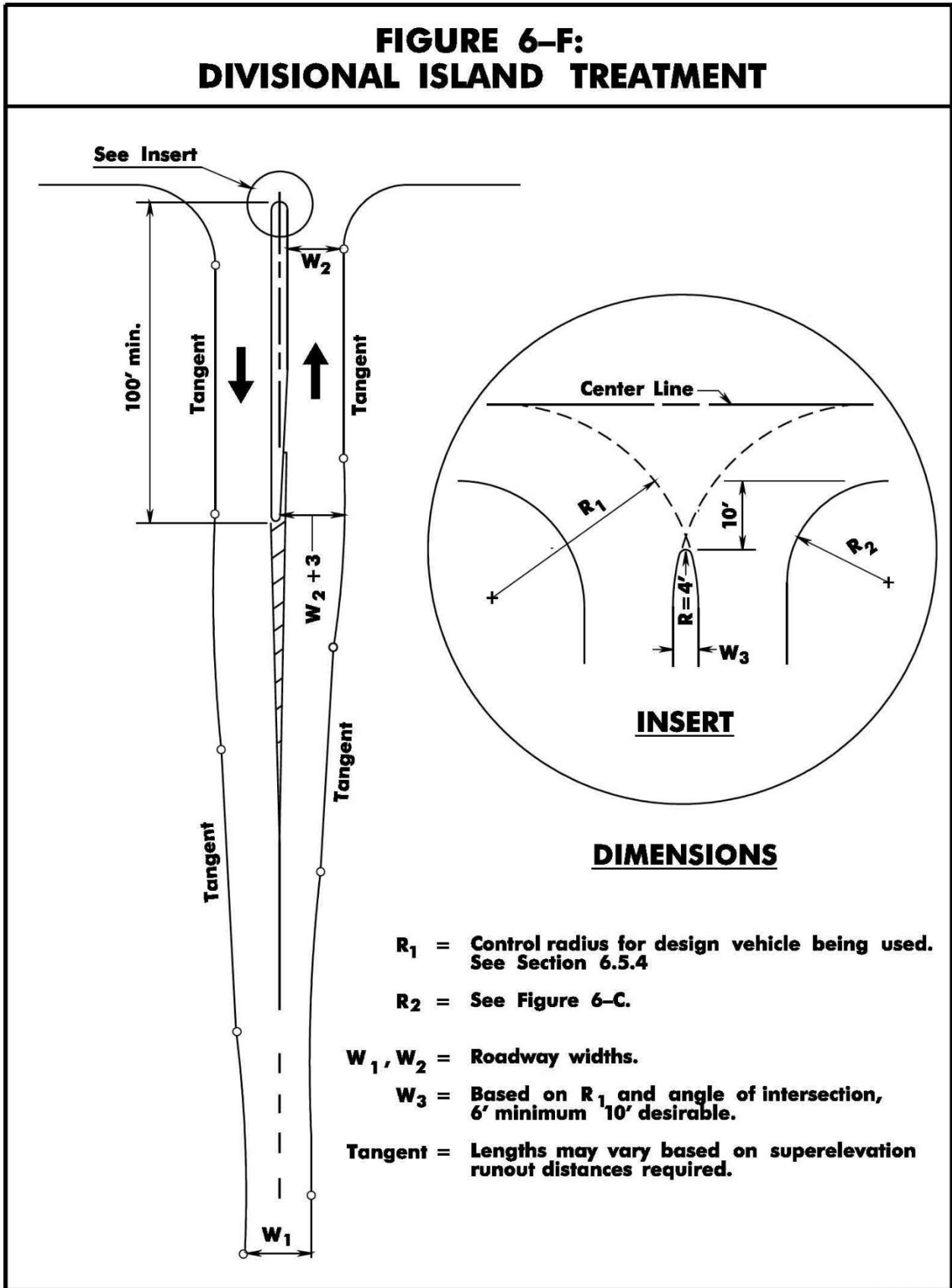


**FIGURE 6-E:
ISLANDS WITH SHOULDERS OR AUXILIARY LANES**



REV. DATE: JUNE 80, 2015

**FIGURE 6-F:
DIVISIONAL ISLAND TREATMENT**



REV. DATE: JUNE 30, 2016

6.5.3 Auxiliary Lanes

Auxiliary lanes at intersections serve a wide range of purposes including space for deceleration and acceleration, bus stops, increased capacity through an intersection, and storage for turning vehicles. The width of the auxiliary lanes shall be in accordance with Section 5.3.

Deceleration lanes are always advantageous, particularly on high speed roads, because the driver of a vehicle leaving the highway has no choice but to slow down on the through-traffic lane if a deceleration lane is not provided. On the other hand, acceleration lanes are not always necessary at stop controlled intersections where entering drivers can wait for an opportunity to merge without disrupting through traffic. Acceleration lanes are advantageous on roads with yield control and on all high volume roads even with stop control where openings between vehicles in the peak-hour traffic streams are infrequent and short.

When practical, an acceleration or deceleration lane should be of sufficient width and length to enable a driver to maneuver a vehicle onto it properly and once onto it, to make the necessary change between the speed of operation on the highway or street and the lower speed on the turning roadway. See Figure 6-H for desirable lengths of acceleration and deceleration lanes.

The capacity of a signalized intersection may be increased by adding an auxiliary lane to accommodate through traffic. The introduction of the auxiliary lane can usually be accomplished easily since it is effectively metered into the auxiliary lane. The merging of traffic from the auxiliary lane back into the through lane beyond the signal requires the auxiliary lane to be carried a distance beyond the stop line at the traffic signal to a point where the merging taper is introduced. The minimum length of the auxiliary lane in advance of and beyond the intersection including tapers shall be in accordance with Figure 6-G. The Bureau of Traffic Signal and Safety Engineering must approve the addition of an auxiliary lane to improve capacity at signalized intersections.

FIGURE 6-G: AUXILIARY LANE ADDITIONS AT SIGNALIZED INTERSECTIONS

LENGTH OF ADDITIONAL WIDENING IN ADVANCE OF INTERSECTION

L_1 = Length of auxiliary lane:

DESIGN SPEED (mph)	L_1 (Feet)
40 or less	315
45	375
50	435
55	485
60	570

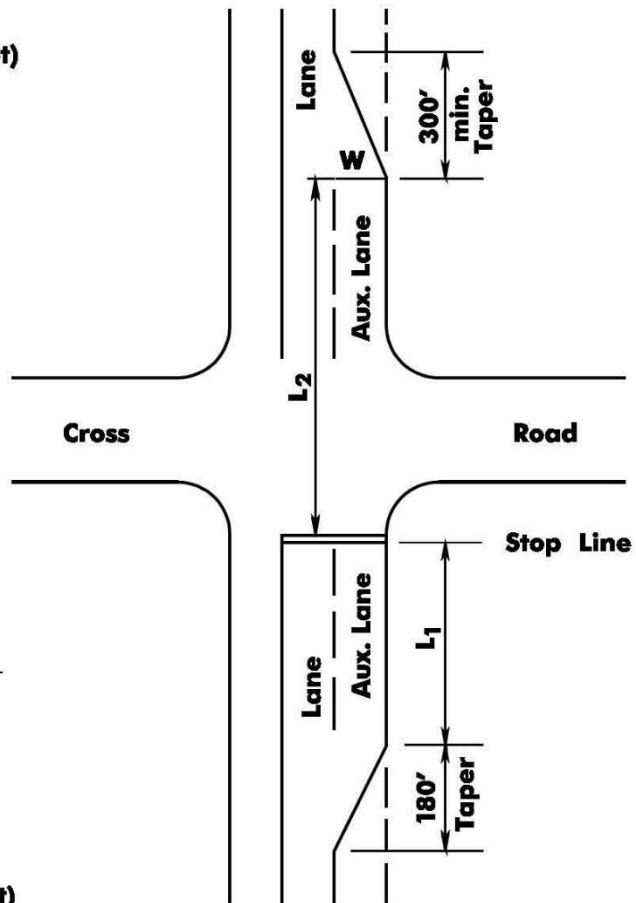
LENGTH OF ADDITIONAL WIDENING BEYOND INTERSECTION

L_2 = Length of auxiliary lane equals the greater of:

DESIGN SPEED (mph)	L_2 (Feet)
40 or less	380
45	560
50	760
55	960
60	1170

OR

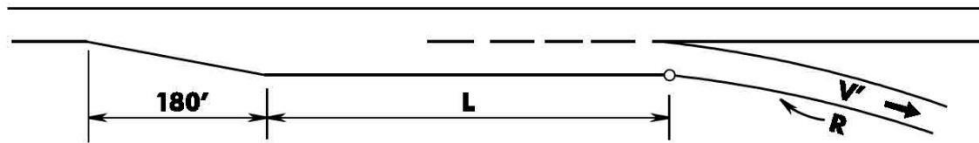
$L_2 = 12 \times$ Minimum green time G (sec.) for approach signal. If $G = 40$, then $L_2 = 12 \times 40 \text{ sec} = 480'$



REV. DATE: JUNE 30, 2015

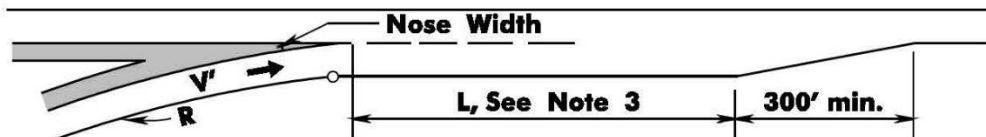
FIGURE 6-H: LAND SERVICE HIGHWAY AUXILIARY LANE LENGTHS

LENGTH OF DECELERATION LANES



HIGHWAY DESIGN SPEED MPH (V)	L = LENGTH OF DECELERATION LANE - FEET								
	FOR DESIGN SPEED OF EXIT CURVE - MPH (V')								
	STOP CONDITION	15 50' R	20 90' R	25 150' R	30 230' R	35 340' R	40 485' R	45 660' R	50 850' R
	FOR AVERAGE RUNNING SPEED ON EXIT CURVE - MPH (V'a)								
	0	14	18	22	26	30	36	40	44
30	235	200	170	140	—	—	—	—	—
40	320	295	265	235	185	155	—	—	—
50	435	405	385	355	315	285	225	175	—
60	530	500	480	460	430	405	350	300	240
65	570	540	520	500	470	440	390	340	280
70	615	590	570	550	520	490	440	390	340

LENGTH OF ACCELERATION LANES



HIGHWAY DESIGN SPEED MPH (V)	L = LENGTH OF ACCELERATION LANE - FEET								
	FOR DESIGN SPEED OF ENTRANCE CURVE - MPH (V')								
	STOP CONDITION	15 50' R	20 90' R	25 150' R	30 230' R	35 340' R	40 485' R	45 660' R	50 850' R
	AND INITIAL SPEED - MPH (V'a)								
	0	14	18	22	26	30	36	40	44
30	180	140	—	—	—	—	—	—	—
40	360	300	270	210	120	—	—	—	—
50	720	660	610	550	450	350	130	—	—
60	1,200	1,140	1,100	1,020	910	800	550	420	180
70	1,620	1,560	1,520	1,420	1,350	1,230	1,000	820	580

- NOTES:**
- Minimum radii shown are for intersection curves. For design speeds of more than 40 mph, use values for open highway curves.
 - These tables apply to flat grades of 2% or less. For grades steeper than 2%, use the adjustments for grade in Table 10-4 of the source shown below.
 - "L" may start back on the curvature of the ramp where the entrance radius is equal to or greater than 1,000 feet and the motorist on the ramp has an unobstructed view of traffic on the through lanes to his left, but parallel section must be 300 from where the nose width equals 2 feet.

Source: A Policy on Geometric Design of Highways and Streets.

REV. DATE: APRIL 13, 2018

6.5.4 Median Openings

Median openings on divided roadways are provided to permit intended movements only. Figures 6-I and 6-J show the application of grass median and concrete barrier curb median openings, respectively, to control the various types of movements along a divided roadway.

The length of the median opening desirably should equal the full roadway width of the cross road, shoulder to shoulder plus 10 feet on both sides to accommodate a crosswalk, except where the median extends into the sidewalk/crosswalk area as described below. The control radius (R1) should also be considered in determining the minimum length of median opening. The control radius (R1) is determined by the design vehicle as follows:

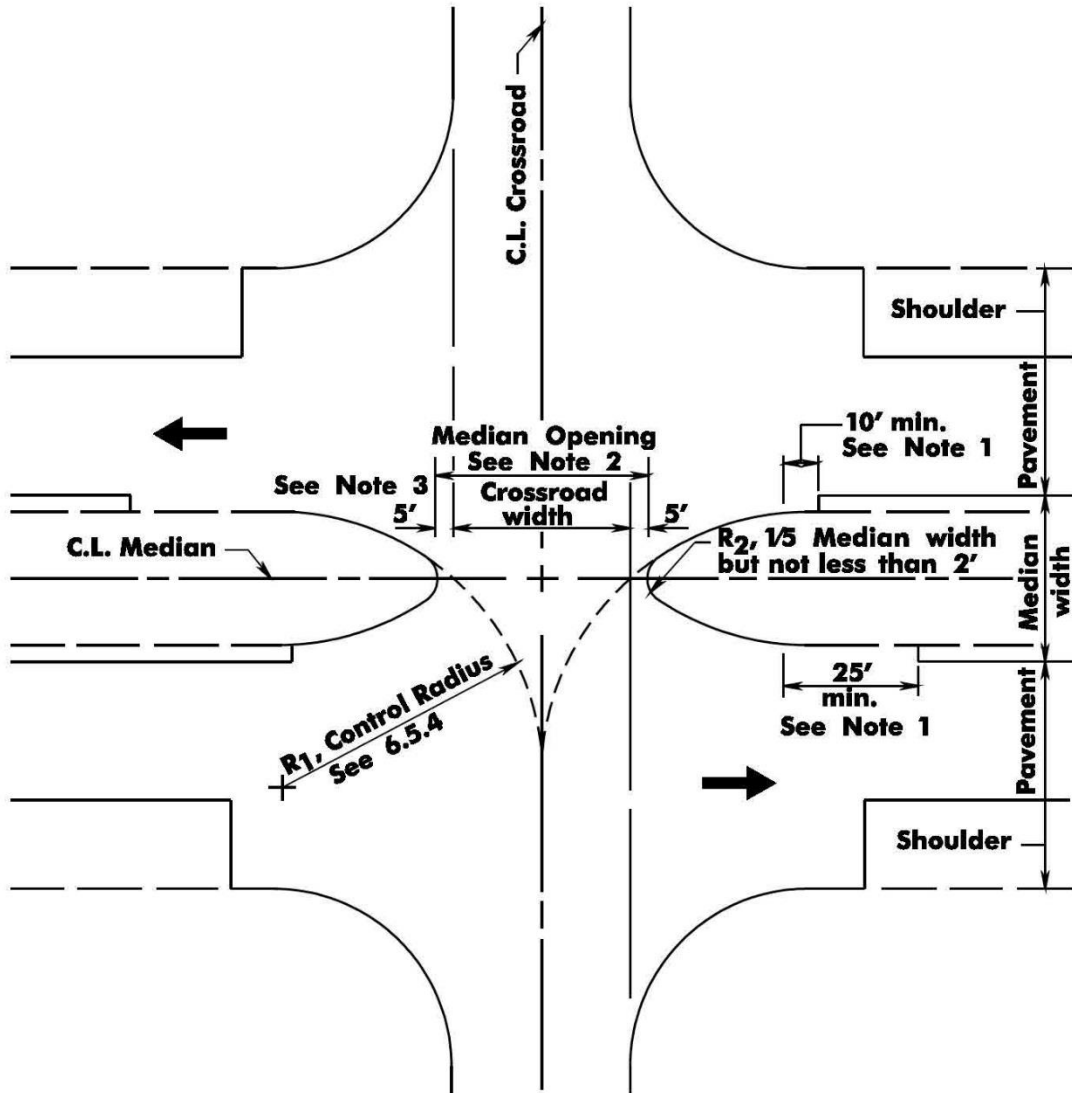
Design Vehicle	Control Radius	Description
P and SU-30	40 feet	A control radius of 40 feet accommodates P design vehicles suitably and occasional SU-30 design vehicles with some swinging wide
SU-30, SU-40, BUS, WB-40	50 feet	A control radius of 50 feet accommodates SU-30 design vehicles and occasional SU-40, BUS, and WB-40 design vehicles with some swinging wide
SU-40, WB-40, WB-50, WB-62	75 feet	A control radius of 75 feet accommodates SU-40, WB-40, WB-50, and WB-62 design vehicles with minor swinging wide at the end of the turn
WB-62, WB-67	130 feet	A control radius of 130 feet accommodates WB-62 design vehicles and occasional WB-67 vehicles with minor swinging wide at the end of the turn

Where possible, medians that are at least 6 feet wide may be designed to provide a safe refuge location for pedestrians. At signalized intersections, where medians are used as a pedestrian refuge, pedestrian push buttons should be used in the median where signal timing does not allow sufficient time for pedestrians to cross the entire roadway in one cycle. Barrier curb medians should not be used as a refuge for pedestrians.

The use of a 40 feet minimum length of opening without regard to the width of median, the cross road width, pedestrian traffic or the control radius should not be considered. The 40 feet minimum length of opening does not apply to openings for U-turns except at very minor crossroads. Consult A Policy on Geometric Design of Highways and Streets, AASHTO, current edition, for the design of U-turn median openings.

On urban divided roadways, median openings for U-turns should not be provided. U-turn movements may be permitted at signalized intersections where there is sufficient pavement width to accommodate the movement. Provisions for U-turns should be made on rural divided roadways where intersections are spaced in excess of one half mile apart. Median widths in such cases should be at least 20 feet and desirably 30 feet to provide adequate protection for the vehicle executing the U-turn movement from the median. It is highly desirable to construct a median left-turn lane in advance of the U-turn opening to eliminate stopping on the through lanes.

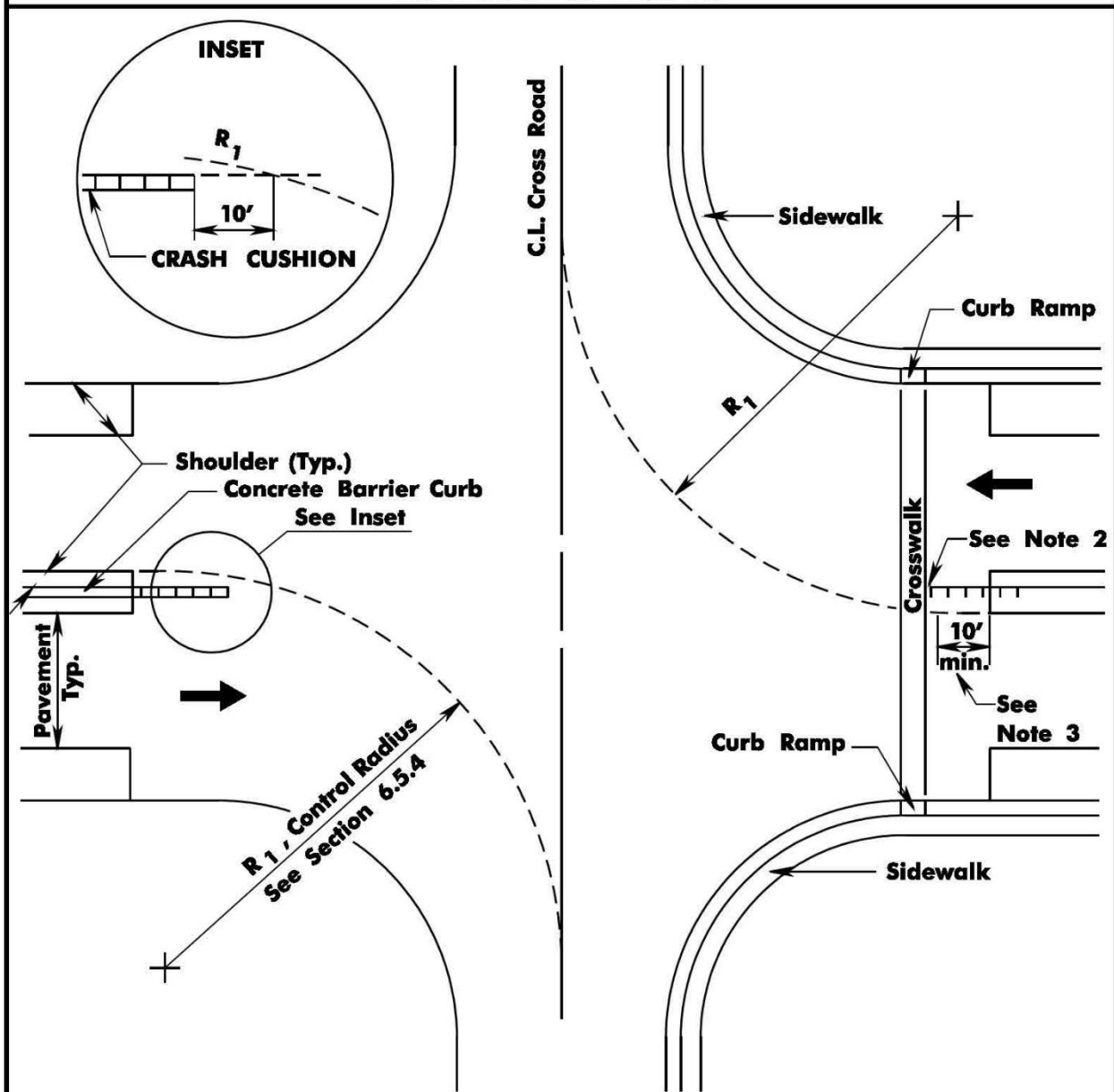
**FIGURE 6-I:
GRASS MEDIAN OPENING**



- NOTES:**
1. Where lane and shoulder pavement are different, use the minimum offsets shown above.
 2. In no case shall the length of the median opening be less than 40 feet.
 3. Provide 10 feet where there is a marked or unmarked pedestrian crosswalk. As an alternate, provide median cut through for pedestrian traffic.

REV. DATE: JUNE 30, 2015

**FIGURE 6-J:
NEW LOCATIONS OF CONCRETE BARRIER CURB AT
MEDIAN OPENING**



- NOTES:**
1. Use control radius to set the location of the **C.RASH CUSHION**.
 2. Adjust the location of the **C.RASH CUSHION** so it does not interfere with marked or unmarked crosswalks.
 3. Where lane and shoulder pavement are different, use the minimum offset shown above to set beginning of inside shoulder.
 4. Use a **C.RASH CUSHION** where posted speed is greater than 40 mph.
 5. See Section 8 for discussion of end treatments for concrete barrier curb.

REV. DATE: JUNE 30, 2015

6.5.5 Median Openings for Emergency Vehicles

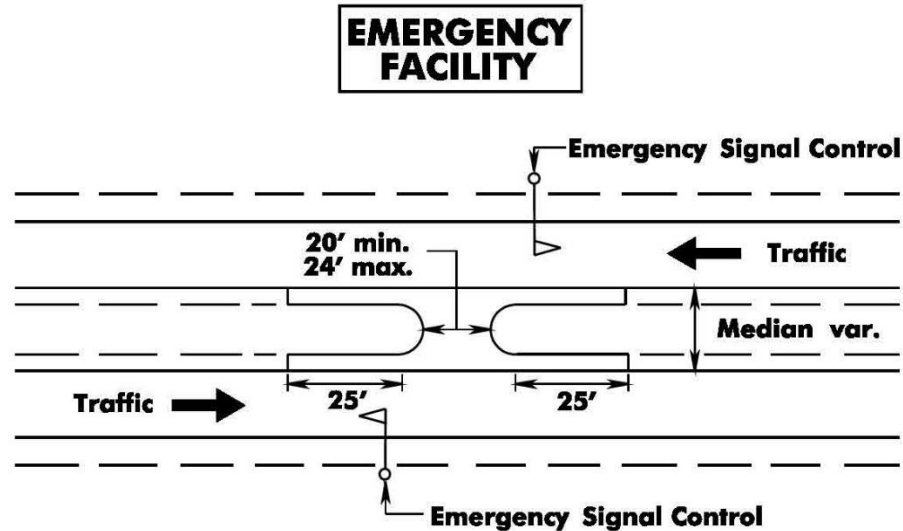
Although it is desirable to require all U-turns by official vehicles to be accomplished at intersections or interchanges, experience demonstrates that some emergency median openings are necessary for proper law enforcement, fire-fighting apparatus, ambulances and maintenance activities. Where median openings are provided for use by official vehicles only, they shall be limited in number and carefully located in accordance with this section and the needs of local authorities.

On freeways and Interstate highways where the spacing of interchanges is greater than approximately 3 miles, a U-turn median opening may be provided at a favorable location halfway between the interchanges. Where the spacing of interchanges is greater than about 6 miles, U-turn median openings may be provided so that the distance between such openings or interchange is not greater than about 3 miles.

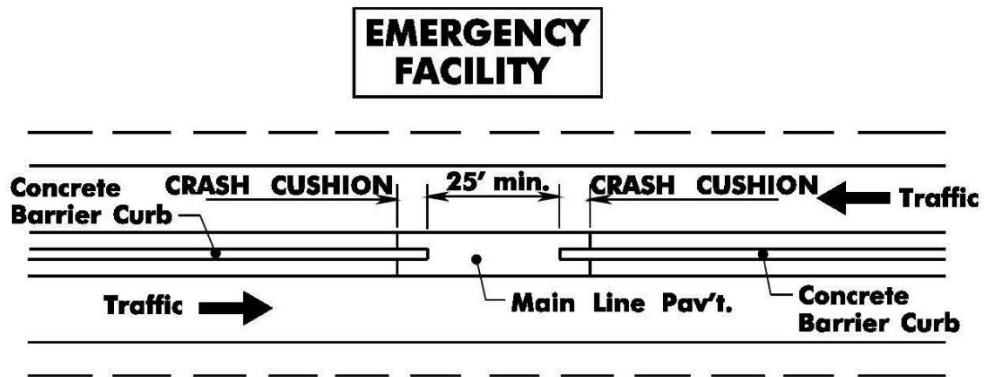
In general, U-turn median openings should not be provided on urban freeways due to the close spacing of interchanges. Due to the close proximity of intersections on divided arterials, emergency U-turn median openings are not normally provided. However when emergency facilities are located between intersections, there may be a need for direct access to the highway.

See Figures 6-K & 6-L for typical emergency median opening treatments.

**FIGURE 6-K:
EMERGENCY MEDIAN OPENINGS ON LAND-SERVICE
ROADWAYS**



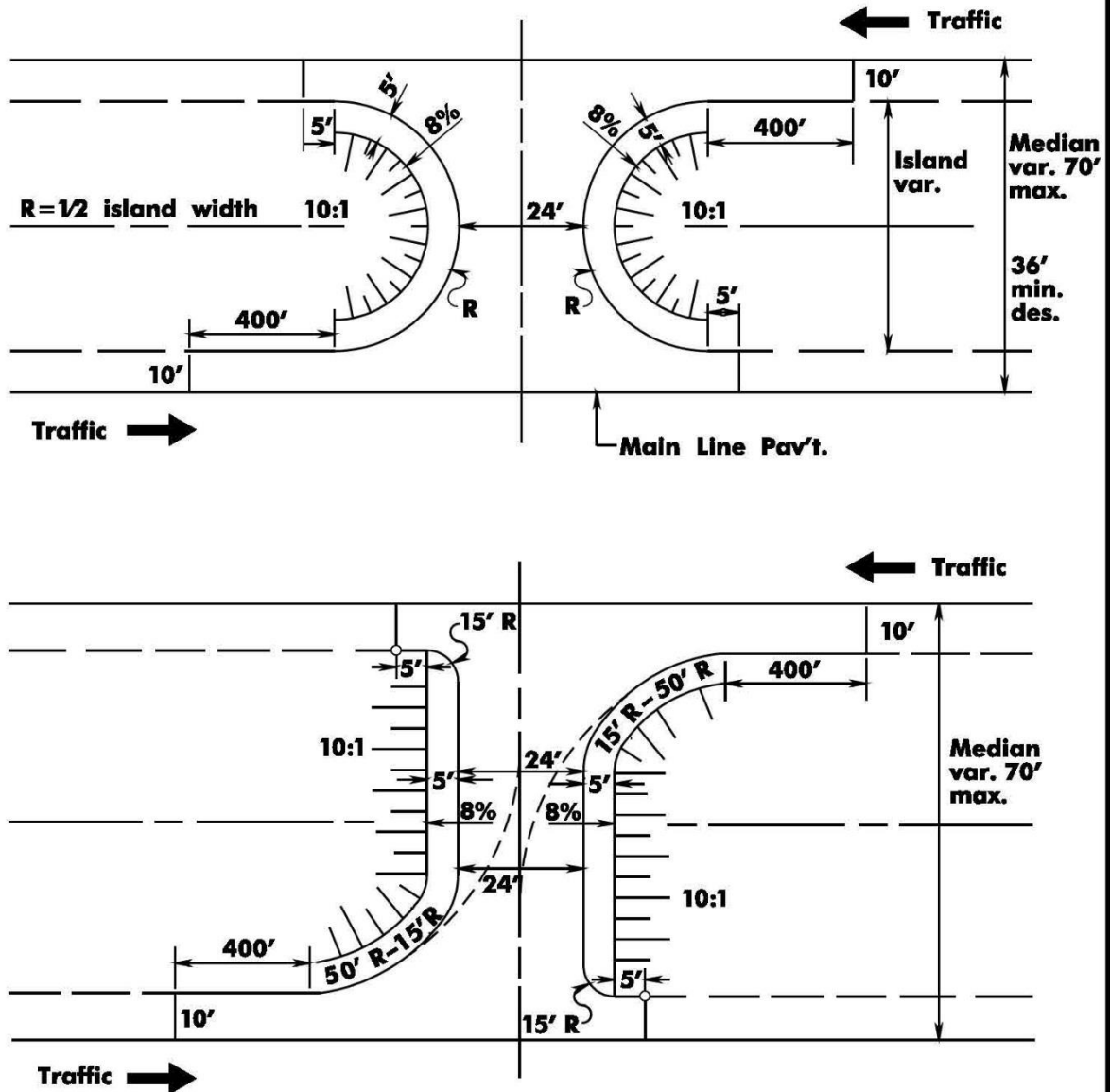
- NOTES:**
1. Grading to be done at 8% around median opening.
 2. If necessary, ponding water is to be eliminated by providing an "E" inlet in the median C.L. and connecting to existing drainage line.
 3. Adequate stopping sight distance must be available.



- NOTES:**
1. Emergency signal control may be placed in concrete barrier curb, or outside the shoulder area as shown above.
 2. Adequate stopping sight distance must be available.
 3. As an alternative to using a CRASH CUSHION, a remote controlled "Barrier Gate" may be used to provide a 26' or 40' opening in concrete barrier curb during emergency response times.

REV. DATE: JUNE 30, 2015

**FIGURE 6-L:
EMERGENCY MEDIAN OPENINGS ON FREEWAYS
OR INTERSTATE HIGHWAYS**



- NOTES:**
1. Ponding of runoff is to be eliminated by conventional means.
 2. The median opening is to be located where adequate stopping sight distance may be provided.
 3. The median opening should be located $\frac{1}{2}$ mile from any freeway underpass and at least one mile from any ramp terminal.

REV. DATE: JUNE 30, 2016

6.6 Median Left-Turn Lane

6.6.1 General

A median lane is provided at an intersection as a deceleration and storage lane for vehicles turning left to leave the highway. Median lanes may be provided at intersections and other median openings where there is a high volume of left-turns, or where vehicular speeds are high on the main roadway. Median lanes may be operated with traffic signal control, with stop signs, or without either, as traffic conditions warrant. Figure 6-M shows a typical median left-turn lane.

6.6.2 Lane Width

Left-turn lanes with median curbing should be 11 feet wide and desirably 14 feet wide. The lane width is measured from the curb face to the edge of through lane. Left-turn lanes without median curbing should be at least 11 feet wide and preferably 12 feet wide.

Median widths of 20 feet to 25 feet or more are desirable at intersections with a single left-turn lane, but widths of 15 feet to 18 feet are acceptable.

6.6.3 Length

The total length of the left-turn lane is the sum of storage length and entering taper.

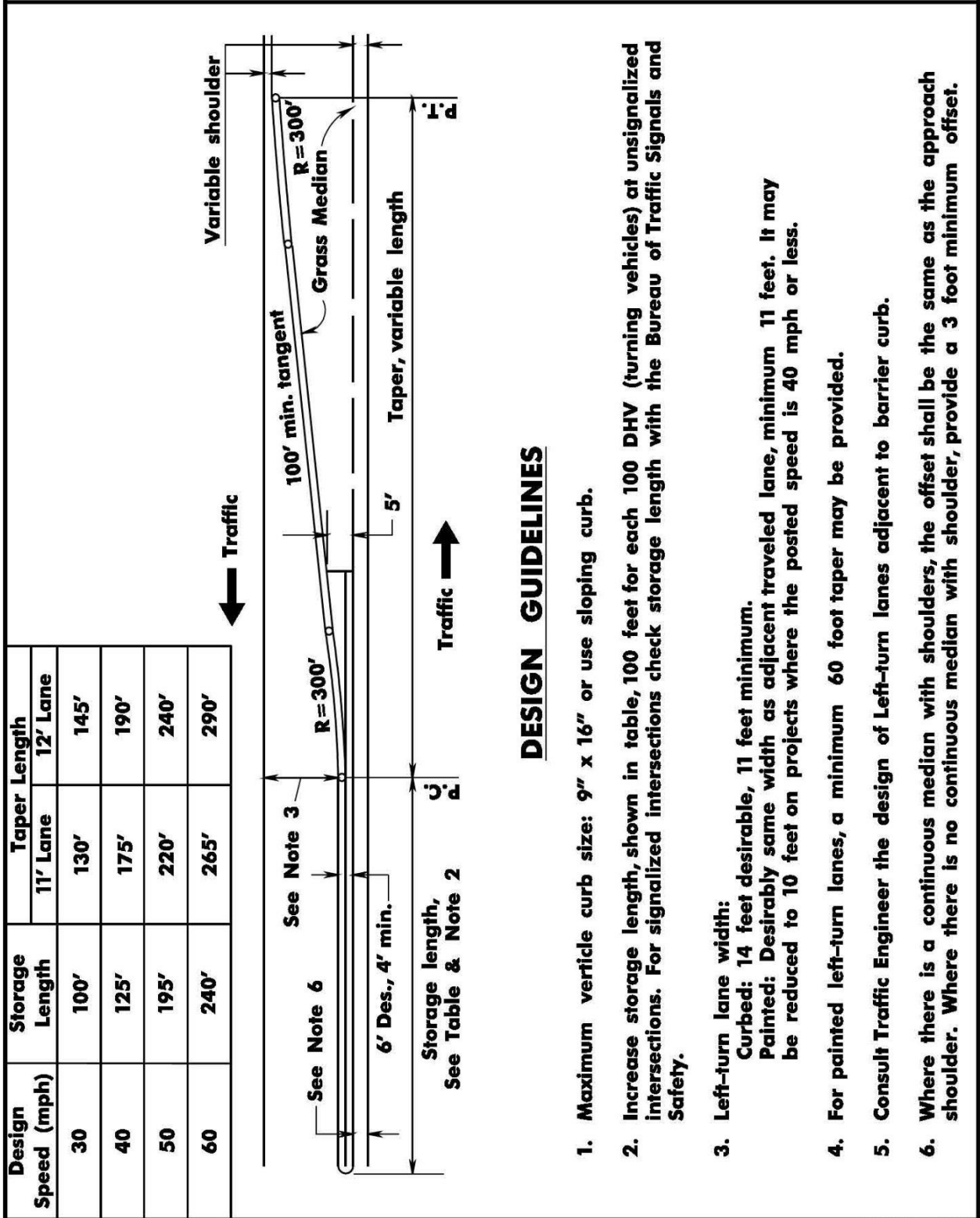
- **Storage Length**

The median left-turn lane should be sufficiently long to store the number of vehicles likely to accumulate during a critical period. The storage length should be liberal to avoid the possibility of left-turn vehicles stopping in the through lanes (see Figure 6-M).

- **Taper**

The entering taper treatment is illustrated in Figure 6-M.

**FIGURE 6-M:
TYPICAL LEFT-TURN SLOT**



DESIGN GUIDELINES

1. Maximum vehicle curb size: 9" x 16" or use sloping curb.
2. Increase storage length, shown in table, 100 feet for each 100 DHV (turning vehicles) at unsignalized intersections. For signalized intersections check storage length with the Bureau of Traffic Signals and Safety.
3. Left-turn lane width:
 Curbed: 14 feet desirable, 11 feet minimum.
 Painted: Desirably same width as adjacent traveled lane, minimum 11 feet. It may be reduced to 10 feet on projects where the posted speed is 40 mph or less.
4. For painted left-turn lanes, a minimum 60 foot taper may be provided.
5. Consult Traffic Engineer the design of Left-turn lanes adjacent to barrier curb.
6. Where there is a continuous median with shoulders, the offset shall be the same as the approach shoulder. Where there is no continuous median with shoulder, provide a 3 foot minimum offset.

REV. DATE: JUNE 30, 2015

6.7 Continuous Two-Way Left-Turn Median Lane

6.7.1 General

A continuous two-way left-turn median lane provides a common space for speed changes and storage for left-turn vehicles traveling in either direction and allows turning movements at any location along a two-way roadway.

Continuous two-way left-turn median lanes are an effective means of providing an increased level of service on many urban arterials. They are especially effective in locations of strip commercial development and frequent driveway openings experiencing moderate left-turn demands.

Since it is possible for vehicles traveling in opposite directions to enter the two-way left-turn lane simultaneously, sufficient stopping sight distance must be provided to permit vehicles to stop. Table 6-1 provides the desirable stopping sight distance as related to design speeds that are applicable to two-way left-turn lanes.

Table 6-1
Desirable Stopping Sight Distances for
Two-Way Left-Turn Lanes

Design Speed (mph)	Stopping Sight Distance (feet)
30	400
35	500
40	610
45	720
50	850
55	990
60	1140

The length of crest vertical curve can be computed by the following formulas. The formulas are based on the height of the driver's eyes of 3.5 feet and of an object 2 feet on the road, which is equivalent to the headlight height above the roadway.

When S is greater than L, $L=2S-(2158/A)$

When S is less than L, $L=AS^2/2158$

S= Stopping sight distance from Table 6-1, in feet.

L= Length of vertical curve, in feet.

A= Algebraic difference in grade, in percent.

If there is adequate roadway lighting present, the object height may be increased to 4.25 feet (top of vehicle), therefore, substitute "3093" for "2158" in the previous formulas. The vertical curve length on the highway should also be checked by Figure 4-I and use the greater of the two "L" values when designing the vertical curve.

Figure 6-N shows a typical two-way left-turn median lane.

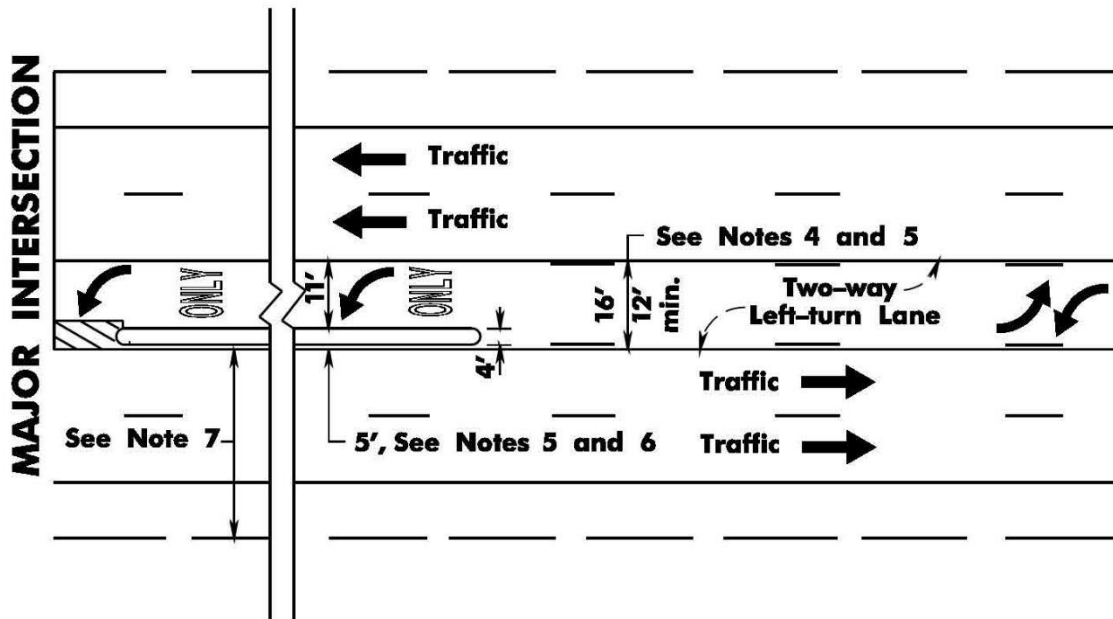
6.7.2 Lane Width

Lane widths for continuous two-way left turn median lanes range from 12 feet to 16 feet. The wider pavement width should be used only when raised islands are provided at major intersections with high left-turn demands. A median lane width of 12 feet is the minimum where raised islands are not provided at major intersections.

6.7.3 Cross Slope

Generally the crown line should be located in the center of the median turn lane. The slope of pavement from the crown line should be the same as the cross slope on the through lane adjacent to the median lane.

**FIGURE 6-N:
TWO-WAY LEFT-TURN LANE**



DESIGN GUIDELINES

1. For desirable & minimum stopping sight distance requirements, See Table 6-1.
2. For proper signing and paint striping consult the "Manual On Uniform Traffic Control Devices".
3. Two-way left-turn lanes are not recommended where the number of thru lanes exceeds two lanes in each direction.
4. Divisional Island used only when median width is at least 16 feet wide.
5. Where the design speed is equal to or greater than 50 mph, the recommended paint line offset to divisional island is two feet, which would increase the two-way left-turn lane width by one foot.
6. Divisional Island with a crosswalk opening used as a pedestrian refuge should be 6 feet wide.
7. Where there is only one through lane the minimum width shall be 20 feet (where there is a curbed island).

REV. DATE: JUNE 30, 2015

6.8 Jughandles

6.8.1 General

A "jughandle" is an at-grade ramp provided at or between intersections to permit the motorists to make indirect left turns and/or U-turns. Around-the-block designs that use interconnecting local street patterns to accomplish indirect left turns or U-turns are not considered "jughandles".

These ramps exit from the right lane of the highway in advance of the intersection, or past the intersection and convey traffic across the main highway under traffic signal control. This movement eliminates all turns within active traffic lanes and, in addition to providing greater safety, reduces delays to the through traffic that left turning vehicles usually create.

6.8.2 Ramp Width

Ramp widths are based on Figure 7-B. The minimum width for a one lane ramp should not be less than 22 feet. Ramps may have more than one lane when greater traffic volumes are anticipated.

6.8.3 Access Control

In order to provide safe and efficient traffic operations on land service highways, the interior of all jughandles shall be acquired. In addition, no access is permitted on the outside of all jughandles including the entire length of acceleration and deceleration lanes, excluding the taper length, see Figures 6-O, 6-P, and 6-Q. It is desirable that no access is permitted along the taper length of acceleration and deceleration lanes.

When a deceleration lane extends through an intersection and the deceleration lane accommodates both the right turn move onto the cross street and the right turn onto the jughandle past the intersection; the access restriction that applies in advance of the intersection is "corner clearance", see Figure 6-Q. The deceleration lane following the intersection has no access permitted in accordance with the prior paragraph.

Where access is proposed at new or existing jughandle locations, design waivers (submitted as an attachment to the permit application) to the above paragraph will be granted only after a thorough analysis has been made with respect to the cost of acquisition and impact on safety. For further information on access control, see Section 5.8, "Driveways".

The designer should also reference the *NJ State Highway Management Code* for further information.

6.8.4 Standard Jughandle Designs

Figures 6-O through 6-Q illustrate the basic jughandle configurations. The dimensions and radii shown are recommended, however, social, environmental or economic impacts may make adherence to the basic geometrics impractical. The recommended design speeds for the basic jughandle configurations are shown in Table 6-2.

Pedestrian and bicycle accommodations should be added at all proposed jughandles and should be added at existing jughandles whenever feasible.

Table 6-2
Jughandle Design Speeds

Jughandle Type	Minimum Design Speed (mph)
A	25
B - one lane	15
B - one lane with T Intersection	20
B - two lane	25
C - loop ramp	15 (20 des.)
C - finger ramp	25

When initially providing jughandles at locations where there are no existing cross streets or there is an intersecting street on only one side, the designer should evaluate the future development potential of the property adjacent to the jughandle. Consideration should be given to designing the jughandle for future expansion to accommodate the access needs of the adjacent property.

The design of Type "B" jughandles should generally be limited to locations where the development of the adjacent land is limited due to topography, environmental constraints, zoning restrictions, etc.

6.8.5 Superelevation and Cross Slope

It is desirable to provide as much superelevation as practical on jughandles, particularly where the ramp curve is sharp and on a downgrade. Table 6-3 provides a suggested range of superelevation rates in percent for various ramp radii. Rates in the upper half or third of the indicated range are preferred. The cross slope on tangent sections of ramps are normally sloped one-way at 2 percent, which is considered a practical minimum for effective drainage across the surface (see Figure 5-J).

Table 6-3
Jughandle (Ramp) Superelevation (%)

Design Speed mph	Radius (feet)					
	50	90	150	230	310	430
	Superelevation (%)					
15	2-6	2-6	2-5	2-4	2-3	2-3
20	---	2-6	2-6	2-6	2-4	2-3
25	---	---	4-6	3-6	3-6	3-5
30	---	---	---	6	5-6	4-6

Exceptions to the use of full superelevation are at street intersections where a stop or yield condition is in effect.

The length of superelevation transition should be based on Section 4.3.2.B. With respect to the beginning and ending of a curve on the ramp proper (not including terminals), see Table 4-4 for the portion of the runoff located prior to the curve. This may be altered as required to adjust for flat spots or unsightly sags and humps when alignment is tight. The principal criteria is the development of a smooth-edge profile that does not appear distorted to the driver.

See Section 7.7.2, "Ramp Terminals," for a discussion on development of superelevation at free-flow ramp terminals and the maximum algebraic difference in cross slope at crossover line.

6.8.6 Crosswalks, Pavement Markings and Bike Lanes

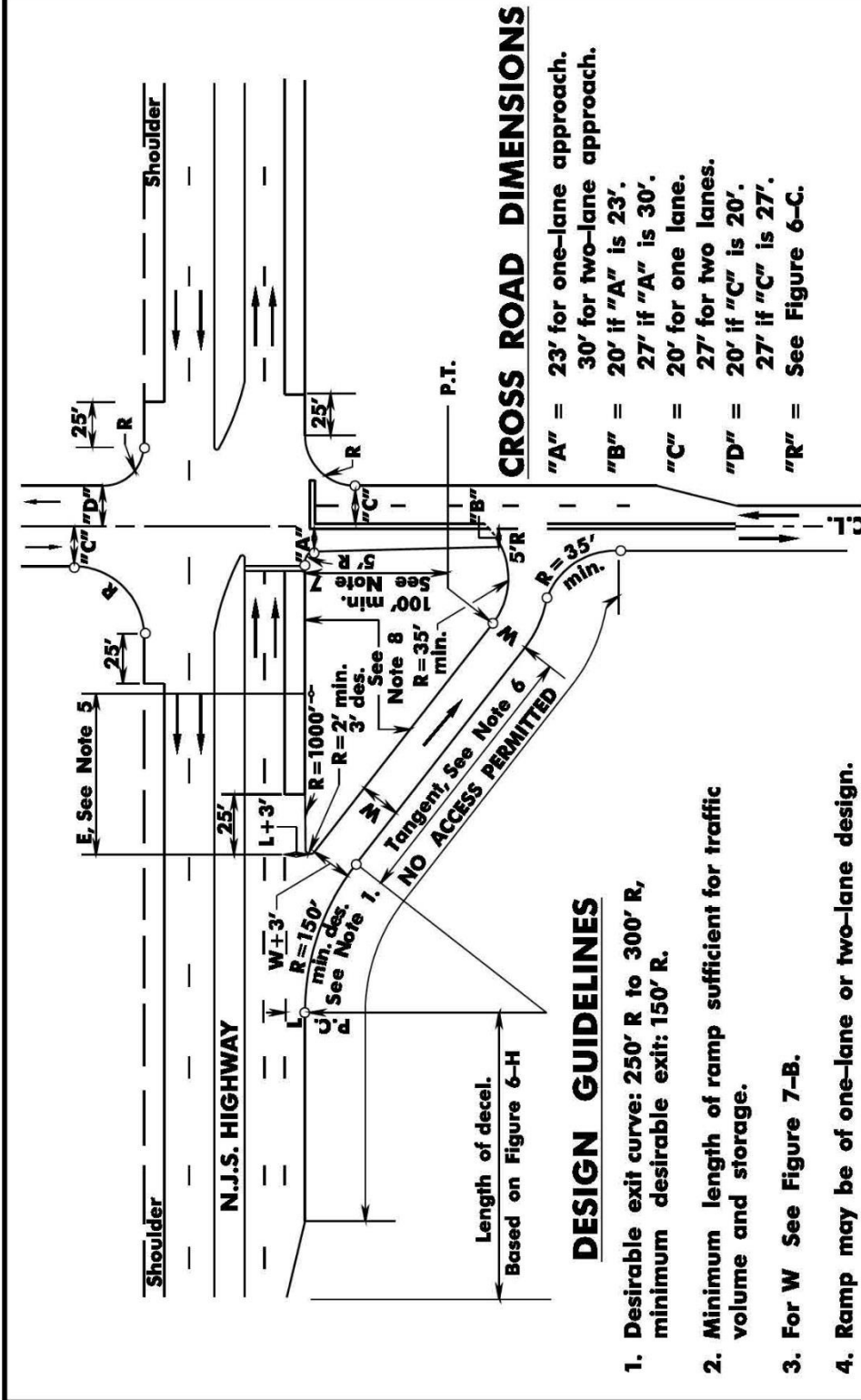
Where pedestrian volumes warrant, crosswalk pavement should be placed at the desired crossing location. Supplemental warning signs and lighting may be provided.

Bike lanes may continue through the jughandle if cyclists can be expected to use the jughandle to make a turn (for example, to connect to another bike lane).

Crosswalks, pavement markings and bike lanes should be designed as per the MUTCD.

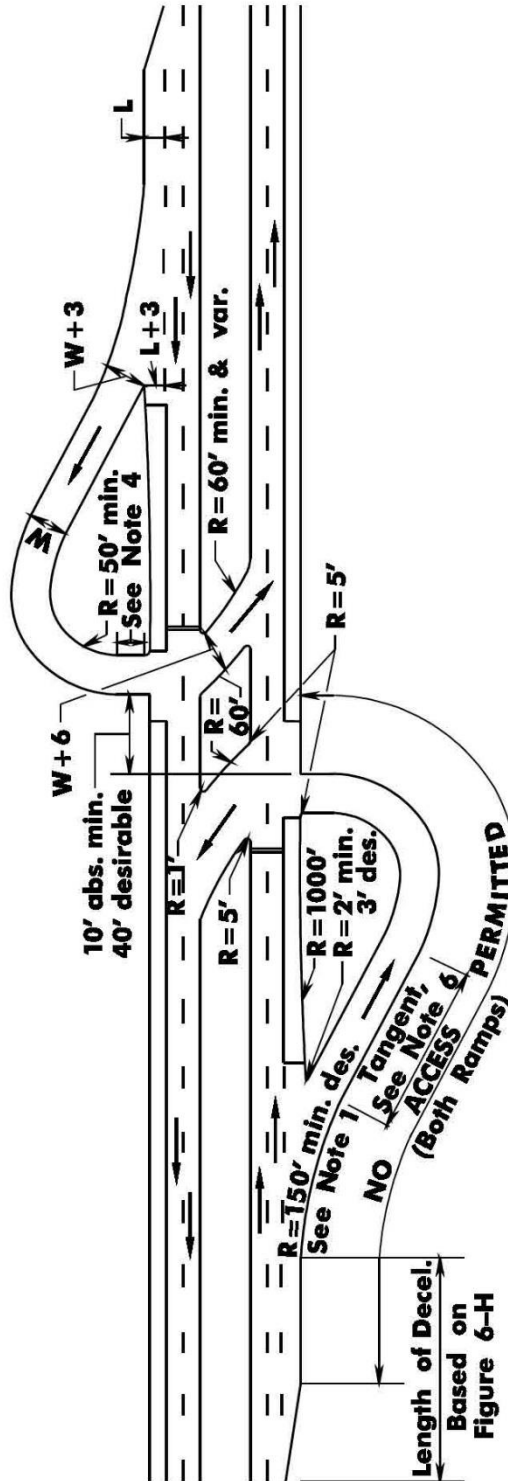
When crosswalk striping is deemed necessary, design traffic signal and stop sign controlled intersections using standard parallel lines - 6 feet apart. The enhanced diagonal or longitudinal crosshatching is reserved for more atypical, unexpected pedestrian crossing locations, as per MUTCD Section 3B.17.

**FIGURE 6-O:
TYPICAL TYPE "A" JUGHANDLE**



REV. DATE: JUNE 30, 2015

**FIGURE 6-P:
TYPICAL TYPE "B" JUGHANDLE**



DESIGN GUIDELINES

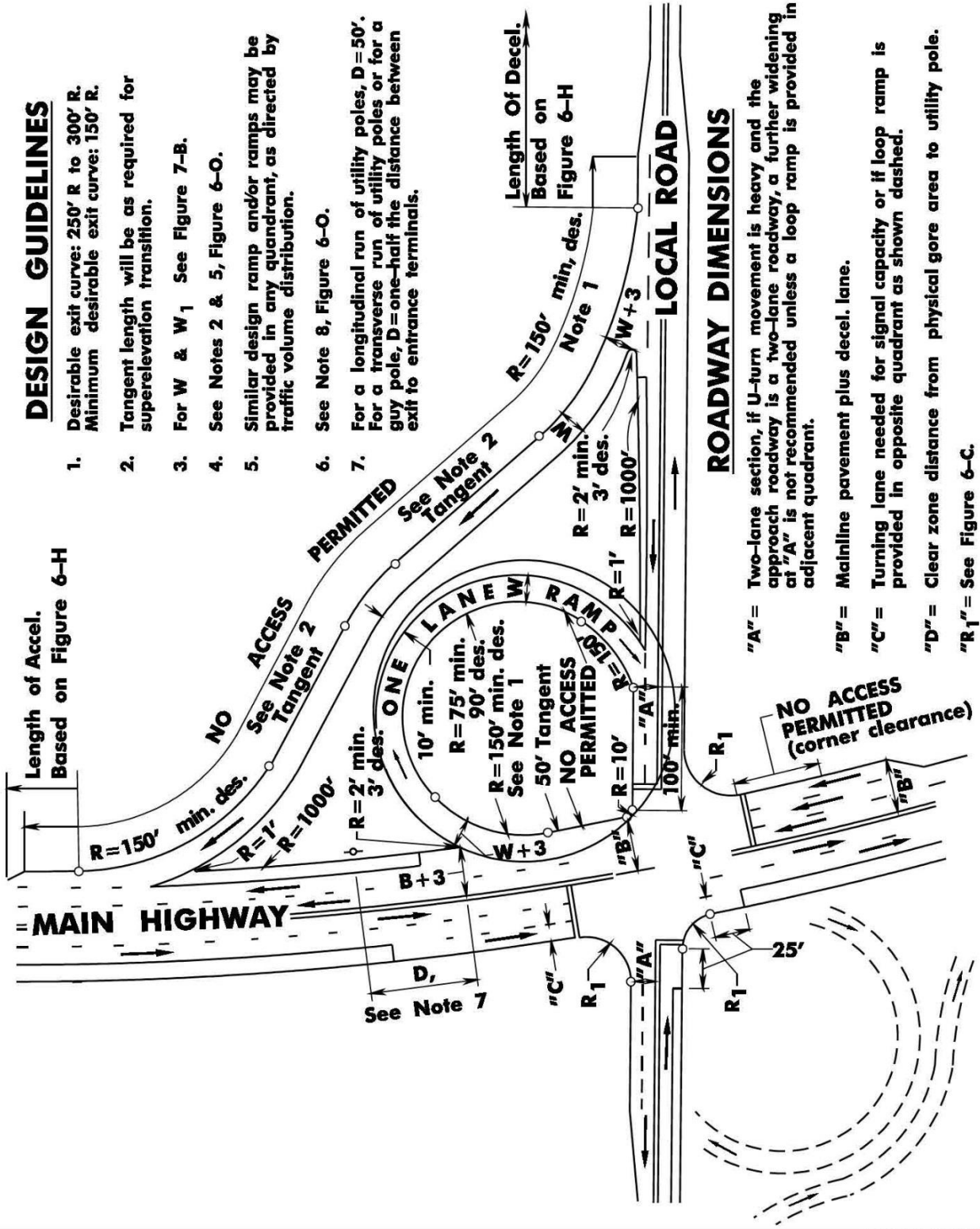
1. Desirable exit curve: 250' R to 300' R, minimum desirable exit curve: 150' R.
2. Minimum length of ramp sufficient for traffic volume and storage.
3. See Note 5, Figure 6-N.
4. Tangent distance: 25' absolute minimum, 100' desirable.
5. Ramp may be of one-lane or two-lane design.
6. Tangent length will be as required for superelevation transition.
7. For W, See Figure 7-B.
8. The 50' minimum radius is for low volume one-lane U-turns. Where the jughandle is used to provide one-lane access to a T-intersection, it should have a minimum radius of 90'. If a two-lane jughandle is to be provided, a 150' minimum radius shall be used.
9. Infield areas may be used as retention or detention basins, but the design water surface elevation should be located outside the clear zone.

REV. DATE: JUNE 30, 2015

**FIGURE 6-Q:
TYPICAL TYPE "C" JUGHANDLE**

DESIGN GUIDELINES

1. Desirable exit curve: 250' R to 300' R.
Minimum desirable exit curve: 150' R.
2. Tangent length will be as required for superelevation transition.
3. For W & W₁ See Figure 7-B.
4. See Notes 2 & 5, Figure 6-O.
5. Similar design ramp and/or ramps may be provided in any quadrant, as directed by traffic volume distribution.
6. See Note 8, Figure 6-O.
7. For a longitudinal run of utility poles, D = 50'. For a transverse run of utility poles or for a guy pole, D = one-half the distance between exit to entrance terminals.



ROADWAY DIMENSIONS

- "A" = Two-lane section, if U-turn movement is heavy and the approach roadway is a two-lane roadway, a further widening at "A" is not recommended unless a loop ramp is provided in adjacent quadrant.
- "B" = Mainline pavement plus decel. lane.
- "C" = Turning lane needed for signal capacity or if loop ramp is provided in opposite quadrant as shown dashed.
- "D" = Clear zone distance from physical gore area to utility pole.
- "R₁" = See Figure 6-C.

REV. DATE: JUNE 30, 2016

6.9 Other Considerations

6.9.1 Parking Restrictions at Intersections

Vehicular parking should not be permitted within the immediate limits of at-grade intersections; see Section 6.3, "Sight Distance," for sight distance requirements at intersections.

6.9.2 Lighting at Intersections

Lighting affects the safety of highway and street intersections and the ease and comfort of traffic operations. In urban and suburban areas where there are concentrations of pedestrians and roadside and intersection interferences, fixed-source lighting tends to reduce accidents. Whether or not rural at-grade intersections should be lighted depends on the planned geometrics and the turning traffic volumes involved. Intersections that generally do not require channelization are seldom lighted. However, for the benefit of non-local highway users, lighting at rural intersections is desirable to aid the driver in ascertaining sign messages during non-daylight period.

Intersections with channelization, particularly with multiple-road geometrics, should include lighting. Large channelized intersections especially need illumination because of the higher range of turning radii that are not within the lateral range of vehicular headlight beams. Vehicles approaching the intersection also must reduce speed. The indication of this need should be definite and visible at a distance from the intersection that may be beyond the range of headlights. Illumination of at-grade intersections with fixed-source lighting accomplishes this need.

See Section 11, "Highway Lighting Systems," for guidelines in the planning and design of roadway lighting systems.

6.10 Bus Turnouts

6.10.1 Introduction

To reduce conflicts on state highways between through traffic and buses stopped to receive and/or discharge passengers, bus turnouts may be provided on land service highways when the outside shoulders on the highway are less than 10 feet in width. Bus turnouts should be designed to accommodate adjacent pedestrian walking space. The designer shall in conjunction with the transit agency providing service along the highway determine the locations of the bus turnouts.

Bus turnouts are most appropriate along roadways with:

- Vehicle speeds greater than 40 mph
- Moderate to high vehicle volumes
- Bus layover locations
- Wheelchair boarding areas

See Section 5 for further information on pedestrian accommodations at transit stops.

6.10.2 Location Criteria

When it has been determined that bus turnouts are appropriate, the following criteria should be used to select the bus turnout location(s):

1. The location should principally facilitate pedestrian access to the bus and transfers between transit lines. For example, if a housing development is located on one corner of an intersection, the bus stop/pullout should be located on that corner, regardless of whether it is a near or far-side turnout. Where two bus lines cross then the stops should be located so that riders have to cross the fewest number of streets to transfer. Note that transfers may be heavier in one direction (peak) than the others
2. The location should be close to the points of origins and/or destinations of the transit rider. Locations convenient to park and ride facilities, intermodal transfer facilities and transfer facilities between bus service are desirable.
3. The bus turnouts should be located where patrons may park and cross roadways legally and safely. Desirably bus turnouts should be located within 400 feet of an intersection or parking areas used by the bus patrons. Alternatives including review and possible modification of parking regulations may be considered.
4. Access to and from the bus stop is convenient to well-lit pedestrian crossings, crosswalks or signalized crosswalks.
5. Desirably there should not be any driveways within the bus turnout. As a minimum, there shall be no driveways located within the bus stopping area. Driveways may be located within the acceleration and deceleration portion of the bus turnout including the taper. However, to minimize conflicts between the vehicles using the driveway and the bus, the bus stopping area should desirably be located on the far side of the driveway.
6. The vertical and horizontal highway geometry meets current stopping sight distance criteria.
7. There is sufficient right-of-way available, or its acquisition would not involve developed parcels or environmentally sensitive parcels.
8. A bus turnout may be placed on the far side or near side of an intersection, or at mid-block. When placed at intersections, locating the bus turnout on the far side is preferred. Near side bus turnouts create conflict with right turning traffic, obscure pedestrian view of oncoming traffic and may obscure a driver's view of signs, traffic control devices and pedestrians. Mid-block turnouts may be provided when there is a need to service a major pedestrian traffic generator (i.e., shopping mall, school railroad station, hospital, etc.).
9. The location of the bus turnouts conform to local ordinances.

6.10.3 Other Considerations

In addition to the location criteria noted in Section 6.10.2, the following features should be considered when selecting bus turnout locations:

1. Utility and signal poles - The relocation of utility poles could require the acquisition of additional right-of-way, and depending upon the type of service provided involve excessive relocation costs. The location of the bus turnouts at intersections could involve costly signal relocations and when placed on the near side of the intersection stopped buses could obscure the signals.
2. Drainage - To avoid splashing of bus riders turnouts should not be located at low points in the vertical alignment. Also, additional inlets may be necessary to limit

the spread in the gutter to 3 feet Grades should be checked to avoid ponding where pavement cross slope exceeds the longitudinal slope in the turnout.

3. Guide rail - Openings in guide rail located along the curblines may not be permitted due to inadequate length of need or the inability to provide the proper end treatment.
4. Signing - The location of the bus turnout could interfere with the visibility of regulatory, warning and/or directional signs. The relocation of existing signs and/or the installation of new signs including bus stop signs shall be coordinated with the Bureau of Traffic Signals and Safety.
5. Handicapped ramps - When the construction of a bus turnout impacts an existing handicapped ramp(s) at an intersection, the designer shall assess the entire intersection to determine if the remaining curb ramps will be compatible. (see section 5.7.4)
6. Curb - Curb shall be provided at all bus turnouts. The curb height shall conform to Section 5.6.
7. The pavement section for widening or reconstruction of shoulders for bus turnouts should be determined by Geotechnical Engineering.

6.10.4 Bus Turnout Design Criteria

Figure 6-R illustrates typical bus turnout designs for a far side and an alternate far side bus turnout. Figure 6-S illustrates a typical mid-block turnout.

The bus stopping areas shall be a minimum of 50 feet in length for each standard 40 foot bus and 70 feet for every 60 feet bus expected to use the bus turnout. When more than one bus is expected to use the turnout simultaneously, the length of the bus stopping area should be adjusted accordingly. Desirably the width of the bus stopping area including the acceleration and deceleration lanes should be 12 feet where it is not practical to provide the 12 feet width, a minimum width of 10 feet may be provided to reduce right-of-way or environmental impacts.

Bus turnouts generally consist of entrance and exit tapers, deceleration and acceleration lanes, and a bus stopping area. The length of the tapers and the deceleration and acceleration lanes vary depending on the posted speed of the highway. Table 6-4 provides the desirable lengths. The use of lengths less than those shown in Table 6-4 may cause delays to the transit service and adversely impact the traffic flow on the highway.

Table 6-4

Posted Speed (mph)	Length of Acceleration Lane (feet)	Length of Deceleration Lane (feet)	Length of Entrance and Exit Tapers (feet)
35	250	185	170
40	400	265	190
45	700	360	210
50	975	470	230
55	1400	595	250

Source: TCRP Report 19, Guidelines for the Location and Design of Bus Stops

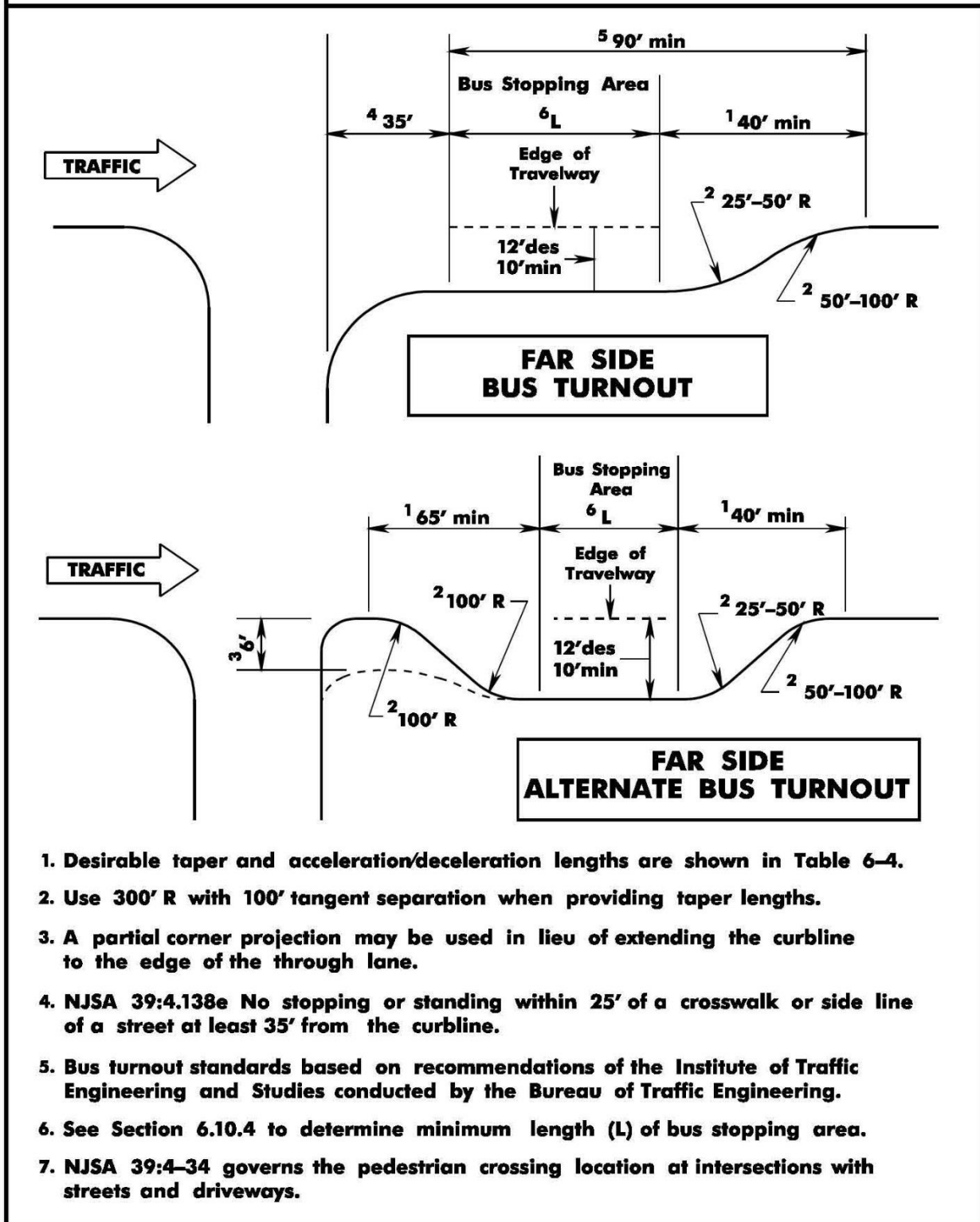
As a minimum bus turnouts may be constructed without acceleration and deceleration lanes when it is not practical to provide the above lengths. However, the designer should attempt to provide as much acceleration and deceleration lane length as practical.

The taper lengths shown in the Table are desirable. Minimum entrance and exit tapers shown in Figure 6-R and 6-S may be provided when it is not practical to provide those shown in the Table. The minimum lengths of taper are applicable with or without acceleration or deceleration lanes.

The pavement cross slope in the bus turnout shall be one half ($\frac{1}{2}$) percent greater than the adjacent through lane. On superelevated roadway sections, the pavement cross slope shall be the same as the adjacent through lane. When conditions dictate maintaining drainage flow in the existing gutter, the bus turnout may be sloped toward the gutter line at 1.5 to 2.0 percent.

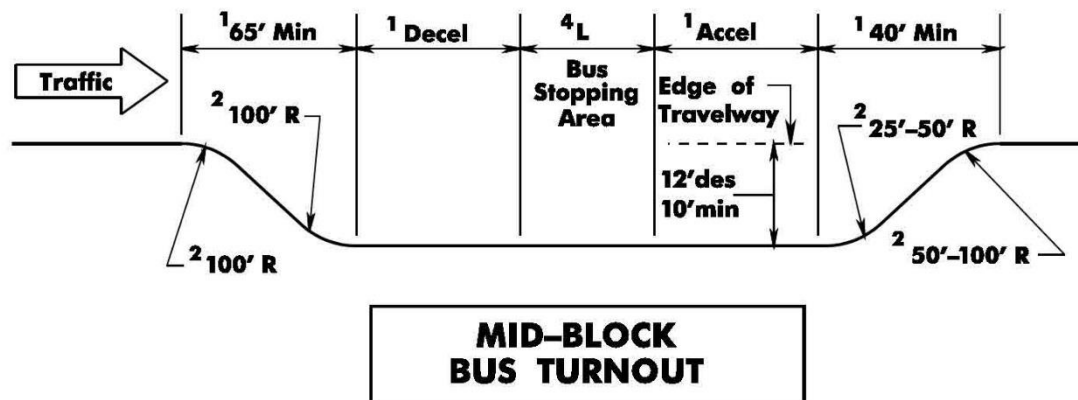
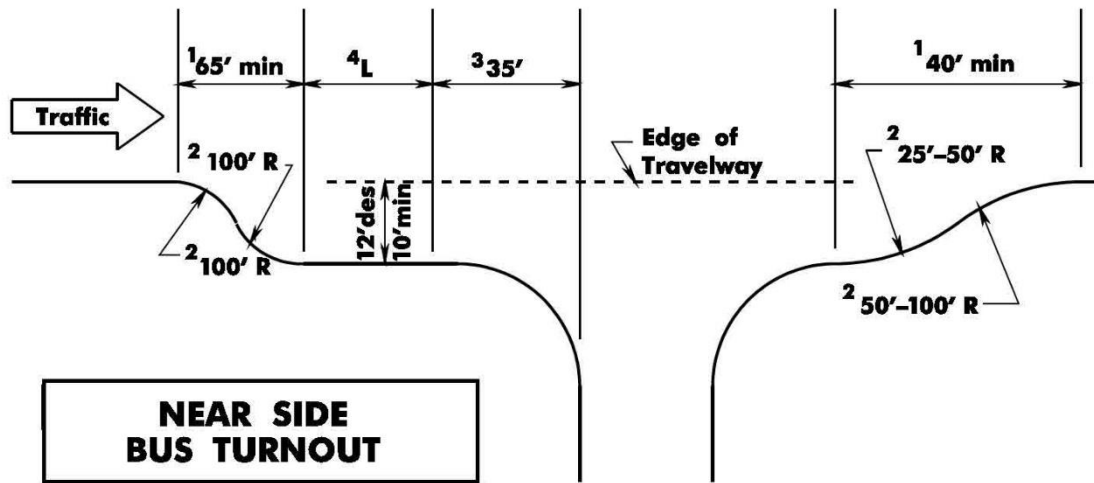
The width of the sidewalk in the bus loading area should be sized to provide a level of service for waiting passengers and other pedestrian traffic with a minimum width of 7 feet. See Section 5. Sidewalk should be provided where there is no existing sidewalk approaching the bus loading area.

**FIGURE 6-R:
TYPICAL BUS TURNOUTS**



REV. DATE: JUNE 30, 2015

**FIGURE 6-5:
TYPICAL BUS TURNOUTS**



1. Desirable taper and acceleration/deceleration lengths are shown in Table 6-4
2. Use 300' with 100' tangent separation when providing taper lengths
3. NJSA 39:4.138e No stopping or standing within 25' of a crosswalk or side line of a street at least 35' from the curbline
4. See Section 6.10.4 to determine minimum length (L) of bus stopping area
5. NJSA 39:4-34 governs the pedestrian crossing location at intersections with streets and driveways

REV. DATE: JUNE 30, 2016

Section 7 - Interchanges

7.1 General

The capacity of arterial highways, particularly in urban areas, to handle high volumes of traffic safely and efficiently depends, to a considerable extent, upon their ability to accommodate crossing and turning movements at intersecting highways. The greatest efficiency, safety and capacity are attained when the intersecting through traffic lanes are grade separated.

An interchange is a system of interconnecting roadways in conjunction with one or more grade separations, providing for the movement of traffic between two or more roadways on different levels. Safety and traffic capacity are increased by the provision of interchanges. Crossing conflicts are eliminated by grade separations. Turning conflicts are either eliminated or minimized, depending upon the type of interchange design.

One intent of this section is that except in the most extreme circumstances, all new interchanges should provide for all movements. However, it is recognized that circumstances may exist when initial construction of only part of an interchange might be appropriate. Where such circumstances exist, commitments must be made, possibly even purchase of necessary right-of-way during the initial project stage for future completion.

7.2 Warrants for Interchanges

7.2.1 Freeways and Interstate Highways

Interchanges should be provided on Interstate highways and freeways at all intersections where access is to be permitted. Other intersecting roads or streets are either grade separated, terminated, or rerouted.

7.2.2 Other Highways

On highways with only partial control or no control of access, definite warrants cannot be specified as they may differ at each location. The following factors should be considered in analyzing a particular situation:

1. Design Designation

The determination to develop a highway with full control of access between selected terminals becomes the warrant for providing a highway grade separation. Once the decision is made to develop a route as a freeway, it should be determined whether each intersection highway will be terminated, rerouted, or provided with a grade separation or interchange. The major concern is the continuous flow on the major road. An intersection that might warrant only traffic signal control, if considered as an isolated case, will warrant a grade separation or interchange when considered as a part of a freeway.

2. Reduction of Congestion

Insufficient capacity at the intersection of heavily traveled highways results in intolerable delays and congestion in one or all approaches. The inability to provide the essential capacity with an intersection at grade provides the warrant for an interchange.

3. Improvement of Safety

Some intersections at grade have a high accident rate even though serving light traffic volumes. Other more heavily traveled intersections have a history of serious accidents. If the safety at such intersections cannot be improved by more inexpensive methods, construction of an interchange facility may be warranted.

4. Site Topography

At some sites, the topographic conditions may be such that the provisions of an interchange facility may entail no more cost than an at-grade intersection.

5. Traffic Volume

For a new intersection under design, an interchange would be warranted where a capacity analysis indicates that an at-grade design cannot satisfactorily serve, without undue delay and congestion, the traffic volumes and turning movements expected.

6. Road-user Benefits

Road-user costs include fuel and oil usage, wear on tires, repairs, delay to motorists and crashes as a result of speed changes, stops and waiting. Road user costs at congested at-grade intersections are well in excess of those for intersections permitting uninterrupted or continuous operation. Interchanges may involve more total travel distance than at grade crossings, but the added cost of the extra travel distance is less than the cost savings resulting from the reduction in stopping and delay. The relation of road-user benefits to the cost of improvement indicates an economic warrant for that improvement.

7.3 Interchange Types

7.3.1 General

The selection of an interchange type and its design are influenced by many factors, including the following: the highway classification, design speed, volume and composition of traffic to be served, the number of intersecting legs, the standards and arrangement of the local street system including traffic control devices, topography, right-of-way controls, local planning, proximity of adjacent interchanges, community and environmental impact consideration and cost. Even though interchanges are, of necessity, designed to fit specific conditions and controls, it is desirable that the pattern of interchange ramps along a freeway follow some degree of consistency. It is frequently desirable to rearrange portions of the local street system in connection with freeway construction in order to effectuate the most desirable overall plan of traffic service and community development.

The use of isolated ramps or partial interchanges should be avoided because wrong-way movements are more prevalent at isolated off-ramps and there is less confusion to motorists where all traffic movements are provided at an interchange. In general, interchanges with all ramps connecting with a single cross street are preferred.

Interchange types are characterized by the basic shapes of ramps: namely; diamond, loop, directional or variations of these types. Many interchange designs are combinations of these basis types.

7.4 Interchange Design Elements

7.4.1 General

Geometric design for all interchange roadways should follow the design guides as covered in Section 4, "Basic Geometric Design Elements."

7.4.2 Spacing

The minimum spacing of interchanges for proper signing on the main road should be at least 1 mile between urban crossroads and 2 miles along rural sections. In urban areas, spacing of less than 1 mile may be developed by using grade separated ramps or by adding collector-distributor roads. Closely spaced interchanges interfere with free traffic flow and safety, even with the addition of extra lanes, because of insufficient distance for weaving maneuvers. During the early design stage, the Bureau of Traffic Signals and Safety Engineering should be consulted to assure that proper signing of the interchange is possible.

7.4.3 Sight Distance

Sight distance along the through roadways and all ramps should be at least equal to the minimum safe stopping sight distance and preferably longer for the applicable design speed. See Sections 4 & 6 for sight distance requirements.

7.4.4 Alignment, Profile and Cross Section

Traffic passing through an interchange should be provided the same degree of utility and safety as on the approaching highways. The standards for design speed, alignment, profile and cross section for the main lanes through the interchange area should be as high as on the approach legs. Desirably, the alignment and profile of the through highways at an interchange should be relatively flat with high visibility. The full roadway cross section should be continued through the interchange area and adequate clearances provided at structures.

7.5 Ramps

7.5.1 General

The term "ramp" includes all types, arrangements, and sizes of turning roadways that connect two or more legs at an interchange. The components of a ramp are a terminal at each end and a connecting road, usually with some curvature, and on a grade. Ramps are one way roadways.

7.5.2 Ramp Capacity

The capacity of a ramp is generally controlled by one of its terminals. Occasionally the ramp proper determines the capacity, particularly where speeds may be significantly affected by curvature, grades, and truck operations. Figure 7-A shows the basic values (Service Volumes) for the ramp proper on single lane ramps.

7.5.3 Design Speed

It is not practical to provide design speeds on ramps that are comparable to those on the through roadways. Ramp design speeds however should not be less than 25 mph. On cloverleaf interchanges, the outer connections should desirably be designed for 35 mph.

Recommended ramp design speeds for various ramp configurations are as follows: Loop ramps, 25 mph; semidirect, 30 mph; and direct connections, 40 mph.

7.5.4 Grades (Profile)

Ramp grades should be as flat as feasible to minimize driving effort required in maneuvering from one road to another. On one-way ramps, a distinction can and should be made between upgrades and downgrades. As general criteria, it is desirable that maximum upgrades on ramps be limited to the following:

**Table 7-1
Upgrades on Ramps**

Design Speed (mph)	Maximum Upgrade Range (Percent)
45 – 50	3 - 5
35 – 40	4 - 6
25 – 30	5 - 7
15 – 25	6 - 8

Minimum ramp grades should not be less than 0.3 percent. One way downgrades on ramps should be held to the same general maximums, but in special cases they may be 2 percent greater. When the ramp is to be used predominately by truck traffic (many heavy trucks), one-way upgrades should be limited to 5 percent. One-way downgrades should be limited to 3-4 percent on ramps with sharp horizontal curves and for heavy truck or bus traffic.

7.5.5 Sight Distance

On ramps, no planting of vegetation that would restrict the sight distance to less than the minimum for the applicable design speed shall be permitted.

7.5.6 Widths

Figure 7-B illustrates the desired ramp widths for various ramp curvatures. Single lane ramp widths will be based on Case II for the ramp proper and Case I at the entrance terminal. Case III should be used in determining ramp widths on two lane ramps. See Section 5, Figure 5-J for typical single and two lane ramp sections.

7.5.7 Location of Ramp Intersection on Cross Road

Factors which influence the location of ramp intersections on the cross road include sight distance, construction and right-of-way costs, circuitry for left turn movements, cross road gradient at ramp intersections, storage requirements for left turn movements off the cross road, and the proximity of other local road intersections.

For left maneuvers from an off ramp at an unsignalized intersection, the length of cross road open to view should be greater than the product of the design speed of vehicles on the cross road and the time required for a stopped vehicle on the ramp to safely execute a left turn maneuver. See Section 6 for sight distance at intersections.

Where design controls prevent locating the ramp terminal a sufficient distance from the structure to achieve the required sight distance, the sight distance should be obtained by flaring the end of the overcrossing structures or setting back the piers or end slopes of an undercrossing structure.

Sharp curves at an off ramp terminal (at the intersection with the local street) should be avoided, even if such an intent is to provide an acceleration lane for merging into the local street traffic. It is often better to provide a near 90 degree intersection with stop sign control. Slip ramps from the freeway to a local parallel two-way street should also be discouraged because of limited sight distance usually encountered at the merge with the local street traffic.

**FIGURE 7-A:
CAPACITY OF RAMP PROPER**

SINGLE-LANE OPERATION													
DESIGN CONDITION	T % TRUCKS DURING PEAK HOUR	DESIGN SPEED V < 20mph 90' min. R = 125' des.			DESIGN SPEED V = 25mph R = 150'			DESIGN SPEED V = 30-40mph R = 230'-430'			DESIGN SPEED V > 50mph R = 690'		
		RATE OF UPGRADE %			RATE OF UPGRADE %			RATE OF UPGRADE %			RATE OF UPGRADE %		
		0-2	3-4	>5	0-2	3-4	>5	0-2	3-4	>5	0-2	3-4	>5
LEVEL OF SERVICE B	0	800	800	800	1000	1000	1000	1100	1100	1100	1220	1220	1220
	5	760	720	700	950	900	870	1050	1000	950	1140	1090	1040
	10	720	670	610	910	830	770	1000	920	850	1090	1000	920
	20	670	570	500	830	720	620	920	780	690	1000	860	750
	30	610	500	420	770	620	530	850	690	580	920	750	630
LEVEL OF SERVICE C	0	1000	1000	1000	1250	1250	1250	1400	1400	1400	1500	1500	1500
	5	950	900	870	1190	1140	1090	1330	1270	1220	1420	1360	1300
	10	910	830	770	1140	1040	960	1270	1170	1080	1360	1250	1150
	20	830	720	620	1040	890	780	1170	1000	870	1250	1070	940
	30	770	620	530	960	780	660	1080	880	740	1150	940	790

Adapted from FHWA report on
"CAPACITY ANALYSIS FOR DESIGN AND OPERATION OF FREEWAY FACILITIES", 1974

Notes:

- For 2 lane ramps multiply tabular values as follows: 1.7 for 20 mph or less, 1.8 for 25 mph, 1.9 for 30 - 40 mph, 2.0 for 50 mph or more.
- For down grades, use same values as for 0 - 2% upgrade.
- To approximate level of service E, multiply above values by 1.25.
- Minimum ramp radius on interstate highways should not be less than 150 feet.

REV. DATE: JUNE 30, 2016

**FIGURE 7-B:
DESIGN WIDTHS OF PAVEMENT FOR TURNING
ROADWAYS**

R RADIUS ON INNER EDGE OF PAVEMENT, FEET	PAVEMENT WIDTH (W) IN FEET FOR:		
	CASE I ENTRANCE TERMINAL WIDTH	CASE II RAMP PROPER WIDTH 1-LANE, ONE WAY OPERATION	CASE III RAMP PROPER WIDTH 2-LANE, ONE WAY OR TWO WAY OPERATION
50	20	26	—
75	19	24	—
100	18	23	SEE NOTE 4
150	18	22	32
200	18	22	31
300	17	22	30
400	17	22	30
500	17	22	30
TANGENT	17	22	29

- NOTES:**
1. Ramp widths are applicable for ramps with or without curb.
 2. Minimum ramp radii will be used to determine ramp width. Width will be applied through entire ramp except at the ramp terminals.
 3. On 2-lane ramps where shoulders 4 feet or wider are provided, reduce ramp pavement width by 4 feet.
 4. 2-lane operation should not be considered on ramps with radii less than 150 feet.
 5. When percentage of semitrailer vehicles exceeds 10%, increase Case I widths by 1 foot, Case II and Case III widths by 2 feet.

REV. DATE: JUNE 30, 2015

7.6 Superelevation and Cross Slope for Interchange Ramps

Table 7-2 provides a suggested range of superelevation rates for various interchange ramp radii. Desirably, 6% superelevation should be used on all interchange ramps with radii of 430 ft. or less. For interchange ramps with radii greater than 430 ft., the use of the higher rate shown in the Table is preferred. Ramp alignment which precludes the attainment of superelevation without a reasonable transition distance should be avoided.

**Table 7-2
Interchange Ramp Superelevation**

Design Speed (mph)	Radius (feet)								
	150	230	310	430	600	1000	1500	2000	3000
25	4 - 6	3 - 6	3 - 6	3 - 5	2 - 4	2 - 3	2	2	2
30	---	6	5 - 6	4 - 6	3 - 5	3 - 4	2 - 3	2	2
35	---	---	---	6	5 - 6	4 - 5	3 - 4	2 - 3	2
40	---	---	---	---	---	5 - 6	4 - 5	3 - 4	2 - 3

Exceptions to the use of the full superelevation are at street intersections where a stop or reduced speed condition is in effect and, under some conditions, at ramp junctions. Edge of pavement profiles should be drawn at ramp junctions to assure a smooth transition.

The cross slope on tangent sections of ramps are normally sloped one-way at two percent, see Figure 5-J.

The length of superelevation transition should be based on section 4.3.2. With respect to the beginning and ending of a curve on the ramp proper (not including terminals), see Table 4-4 for the portion of the runoff located prior to the curve. This may be altered as required to adjust for flat spots or unsightly sags and humps when alignment is tight. The principal criteria are the development of smooth-edge profiles that do not appear distorted to the driver.

See Section 7.7.2, "Ramp Terminals", for a discussion on development of superelevation at free-flow ramp terminals and the maximum algebraic difference in cross slope at crossover line.

7.7 Freeway Entrances and Exits

7.7.1 Basic Policy

Desirably all interchange entrances and exits should connect at the right of through traffic. Freeway entrances and exits should be located on tangent sections where possible in order to provide maximum sight distance and optimum traffic operation.

7.7.2 Ramp Terminals

The ramp terminal is the portion of the ramp adjacent to the through lanes and includes the speed change lanes, tapers, gore areas, and merging ends. The ramp terminal may also include cross walks, either striped or unmarked, if the ramp enters a land service roadway. For guidance on this subject, refer to the MUTCD. Figures 7-C

through 7-H illustrate the various ramp terminal treatments. The method of developing superelevation at free-flow ramp terminals is shown in Figure 7-H.

Figure 7-H schematic 1 shows a deceleration lane type exit on a tangent section of highway that leads into a flat existing curve. At Point B, the normal crown of the through roadway is projected onto the auxiliary pavement. At Point C, the crown line can be gradually changed to start the development of superelevation for the exiting curve. At Point D, two breaks in the crossover crown line in the painted gore would be conducive to developing a full superelevation in the vicinity of the physical nose.

Figure 7-H schematic 2 shows a deceleration lane type exit on a curved section of highway. The superelevation of the highway would be projected onto the auxiliary pavement.

Figure 7-H schematic 3 shows an acceleration lane type entrance on the high side of a superelevated horizontal curve. At Point D, the ramp superelevation would be close to zero and full superelevation would be attained at Point C.

Figure 7-H schematic 4 shows a typical cloverleaf entrance and exit on a tangent section of highway that leads into sharp curvature developing in advance of the physical nose. Part of the cross slope change can be attained over the length of the parallel auxiliary lane with about half of the total superelevation being attained at Point B. Full superelevation of the ramp proper is reached beyond the physical nose.

Superelevation transition should not exceed a maximum distribution rate of two percent per second of time for the design speed. Also, the suggested maximum differences in cross slope rates at the crossover crown line, related to the speed of turning traffic, should not exceed the values shown in Table 7-3. The design control at the crossover crown line is the algebraic difference in cross slope rates of the ramp terminal pavement and the adjacent mainline pavement. A desirable maximum difference at a crossover line is 4 to 5 percent.

Table 7-3
Maximum Differences in Cross Slope
Rates at the Crossover Crown Line

Design Speed of Exit or Entrance Curve (mph)	Maximum Algebraic Difference in Cross Slope at Crossover Line (Percent)
15 and 20	5 – 8
25 and 30	5 – 6
35 and over	4 – 5

7.7.3 Distance between Successive Exits

At interchanges there are frequently two or more ramp terminals in close proximity along the through lanes. In some interchange designs, ramps split into two separate ramps or combine into one ramp. Guidelines for minimum distances between successive ramp terminals are shown in Figure 7-I.

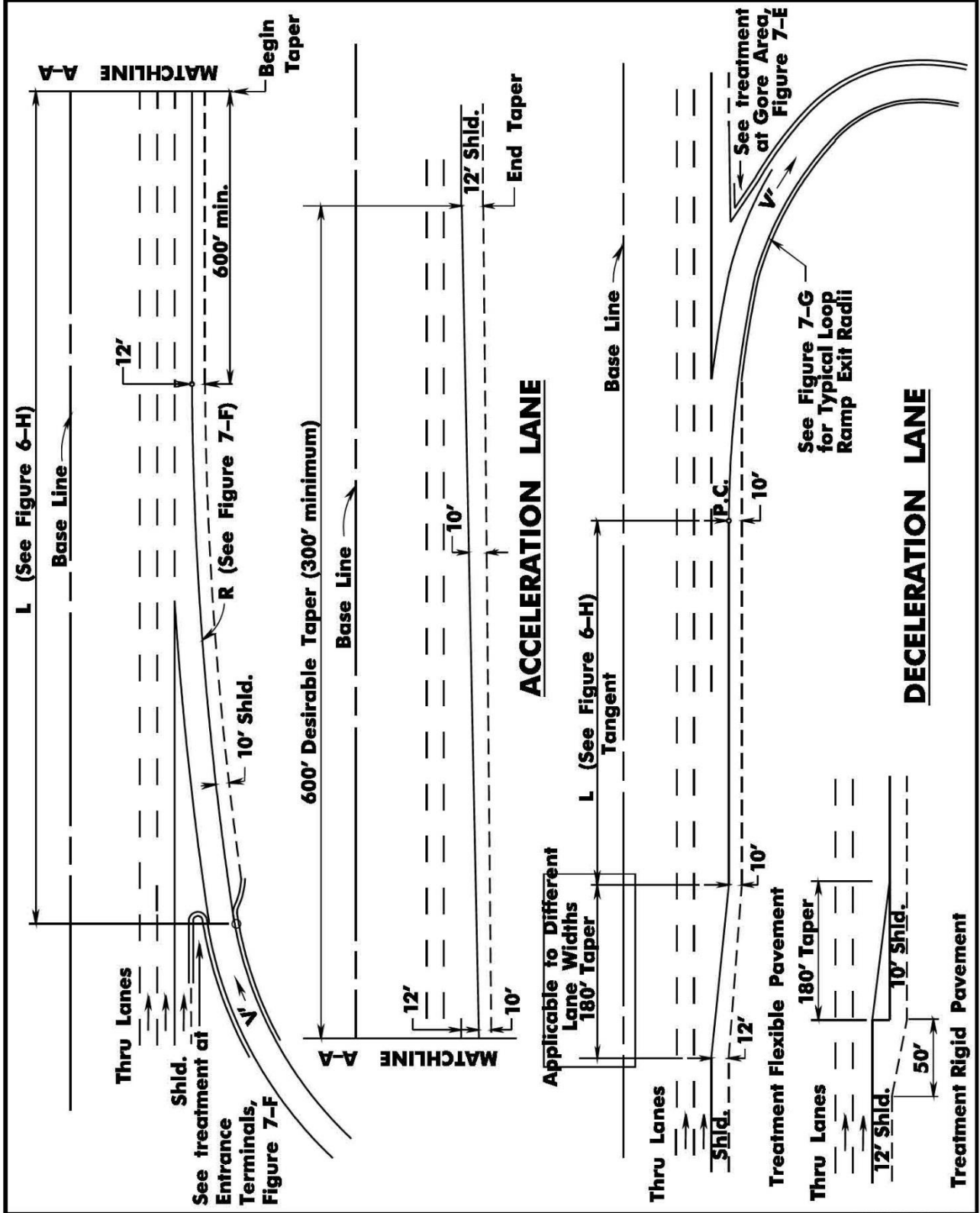
7.7.4 Auxiliary Lane Lengths

The minimum length of acceleration and deceleration lanes on Freeways and Interstate highways are shown in Figures 7-C (with reference to Figure 6-H) and 7-D. The auxiliary lane lengths shown in Figure 6-H are applicable to land service highways. The lengths should be increased when the upgrade exceeds 3 percent on acceleration lanes and on deceleration lanes when the downgrade exceeds 3 percent. The publication *A Policy on Geometric Design of Highways and Streets*, AASHTO, lists the ratio of length of auxiliary lane on grade to length on level.

7.7.5 Curbs

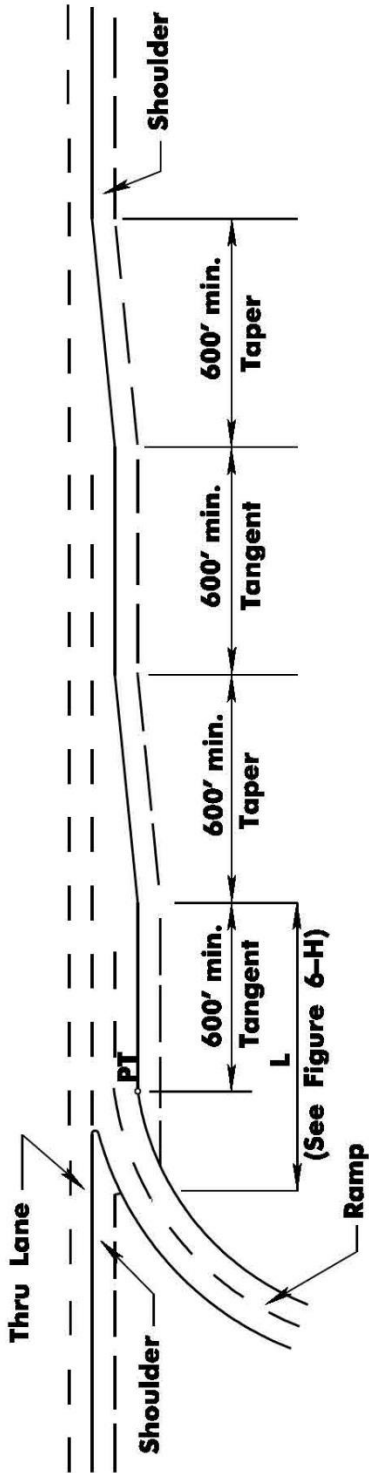
Curbs should not be used on ramps except at the ramp connection with the local street to provide for the protection of pedestrians, for channelization and to provide continuity of construction at the local facility.

**FIGURE 7-C:
INTERSTATE AND FREEWAY RAMP TERMINAL
TREATMENT SINGLE LANE RAMP**

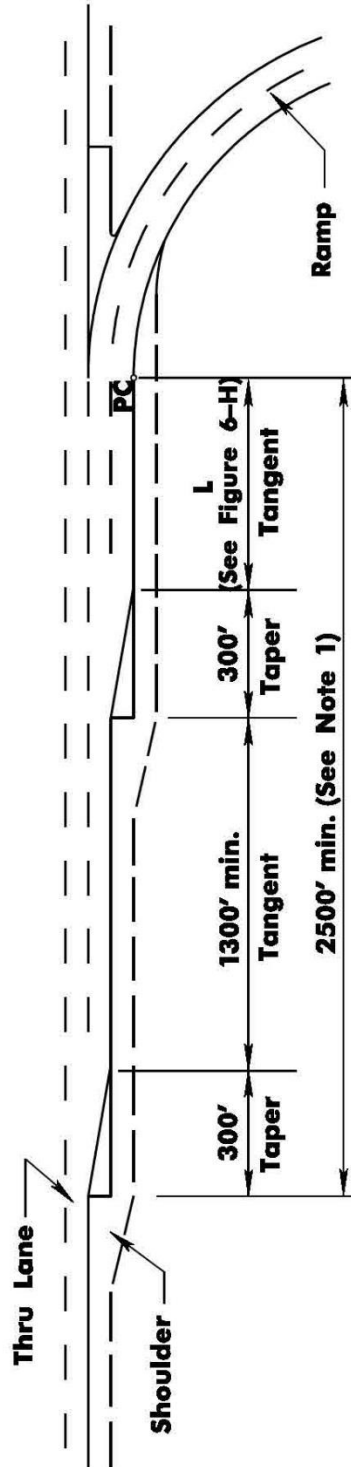


REV. DATE: JUNE 30, 2015

**FIGURE 7-D:
INTERSTATE AND FREEWAY RAMP TERMINAL
TREATMENT MULTI-LANE RAMP**



MULTI-LANE ACCEL.

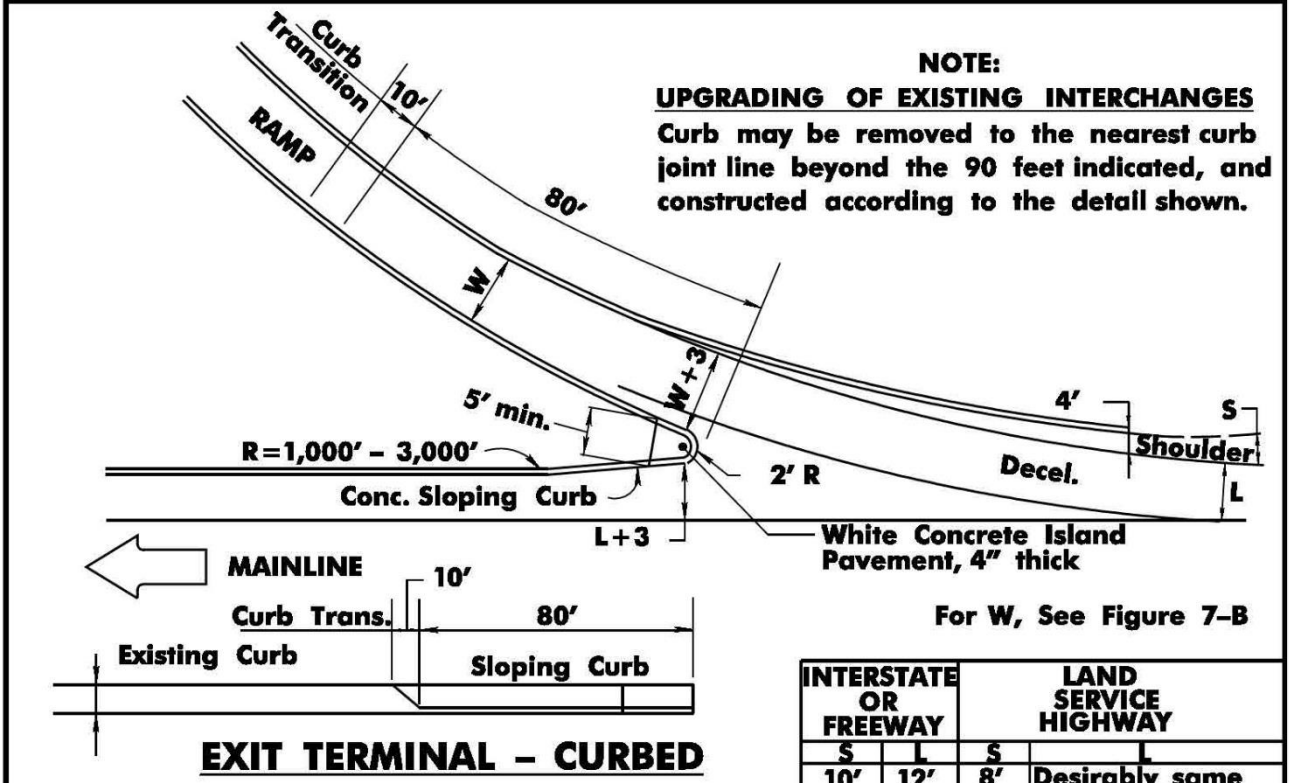


MULTI-LANE DECEL.

Note 1: The total length of the multi-lane decel. will range from 2500 feet for turning volumes of 1500 vph or less upward to 3500 feet for turning volumes of 3000 vph.

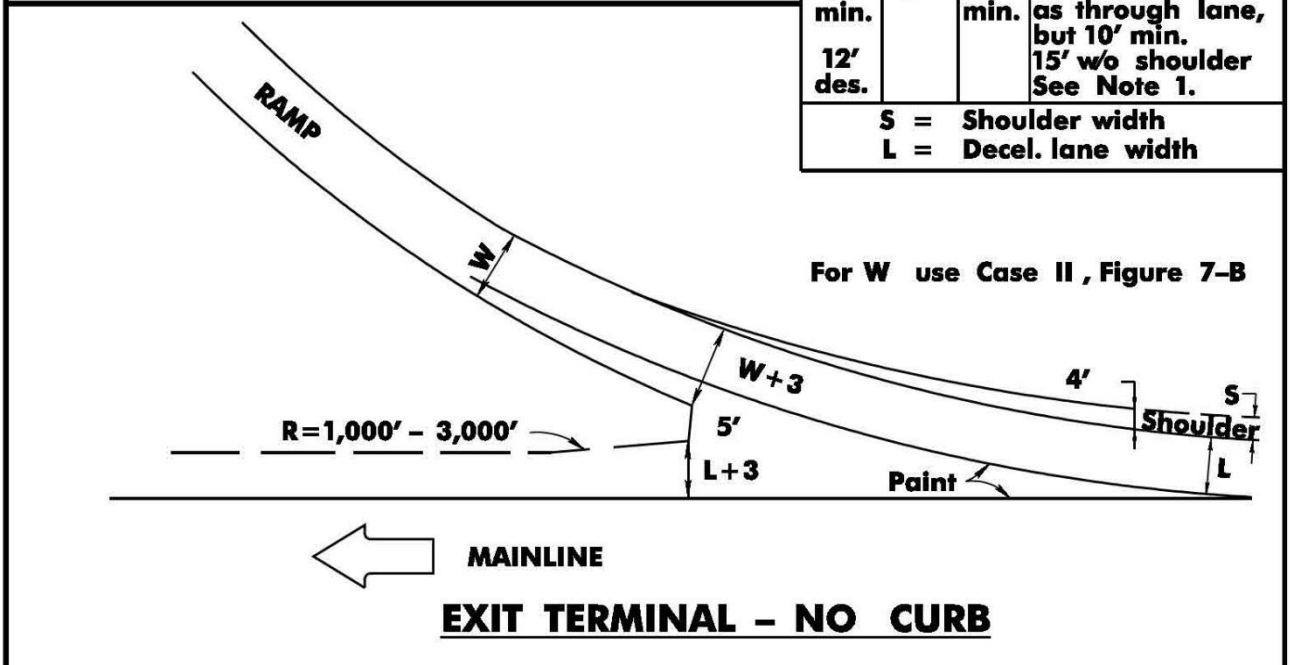
REV. DATE: JUNE 80, 2015

FIGURE 7-E: EXIT TERMINAL TREATMENT



EXIT TERMINAL - CURBED

INTERSTATE OR FREEWAY		LAND SERVICE HIGHWAY	
S	L	S	L
10' min.	12'	8' min.	Desirably same as through lane, but 10' min. 15' w/o shoulder See Note 1.
12' des.			
S = Shoulder width L = Decel. lane width			

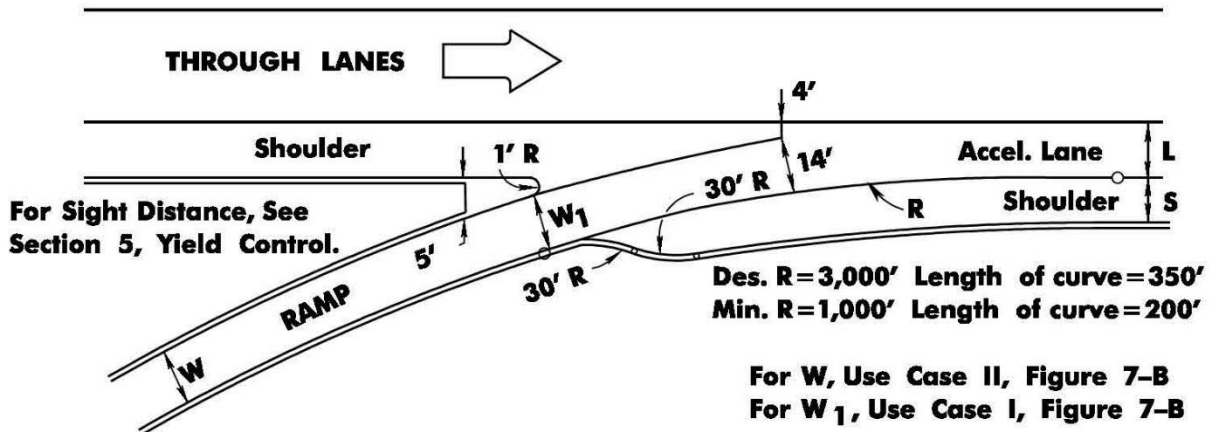


EXIT TERMINAL - NO CURB

Note 1: See Section 5.3 for auxiliary lane width on a land service highway where alternate bike access is provided.

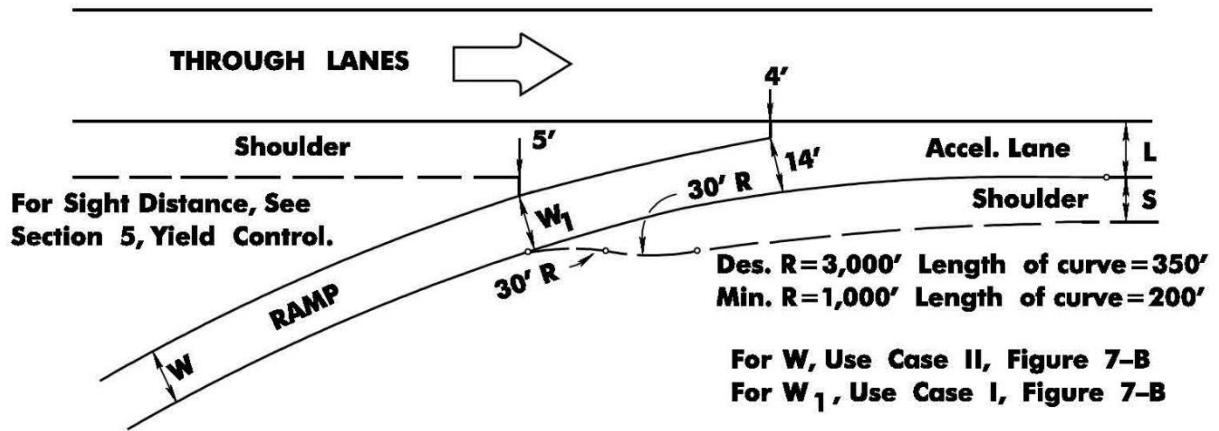
REV. DATE: JUNE 30, 2015

FIGURE 7-F: ENTRANCE TERMINAL TREATMENT



ENTRANCE TERMINAL - CURBED

INTERSTATE OR FREEWAY		LAND SERVICE HIGHWAY	
S	L	S	L
10' min.	12'	8' min.	Desirably same as through lane, but 10' min. 15' w/o shoulder See Note 1.
12' des.			
S = Shoulder Width L = Accel. Lane Width			

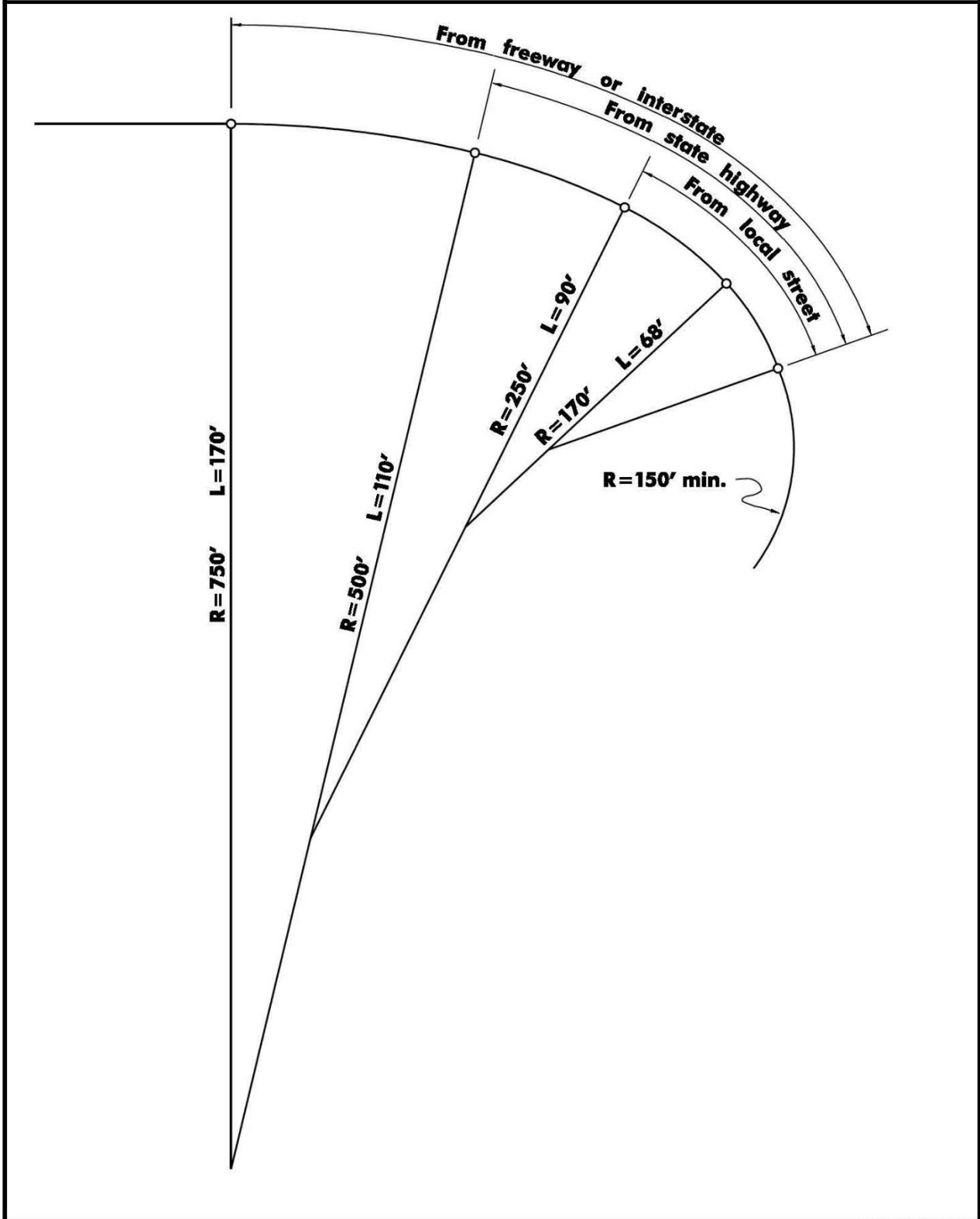


ENTRANCE TERMINAL - NO CURB

Note 1: See Section 5.3 for auxiliary lane width on a land service highway where alternate bike access exists.

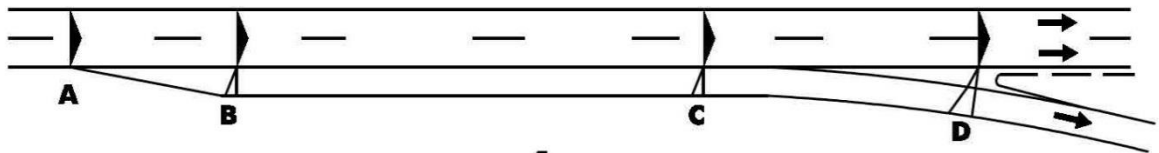
REV. DATE: JUNE 30, 2015

FIGURE 7-G: TYPICAL EXIT RAMP RADII FOR LOOP RAMP



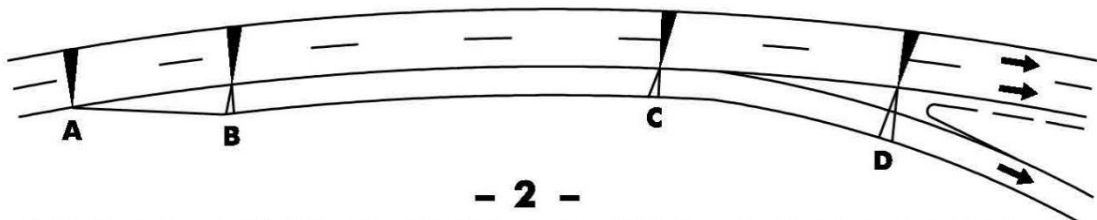
REV. DATE: JUNE 30, 2015

**FIGURE 7-H:
DEVELOPMENT OF SUPERELEVATION AT FREE-FLOW
RAMP TERMINALS**



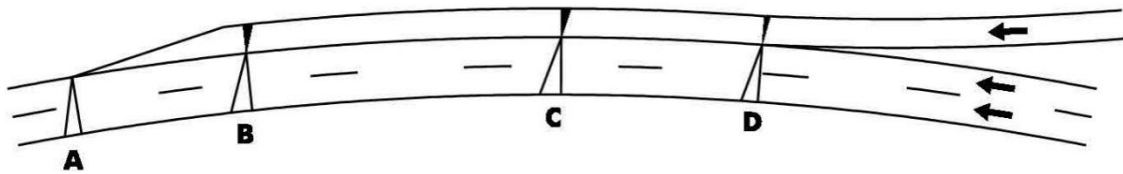
- 1 -

TANGENT DECELERATION LANE TYPE EXIT



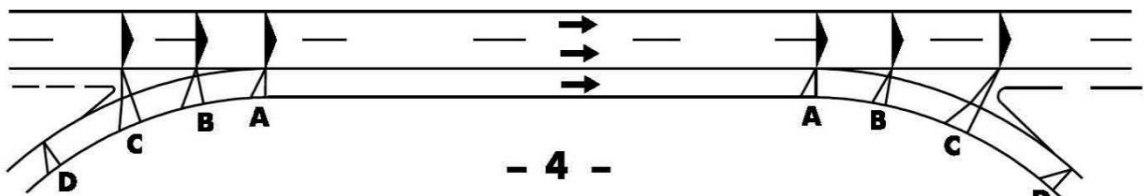
- 2 -

**CURVED SECTION DECELERATION LANE TYPE EXIT
ON LOW SIDE OF SUPERELEVATION**



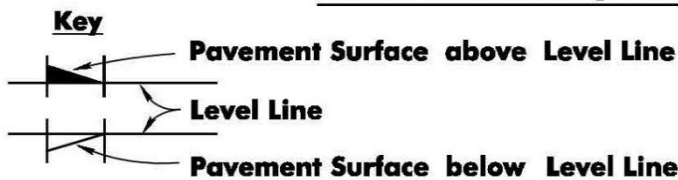
- 3 -

**CURVED SECTION ACCELERATION LANE TYPE ENTRANCE
ON HIGH SIDE OF SUPERELEVATION**



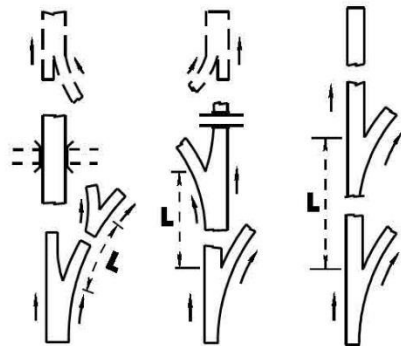
- 4 -

**TANGENT SECTION CLOVERLEAF
TYPE ENTRANCE AND EXIT**

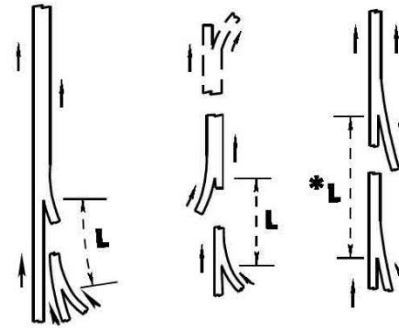


REV. DATE: JUNE 30, 2015

FIGURE 7-1: ARRANGMENTS FOR SUCCESSIVE RAMP TERMINALS



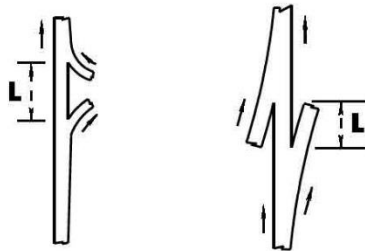
SUCCESSIVE EXIT TERMINALS



SUCCESSIVE ENTRANCE TERMINALS

L = 1000' min. on Freeway or Interstate.

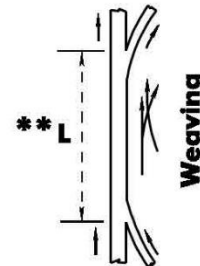
L = 800' min. on C-D Roads and other Arterials.



EXIT TERMINAL FOLLOWED BY ENTRANCE TERMINAL

**L = 500' min. on Freeway
or Interstate.**

**L = 400' min. on C-D Roads
and other Arterials.**



ENTRANCE TERMINAL FOLLOWED BY EXIT TERMINAL

**L = 2,000' min. on Freeway
or Interstate.**

**L = 1,600' min. on Rural
Arterial or Collection.**

**L = 1,000' min. on Urban
Arterial or Collection.**

- * L As noted but not less than length required for Accel. or Decel. Lanes.**
- ** L Length shown is not applicable to distance between Loop Ramps or Cloverleaf interchanges.**

All minimum lengths are measured from physical nose to physical nose. They should be checked in accordance with the procedure outlined in the Highway Capacity Manual and the larger of the values is suggested for use.

Adapted from: A policy on Geometric Design of Highways and Streets, A.A.S.H.T.O.

REV. DATE: JUNE 30, 2015

7.8 Additional Lanes

In order to ensure satisfactory operating conditions, additional lanes may be added to the basic width of traveled way.

Where an entrance ramp of one interchange is closely followed by an exit ramp of another interchange, the acceleration and deceleration lanes may be joined. This should be the general practice where the weaving distance is less than 2000 ft. Where interchanges are more widely spaced and ramp volumes are high, the need for an additional lane between the interchanges should be determined by an across-freeway-lane volume check. An "across-freeway-lane volume check" is a Highway Capacity Methodology not specifically defined. The methodology considers the theoretical capacity of the freeway and cross checks it with the actual mainline volume and ramp volumes in passenger car equivalents to determine if there is lane balance. This check should include consideration of freeway grade and the volume of trucks.

7.9 Lane Reduction

Lane reduction below the basic number of lanes is not permissible through an interchange. Where the reduction in traffic volumes is sufficient to warrant a decrease in the basic number of lanes, a preferred location for the lane drop is beyond the influence of an interchange and preferably at least one half mile from the nearest exit or entrance. It is desirable to locate lane drops on tangent alignment with a straight or sag profile so that there is maximum visibility to the pavement markings in the merge area.

7.10 Route Continuity

Route continuity refers to the provision of a directional path along and throughout the length of a designated route. The designation pertains to a route number or a name of a major highway.

Ideally, the driver continuing on the designated route should travel smoothly and naturally in his lane without being confronted with points of decision. This means the chosen through lane(s) should neither terminate nor exit. It is desirable, therefore, that each exit from the designated route or entrance to the designated route be on the right, i.e., vehicular operation on the through route occurs on the left of all other traffic.

7.11 Weaving Sections

Weaving is created by vehicles entering and leaving the highway at common points, resulting in vehicle paths crossing each other. Weaving normally occurs within an interchange or between closely spaced interchanges.

Desirably on cloverleaf interchanges the distance between loop ramp terminals should not exceed 800–1000 ft. Where the weaving volumes require separations greater than the desirable, consideration should be given to providing a collector distributor road.

The *Highway Capacity Manual*, Transportation Research Board, should be consulted for further information on weaving.

7.12 Access Control

Access rights shall be acquired along interchange ramps to their junction with the nearest existing public road. At such junctions, access control shall extend to the end of the acceleration or deceleration lane, excluding the taper. Desirably the access control should be extended beyond the end of the acceleration or deceleration lane taper a minimum of 100 ft in urban areas and 300 ft in rural areas.

The interior of all ramps and loops at interchanges shall also be acquired. Where access is proposed at new or existing interchange locations, design waivers (submitted as an attachment to the permit application) to Section 7-11 will be granted only after a thorough analysis has been made with respect to the cost of acquisition and impact on safety. For further information on access control, see Section 5-8, "Driveways."

7.13 Bicycle and Pedestrian Accommodations

Bicycle and pedestrian traffic should be accommodated through the use of bicycle and pedestrian compatible roadway treatments or designated bike lanes at all interchange areas, including freeway entrances and exits, where cyclists and pedestrians are legally allowed to operate. For additional guidance, refer to the MUTCD.

7.14 Collector – Distributor Roads

This subsection concerns collector-distributor (C-D) roads within an interchange.

As per AASHTO-*Geometric Design of Highways and Streets*:

"The advantages of using collector-distributor roads within an interchange are that weaving is transferred from the main roadways, single entrances and exits are developed, all mainline exits occur in advance of the structure, and a uniform pattern of exits can be maintained."

Where the weaving volume on a cloverleaf weave exceeds 1000 vph (i.e.: sum of traffic on two adjoining loops), a C-D road should be considered in order to enhance the level of service and safety on the mainline.

The design speed of the C-D road is usually the same as the mainline, but should not be less than 10mi/hr below the design speed of the mainline.

The outer separation between the mainline and the C-D road should desirably be a 10 feet wide concrete island with sloping curb, but should not be less than 6 feet wide. To improve the visibility of the island, delineators shall be installed on the island. White delineators shall be placed 1 foot off the edge of the mainline shoulder, and yellow delineators shall be installed 1 foot off the left edge of the C-D road pavement. The spacing of the delineators shall be in accordance with CD-610-4. The use of concrete barrier curb should be avoided in the outer separation because it would be a potential obstruction and shielding of the approach end can have a high maintenance requirement. However, when it is not practical to widen an existing roadway to provide a minimum 6 feet island, a concrete barrier curb divider may be used. A crash cushion shall be installed on the approach end and delineators installed on the barrier curb in accordance with Subsection 607.03 of the Specifications.

The typical width of the C-D road should be the same as the width of a tangent ramp, therefore, a one lane C-D road should be 22 feet wide, and a two lane C-D road should be 29 feet wide. The number of lanes may vary throughout the C-D road as capacity requirements warrant. The one lane C-D road width at the entrance to the mainline and the width of a one lane ramp entering the C-D road should each narrow down at their physical nose to 17 feet, see Figure 7-B, Case I respectively. The C-D road width at the exit of the mainline and the width of a ramp exiting a C-D road should each widen by 3 feet at their physical nose, see Figure 7-E.

Connections between the mainline and C-D road are called transfer roads. In general, transfer roads are designed as deceleration lanes and acceleration lanes for the exit transfer road and entrance transfer road respectively. A one lane tapered exit design

as per *AASHTO-Geometric Design of Highways and Streets* may be substituted for the one lane deceleration lane (parallel exit) design contained in this manual.

Shoulders should be provided on single or multi-lane C-D roads including those that span several interchanges; shoulder requirements for transfer roads use the same requirements as shoulders on acceleration and deceleration lanes, See Section 5.4. When shoulders are provided, the shoulder width should be 10 to 12 feet on the right and 2 to 4 feet on the left. The lane width shall be 12 feet for one-lane and two-lane C-D roads.

Section 8 -Guide Rail and Median Barriers

8.1 Introduction

These guidelines are based on the Roadside Design Guide, AASHTO, 2011.

The information in this section is intended to serve as guidelines that will assist the designer in determining conditions that warrant the installation of guide rail and the dimensional characteristics of the installations. Also, this section contains information to serve as guidelines to assist the designer in determining conditions that warrant the installation of a median barrier.

It is important that application of these guidelines be made in conjunction with engineering judgment and thorough evaluation of site conditions to arrive at a proper solution.

It should be emphasized that guide rail should not be installed indiscriminately. Every effort should be made to eliminate the obstruction for which the guide rail is being considered.

In some cases, another type of traffic barrier may be more effective than guide rail. For example, obstructions in gores can often be more effectively shielded with a crash cushion. The designer should consider such alternatives and choose the most suitable solution based on safety requirements, economic limitations, maintenance, and aesthetic considerations.

8.2 Guide Rail Warrants

8.2.1 General

Guide rail is considered a longitudinal barrier whose primary functions are to prevent penetration and to safely redirect an errant vehicle away from a roadside or median obstruction.

8.2.2 How Warrants are Determined

An obstruction's physical characteristics and its location within the clear zone are the basic factors to be considered in determining if guide rail is warranted. Although some wide ranges of roadside conditions are covered below, special cases will arise for which there is no clear choice about whether or not guide rail is warranted. Such cases must be evaluated on an individual basis and in the final analysis must usually be solved by engineering judgment. In the absence of pertinent criteria, a cost-effective analysis such as the Roadside Safety Analysis Program (RSAP) could be used to evaluate guide rail needs. The report and its appendices are available for download in PDF format at the following:

http://onlinepubs.trb.org/onlinepubs/nchrp/docs/NCHRP22-27_FR.pdf

8.2.3 Clear Zone

Clear zone is defined as the area starting at the edge of the traveled way that is available for safe use by errant vehicles. The clear zone includes shoulders, bike lanes, acceleration lanes and deceleration lanes. The clear zone for auxiliary lanes that function like through lanes will be measured from the outside edge of the auxiliary lane.

The width of the clear zone (LC) varies with the speed, roadside slope and horizontal roadway alignment. The design speed should be used when determining the clear

zone. Use "Table 2-1 Design Speed vs. Posted Speed" to determine the design speed for locations where the design speed is unavailable.

Figure 8-A contains the suggested range of clear zone distances on tangent sections of roadway based on selected traffic volumes, speed and roadside slopes. Clear zones on land service highways may be limited to 30 feet for practicality and to provide a consistent roadway section if previous experience with similar projects or designs indicates satisfactory performance. According to the Roadside Design Guide, AASHTO, 2011, the designer may provide clear zone distances greater than 30 feet as indicated in Figure 8-A, where such occurrences are indicated by crash history.

Figure 8-B1 and 8-B2 contains examples of determining clear zone distances. More examples and further explanation are contained in the Roadside Design Guide, AASHTO, 2011.

Horizontal alignment can affect the clear zone width. Therefore, clear zone widths on the outside of horizontal curves should be adjusted by multiplying the clear zone width determined from Figure 8-A by the curve adjustment factor in Figure 8-C.

8.2.4 Warrants

A warranting obstruction is defined as a non-traversable roadside or a fixed object located within the clear zone and whose physical characteristics are such that injuries resulting from an impact with the obstruction would probably be more severe than injuries resulting from an impact with guide rail.

A. Non-traversable Roadside

Examples of a non-traversable roadside that may warrant guide rail include rough rock cuts, large boulders, streams or permanent bodies of water more than 2 feet in depth, roadside channels with slopes steeper than 1H:1V and depths greater than 2 feet, embankment slopes and slopes in cut sections as described in the following:

1. Embankment (Fill) Slopes

A critical slope is one in which a vehicle is likely to overturn. Slopes steeper than 3H:1V generally fall into this category. If a slope steeper than 3H:1V begins closer to the traveled way than the suggested clear zone distance, guide rail might be warranted if it is not practical to flatten the slope. Guide rail warrants for critical slopes are shown in Table 8-1.

Table 8-1	
Critical Slope Warrants	
Critical Embankment (Fill) Slopes	Maximum Height Without Guide Rail
1½ H:1V	3 ft.
2H:1V	6 ft.
2½ H:1V	9 ft.

A non-recoverable slope is defined as one that is traversable but the vehicle can be expected to travel to the bottom of the slope before steering recovery can be obtained. Embankments from 3H:1V to steeper than 4H:1V generally fall into

this category. Where such slopes begin closer to the traveled way than the suggested clear zone distance, fixed objects should not be constructed on the slope. Recovery of high speed vehicles may be expected to occur beyond the toe of slope. A clear runout area at the base of these slopes is desirable; see Figure 8-B2 for an example. The designer should evaluate each site before providing non-recoverable slopes without guide rail.

When flattening existing slopes to remove guide rail, the proposed side slopes should be recoverable (4H:1V or flatter). Where embankment slopes are being constructed, the designer should investigate the feasibility of providing a recoverable slope instead of a critical slope with guide rail. Rounding should be provided at slope breaks; see Figures 5-B, 5-B1, 5-B2, 5-H and 5-I.

2. Slopes in Cut Sections

Slopes in cut sections should not ordinarily be shielded with guide rail. However, there may be obstructions on the slope that warrant shielding, such as bridge piers, retaining walls, trees, rocks, etc. that may cause excessive vehicle snagging rather than permit relatively smooth redirection.

Slopes in cut section of 2H:1V or flatter may be considered traversable. As the cut slope steepens, the chance of rollover increases. Where feasible, slopes steeper than 2H:1V should be flattened. If there is a warranting obstruction on the cut slope, the following apply:

- a. Guide rail should be installed if the warranting obstruction is on a slope flatter than 0.7H:1V and is within the clear zone width specified in Figure 8-A for a 3H:1V slope.
- b. Guide rail should be installed if the warranting obstruction is on a slope of 0.7H:1V or steeper and is less than 6 feet (measured along the slope) from the toe of the slope and is within the clear zone width specified in Figure 8-A for a 3H:1V slope.
- c. Guide rail is not required if the warranting obstruction is on a slope of 0.7H:1V or steeper and is 6 feet or more (measured along the slope) from the toe of the slope.

3. Drainage Features

Channels should be designed to be traversable. Where feasible, existing channels should be reconstructed to be traversable. The presence of channels or ditches may be regulated streams, wetlands or open waters. Changes to these channels must be coordinated with the Hydrology and Hydraulic Unit and the applicable e-Team.

Figures 8-U and 8-V show criteria for preferred cross sections for channels. *According to the Roadside Design Guide, AASHTO, 2011:*

"Cross sections shown in the shaded region of each figure are considered to have traversable cross sections. Channel sections that fall outside the shaded region are considered less desirable and their use should be limited where high-angle encroachments can be expected, such as the outside of relatively sharp curves. Channel sections outside the shaded region may be acceptable for projects having one or more of the following characteristics: restrictive right-of-way; environmental constraints; rugged terrain; resurfacing, restoration, or rehabilitation (3R) projects; or low-volume or low-speed roads and streets, particularly if the channel bottom and backslopes are free of any fixed objects or located beyond suggested clear

zone distance. If practical, drainage channels with cross sections outside the shaded regions and located in vulnerable areas may be reshaped and converted to a closed system (culvert or pipe) or, in some cases, shielded by a traffic barrier.”

B. Fixed Objects

Examples of fixed objects that may warrant guide rail are: overhead sign supports, high-level lighting supports, traffic signals and luminaires supports of non-breakaway design, concrete pedestals extending more than 4 inches above the ground, bridge piers, abutments and ends of parapets and railings, wood poles or posts with a cross sectional area greater than 50 square inches (except as modified by Subsection 8.2.4.B.2. “Utility Poles”), and drainage structures.

In no case on new or upgraded guide rail installations shall breakaway, bendaway or non-breakaway design supports, highway lighting, signal poles, signal controller and meter cabinets, trees, utility poles, fire hydrants, mailboxes and signs remain in front of guide rail.

Signal poles shall be located as noted in subsection 12.3.8 “Traffic Signal Standards”. Shielding of steel poles on roadways with posted speeds of 50 mph or greater can be considered when there is a history of run-off-the-road crashes and there is the required recovery area or clear area behind the approach end terminal (see Figures 8-D and 8-P1).

Signs with bendaway (steel U-post) supports may be placed in front of dual faced guide rail in the median. Desirably, allow 7 feet between face of rail element and nearest sign post. If possible, relocate the sign behind guide rail at the nearest structure or place a single post sign inside the dual faced guide rail (between the two rail elements).

Overhead sign supports should be located as close to the right-of-way line as practical. Guide rail protection for all overhead sign supports should be provided regardless of location beyond the clear zone. This will limit severe implications resulting from impacts to the sign support.

1. Trees

Trees are considered fixed objects. However, trees are generally not considered a warranting obstruction for guide rail. The following guidance is provided for the treatment of trees within the clear zone:

- a. On freeways and interstate routes, trees shall not be located within the clear zone.
- b. Although it is desirable to provide a clear zone free of trees on land service roads, it is likely that situations will be encountered where removal of trees within the clear zone cannot be accomplished. For instance, the aesthetic appeal of the trees may cause local opposition to their removal, the trees may not be within the right-of-way, or removal of the trees may not be environmentally acceptable.
- c. In some cases it may be appropriate to plant replacement trees outside the clear zone so that the removal of trees in close proximity to the roadway may be accomplished without public criticism.
- d. Factors such as crash experience, traffic volume, speed, clearance from the traveled way and roadway geometry should be evaluated when determining whether it is appropriate to leave trees within the clear zone.

Sick and diseased trees that are beyond reasonable repair, along with dead trees, trees that cause sight distance problems and trees with a significant crash history shall be removed regardless of public criticism. Also, trees that will be harmed beyond reasonable repair due to construction shall be removed (i.e. new curb that destroys the main root system). The Office of Landscape Architecture should be consulted for the tree's physical assessment.

Trees that have grown behind guide rail, that are less than 4 feet from the face of the rail element, shall be removed regardless of size. Trees, shrubs and overhanging branches shall be removed where they block or obscure horizontal sight distance whether they are behind guide rail or not. As a minimum, branches overhanging the roadway shall be removed up to a height of 16 feet. Trees and shrubs within the roadside recovery area at the approach guide rail terminal should be removed. The following areas should be checked for sight distance problems due to vegetative interference:

- a. Along the inside of horizontal curves (mainline, ramps and jughandles)
- b. Ramp and jughandle entrances and exits
- c. Within the sight triangle at intersections
- d. Sign obstructions

If clearing work is necessary within existing utility lines, the designer should request the utility company to perform regular trimming maintenance (at their cost) in the locations during the utility notification process. However, if clearing work is necessary where poles are to be relocated, then the utility company or the contractor shall be compensated for this work.

Trees removed for safety (i.e. clear zone, sight distance, guide rail and crash cushion recovery areas or clearance to utility lines) are not included in the "No Net Loss Reforestation Calculation". The removal of trees and shrubs may be regulated under the Flood Hazard Area Control Act for riparian zones or the Freshwater Wetlands Protection Act, and should be coordinated with the Hydrology and Hydraulic Unit and the applicable e-Team.

Table 8-2 provides guidance for the location of new plantings on Interstate highways, freeways and land service highways.

Table 8-2	
Guidance for Landscape Plantings	
Interstate and Freeways	Land Service State Highways
No plantings in median areas except for glare screen	Plantings in median area will be limited to flowers and/or small shrubs, unless for glare screen
No plantings in clear zone except for flowers (no shrubs)	Plantings in clear zone will be limited to flowers and small shrubs
Plantings behind guide rail shall be at least: <ul style="list-style-type: none"> • 8' minimum for shrubs* • 10' minimum for shade trees* • 14' minimum for evergreen trees* 	Plantings behind guide rail shall be at least: <ul style="list-style-type: none"> • 6' minimum for shrubs and shade trees* • 10' minimum for evergreen trees*
No plantings within the roadside recovery area (see 8.3.3) except flowers	No plantings within the roadside recovery area (see 8.3.3) except flowers
No plantings within the sight triangle on curves and ramps	No plantings within the sight triangle on curves and ramps
On curves and ramps, plantings shall be placed at least 2' from the sight triangle for shrubs and shade trees and 10' for evergreen trees	On curves and ramps, plantings shall be placed at least 2' from the sight triangle for shrubs and shade trees and 6' for evergreen trees
No planting of trees above underground utility lines	No planting of trees under aerial facilities or above underground utility lines and service connections

* Measured from the back of the guide rail post

2. Utility Poles

Although utility poles have a cross-sectional area greater than 50 square inches (8 inches in diameter), utility poles should not be handled the same as other warranting obstructions. It is questionable whether a safer roadside would result from installing guide rail for the sole purpose of shielding utility poles within the clear zone. Utility poles shall be located as close to the right-of-way line as practical. For the offset to the utility pole from the traveled way, the designer should refer to the current *Utility Accommodation Regulation (NJAC 16:25)*. For a quick and easy reference refer to the current *NJDOT Design Criteria for Above Ground Utilities*.

Desirably on projects where new right-of-way is to be purchased, sufficient right-of-way should be acquired to permit the placement of the poles beyond the clear zone.

On existing highways, where the utility pole offset does not meet the Department standards (*Utility Accommodation Regulation (NJAC 16:25)*), the designer should prepare a crash analysis of existing pole locations to determine if the relocation of the utility poles further from the edge of a through lane is warranted. Any utility pole that has been struck three times or more within three years, will require corrective action. Also, neighboring poles that have been struck a total of three or more times within three years will require

corrective action. If corrective action is necessary, safety measures such as utility pole relocation and/or the improvement of the contributing roadway feature should be considered instead of guide rail.

Utility poles should not be placed in vulnerable locations, such as in gore areas, small islands or on the outside of sharp horizontal curves. For the purpose of these guidelines, a sharp horizontal curve is considered as any horizontal curve with a safe speed less than the posted speed.

In no case, shall utility poles on new or upgraded guide rail installations remain in front of the guide rail. The guide rail offset has preference to existing utility pole offsets where there is sufficient right-of-way. Therefore, where practical, relocate the pole behind the guide rail in lieu of placing the guide rail closer to the road. Guide rail is an obstruction in itself and should be placed as far from the traveled way as possible.

Where utility poles are placed behind guide rail, desirably the face of the pole should be 4 feet or greater from the face of the rail. Where the offset is less than 4 feet, provide reduced post spacing as per *Standard Roadway Construction Detail CD-609-8*. However as a minimum, the face of the pole shall be no closer than 1.5 feet from the face of the rail.

It should be noted that spacing of guide rail posts at long runs of guide rail or at bridge installations may conflict with the spacing of the utility poles. In this case when a pole will be located directly behind a post, the minimum pole offset should be no closer than 23 inches from the face of the rail, which equals 6 inches from the back of the post.

Utility poles shall not be located within the shaded adjacent recovery area shown in Figure 8-D. Also, utility poles should be at least 25 feet or greater in advance of a flared or tangent guide rail terminal.

3. Fire Hydrants

Since fire hydrants do not meet the current AASHTO definition for breakaway design, they fall into the category of fixed objects that may warrant guide rail. The same reasoning applies here as was applicable to utility poles.

The acceptable solution is to locate the hydrants as far from the traveled way as possible. In no case shall fire hydrants be located in front of the guide rail. However, the hydrants must be located to be readily accessible at all times.

Where guide rail is required for some other reason and will be in front of a hydrant, the preferred treatment is to raise the hydrant to permit connection to be made over the guide rail. Usually, the connection may be a maximum of 3 feet above grade. It is the responsibility of the designer to confirm with the local Fire Department that such a treatment is acceptable. A less desirable treatment is to provide a short opening in the guide rail at the hydrant. Where an opening is provided, a flared guide rail terminal, tangent guide rail terminal or anchorage must be provided in accordance with Section 8.3.2. The guide rail must be modified as per *Standard Roadway Construction Detail CD-609-8* when the offset to the hydrant face from the face of rail element is less than 4 feet.

4. Mailbox Supports

Limited crash data has shown that mailbox supports can contribute to the severity of a crash. The following guidelines should be followed on new construction, reconstruction and projects that involve resurfacing:

- a. No more than two mailboxes may be mounted on a single support structure unless the support structure and mailbox arrangement have been shown to be safe by crash testing. Lightweight newspaper boxes may be mounted below the mailbox on the side of the mailbox support.
- b. Mailbox supports shall not be set in concrete unless the support design has been shown to be safe by crash tests.
- c. A single 4 by 4 inch wooden post or a 4 inch diameter wooden post or a 1.5 inch to 2 inch diameter standard steel or aluminum pipe post, embedded no more than 2 feet into the ground, is the maximum acceptable as a mailbox support. A metal post shall not be fitted with an anchor plate, but it may have an anti-twist device that extends no more than 10 inches below the ground surface.
- d. In areas where snow removal is a problem or the mailbox is placed behind guide rail, a cantilever mailbox-type support may be permitted to allow snow plows to sweep under or near mailboxes without damage to their supports. For information on cantilever mailbox design, see the *Roadside Design Guide, AASHTO 2011*.
- e. The post-to-box attachment details should be of sufficient strength to prevent the box from separating from the post top if the installation is struck by a vehicle. The *Roadside Design Guide, AASHTO 2011*, shows acceptable attachment details.
- f. The minimum spacing between the centers of support posts shall be 75 percent of the height of the posts above the ground line.

For more information on mail stop design and mailbox location, see the *Roadside Design Guide, AASHTO 2011*.

C. Pedestrians

Guide rail may be used where there is a reasonable possibility of an errant vehicle encroaching onto a sidewalk where there is considerable pedestrian traffic or into an unprotected area used by pedestrians. Some examples of the latter are where a playground, schoolyard, or a public beach is adjacent to the right-of-way line. The basis for assessing the needs should be the crash experience of the immediate area and the specifics for the cause(s) of the crashes. There may be times when no causative factor can be isolated, and sound engineering judgment must be applied.

This policy is not intended to indiscriminately permit the installation of guide rail at every location where a request for guide rail has been received, but to offer some flexibility to the designer when unique circumstances occur.

There are locations where existing guide rail and the PVI (top of the slope) of a steep slope are both located directly behind a pedestrian sidewalk area. If new guide rail is installed in front of the sidewalk area, the existing guide rail should either be left in place or the existing guide rail should be removed and a fence installed in its place. When guide rail is placed between the roadway and the sidewalk, a rail element may be attached to the back of the guide rail post so that pedestrians are shielded from the exposed back of post. The rail element, if added, shall not be located within the 37.5 foot length of a flared guide rail terminal or within the 50 foot length of a tangent terminal.

8.3 Dimensional Characteristics

NJDOT has chosen the MASH crash tested Midwest Guardrail System (MGS) to use for MASH implementation. This guide rail system has been designed for the high center of gravity vehicles found on today's roadways. The current system includes a higher mounting height (31 inches) and a rail splice that occurs midway between the standard 6'-3" post spacing. In addition, rub rail is no longer required when placing the guide rail at the curb. Details for the guide rail system and for transitioning from the current 31 inch high system to an existing NCHRP 350 27¼ inch high guide rail system are shown in the Department's *Standard Roadway Construction Details*.

8.3.1 Guide Rail Offset

A. Without Curb or Raised Berm in Front of Guide Rail

The mounting height for the guide rail is 31 inches measured from the top of rail to the ground line or gutter line as shown in the Department's *Standard Roadway Construction Detail CD-609-8A*.

A highly desirable characteristic of any roadway is a uniform clearance from the traveled way to the guide rail. It is desirable to place the guide rail at a distance beyond which it will not be perceived as a threat by the driver, see Shy Line Offset in Figure 8-E, Table 1. In general, the following offsets and slopes should be used:

1. To the extent possible, guide rail should be located as far as possible from the traveled way to provide a recovery area for errant vehicles and to provide adequate sight distance along horizontal curves and at intersections.
2. On interstate highways and freeways, the front face of the guide rail should desirably be 4 feet or more from the outside edge of shoulder. Where this offset is not possible, the guide rail should be installed flush with the gutter line.
3. On land service highways where there is no sidewalk and the border area is not used by pedestrians, the front face of the guide rail may be placed any distance from the gutter line; however, an offset of 4 feet or more is preferred.

Where providing an offset of 7 feet or more, the designer is advised that additional right-of-way or slope easements may be necessary to construct a flared offset and/or provide the 5 foot flat area (10H:1V minimum slope) adjacent to a flared guide rail terminal as shown in Figure 8-F. If the purchase of additional right-of-way is infeasible, a tangent terminal should be provided at an offset of 7 feet or more, instead of a flared guide rail terminal. If this is still infeasible, then the guide rail should be installed flush with the gutter line to permit the construction of a flared guide rail terminal with a flared offset and flat area.

B. Curb or Raised Berm in Front of Guide Rail

The mounting height for the guide rail is 31 inches measured from the top of rail to the gutter line or ground line depending upon the offset as shown in the Department's *Standard Roadway Construction Detail CD-609-8A*.

1. Curb or Raised Berm Requirement

Curb or a raised berm in front of guide rail should be avoided, see Section 5.6, "Curbing", for the type and location of curb.

On freeways and Interstate highways, new installations of vertical curb shall not be constructed. However, sloping curb may be constructed on urban freeways and urban and rural Interstate highways but the overall curb height shall not

exceed 4 inches. On land service highways where curb is proposed, the curb height in front of the guide rail shall not exceed 4 inches.

On projects that involve upgrading existing roadways, where there is a curb or a raised berm greater than 4 inches in height in front of guide rail, removal or modification of the curb or raised berm should be the first consideration. If a raised berm in front of the guide rail is necessary, it shall be regraded at 6H:1V and 4 inch maximum height. Where curb in front of guide rail is required, the curb shall be replaced with 4 inch vertical or sloping curb. Also, the curb in front of flared and tangent terminals and 75 feet of curb in advance of the terminals shall be 2 inch vertical curb as shown in *Standard Roadway Construction Details CD-607-2* and *CD-609-5*. Curb in front of a beam guide rail anchorage shall be 2 inch vertical curb as shown in *Standard Roadway Construction Details CD-607-2* and *CD-609-4*.

2. Guide Rail Offset Requirement

If curb (vertical and/or sloping curb) is present and cannot be removed, the preferred guide rail offset for all posted speeds is flush with the gutter line for vertical curb and 6 inches behind the gutter line for sloping curb. Other offset options for locating proposed and existing guide rail at various posted speeds are as follows:

a. Highways With a Posted Speed More than 50 MPH

- i. Proposed guide rail shall be located flush with the gutter line for vertical curb or 6 inches behind the gutter line for sloping curb.
- ii. Existing guide rail that is not located at the gutter line shall be relocated flush with the gutter line for vertical curb or 6 inches behind the gutter line for sloping curb.

b. Highways With a Posted Speed of 40 to 50 MPH

- i. On freeways and Interstate highways proposed guide rail may be located 4 to 12 feet behind the gutter line. However, an offset of 10 to 12 feet is preferred for safe mowing operations.
- ii. On land service highways where there is a sidewalk or sidewalk area used by pedestrians, proposed guide rail may be located 6 to 12 feet behind the gutter line.

c. Highways With a Posted Speed less than 40 MPH:

- i. Proposed guide rail may be located 4 feet or more behind the gutter line of freeway and Interstate ramps.
- ii. On land service highways, proposed guide rail may be located any distance behind the curb. Generally an offset of 6 to 12 feet is preferred.

C. At Embankment Slopes

Where guide rail is located at the top of an embankment slope, the posts should be a minimum of 2 feet from the PVI to the back of the post.

When less than 2 feet is provided, the following post lengths, shown in Table 8-3, should be used:

Table 8-3		
Additional Post Length Requirements Where Distance From PVI to Back of Post is Less Than 2 Feet		
Offset from Back of Post to PVI	Embankment Slopes	Additional Post Length
Less than 2 ft. but greater or equal to 1 ft.	6H:1V or Flatter	No Change
	Steeper than 6H:1V to 3H:1V	1 ft.
	Steeper than 3H:1V to 2H:1V	2 ft.
Less than 1 ft. or at PVI	6H:1V or Flatter	1 ft.
	Steeper than 6H:1V to 3H:1V	2 ft.
	Steeper than 3H:1V to 2H:1V	3 ft.

1. Guide rail shall be placed on slopes 10H:1V or flatter provided the rollover between the pavement slope and the embankment slope is not greater than 10 percent. Rollovers greater than 10 percent are prone to occur where superelevation slopes in the opposite direction of the embankment slope. Where this happens, install guide rail flush to the gutter line.
2. Figure 8-F illustrates the grading treatment for embankment slopes at flared and tangent guide rail terminal.

D. At Fixed Objects

Where guide rail is used to shield an isolated obstruction, it is most important that the guide rail be located as far from the traveled way as possible to minimize the probability of impact. The distance from the face of the rail element to the face of obstruction should desirably be 4 feet or greater. If less than a 4 foot offset must be used, the guide rail system must be modified as shown in *Standard Roadway Construction Detail CD-609-8*. If the guide rail in advance of the obstruction is to be flared (including a flared terminal), the flare should be a minimum of 25 feet from the modified section of guide rail.

E. On Bridges

1. Safetywalks range in width from 1.5 feet to less than 4 feet. On existing freeway and interstate structures with safetywalks, where it is not feasible to remove the safetywalk and provide a concrete barrier shaped parapet, the guide rail shall be carried across the structure along the gutter line. However, on existing freeway and Interstate ramps where the posted speed or advisory speed is 40 mph or less and the safetywalk is 2.5 feet or less in width, it is not necessary to carry guide rail across the structure since vaulting is not likely to occur. In this case, guide rail should only be provided across the structure if the parapet does not meet NCHRP 350 or MASH crash test criteria.
2. Where the roadway approaching a structure has a curb or raised berm, the mounting height of guide rail located at the curb line on the structure shall be measured from the gutter line.
3. The guide rail mounting height shall be measured from the gutter line on those structures where the approach roadway is an umbrella section and the face of guide rail is set flush with the curb face on the structure.
4. Where there is a difference in the offset to the approach guide rail and the offset to the guide rail attachment to the bridge parapet, the straight flare rate

shown in Table 1 of Figure 8-E should begin a minimum of 25 feet prior to the asymmetrical W-beam to thrie beam transition section.

5. Attachment of guide rail to bridges and structures shall be in accordance with the Department's *Standard Roadway Construction Details*, revised or modified Standard Details or Special Details. The designer shall specify at each location on the construction plans the specific guide rail attachment detail to be used and whether it is Type A or Type B.

A TL-2 or TL-3 approach guide rail transition shall be provided when using a Type A attachment. The TL-2 approach guide rail transition shall be used when the design speed is 45 mph or less and the TL-3 approach guide rail transition shall be used when the design speed is greater than 45 mph. The appropriate approach guide rail transition *Standard Roadway Construction Detail* number shall be included on the construction plan.

6. Where there is considerable pedestrian traffic, the guide rail may be set flush to the curb face to physically separate pedestrians from vehicular traffic if feasible (see Section 8.2.4.C).

8.3.2 End Treatments

When the approach end of guide rail is terminated within the clear zone, a flared guide rail terminal or tangent guide rail terminal shall be provided in accordance with (A) and (B) below. When there is insufficient area to install either a flared or tangent guide rail terminal, a crash cushion may be used. See Section 9 for more information on crash cushions.

A. Flared Guide Rail Terminals

1. Flared guide rail terminals shall be used on the approach ends of beam guide rail installations terminating within the clear zone, unless covered by conditions noted in Section 8.3.2.B, 8.3.2.C, 8.3.2.D or 8.3.2.E.

If the approach end of guide rail for opposing traffic is within the clear zone, a flared guide rail terminal shall be used (see Figure 8-I1). The clear zone for the opposing traffic should also be adjusted for horizontal curvature (see Figure 8-C). On two lane highways where passing is permitted, the clear zone shall be measured from the outside edge of the approaching traffic lane.

A 37.5 foot length straight flare shall be used with all flared guide rail terminal end treatments. This flare provides for a flare offset of 4 feet, see *Standard Roadway Construction Details*. The approach end of a flared guide rail terminal shall be placed a minimum distance of 12.5 feet beyond the length of need.

2. A flared guide rail terminal shall not be installed behind a curb greater than 2 inches in height. Where there is curb, the curb in front of the flared guide rail terminal and 75 feet in advance of the flared guide rail terminal shall be 2 inch vertical curb as shown in *Standard Roadway Construction Details CD-607-2* and *CD-609-5*. Where there is sidewalk at a flared guide rail terminal, the sidewalk should be graded at the same rate as the curb transition where possible. See Section 5 for sidewalk grading criteria.
3. A roadside recovery area should be provided behind a flared guide rail terminal installation. See Section 8.3.3 for additional discussion of Roadside Recovery Area.
4. When a flared guide rail terminal is proposed at the approach to a TL-2 or TL-3 approach guide rail transition, the flared terminal shall be a minimum of 15'-

7½" beyond the approach end of the approach guide rail transition at a bridge as shown in Figure 8-O2.

5. Rub rail, reduced post spacing, or double rail elements shall not be used within the 37.5 feet flare of a flared guide rail terminal.
6. Where a flared guide rail terminal is installed along a horizontal curve, see Figure 8-X.
7. The flared terminal pay limit is shown on *Standard Roadway Construction Detail CD-609-5*.

B. Tangent Guide Rail Terminals

1. At locations where it is not possible to construct a flared guide rail terminal with a 4 foot flared offset, a tangent terminal should be used. A tangent terminal can be erected parallel to the roadway without needing a flare to function properly. The approach end of the tangent terminal shall be placed a minimum distance of 12.5 feet beyond the length of need.
2. Where the guide rail is installed flush with the gutter line, a tangent terminal shall be constructed with a straight flare with the approach end of the terminal offset 1 foot from the gutter line to reduce nuisance hits.
3. A roadside recovery area shall be provided behind a tangent guide rail terminal installation. See Section 8.3.3 for additional discussion of Roadside Recovery Area.
4. Where a tangent guide rail terminal is installed along a horizontal curve, see Figure 8-Y.
5. A tangent guide rail terminal shall not be installed behind a curb greater than 2 inches in height. Where there is curb, the curb in front of the tangent guide rail terminal and 75 feet in advance of the tangent guide rail terminal shall be 2 inch vertical curb as shown in *Standard Roadway Construction Details CD-607-2* and *CD-609-5*. Where there is sidewalk at a tangent guide rail terminal, the sidewalk should be graded at the same rate as the curb transition where possible. See Section 5 for sidewalk grading criteria.
6. Rub rail, reduced post spacing, or double rail elements shall not be used within 50 feet of the approach end of a tangent guide rail terminal.
7. When a tangent guide rail terminal is proposed on the approach to a TL-2 or TL-3 approach guide rail transition, the tangent terminal shall be a minimum of 3'-1½" beyond the approach end of the approach guide rail transition at a bridge as-shown in Figure 8-O2.
8. The tangent terminal pay limit is shown on *Standard Roadway Construction Detail CD-609-5*.

C. Beam Guide Rail Anchorages

1. On a one-way roadway or a divided roadway with a non-traversable median, trailing ends of guide rail installations should be anchored with a beam guide rail anchorage, as shown in *Standard Roadway Construction Detail CD-609-4*.
2. In special cases, where the approach end of a guide rail installation is located so that an end hit is unlikely, the end may be anchored with a beam guide rail anchorage as shown in *Standard Roadway Construction Detail CD-609-4*. One example would be where the approach end of a guide rail installation for opposing traffic is outside the clear zone, see Figure 8-I1, Condition 1.

3. A clear area should be provided behind beam guide rail anchorages. The clear area extends 37.5 feet upstream from the end post of the anchorage and varies in width from 2.5 feet to 10 feet, see Figure 8-I2.
4. A minimum of 2 feet must be provided between the back of the anchorage posts and the PVI of a fill slope.
5. Where there is curb, the curb in front of the anchorage shall be 2 inch vertical curb as shown in *Standard Roadway Construction Details CD-607-2* and *CD-609-4*. Where there is sidewalk at a beam guide rail anchorage, the sidewalk should be graded at the same rate as the curb transition where possible. See Section 5 for sidewalk grading criteria.

D. Controlled Release Terminals (CRT)

The design shown in Figure 8-P1 is based on an intersection angle of 90 degrees. See Note E in Figure 8-P1 when the intersection angle is considerably different than 90 degrees. In addition, the following criteria also apply:

1. If a raised berm in front of a CRT cannot be removed, it shall be regraded at 15H:1V. Where curb in front of the CRT cannot be removed, curb shall be no higher than 2 inches.
2. A clear area free of any obstructions and graded at 2H:1V or flatter shall be provided behind the CRT. See Figure 8-P1 and *Standard Roadway Construction Detail CD-609-6* for the required clear area dimensions.
3. Since the rail height of the CRT is 27¼ inches, a 25 foot vertical transition as shown in *Standard Roadway Construction Detail CD-609-8* is required to attach the CRT to 31 inch high standard guide rail. The transition begins at the CRT line post.
4. Figure 8-P2 shows the minimum length of guide rail required when a CRT is to be installed in advance of an approach guide rail transition. If the minimum length cannot be provided, a compressive crash cushion should be installed on the approach end of the guide rail.

E. Buried Guide Rail Terminal

In cut sections, the approach end of guide rail should be buried in the backslope as shown in Figure 8-N and in *Standard Roadway Construction Detail CD-609-9*. A straight flare should be used where the guide rail is buried in a cut slope. Table 1 of Figure 8-E shows the straight flare rate allowable for various speeds. A minimum L.O.N. measured from the point where the guide rail crosses the PVI of the foreslope and backslope to the obstruction being shielded shall not be less than 75 feet.

In cut sections where the border area slopes towards the roadway, the clearance to the top of rail along the flared portion of the guide rail shall be maintained at 31 inches above the ground line as shown in Figure 8-N, FORESLOPE GRADED TOWARD ROADWAY - SECTION VIEW.

In cut sections where the border area slopes away from the roadway, the height of the flared portion of the guide rail shall be constant relative to the normal guide rail offset until the guide rail is buried in the backslope as depicted in Figure 8-N, FORESLOPE GRADED AWAY FROM ROADWAY - SECTION VIEW. If the clearance from the ground to the bottom of rail exceeds 21 inches, rub rail and 8 foot long posts shall be used throughout the portion where the clearance exceeds 21 inches.

To provide the necessary anchorage, the rail shall be attached to the last two posts according to *Standard Roadway Construction Detail CD-609-9*. The beginning of

the flare and the location of the buried end post shall be indicated by station and offset on the construction plans.

F. Existing Slotted Rail Terminals (SRT), Breakaway Cable Terminals (BCT), ET-PLUS and Eccentric Loader Terminals (ELT)

An existing SRT, BCT, ET-PLUS or ELT shall be replaced with the end treatments previously discussed in this section at the following locations:

1. An SRT, BCT, ET-PLUS or an ELT that must be replaced due to crash damage shall be upgraded with an end treatment other than an SRT, BCT, ET-PLUS, or an ELT. An SRT can be replaced in kind if it has a minimum adjacent recovery area of 175 feet long.
2. Any SRT, BCT, ET-PLUS or ELT installed within the clear zone shall be replaced in conjunction with regularly scheduled roadway work in the same area with an end treatment other than an SRT, BCT, ET-PLUS or an ELT. An SRT does not have to be replaced if it has a minimum adjacent recovery area of 175 feet long.

Where a BCT or an ELT require replacement in (1) and (2) above, upgrade the entire run of guide rail attached to the BCT or ELT since the guide rail is past its service life.

8.3.3 Roadside Recovery Area

Research has shown that over half of all fatal guide rail collisions involve a secondary event, either a second impact or a rollover. Many of these secondary events, e.g. trees, poles, and rollovers, typically carry a much higher fatality risk than a guide rail impact. Therefore, a roadside recovery area void of fixed objects is desirable, adjacent to, and behind the approach guide rail terminal and guide rail anchorage. In some cases, however, providing even a minimum runout area may not be practical because of physical constraints such as right-of-way, environmental concerns, or inadequate resources.

Figure 8-D shows the roadside recovery area that should be provided at flared and tangent guide rail terminals and Figure 8-I2 shows the clear area behind a beam guide rail anchorage.

The adjacent recovery distance (A) behind guide rail in Figure 8-D should desirably extend from the beginning of the guide rail terminal to the obstruction. In some cases, however, where it is not practical to provide the desirable distance, the minimum adjacent recovery distances (A) shown in Table 1 of Figure 8-D should be provided behind the guide rail. On land service highways where the length of guide rail in advance of the obstruction is restricted due to the location of driveways, intersecting streets or other features, and the minimum adjacent recovery distances (A) shown in Table 1 of Figure 8-D cannot be provided, the adjacent recovery distance will extend from the guide rail terminal to the obstruction.

An advanced recovery area shown in Figure 8-D should also be provided. On land service highways where there are utility poles, the location of utility poles should comply with the criteria in Subsection 8.2.4.B.2.

Desirably the lateral recovery distance (B) should equal the distance from the face of the guide rail terminal to the back of the obstruction. When it is not practical to provide the desirable lateral recovery distance, the minimum lateral recovery distances (B) shown in Table 1 of Figure 8-D should be used. If the distance from the face of the guide rail to the back of the obstruction is less than the minimum lateral recovery distance (B) shown in Table 1 of Figure 8-D, the minimum lateral recovery

distance should be provided. However, in no case should the lateral recovery distance (B) extend beyond the clear zone or the R.O.W. line whichever is less.

On land service highways, the minimum lateral recovery distance (B) in Figure 8-D may be reduced when the typical lateral recovery distance in advance of the terminal is less than shown in Table 1 of Figure 8-D. The recovery area directly behind a terminal ideally should be at least as wide as the roadside clear distance immediately up stream of the terminal. The lateral recovery distance (B) that is selected should be consistent with that available elsewhere along the highway and is measured from the edge of roadway to existing roadside obstructions (trees, rock cuts, etc.).

In addition to providing a clear area void of fixed objects, proper grading in advance of, adjacent to, and behind the terminal is required to be sure the vehicle remains stable after hitting the terminal. Based on the 2003-2005 New Jersey Crash Record System (NJCRASH) and the 2000-2005 Fatality Analysis Reporting System (FARS), 14% of all fatal guide rail crashes in New Jersey resulted in rollover. The Standard Grading treatment shown in Figure 8-F shall be used for all flared terminals and wherever practical for tangent terminals. However, when upgrading existing guide rail sites or when there are site limitations at new guide rail locations (limited R.O.W., environmental constraints, etc.), the Alternate Grading treatment in Figure 8-F may be used for tangent terminals only.

The designer must provide on *Standard Roadway Construction Detail CD-609-10* the required longitudinal (A) and lateral (B) recovery distances for each flared and tangent guide rail terminal site. Furthermore, additional quantities for clearing site, selective clearing, and/or tree removal, and the necessary earthwork to provide the proper grading shown in Figure 8-F will be required to be shown on the contract plans. Also, the location for each site along with the type of grading treatment (Standard or Alternate) shall be provided on *Standard Roadway Construction Detail CD 609-10*.

8.3.4 Approach Length of Need (L.O.N.)

The approach length of need (L.O.N.) is the minimum length of guide rail required in advance of the warranting obstruction to shield it effectively (See Figure 8-E). The minimum length of guide rail in advance of an obstruction including the approach terminal shall not be less than the minimum adjacent recovery area (A) shown in Table 1 of Figure 8-D.

A. On Embankment Slopes

The approach L.O.N. on embankment (fill) slopes should be determined in accordance with Figures 8-E and 8-G. On a two-way, undivided highway or on a divided highway with a narrow traversable median, an "approach end" treatment may be required for both directions of traffic; see Figure 8-I1 to determine the approach L.O.N. for opposing traffic on the embankment (fill) slopes.

The guide rail treatment for critical embankment slopes is shown in Figure 8-H.

Figure 8-J, 8-K and Figure 8-L illustrate the guide rail layout when shielding an obstruction on an embankment slope in the median.

B. In a Cut Section

See Figure 8-M for an example of determining L.O.N. in a cut section.

When the distance from the ground to the bottom of the guide rail exceeds 21 inches, a rub rail shall be provided from that point to the slope. See Section 8.3.2.E for further guidance.

C. At Driveways

If the existing driveway falls outside the L.O.N., design guide rail as shown in Figure 8-E.

Where existing driveways are located within the L.O.N., the designer's first consideration should be to relocate the driveway as far away from the warranting obstruction as the property line allows. If the relocated driveway falls outside the L.O.N., design guide rail as shown in Figure 8-E.

If a driveway cannot be relocated beyond the L.O.N., use treatments shown in Figures 8-O1 or 8-P1. The CRT shown in Figure 8-P1 is the preferred design. Where the minimum functional length of a flared guide rail terminal in Figure 8-O1 is longer than the space available from the obstruction to the driveway and the right-of-way purchase is impractical for the CRT in Figure 8-P1, consideration should be given to using a crash cushion.

Driveway openings sometimes fall within a continuous guide rail run. An example of a guide rail treatment at this location is shown in Figure 8-Q.

D. At Gore Areas

It is desirable to provide a traversable and unobstructed gore area since the gore area may serve as a recovery area for errant vehicles. Every effort should be made to keep the gore area clear of warranting obstructions. However, urban areas, wetlands, parklands, etc. can put restrictions on this policy by placing warranting obstructions, such as critical embankment slopes, parapets or abutments close to gore areas. The closer the obstruction is to the gore area, the closer the L.O.N. is to the gore area, and the more limited the guide rail treatment becomes. Figures 8-R and 8-S provide guide rail treatment examples for gore areas, starting from less restricted or open gore areas in Figure 8-R to more restricted or limited gore areas in Figure 8-S.

E. In Medians

In very wide medians where an obstruction is within the clear zone from only one direction, the approach L.O.N. should be determined as shown in Figures 8-E and 8-G. For medians that do not require median crossover protection, but the obstruction is within the clear zone for both directions, Figure 8-J illustrates the guide rail layout for shielding the obstructions.

For medians that do require median crossover protection, Figures 8-K and 8-L illustrate the typical guide rail layout. However, when beam guide rail, dual faced is installed along one edge of the roadway as illustrated in Figure 8-L, any obstruction in the median shall be shielded regardless of its offset. To determine the required L.O.N., L_H shall be measured from the edge of traveled way to the back of the obstruction and when determining the L.O.N. for the approach end of a bridge parapet, L_H shall be measured to the back of the trailing parapet.

8.3.5 Nonvegetative Surface Under Guide Rail

In order to reduce soil erosion and highway maintenance costs associated with spraying vegetation killer or trimming vegetation underneath guide rail, nonvegetative surfaces should be applied underneath guide rail as follows:

Table 8-4	
Guide Rail Types	
Conditions Warranting Use of Nonvegetative Surfaces *	
Existing Guide Rail	Where upgrading Where regrading berms Where resetting guide rail
New Guide Rail	All cases

* The following are examples of exceptions to Table 8-4:

- Areas adjacent to properties where adjacent property owners maintain NJDOT R.O.W.
- Where Environmental permits would be required (i.e.: stormwater management (Flood Hazard Control Act), riparian, freshwater or tidal wetlands, pinelands), individual sections of guide rail 1,000 feet or less in length may be exempt from nonvegetative surfaces. Caution should be taken on eliminating nonvegetative surfaces from underneath guide rail next to slopes 2 to 1 or steeper. Extreme caution should be taken where runoff from slope can enter a C-1 waterway.

All nonvegetative surfaces require maintenance to spray emergent non-selective herbicide treatment for total control of vegetation on the nonvegetative surface area.

Porous nonvegetative surfaces should be the first choice when designing guide rail. Nonvegetative Surface, Hot Mix Asphalt (HMA) is impervious and should be used as little as possible. It also requires a "leave out" which increases its cost. When Nonvegetative Surface, Hot Mix Asphalt (HMA) is to be constructed, a square or round "leave out" must be provided at each post. The dimension and material for the "leave out" is shown in *Standard Roadway Construction Detail CD-608-1*.

The net increase in impervious surface, including Nonvegetative Surface, Hot Mixed Asphalt, should be kept below one-quarter acre per project as per storm water management requirements. Also, the net increase in area of disturbance should be kept below one acre per project. If these requirements are exceeded, and other permits (IE: wetlands, tidal, C.A.F.R.A., etc.) are required by the Division of Land Use Regulations of the NJDEP for the project; then NJDEP will review the Storm Water Management Plan as part of the permit review. If these requirements are exceeded and no other permit is required by the Division of Land Use Regulations of the NJDEP for the project, the Hydrology and Hydraulic Unit of the Bureau of Landscape Architecture and Environmental Solutions at NJDOT will review the Storm Water Management Plan.

Also, the thresholds for impervious surface and the area of disturbance are much smaller for stormwater management in the Pinelands and in the D & R Canal Commission, coordinate with the Hydrology and Hydraulic Unit.

Several types of porous nonvegetative surfaces are available in order to keep the net impervious surface to a minimum:

- Nonvegetative Surface, Porous Hot Mix Asphalt: NJDEP considers Porous HMA as impervious cover for stormwater management (Flood Hazard Control Act).

The Delaware and Raritan Canal Commission considers Porous HMA as porous cover for stormwater management.

- Nonvegetative Surface, Polyester Matting: NJDEP considers Polyester Matting as porous cover for stormwater management (Flood Hazard Control Act).
- Nonvegetative Surface, Broken Stone: NJDEP considers Broken Stone porous for wetland transition areas and for stormwater management (flood hazard control act). The NJ Pinelands Commission considers Broken Stone as porous for stormwater management.

Where there is currently no nonvegetative surface under the guide rail, all types of nonvegetative surfaces are considered as vegetative disturbance in a Riparian zone and will require a permit from NJDEP.

Porous types are limited on where they can be placed as shown in Table 8-5.

Table 8-5							
Placement of Porous Nonvegetative Surfaces Based on Guide Rail Offset							
	Curb Section	Berm Section			Umbrella Section		
	Guide Rail Offset	Guide Rail Offset			Guide Rail Offset		
Nonvegetative Surface	All	0'	4'	6' or more	0'	4'	6' or more
Porous HMA 4" Thick	Yes	Yes	No	Yes	Yes	No	Yes
Porous HMA 6" Thick	No	No	Yes	No	No	Yes	No
Polyester Matting	Yes	No	No	Yes	No	No	Yes
Broken Stone 4" Thick*	Yes	No	No	Yes	Yes	Yes	Yes

* New Broken Stone installations must have a minimum shoulder width of 8 feet adjacent to it. Broken Stone is limited only in areas where broken stone exists. For example: additional guide rail is being provided in a project and the existing guide rail within the project limits has broken stone underneath. Concurrence is needed from the Regional Maintenance Engineer.

Broken Stone is the least expensive nonvegetative surface, followed by Porous HMA, HMA, and then Polyester Matting.

The nonvegetative surface shall be constructed as shown in *Standard Roadway Construction Detail CD-608-1*.

8.3.6 Sidewalks

Where there is considerable pedestrian traffic, the guide rail may be set flush to the curb face to physically separate pedestrians from vehicular traffic if feasible (see

Section 8.2.4.C). The minimum width of sidewalk behind the post shall conform to Section 5.7.

Where guide rail is to be installed flush with the gutter line and the concrete sidewalk extends to the back of curb, a "leave out" shall be provided at each post to minimize the need to repair the sidewalk should the guide rail be struck. The "leave out" is typically square (15" x 15") or round (15" diameter).

The "leave out" shall be constructed as shown in *Standard Roadway Construction Detail CD-608-1*.

8.3.7 Underground Structures

The location of inlets and underground structures such as, drainage pipes, subbase outlet drains, culverts, utility lines, fiber optic lines, etc. may conflict with the placement of guide rail posts. When it is not practical to adjust the location of an inlet, underground structure or the guide rail posts, the designer has the option of adding additional blockouts, omitting one to three guide rail posts (12'-6", 18'-9" or 25'-0" unsupported span lengths) or attaching the guide rail to a concrete sidewalk.

A. Additional Blockouts

Should the designer elect to provide additional blockouts, one additional blockout may be provided at each post for any length of guide rail. However, if two additional blockouts are required, they are limited to only one post in any 75 feet of guide rail. Additional blockouts are not permitted within the limits of guide rail terminals.

B. Omitting one post (12'-6" Unsupported Span)

When it is necessary to eliminate a post to avoid a conflict with an inlet, underground utility or underground structure, the following apply:

1. A minimum of 56.25 feet (nine 6'-3" post spaces) between two consecutive post omissions.
2. The omitted post must be a minimum of 62.5 feet (ten 6'-3" post spaces) from the approach end of a tangent terminal, 68.75 feet (eleven 6'-3" post spaces) from the approach end of a flared terminal, and 31.25 feet (five 6'-3" post spaces) from the beginning of a flare or reduced post spacing.
3. An omitted post must be a minimum of 62.5 feet (ten 6'-3" post spaces) from the last post of a beam guide rail anchorage.
4. The omitted must be a minimum of 37.5 feet (six 6'-3" post spaces) from the upstream end of a thrie beam to W-beam asymmetrical transition.
5. The omitted post must be at least 43.25 feet (seven 6'-3" post spaces) from an outer CRT post of an 18'-9" or 25'-0" unsupported span.
6. Fixed objects within the limits of the unsupported span must be a minimum of 5 feet behind the face of rail (see *Standard Roadway Construction Detail CD-609-8A*).
7. Where there is curb at the omitted post, the curb height shall not be greater than 2 inches for 18'-9" on both the approach and trailing end of the omitted post.
8. The 12'-6" unsupported span shall be constructed as shown in *Standard Roadway Construction Detail CD-609-8A*.
9. The designer must show the location of a proposed 12'-6" unsupported span on the construction plans.

C. Omitting Two or Three Posts (18'-9" or 25'-0" Unsupported Span)

When it is necessary to eliminate two or three posts to avoid an inlet or underground structure the following apply:

1. A minimum of 62.5 feet (ten 6'-3" post spaces) of tangent guide rail is required between the outer CRT posts of consecutive unsupported spans.
2. The outer CRT posts must be a minimum of 62.5 feet (ten 6'-3" post spaces) from the approach end of a tangent terminal and 87.5 feet (fourteen 6'-3" post spaces) from the approach end of a flared terminal.
3. The outer CRT posts must be a minimum of 50 feet (eight 6'-3" post spaces) from the beginning of a guide rail flare.
4. The outer CRT posts must be a minimum of 62.5 feet (ten 6'-3" post spaces) from the last post of a beam guide rail anchorage.
5. The outer CRT posts must be a minimum of 37.5 feet (six 6'-3" post spaces) from a thrie beam to W-beam asymmetrical transition section.
6. Fixed objects within the limits of the unsupported spans shall be a minimum of 7 feet behind the face of rail for an unsupported length of 18'-9" and 8 feet for an unsupported span length of 25'-0".
7. Where there is curb within the unsupported span, the curb height shall not be greater than 2 inches. The 2 inch maximum curb height should begin a minimum of 25 feet in advance of the first CRT post on the approach end and continue for a minimum of 25 feet past the last CRT post on the trailing end.
8. If the unsupported span is over a culvert, the culvert headwalls shall not extend more than 2 inches above the ground line.
9. If there is a fill slope behind the CRT posts on either side of the unsupported length, a minimum of 2 feet must be provided between the back of post and the PVI of the fill slope.
10. If there is a vertical drop off behind the unsupported span, the face of rail must be a minimum of 3 feet from the drop off.
11. Unsupported span lengths of 18'-9" and 25'-0" shall be constructed as shown in *Standard Roadway Construction Detail CD-609-8A*.
12. The designer must show the location of a proposed unsupported span including the length of the unsupported span on the construction plans.

D. Concrete Sidewalk

When an underground structure would require an unsupported span length greater than 25'-0", an 8" thick sidewalk with guide rail bolted to the sidewalk may be provided. The width of the sidewalk shall be the same as required for the nonvegetative surface shown in Standard Roadway Construction Detail CD-608-1. Standard Roadway Construction Detail CD-609-11 illustrates the method for attaching guide rail to a sidewalk.

8.3.8 Guide Rail Details

The dimensions and other characteristics of beam guide rail posts, rail elements, fasteners, etc. are shown in the *Standard Roadway Construction Details*.

8.3.9 General Comments

- A. All new guide rail installations shall be constructed 31 inches high, see *Standard Roadway Construction Details*. The 31 inch high guide rail has a construction tolerance of +3/-3 inches.
- B. Existing guide rail within the limits of a reconstruction project shall be replaced if it does not meet current offsets, height or splice location as shown in the *Standard Roadway Construction Details*. However, existing NCHRP 350 (i.e.: 27¼ inch high guide rail with synthetic blockouts) that does not need to be reset may be retained provided it is less than 20 years old (service life). The height of existing NCHRP 350 guide rail that is to remain must be between 26½ and 29 inches high.
- C. On improvement projects to enhance safety, maintenance guide rail replacement projects and preventive maintenance projects, existing NCHRP 350 guide rail may be retained provided it is less than 20 years old. However, when at least 50 percent of an existing guide rail run is repaired, lengthened, reset or upgraded, then the entire run where practical shall be upgraded to the current 31 inch high standard including the approach guide rail transition and/or the end treatment.
- D. When only a portion of the existing guide rail is to be upgraded to the 31 inch height, the guide rail shall be transitioned as shown in the *Standard Roadway Construction Detail CD-609-8*.
- E. Only NCHRP 350 guide rail (27¼ inch high guide rail with synthetic blockouts) can be left in place if the guide rail is less than 20 years old. NCHRP 230 guide rail (rail elements connected without rectangular washers to 14 inch high steel blockouts on 6' long posts) and Pre-NCHRP 230 guide rail (rail elements connected with rectangular washers to 13" high steel blockouts on 5'-9" long posts) shall not be reset. Full replacement is the only option for NCHRP 230 and Pre-NCHRP 230 guide rail.
- F. Guide rail should not restrict sight distance. Sight distances should be checked when guide rail is to be installed at intersections, ramp terminals, driveways, along sharply curving roadways, etc. If the sight distance is determined to be inadequate, the guide rail placement shall be adjusted.
- G. Project limits should end outside the limits of a guide rail run where practical.
- H. Gaps of 200 feet or less between individual guide rail installations should be avoided where possible.
- I. Guide rail should not be installed beyond the right-of-way unless easements or necessary right-of-way is acquired.
- J. For the guide rail treatment at adjacent bridges, see *Standard Roadway Construction Detail CD-609-7A*. The purpose of the guide rail between the bridges is to protect mower operators from the drop off and to potentially stop a slow moving (10 mph or less) errant vehicle from encroaching into the area under the bridges. Guide rail between parapets is not required if there is a concrete connecting wall 2.25 feet high (minimum) between parapets.
- K. Proposed guide rail set flush with the curb line along intersection radius returns should be checked with a truck turning template. Existing guide rail along radius returns that experience truck overhang or oversteering crashes shall either be reset farther from the curb line or redesign the radius returns for a larger design vehicle.

- L. The preferred method for locating all end treatments on construction plans is to dimension from physical objects (i.e. lateral offset from edge of road, longitudinal dimensions from utility pole). Another method is by station and offset.
- M. The grading work necessary for the construction of flared and tangent guide rail terminals shall be shown on the construction plans. The grading shall conform to the *Standard Roadway Construction Detail CD-609-10*.
- N. Conduits

The plans shall indicate the location of existing conduits or shall include a notation where there is a possibility of conflict in driving the guide rail posts.

8.4 Median Barrier

A median barrier is a longitudinal system used to prevent an errant vehicle from crossing that portion of a divided highway separating traveled ways for traffic in opposite directions.

8.4.1 Warrants for Median Barriers

A. Interstate and Freeways

Figure 8-T presents the warrants for median barriers on high speed, access-controlled highways with traversable slopes 10H:1V or flatter.

When the need for a median barrier is determined to be optional from Figure 8-T, an evaluation of the cross median crash history should be made to determine if a median barrier is warranted regardless of the median width and volume. The warrant for a median barrier based on crash history should meet one of the following conditions:

1. 0.50 cross median crashes per mile per year of any crash severity
2. 0.12 fatal cross median crashes per mile per year

Note: The calculation of conditions (1) and (2) above requires a minimum of three crashes occurring within a five year period.

Research of cross median crashes indicate that crashes are more likely to occur within one mile of an interchange and this factor has been included as a median barrier warrant in Figure 8-T.

Figure 8-T depicts the relationship of low ADT's to median widths less than 60 feet to determine if a median barrier is warranted. As presented in Figure 8-T, if the median width is 60 feet or less and the ADT is greater than 50,000 a median barrier is warranted. At low ADT's, the probability of a vehicle crossing the median is relatively small. Thus, for ADT's less than 20,000 and median widths within the optional areas of Figure 8-T, a median barrier is warranted only if there has been a history of cross-median crashes. Likewise, for relatively wide medians the probability of a vehicle crossing the median is also low. Thus, for median widths greater than 60 feet and within the optional area of the figure, a median barrier may or may not be warranted, again depending on the cross-median crash history.

B. Land Service Highways

Careful consideration should be given to the installation of median barriers on land service highways or other highways with partial control of access. Problems are created at each intersection or median crossover because the median barrier must be terminated at these points.

An evaluation of the number of crossovers, crash history, alignment, sight distance, design speed, traffic volume and median width should be made before installation of median barriers on land service highways. Each location should be looked at on a case-by-case basis. A median barrier should be installed if the crash history meets either of the conditions in (1) and (2) above for Interstate and freeways. For the clear zone for median cross over protection on land service highways, see Figure 8-A.

8.4.2 Median Barrier Type

Median barrier type, when warranted, is related to median width as shown in Table 8-6.

Table 8-6	
Median Width vs. Median Barrier Type	
Median Width	Median Barrier Type
Up to 12 ft.	Concrete Barrier Curb
13 ft. to 26 ft.	Concrete Barrier Curb (Preferred Treatment) or Beam Guide Rail, Dual Faced or Modified Thrie Beam, Dual Faced
Above 26 ft.	Beam Guide Rail, Dual Faced or Modified Thrie Beam, Dual Faced

It is recommended to use modified thrie beam, dual faced in lieu of beam guide rail, dual faced in medians where one of the following occurs:

1. The horizontal radius of the roadway is less than 3,000 feet or there is a split profile with 6H:1V side slopes or steeper creating opposing roadways with different elevations.
2. Guide rail is placed flush with the edge of a shoulder 5 feet or less in width.
3. There are 12 percent or more trucks in the project area.
4. The traffic volume is greater than 15,000 vehicles per lane (IE: 4 lane section > 60,000 AADT).

On reconstruction projects, existing dual faced beam guide rail in the median shall be replaced with 31 inch high dual faced beam guide rail. However, dual faced thrie beam guide rail should be installed to replace the existing dual faced beam guide rail when the above criteria are applicable. Existing NCHRP 350 dual faced guide rail (27¼ inch high guide rail with synthetic blockouts) can be left in place if it is less than 20 years old.

It is recommended to use 42" concrete barrier curb in lieu of 32" concrete barrier curb in medians where one of the following occurs:

1. The horizontal radius of the roadway is less than 3,000 feet.
2. There are 12 percent or more trucks in the project area.
3. The traffic volume is greater than 15,000 vehicles per lane (IE: 4 lane section > 60,000 AADT).

Where barrier curb is used to shield an obstruction (bridge piers, abutments, sign bridges, etc.), a minimum offset of 3.25 feet from the gutter line to the face of the

obstruction should be used, since high profile vehicles have a tendency to lean when impacting barrier curb at a high speed (60 mph or greater) and angle (25 degrees) and may strike the obstruction behind it, see Figure 5-K.

8.4.3 Median Barrier Location

Roadside slopes between the traveled way and the median barrier can have a significant effect on the barrier's impact performance. When a vehicle traverses a roadside slope in the median, the vehicle's suspension system can be compressed or extended. As a result, a vehicle that traverses a roadside slope prior to impact with beam guide rail, dual faced beam guide rail or dual faced modified thrie beam guide, a vehicle may go over or under the rail, or snag on the support posts. For concrete barrier curb, a vehicle could go over the barrier, or the barrier could impart an additional roll moment thus increasing the potential for vehicle rollover.

The following guidelines are recommended for the placement of median barriers:

A. Concrete Barrier Curb

Concrete barrier curb is normally placed at or near the centerline of the median. The area between the traveled way and the concrete barrier curb shall be paved and the slope should not exceed 10 percent.

B. Beam Guide Rail, Dual Faced or Modified Thrie Beam, Dual Faced

1. Umbrella Sections

In umbrella sections, dual faced beam guide rail or dual faced modified thrie beam should be placed a minimum of 6 feet from the centerline of the median swale when the median slopes are 10H:1V or flatter (Figure 8-W1). The centerline of the median swale is determined by the centerline of the median inlets.

Existing modified thrie beam guide rail, dual faced may be retained on a 6H:1V side slope, provided the face of rail is installed 6 feet from the centerline of the median swale and a minimum of 12 feet from the slope break with rub rail installed on the swale side of the barrier (Figure 8-W2).

Where medians have 6H:1V side slopes, dual faced beam guide rail or dual faced modified thrie beam shall be installed 2 feet in advance of the slope break with rub rail installed on the swale side of the barrier (Figure 8-W3).

For median slopes that are steeper than 6H:1V, beam guide rail or modified thrie beam shall be placed on both sides of the median a minimum of 2 feet in advance of the slope break (Figure 8-W4).

Where the median is on a split profile (opposing roadways constructed with different elevations) and the cross slope from the higher roadway is equal to or greater than 6H:1V, the dual faced beam guide rail or modified thrie beam guide rail should be placed on the high side of the median 2 feet in advance of the slope break with the rub rail installed on the swale side of the barrier (Figure 8-W5).

Where there is insufficient width between the edge of shoulder and the slope break to provide the 2 foot offset, the face of the barrier shall be placed flush with the edge of shoulder and additional post lengths provided in accordance with Table 8-3.

2. Curbed Sections

Where proposed curb is required in narrow medians, the preferred treatment is to use concrete barrier curb.

3. Existing Curbed Sections

The preferred treatment for existing unprotected curbed medians up to 26 feet wide is to replace with concrete barrier curb and shoulders. This reduces maintenance costs and keeps drainage out of the lanes.

If it is not practical to install concrete barrier curb and shoulder, as mentioned above, due to environmental issues do either one of the following:

- a. Convert the curbed section to an umbrella section with dual faced beam guide rail or dual faced modified thrie beam.
- b. Reduce curb height to 4 inches or less and provide dual faced beam guide rail or modified thrie beam at the gutter line on one side of the median.

In (a) and (b) above, place a nonvegetative surface across the entire median if mowing and trash collection is a problem due to safety and median width.

8.4.4 Emergency and Maintenance U-Turns

Median openings for emergency vehicles are sometimes provided on land service highways, Interstates, and freeways, see Section 6.5.5 for location of emergency U-turns.

Where continuous median crossover protection is provided, a need may arise to provide median U-turns for maintenance vehicles (lawn mowers, etc.). Maintenance U-turns should be provided approximately every 1.5 to 2 miles at bridge piers or overhead sign structures in wide grass medians where no emergency U-turns exist. See Figure 8-K for the design of maintenance vehicle U-turns at bridge piers or overhead sign structures. Do not place these maintenance vehicle U-turns at every bridge pier or overhead sign structure.

8.4.5 Median Barrier End Treatments

A. Crash Cushion

The approach end of new or existing concrete barrier curb within the median including intersections and openings for emergency vehicles shall be protected with a compressive crash cushion regardless of the posted speed.

When terminating the trailing end of barrier curb separating same direction traffic or outside the clear zone, a barrier curb tapered end as shown in the *Standard Roadway Construction Detail CD-607-6* should be used.

See Figures 6-J and 6-K for treatment of the concrete barrier curb at median openings.

B. Telescoping Guide Rail End Terminal (TGRET)

1. A telescoping guide rail end terminal (TGRET) shall be used when terminating dual faced beam guide or dual faced modified thrie beam guide rail within a grass median, see Figure 8-J. The designer is advised to check the Department's MASH Qualified Products List (QPL) for terminals that may be used with dual faced beam guide or dual faced modified thrie beam guide rail.
2. A TGRET shall be installed on relatively flat surfaces (8 percent or flatter slope). Use on raised islands or behind curbs is not recommended. If there is a cross slope of more than 8 percent at the telescoping guide rail end terminal location, a leveling pad must be used.

3. All curbs, islands, or elevated objects (delineators, signs) present at the TGRET site and over 2 inches high should be removed. Curbs greater than 2 inches high should be removed a minimum of 75 feet in front of the telescoping guide rail end terminal system and as far back as the rear of the system, and replaced with 2 inch high curb.
4. The designer should check with the manufacturer to determine where the point of redirection occurs. The length of the TGRET is as per the manufacturer's recommendation, see the MASH QPL. See *Standard Roadway Construction Details CD-609-7 and CD-609-7A*.
5. When terminating the approach end of beam guide rail, or modified thrie beam guide rail shielding bridge piers or sign supports in the median (Figure 8-J), a TGRET may be used. A 31'-3" transition will be required when terminating dual faced modified thrie beam guide rail with a telescoping guide rail end terminal. See *Standard Roadway Construction Detail CD-609-7A*.

C. Beam Guide Rail Anchorage

When terminating the trailing end of dual faced beam guide rail or dual faced modified thrie beam guide rail separating same direction traffic, a beam guide anchorage is required as shown in the *Standard Roadway Construction Details CD-609-4 and CD-609-20*.

8.5 Diversionary Roads (Road Closure with Diversion)

During construction when traffic must be diverted onto the opposing side of a freeway or Interstate highway that is not divided by a barrier curb, the existing guide rail in the median must be revised when the duration of the diversion road will be greater than two weeks. Since traffic will now be traveling in the opposite direction adjacent to the median, existing guide rail lengths may need to be increased. The L.O.N. shall be checked based upon the proposed design speed of the diversionary road and revised if required. See Section 14 for guidance on design speed of diversionary roads. In addition, existing guide rail trailing end treatments shall be upgraded to approach end treatments and bridge attachments Type B shall be converted to Type A. New or reconstructed pylons may be required on some existing bridges to accommodate the Type A attachment.

In addition to the above, when it is anticipated that the diversion road will be in place for 1.5 years or more, new guide rail in the median shall be lapped in the direction of traffic and existing guide rail in the median shall be re-lapped in the direction of traffic. Also, a clear runout area shall be provided behind new approach flared or tangent terminals in the median.

After the diversionary road is no longer required, the guide rail in the median shall be re-lapped in the direction of traffic if the diversion road has been in place for more than 1.5 years. Furthermore, any additional lengths of guide rail installed in the median due to the diversion should be removed and appropriate end terminals added. However, bridge attachments that were converted to Type A may be retained when the guide rail on the trailing end of the bridge parapet is to remain.

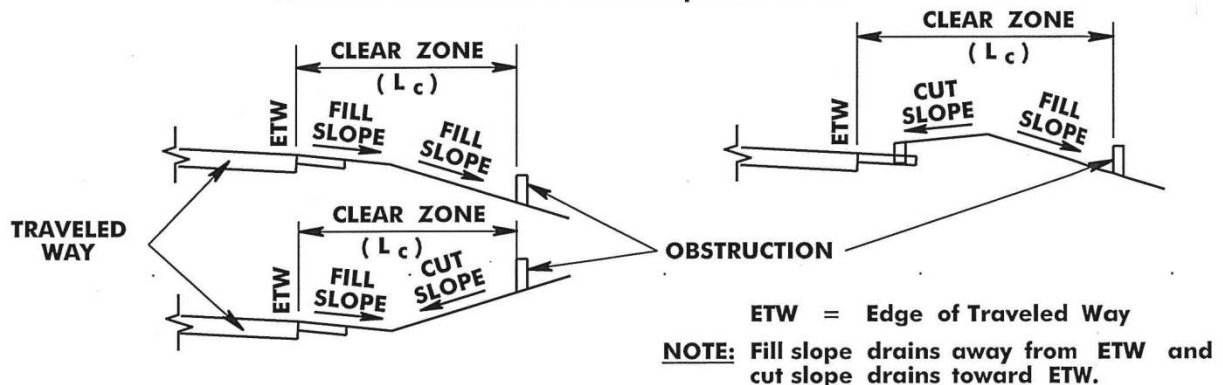
The above requirements also apply to land service highways with grass medians or those separated by development between the opposing roadways when a diversionary road is required.

FIGURE 8-A: CLEAR ZONE (L_c)

The following table contains the suggested range of clear zone distances on tangent sections of roadway based on selected traffic volumes, speed and roadside slopes:

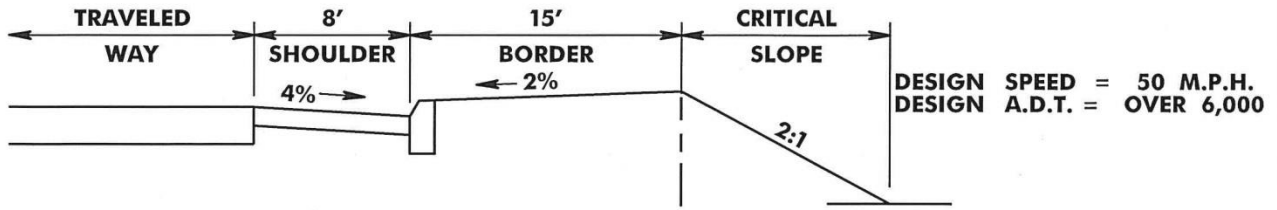
DESIGN SPEED	DESIGN ADT	CLEAR ZONE DISTANCES (IN FEET FROM EDGE OF THROUGH LANE)				
		FILL SLOPES*		CUT SLOPES		
		6: 1 OR FLATTER	5: 1 TO 4:1	3: 1 OR STEEPER	4: 1 TO 5:1	6: 1 OR FLATTER
40 MPH OR LESS	UNDER 750	7-10	7-10	7-10	7-10	7-10
	750-1,500	10-12	12-14	10-12	10-12	10-12
	1,500-6,000	12-14	14-16	12-14	12-14	12-14
	OVER 6,000	14-16	16-18	14-16	14-16	14-16
45 - 50 MPH	UNDER 750	10-12	12-14	8-10	8-10	10-12
	750-1,500	14-16	16-20	10-12	12-14	14-16
	1,500-6,000	16-18	20-26	12-14	14-16	16-18
	OVER 6,000	20-22	24-28	14-16	18-20	20-22
55 MPH	UNDER 750	12-14	14-18	8-10	10-12	10-12
	750-1,500	16-18	20-24	10-12	14-16	16-18
	1,500-6,000	20-22	24-30	14-16	16-18	20-22
	OVER 6,000	22-24	26-32	16-18	20-22	22-24
60 MPH	UNDER 750	16-18	20-24	10-12	12-14	14-16
	750-1,500	20-24	26-32	12-14	16-18	20-22
	1,500-6,000	26-30	32-40	14-18	18-22	24-26
	OVER 6,000	30-32	36-44	20-22	24-26	26-28
65 - 70 MPH	UNDER 750	18-20	20-26	10-12	14-16	14-16
	750-1,500	24-26	28-36	12-16	18-20	20-22
	1,500-6,000	28-32	34-42	16-20	22-24	26-28
	OVER 6,000	30-34	38-46	22-24	26-30	28-30

* See RDM Section 8.2.4 for fill slopes 3:1 to 4:1



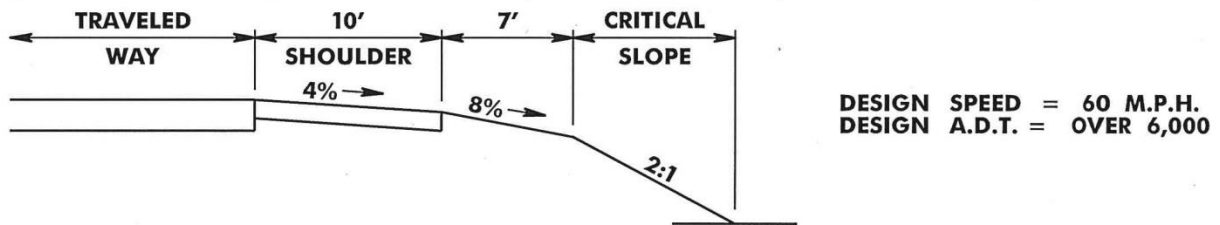
SOURCE: "Chapter 3: Roadside Topography and Drainage Features."
Roadside Design Guide, 4th Edition, AASHTO, 2011 and
Errata Sheet Dated July 2015

FIGURE 8-B1: CLEAR ZONE EXAMPLES



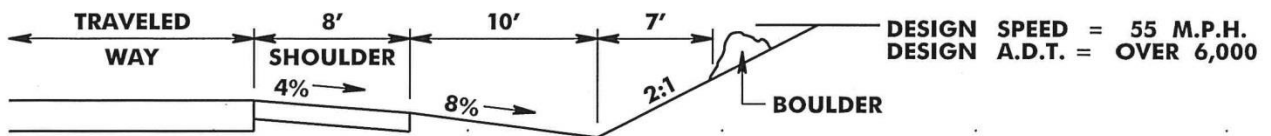
The suggested clear zone distance for the 2% slope (See Figure 8-A, Cut Slope, 6:1 or flatter) = 20-22 feet.

The available 23 feet is 1 to 3 feet greater than the suggested recovery area, therefore, the critical slope (2:1) is outside the clear zone.



The suggested clear zone distance for the 8% slope (See Figure 8-A, Fill Slope, 6:1 or flatter) = 30-32 feet.

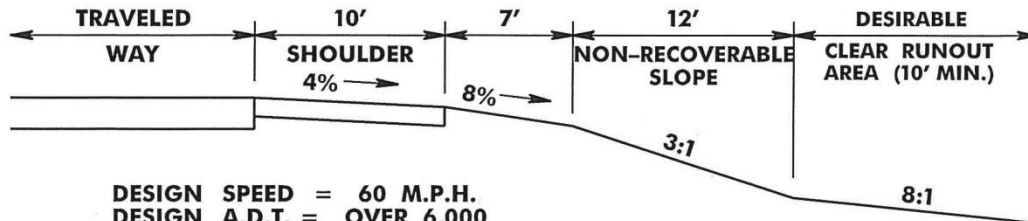
The available 17 feet is 13 to 15 feet less than the suggested recovery area, therefore, the critical slope (2:1) is inside the clear zone.



The suggested clear zone distance for the 8% slope (See Figure 8-A, Fill Slope, 6:1 or flatter) = 22-24 feet. The available 18 feet to the channel is 4 to 6 feet less than the suggested recovery area for the fill slope. The channel is not within the preferred cross section area of Figure 8-U, but to the boulder there is 25 feet available, which is 1 to 3 feet outside the clear zone for the fill slope. Since the channel bottom and backslope are free of obstructions within the clear zone, guide rail is not required.

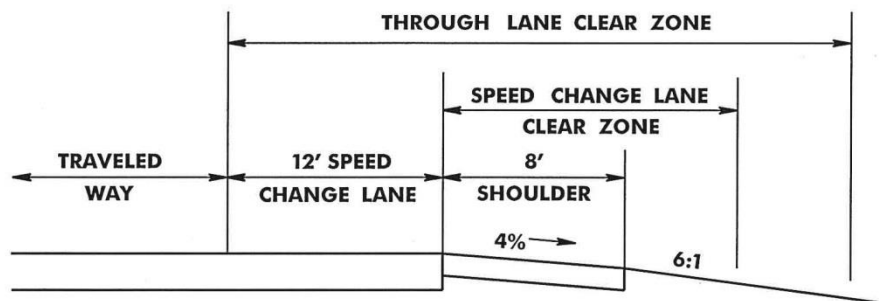
MAY 2017

FIGURE 8-B2: CLEAR ZONE EXAMPLES



DESIGN SPEED = 60 M.P.H.
DESIGN A.D.T. = OVER 6,000

The suggested clear zone distance for the 8:1 slope in the clear runout area (See Figure 8-A, Fill Slope 6:1 or flatter) = 30-32 feet. The recovery distance before breakpoint of non-recoverable slope = 17 feet. Therefore the desirable clear runout area is : 30-32 feet minus 17 feet = 13 to 15 feet. If the calculated clear runout area is less than 10', a minimum 10' clear runout area should be provided.



DESIGN SPEED = 60 M.P.H. (THROUGH LANE),
45 M.P.H. (SPEED CHANGE LANE)
DESIGN A.D.T. = OVER 6,000 (THROUGH LANE)
LESS THAN 750 (SPEED CHANGE LANE)

The suggested clear zone distance for the 6:1 slope (See Figure 8-A, Fill Slope, 6:1 or flatter) = 30-32 feet for the through lane and 10-12 feet for the speed change lane. Measured from the through lane, the speed change lane total is 22-24 feet (10-12 feet plus the 12' speed change lane width). The design clear zone is the greater of the two clear zones (in this case, 30-32 feet). Design speeds for speed change lanes are obtained from Figure 6-H.

MAY 2017

FIGURE 8-C: HORIZONTAL CURVE ADJUSTMENTS FOR CLEAR ZONE

The clear zone widths obtained from Figure 8-A should be increased on the outside of curves. The amount of increase can be determined by the following table:

RADIUS (Ft.)	K _{cz} (CURVE CORRECTION FACTOR)						
	DESIGN SPEED, MPH						
	40	45	50	55	60	65	70
2,950	1.1	1.1	1.1	1.2	1.2	1.2	1.2
2,300	1.1	1.1	1.2	1.2	1.2	1.2	1.3
1,970	1.1	1.2	1.2	1.2	1.3	1.3	1.4
1,640	1.1	1.2	1.2	1.3	1.3	1.3	1.4
1,475	1.2	1.2	1.3	1.3	1.4	1.4	1.5
1,315	1.2	1.2	1.3	1.3	1.4	1.4	
1,150	1.2	1.2	1.3	1.4	1.5	1.5	
985	1.2	1.3	1.4	1.5	1.5	1.5	
820	1.3	1.3	1.4	1.5			
660	1.3	1.4	1.5				
495	1.4	1.5					
330	1.5						

$$CZ_c = (L_c) (K_{cz})$$

CZ_c = CLEAR ZONE ON OUTSIDE OF HORIZONTAL CURVE, FEET.

L_c = CLEAR ZONE DISTANCE FROM FIGURE 8-A, FEET.

K_{cz} = CURVE CORRECTION FACTOR.

NOTE:

Clear zone correction factor is applied to outside of horizontal curves only. Curves flatter than 2,950 ft. do not require an adjusted clear zone. Also, adjustments are not necessary for design speeds less than 40 MPH.

SOURCE: "Chapter 3: Roadside Topography and Drainage Features."
Roadside Design Guide, 4th Edition, AASHTO, 2011

MAY 2017

FIGURE 8-D: ROADSIDE RECOVERY AREA AT FLARED AND TANGENT TERMINALS

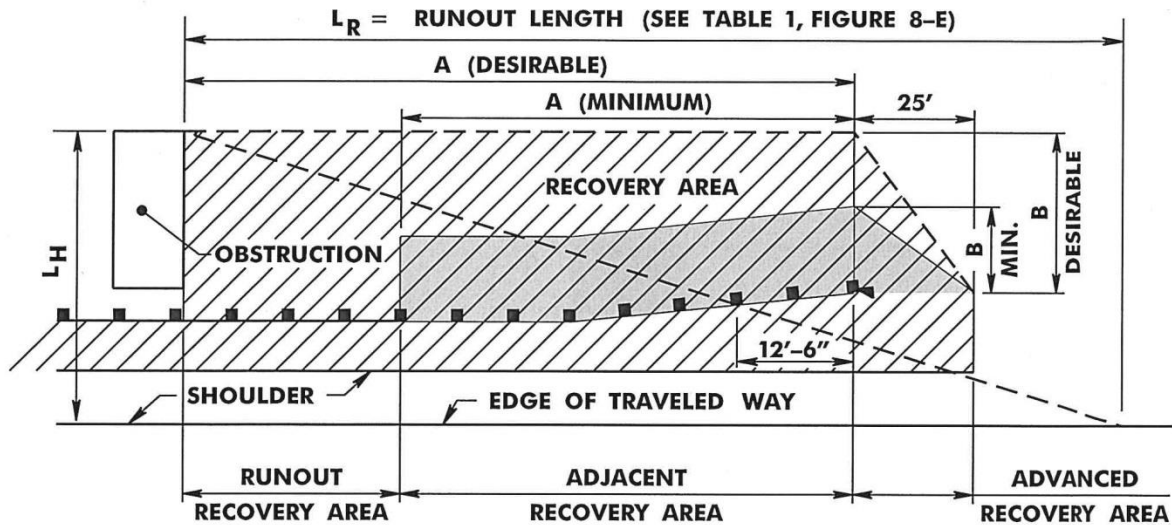


TABLE 1		
MINIMUM ADJACENT RECOVERY AREA BEHIND GUIDE RAIL (SHADED AREA)		
Design Speed (mph)	A (ft.)	B (ft.) See Note C
40 or less	50	10
45	55	12
50	60	15
55	65	18
60 or greater	75	20

NOTES

- A. No fixed objects should be within the crosshatched area. Desirably, dimension (A) should equal the L.O.N. plus 12'-6", and dimension (B) should extend from the face of the terminal to the offset L_H (See Note B). When it is not practical to provide a roadside recovery area behind the guide rail based on the desirable dimensions, the minimum adjacent recovery area dimensions in Table 1 may be used along with the advanced recovery area.
- B. If dimension (B) extends the area to be cleared beyond the R.O.W. line or L_H , the roadside recovery area should extend to the R.O.W. line when L_H is outside of the R.O.W. line, and no further than L_H when L_H is within the R.O.W. line.
- C. If the typical lateral roadside recovery area in advance of the terminal is smaller than shown in Table 1, a lesser value for dimension (B) may be used but it should be consistent with that available elsewhere along the roadway.
- D. See RDM Section 8.2.4.B.2 for discussion on utility placement.

MAY 2017

FIGURE 8-E: APPROACH LENGTH OF NEED ON EMBANKMENT (FILL) SLOPE

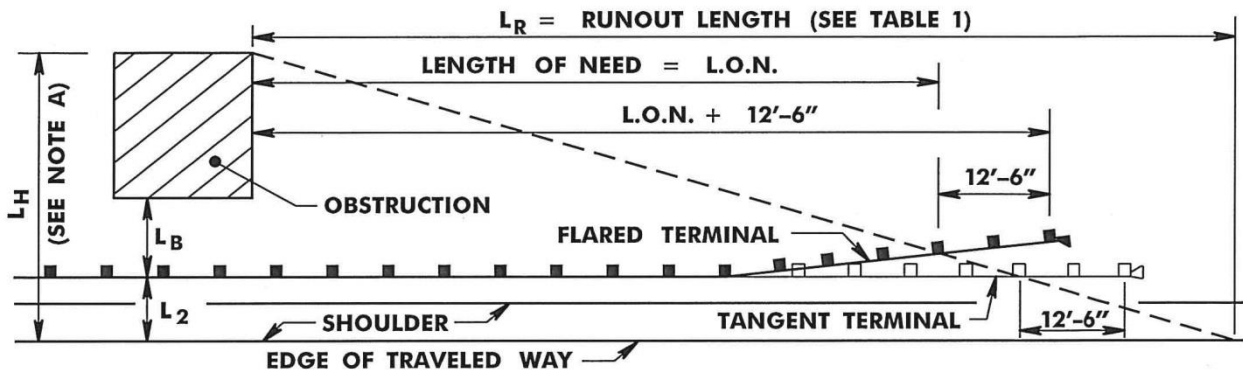


TABLE 1						
DESIGN SPEED (M.P.H.)	TRAFFIC VOLUME (A.D.T.)				SHY LINE OFFSET (FEET)	STRAIGHT FLARE RATE
	OVER 10,000	5,000 TO 10,000	1,000 TO 5,000	UNDER 1,000		
	L_R	L_R	L_R	L_R		
70	360	330	290	250	9	15:1
60	300	250	210	200	8	14:1
55	265	220	185	175	7	12:1
50	230	190	160	150	6.5	11:1
45	195	160	135	125	6	10:1
40	160	130	110	100	5	8:1
30	110	90	80	70	4	7:1

STEP 1. Determine the required L.O.N. for:

FLARED TERMINAL

$$L.O.N. = \frac{L_R (L_H - L_2 - 2.7)}{L_H}$$

TANGENT TERMINAL

$$L.O.N. = \frac{L_R (L_H - L_2)}{L_H}$$

NOTE A. If the obstruction extends beyond the clear zone, make L_H equal to the clear zone, except if the obstruction is a critical slope, See Figure 8-H.

NOTE B. If the roadway is curved, draw the layout to scale and obtain L.O.N. directly by scaling from the drawing.

STEP 2. Increase the L.O.N. to the nearest multiple of 12'-6" (length of one rail element).

STEP 3. Add an additional 12'-6" to get the required length from the obstruction to the approach end of the flared or tangent terminal.

STEP 4. Compare the required length from Step 3 to the minimum length in Table 2 and to the minimum recovery area length from Figure 8-D, Table 1. Use the greater of the three lengths.

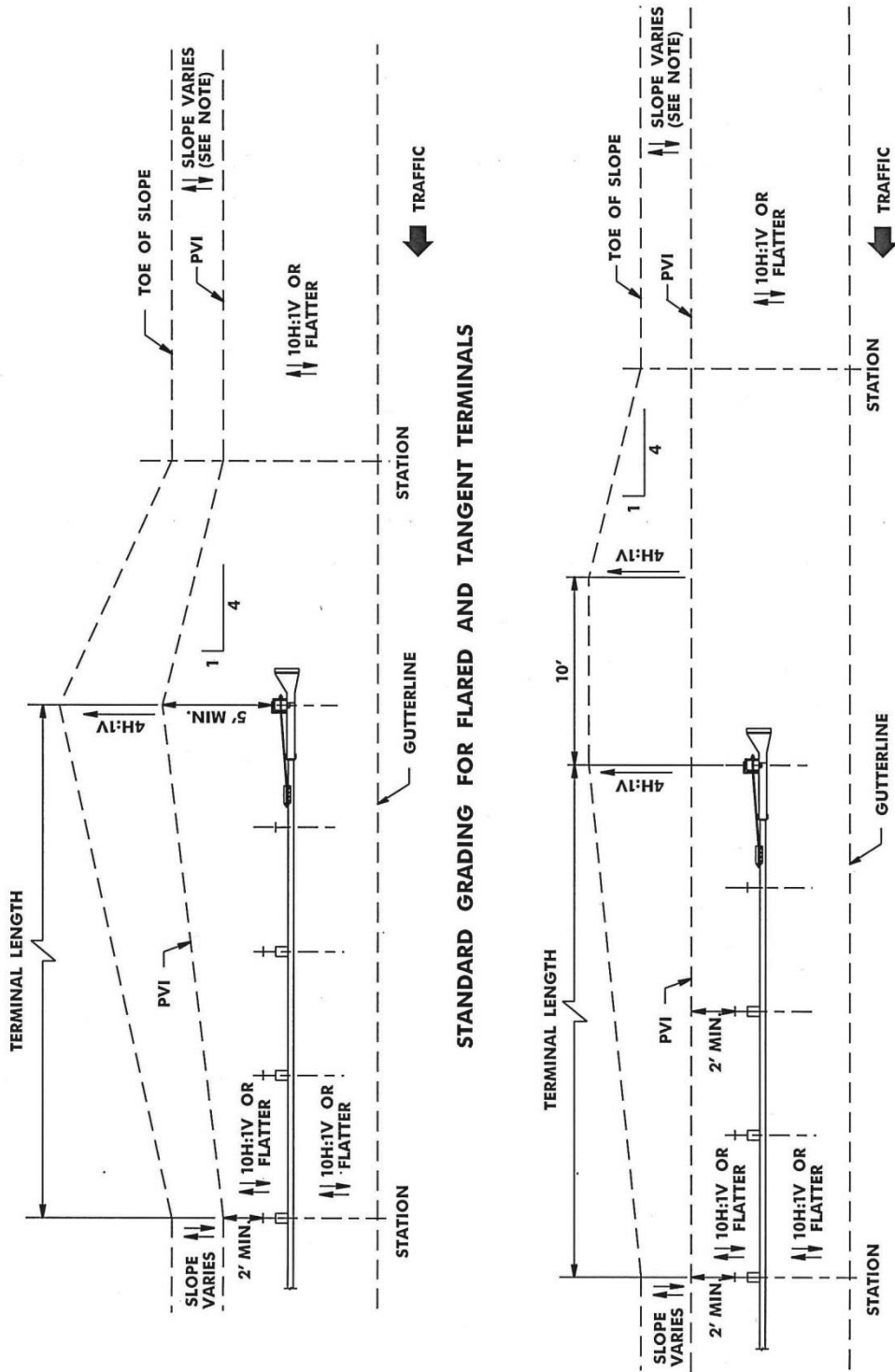
TABLE 2		
DISTANCE FROM FACE OF RAIL ELEMENT TO OBSTRUCTION (L_B)	MINIMUM LENGTH BASED ON POST SPACING (NOTE C)	
	FLARED TERMINAL	TANGENT TERMINAL
$L_B \geq 4'$	43'-9"	50'-0"
$2.5' \leq L_B < 4'$	75'-0"	62'-6"
$1.5' \leq L_B < 2.5'$	81'-3"	68'-9"

NOTE C: Minimum distance from the obstruction to the approach end of terminal for standard and reduced post spacing. See CD-609-8.1.

NOTE D: The total length of a freestanding guide rail installation including the approach and trailing end treatments should not be less than 75'. See Figure 8-02 for min. approach guide rail transition lengths.

MAY 2017

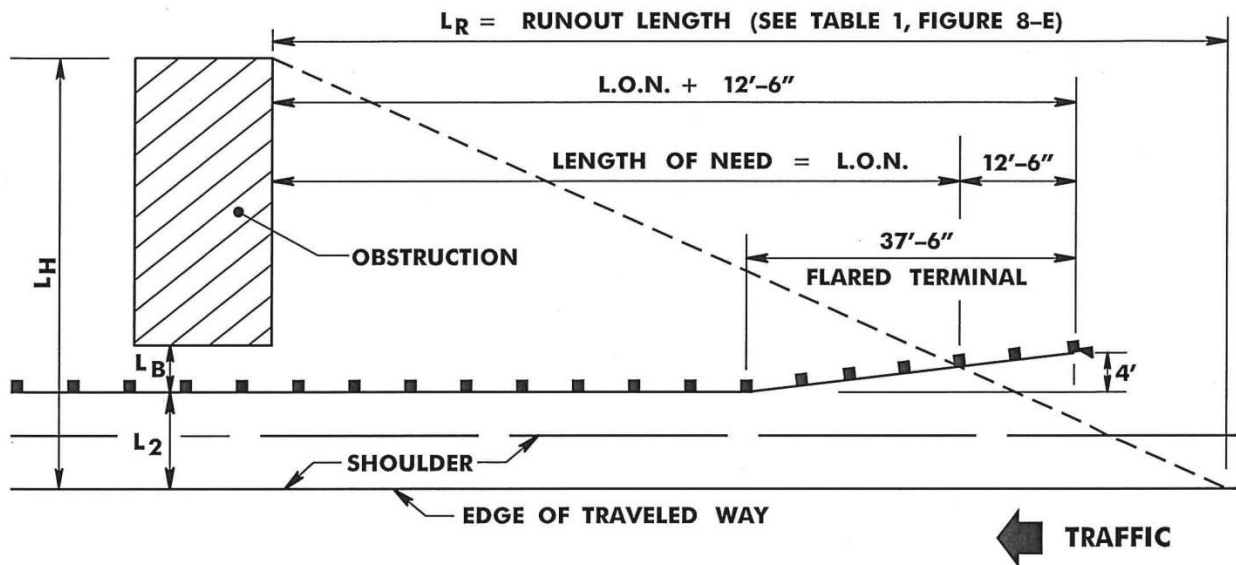
FIGURE 8-F: GRADING TREATMENT AT FLARED AND TANGENT TERMINALS



ALTERNATE GRADING FOR TANGENT TERMINALS ONLY

NOTE:
Grading only needed if approaching slope is steeper than 4H:1V

**FIGURE 8-G:
EXAMPLE OF APPROACH LENGTH OF NEED ON
EMBANKMENT (FILL) SLOPES**



EXAMPLE

DESIGN SPEED = 70 MPH

TANGENT ROADWAY

A.D.T. = 7000

$L_B = 4'$

$L_H = 22'$

$L_R = 330'$

$L_2 = 16'$

STEP 1.
$$L.O.N. = \frac{L_R (L_H - L_2 - 2.7')}{L_H}$$

$$L.O.N. = \frac{330' (22' - 16' - 2.7')}{22'}$$

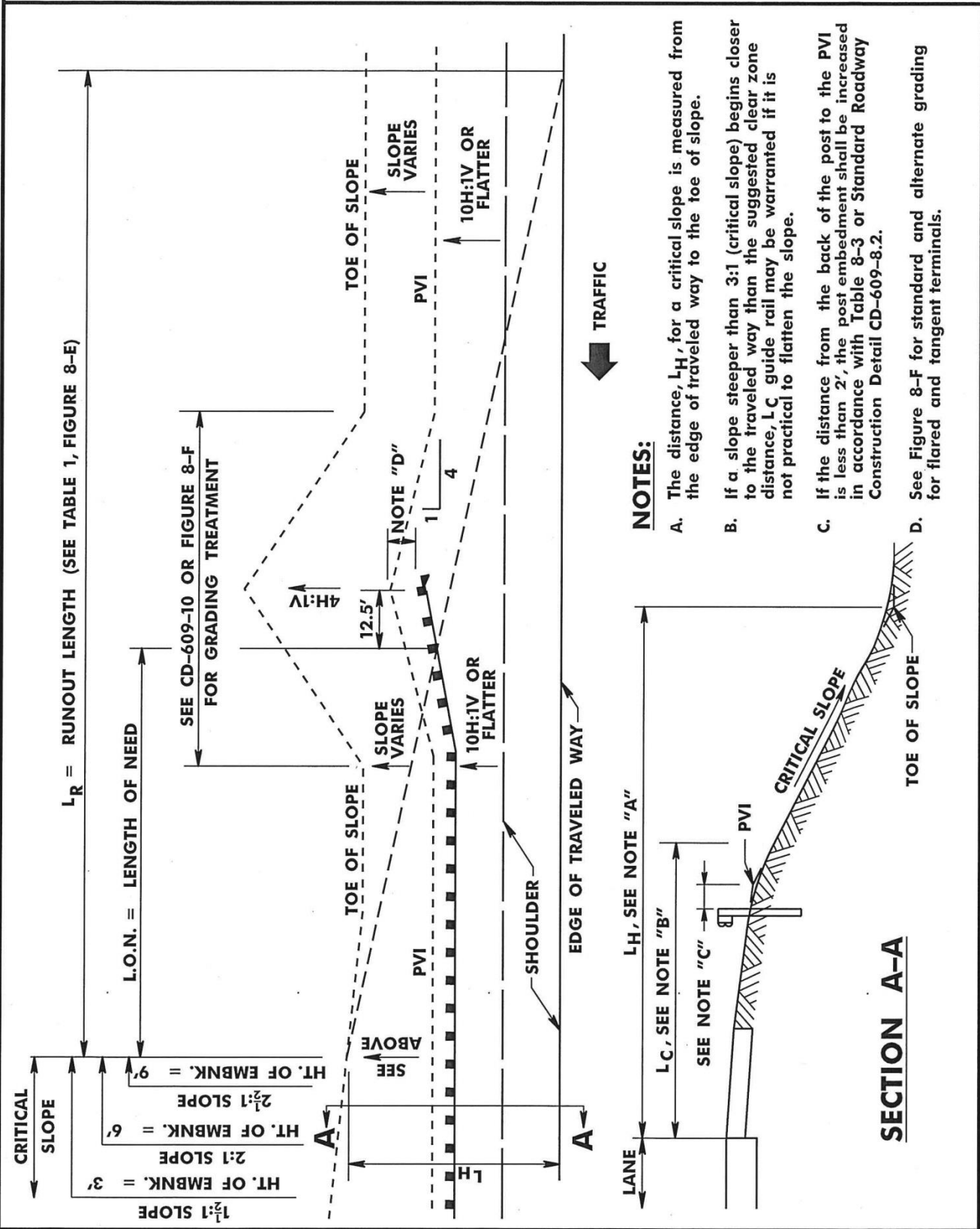
$L.O.N. = 49.5'$

STEP 2. Increase 49.5' to nearest multiple of 12'-6", L.O.N. = 50'.

STEP 3. Add an additional 12'-6" to get required L.O.N. including the terminal, use $L.O.N. + 12.5' = 62.5'$.

STEP 4. From Figure 8-D, the minimum recovery area length is 75'. Since $L.O.N. + 12.5'$ is less than 75', use 75'.

**FIGURE 8-H:
GUIDE RAIL TREATMENT FOR CRITICAL EMBANKMENT SLOPES**



NOTES:

- A. The distance, L_H , for a critical slope is measured from the edge of traveled way to the toe of slope.
- B. If a slope steeper than 3:1 (critical slope) begins closer to the traveled way than the suggested clear zone distance, LC guide rail may be warranted if it is not practical to flatten the slope.
- C. If the distance from the back of the post to the PVI is less than 2', the post embedment shall be increased in accordance with Table 8-3 or Standard Roadway Construction Detail CD-609-8.2.
- D. See Figure 8-F for standard and alternate grading for flared and tangent terminals.

SECTION A-A

MAY 2017

FIGURE 8-1: APPROACH LENGTH OF NEED FOR OPPOSING TRAFFIC ON EMBANKMENT (FILL) SLOPES

CONDITION 1. $L_2 > L_C$:

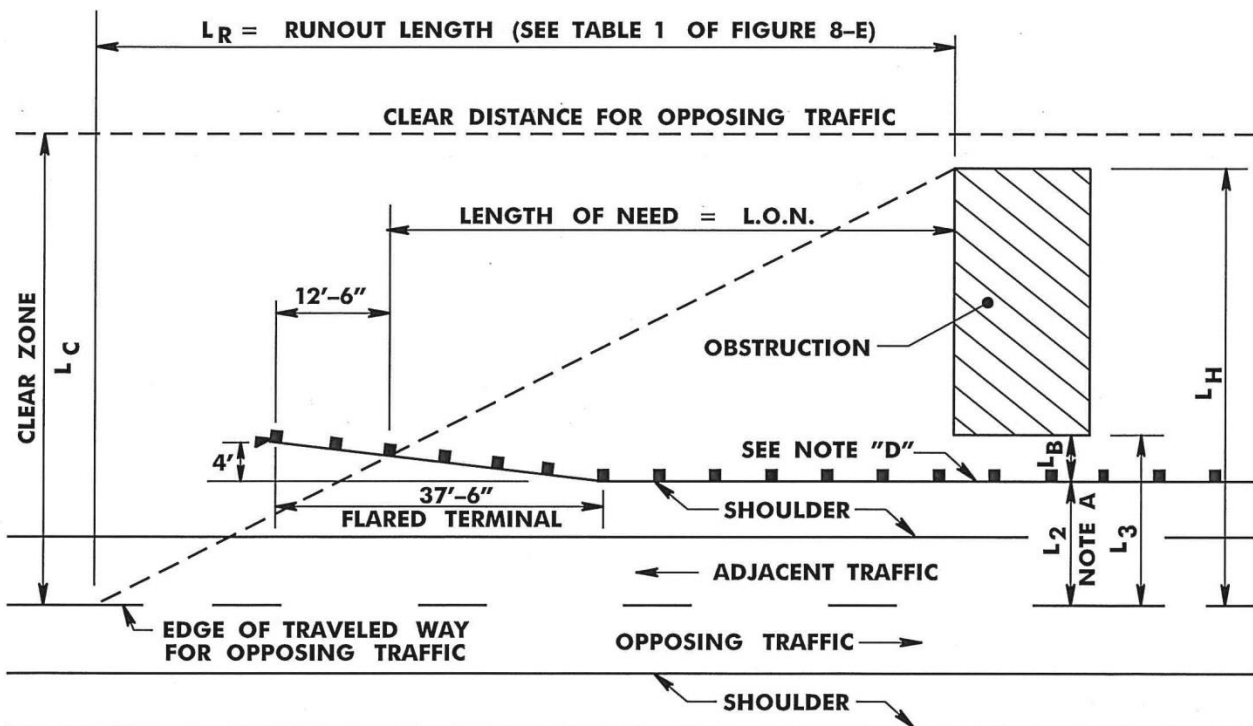
If guide rail is outside the clear zone (L_C), no additional guide rail or approach end treatment is required. Use beam guide rail anchorage as shown in Figure 8-12 and the Standard Roadway Construction Details.

CONDITION 2. $L_2 < L_C$ and $L_3 > L_C$:

If guide rail is within the clear zone, but the obstruction is beyond it, use a flared or tangent terminal with the minimum recovery length (A) shown in Table 1, Figure 8-D.

CONDITION 3. $L_3 < L_C$:

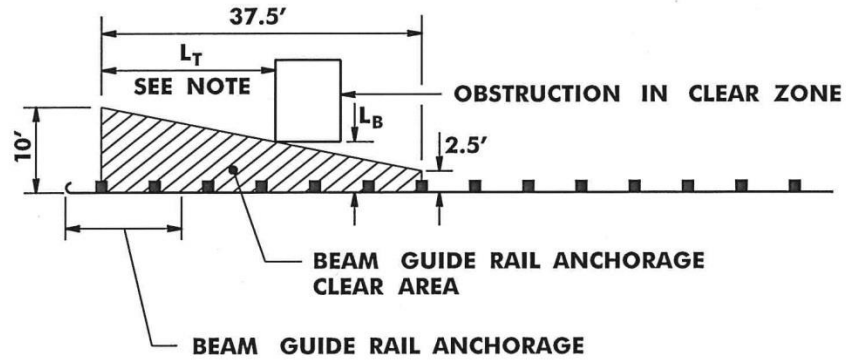
If the obstruction is within the clear zone (L_C), see below. Use variables as shown below and Steps 1 through 4 as shown in Figure 8-E to determine the required L.O.N.



- NOTES:**
- L_2 shall be measured from the outside edge of the approaching traffic lane where passing is permitted.
 - If there is a traversable median separating traffic, the median width should be included when determining L_2 , L_3 , and L_H for opposing traffic.
 - For a divided highway with a nontraversable median, use a beam guide rail anchorage as shown in Figure 8-12 and the Standard Roadway Construction Details.
 - Where the distance from the obstruction to the face of the rail element (L_B) is less than 4', See Standard Roadway Construction Detail CD-609-8 for post spacing requirements. Under Condition 2 & 3 above, the post spacing requirements apply to both the approach and the trailing end.

MAY 2017

FIGURE 8-12: BEAM GUIDE RAIL ANCHORAGE CLEAR AREA



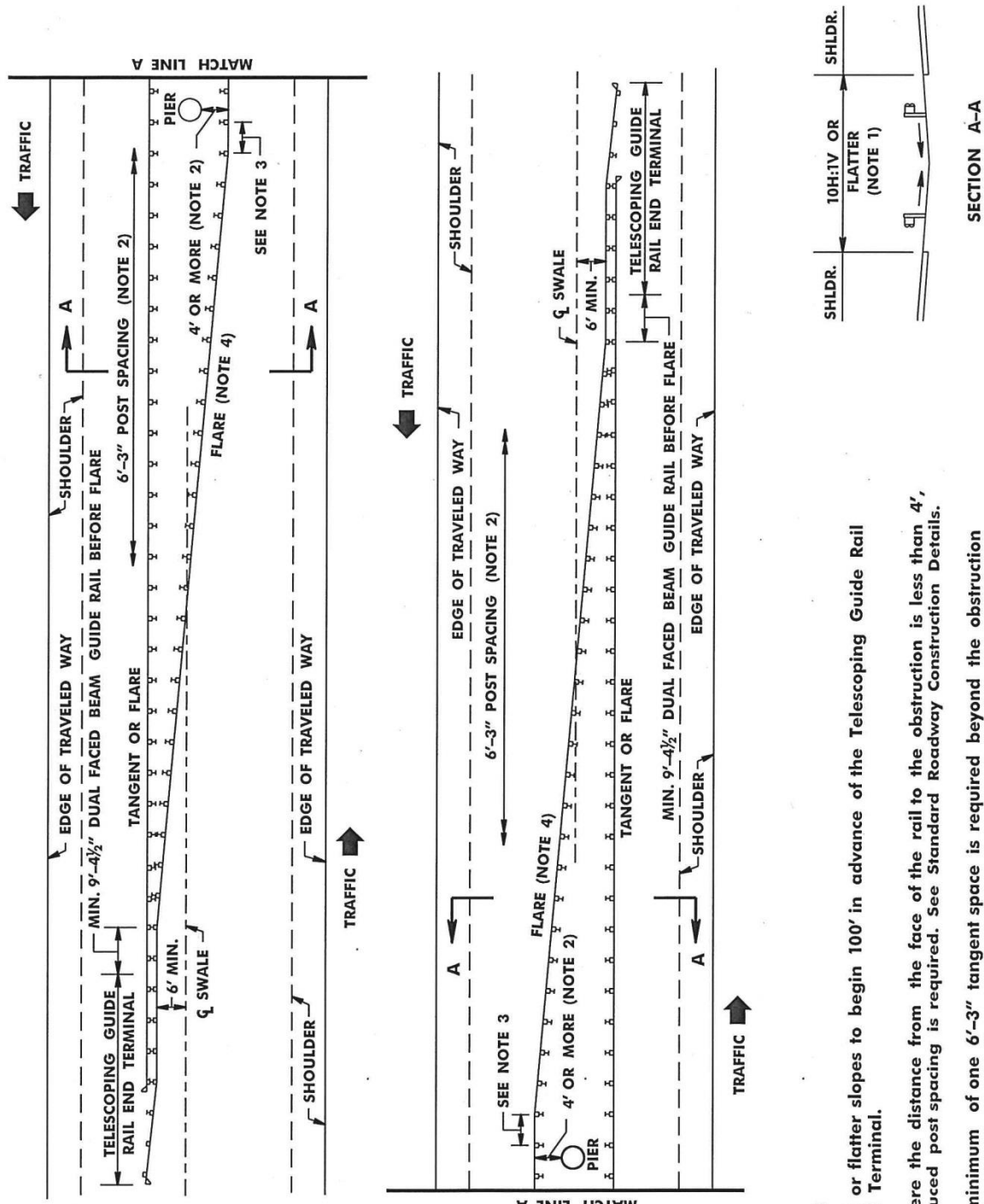
NOTE:

Where a beam guide rail anchorage is used to terminate guide rail past an obstruction, the guide rail should be extended so that the obstruction is outside of the anchorage clear area. The distance from the last post of the beam guide rail anchorage to the obstruction shall not be less than 12'-6". See Table 1.

TABLE 1	
DISTANCE FROM FACE OF RAIL TO OBSTRUCTION (L_B) *	MINIMUM DISTANCE FROM LAST POST OF ANCHORAGE TO THE OBSTRUCTION (L_T)
2.5' OR LESS	37.5'
3'	35'
4'	30'
5'	25'
6'	20'
7'	15'
7.5' OR GREATER	12.5'

* Where clearance from the face of rail to the obstruction is less than 4', reduced post spacing is required. See Standard Roadway Construction Details.

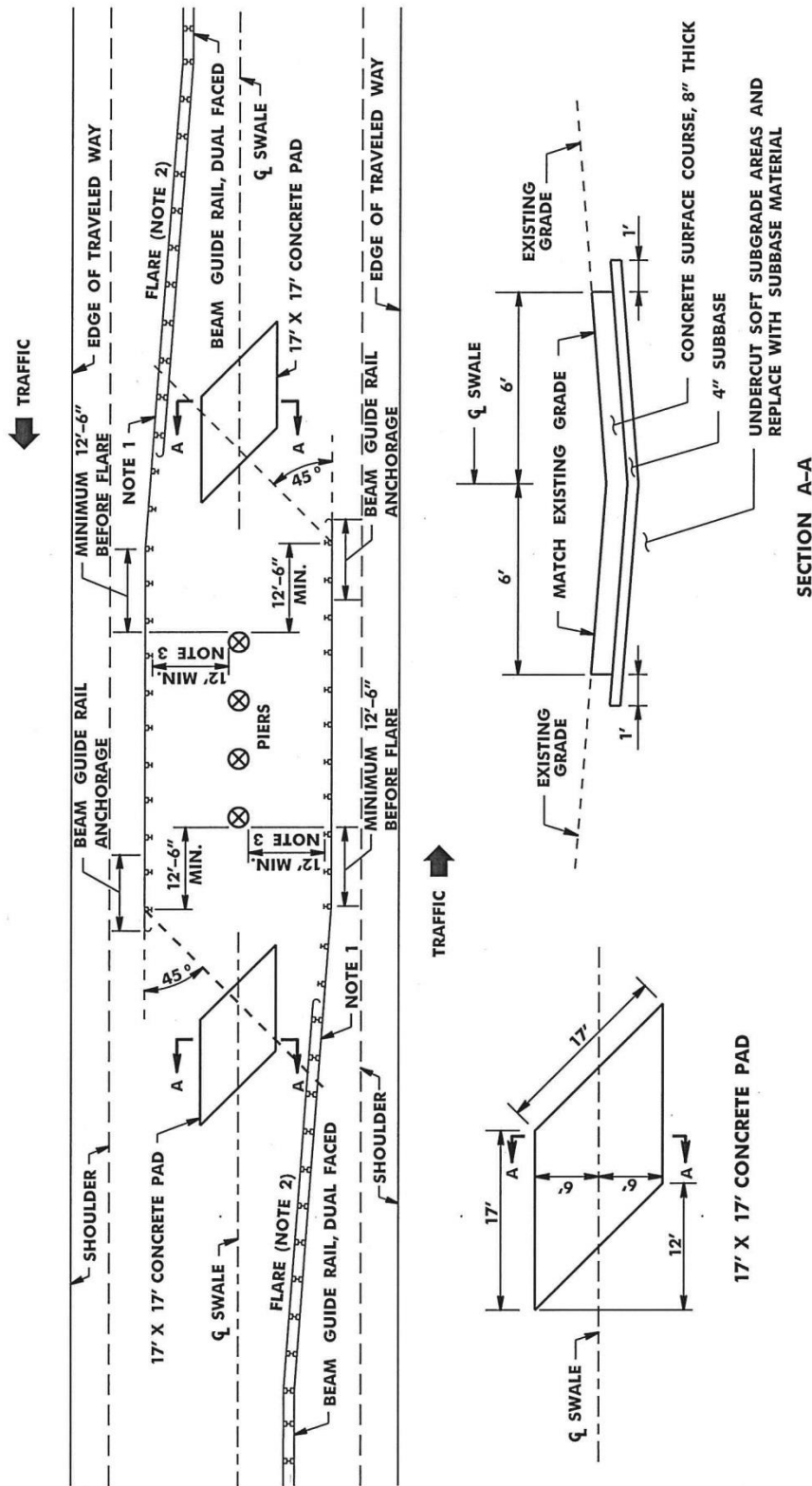
FIGURE 8-J: TELESCOPING GUIDE RAIL END TERMINAL IN MEDIAN



- NOTES:**
1. 10:1 or flatter slopes to begin 100' in advance of the Telescoping Guide Rail End Terminal.
 2. Where the distance from the face of the rail to the obstruction is less than 4', reduced post spacing is required. See Standard Roadway Construction Details.
 3. A minimum of one 6'-3" tangent space is required beyond the obstruction before beginning a flare.
 4. See Figure 8-E, Table 1 for maximum flare rate.

MAY 2017

**FIGURE 8-K:
OVERLAPPING MEDIAN GUIDE RAIL WITH
CONCRETE PAD FOR MAINTENANCE VEHICLE U-TURN**

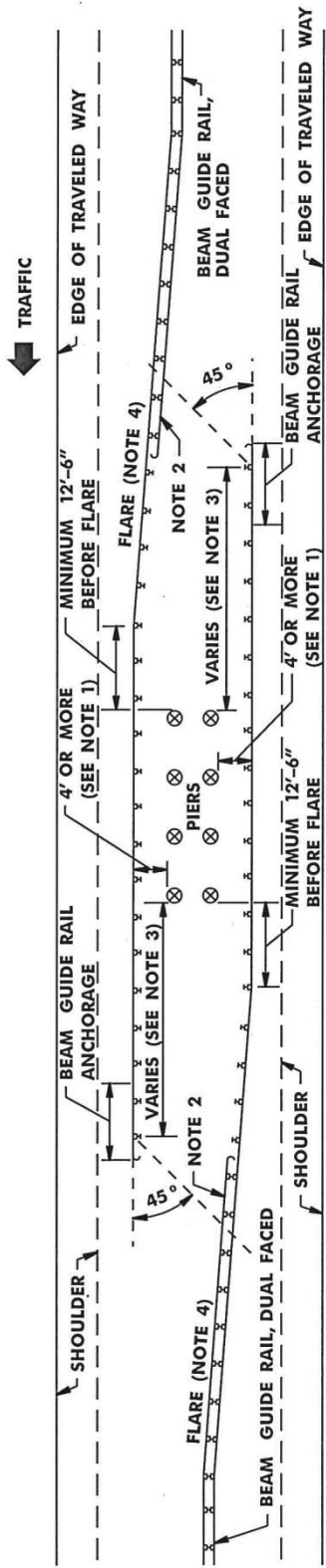


NOTES:

1. Extend dual faced guide rail a minimum of one 6'-3" space (two posts) beyond a 45 degree line extending from the last post of the beam guide rail anchorage.
2. See Figure 8-E, Table 1, for maximum flare rate.
3. A 12' minimum offset from back of guide rail post to face of pier is required for operational U-turns.
4. Use an SU turn template to locate concrete pad on swale.
5. Locate concrete pad on plan by station.

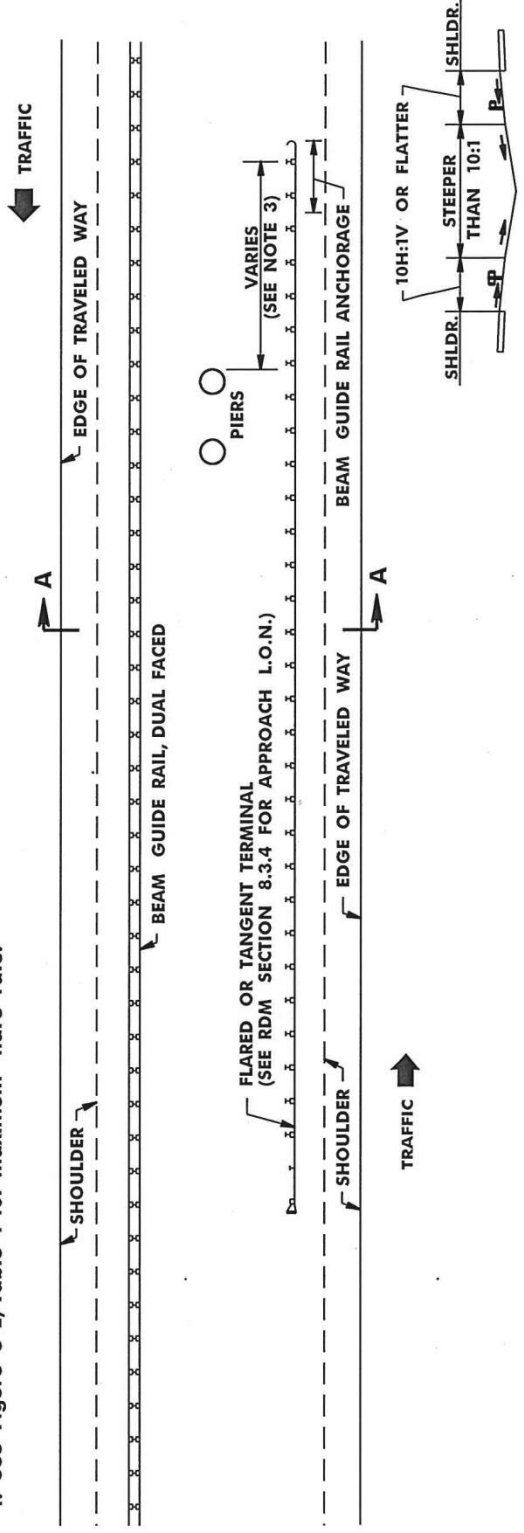
MAY 2017

FIGURE 8-L: DUAL FACED MEDIAN GUIDE RAIL TREATMENTS



OVERLAPPING DUAL FACED MEDIAN BEAM GUIDE RAIL

- NOTES:**
1. Where clearance from the face of rail to the obstruction is less than 4', reduced post spacing is required. See Standard Roadway Construction Details.
 2. Extend dual faced guide rail a minimum of one 6'-3" space (two posts) beyond a 45 degree line extended from the last post of the beam guide rail anchorage.
 3. See Figure 8-1-2 for the minimum distance from the last post of the beam guide rail anchorage to the obstruction.
 4. See Figure 8-E, Table 1 for maximum flare rate.



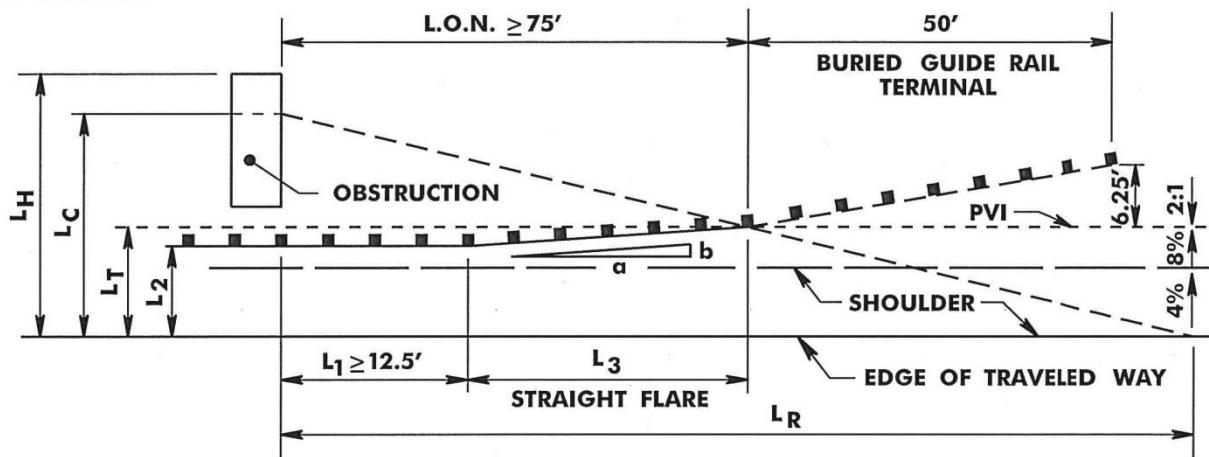
DUAL FACED MEDIAN GUIDE RAIL AND TANGENT OR FLARED TERMINAL

MAY 2017

FIGURE 8-M: APPROACH LENGTH OF NEED FOR BURIED GUIDE RAIL TERMINAL

Where an obstruction is encountered in a cut section and it is to be shielded with a buried guide rail terminal, it is desirable that the length of need (L.O.N.) end at the PVI (See Figure 8-N for additional details). In order to accomplish this, the length of guide rail parallel to the PVI (L_1) must be obtained. The following example shows how the L.O.N. is computed:

EXAMPLE



$$V = 60 \text{ MPH}$$

$$\text{A.D.T.} = 6,000$$

$$L_2 = 16'$$

$$L_H = 32'$$

$$L_R = 250' \text{ (from Figure 8-E, Table 1)}$$

$$L_T = 19'$$

$$\frac{a}{b} = 14:1 \text{ straight flare (from Figure 8-E, Table 1)}$$

$$L_C = 30' \text{ (from Figure 8-A, } L_C = 26' - 30' \text{) for } 8\% \text{ fill slope}$$

If $L_H > L_C$ use L_C in formula below, If $L_H < L_C$, replace L_C with L_H in formula below

$$L_1 = L_R - \frac{L_R L_T}{L_C} - \frac{a}{b} (L_T - L_2)$$

$$L_1 = 250 - \frac{250 \times 19}{30} - \frac{14}{1} (19 - 16) = 49.7'$$

$$49.7' / 6.25' \text{ post spacing} = 7.95 \text{ posts, therefore, use } 8 \text{ posts at } 6.25' = 50' = L_1$$

$$\text{Flare length } L_3 = \frac{a}{b} (L_T - L_2) = \frac{14}{1} (19 - 16) = 42'$$

$$42' / 6.25' \text{ post spacing} = 6.72 \text{ posts, therefore, use } 7 \text{ posts at } 6.25' = 43.75' = L_3$$

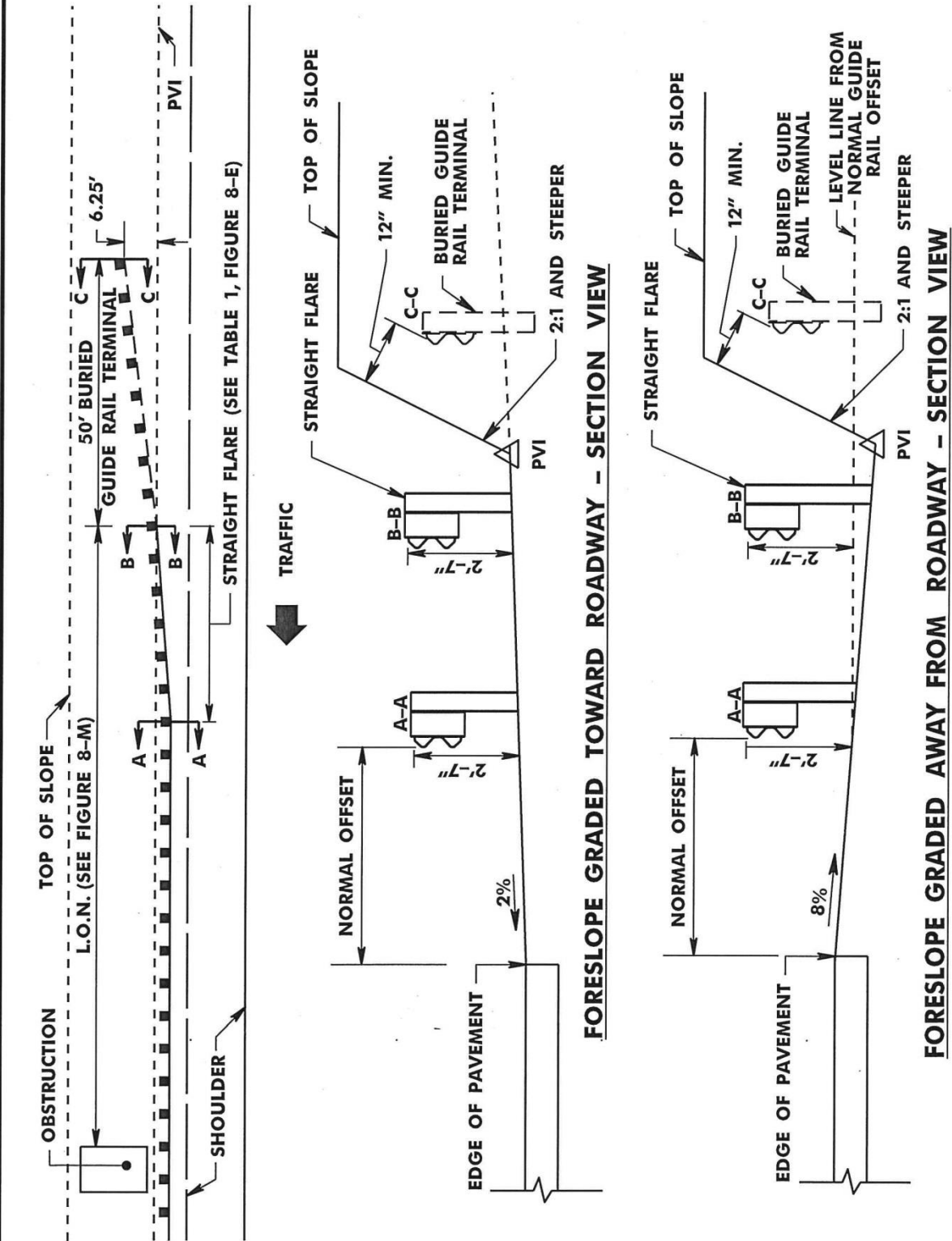
$$\text{L.O.N.} = L_1 + L_3 = 50' + 43.75' = 93.75'$$

The minimum L.O.N. as shown in the Figure above = 75'.

Since L.O.N. is greater than 75', use L.O.N. = 93.75'

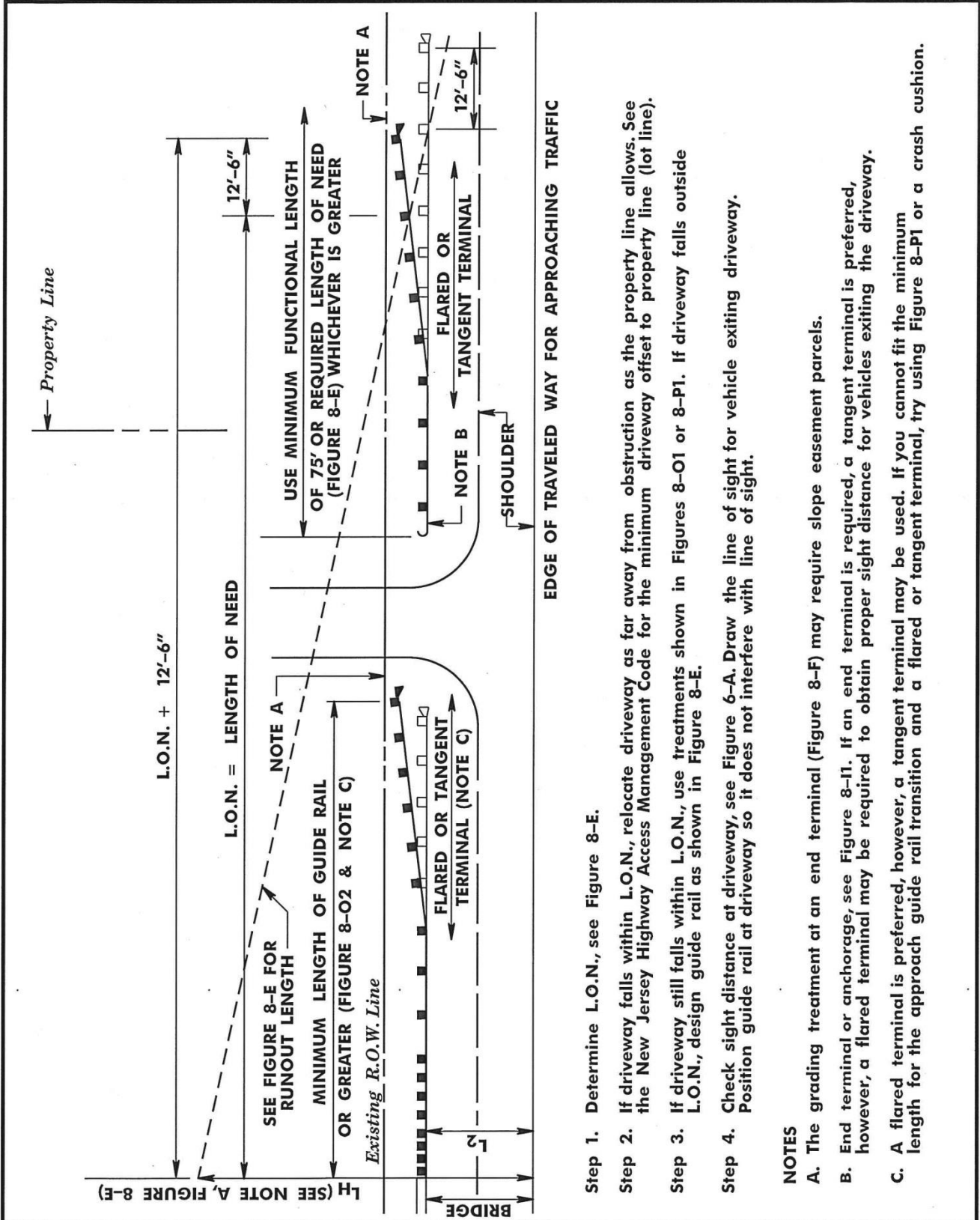
MAY 2017

**FIGURE 8-N:
BEAM GUIDE RAIL TREATMENT FOR
BURIED GUIDE RAIL TERMINAL**



MAY 2017

**FIGURE 8-01:
EXAMPLE OF GUIDE RAIL TREATMENT AT DRIVEWAY
LOCATED WITHIN LENGTH OF NEED**



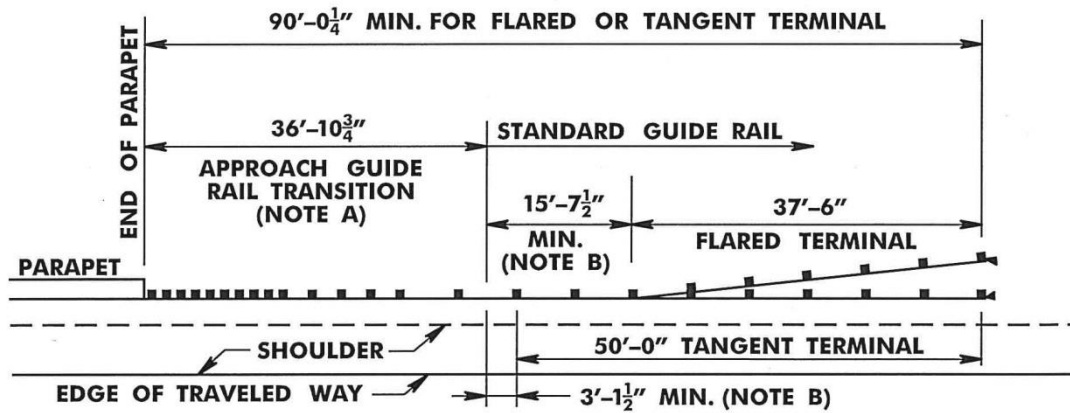
- Step 1. Determine L.O.N., see Figure 8-E.
- Step 2. If driveway falls within L.O.N., relocate driveway as far away from obstruction as the property line allows. See the New Jersey Highway Access Management Code for the minimum driveway offset to property line (lot line).
- Step 3. If driveway still falls within L.O.N., use treatments shown in Figures 8-01 or 8-P1. If driveway falls outside L.O.N., design guide rail as shown in Figure 8-E.
- Step 4. Check sight distance at driveway, see Figure 6-A. Draw the line of sight for vehicle exiting driveway. Position guide rail at driveway so it does not interfere with line of sight.

NOTES

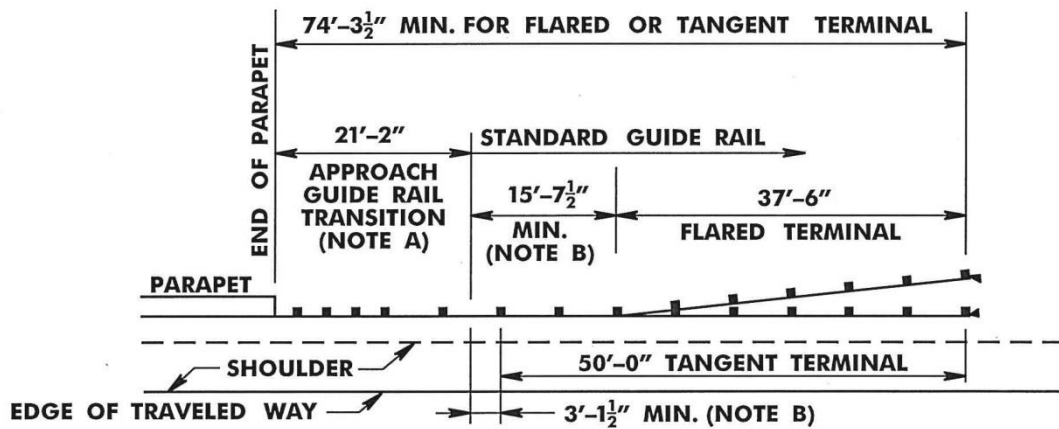
- A. The grading treatment at an end terminal (Figure 8-F) may require slope easement parcels.
- B. End terminal or anchorage, see Figure 8-11. If an end terminal is required, a tangent terminal is preferred, however, a flared terminal may be required to obtain proper sight distance for vehicles exiting the driveway.
- C. A flared terminal is preferred, however, a tangent terminal may be used. If you cannot fit the minimum length for the approach guide rail transition and a flared or tangent terminal, try using Figure 8-P1 or a crash cushion.

MAY 2017

**FIGURE 8-02:
APPROACH GUIDE RAIL TRANSITION
MINIMUM LENGTH OF GUIDE RAIL**



DESIGN SPEED GREATER THAN 45 MPH (TL-3)



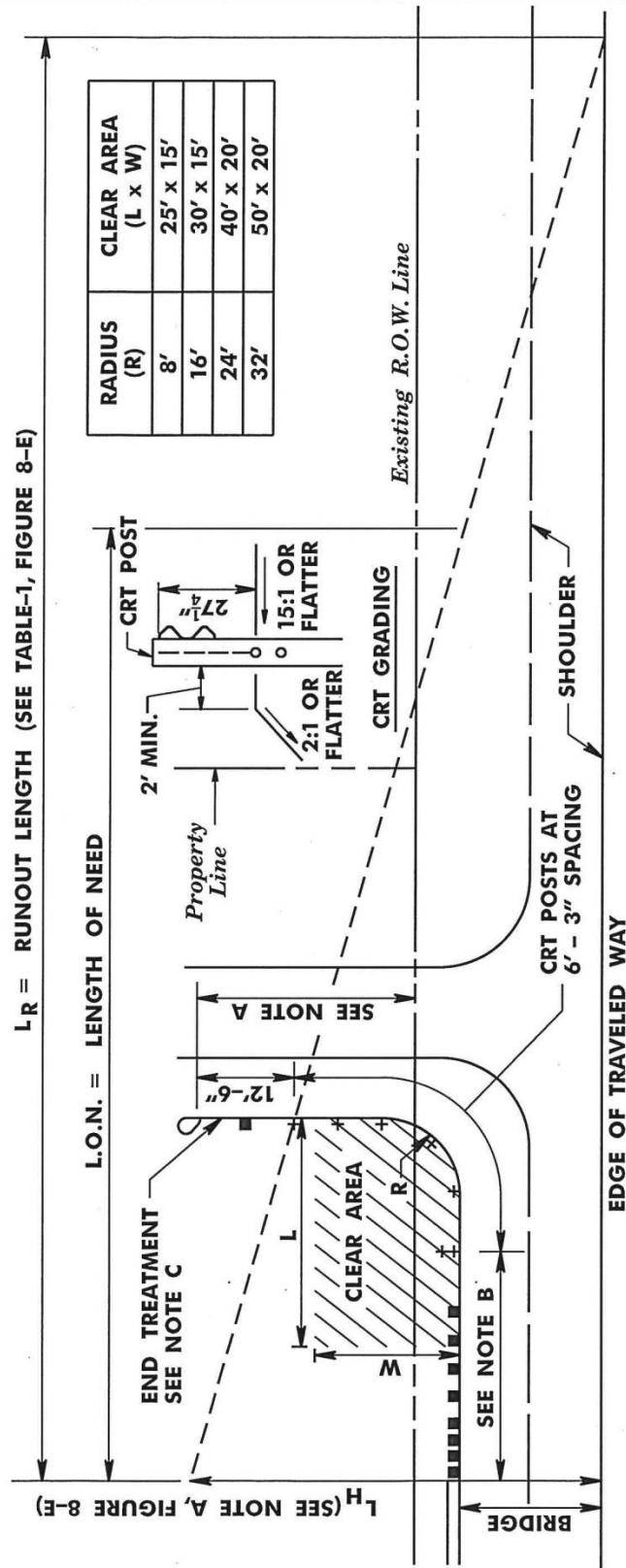
DESIGN SPEED 45 MPH OR LESS (TL-2)

NOTES

- A. See Standard Roadway Construction Details.
- B. Any multiple of 6'-3" may be added to the minimum length if a longer length of guide rail is required.
- C. The designer should indicate the type of attachment on the plans (TL-2 or TL-3).

MAY 2017

**FIGURE 8-P1:
EXAMPLE OF A CONTROLLED RELEASE TERMINAL
AT DRIVEWAY LOCATED WITHIN LENGTH OF NEED**



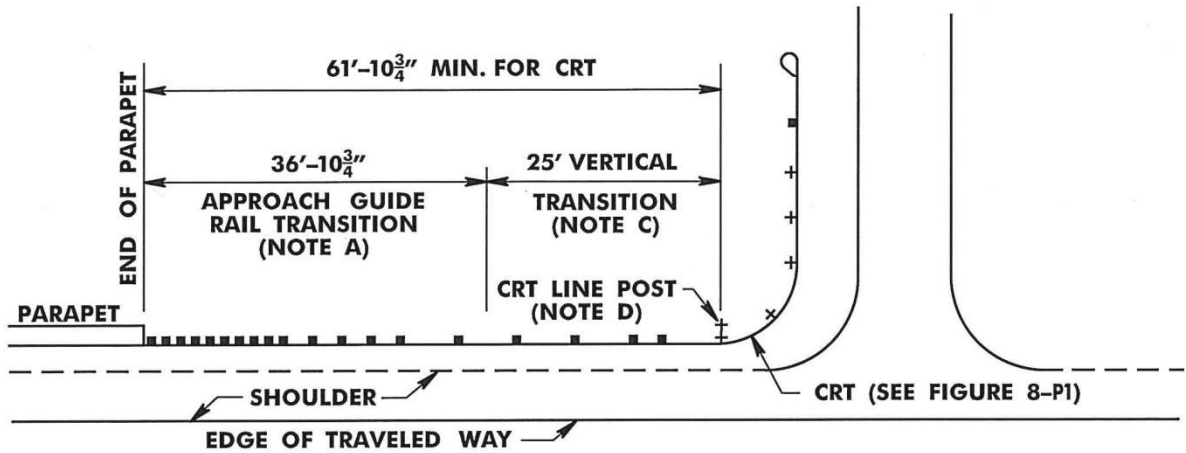
STEP 1: See steps 1 to 3 in Figure 8-O1. If there is insufficient length for Figure 8-O1, try using Figure 8-P1 or a crash cushion.

NOTES

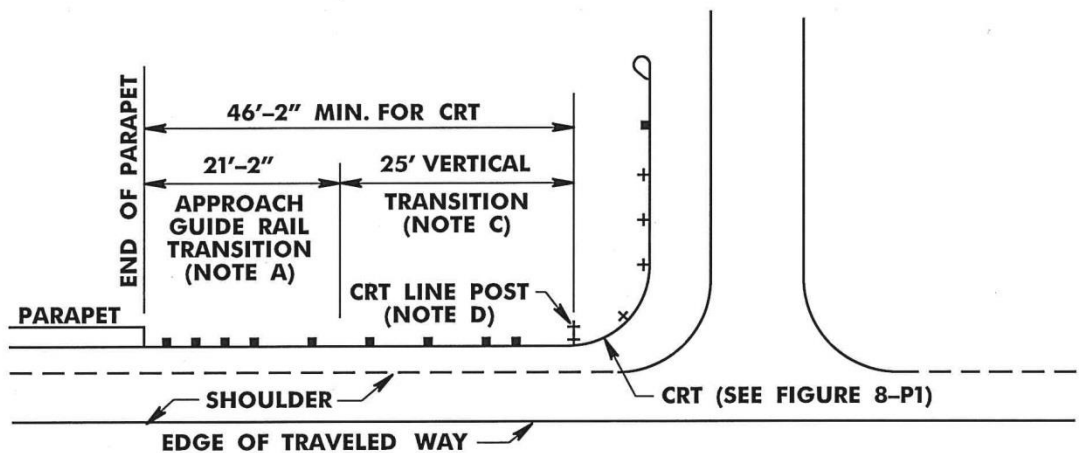
- A. A Right of Way fee parcel is required for the guide rail system and grading outside the R.O.W. line. A construction and maintenance easement parcel is required for the clear area outside the R.O.W. line. If the guide rail system ties into existing guide rail outside the R.O.W. line, then a construction and maintenance easement is required for the guide rail system, grading, and clear area.
- B. Approach guide rail transition or standard guide rail or as required. A minimum 25' vertical transition is required between the approach guide rail transition or standard guide rail to transition from a 31" rail height to a 27.25" rail height for the Controlled Release Terminal. For bridge attachments see Figure 8-P2 for minimum lengths of guide rail.
- C. Where the driveway is 'in only' or the exit driveway speed is 25 M.P.H. or less, use the Controlled Release Terminal Anchorage. Where the exit speed is greater than 25 M.P.H., use a flared or tangent terminal.
- D. This guide rail treatment is not applicable where sidewalk is located behind guide rail.
- E. For hardware information and each CRT radius design, see CD-609-6. These designs are based on an intersecting angle of 90 degrees. If field conditions vary considerably from 90 degrees, a special detail shall be made of the curved guide rail section so that the curved rails will fit the driveway or intersection geometry and that only full sections of rail element will be shop bent for installation.
- F. If curb or raised berm is present and cannot be removed, see Section 8.3.2.D.1.

MAY 2017

**FIGURE 8-P2:
APPROACH GUIDE RAIL TRANSITION
MINIMUM LENGTH OF GUIDE RAIL FOR CRT**



DESIGN SPEED GREATER THAN 45 MPH (TL-3)



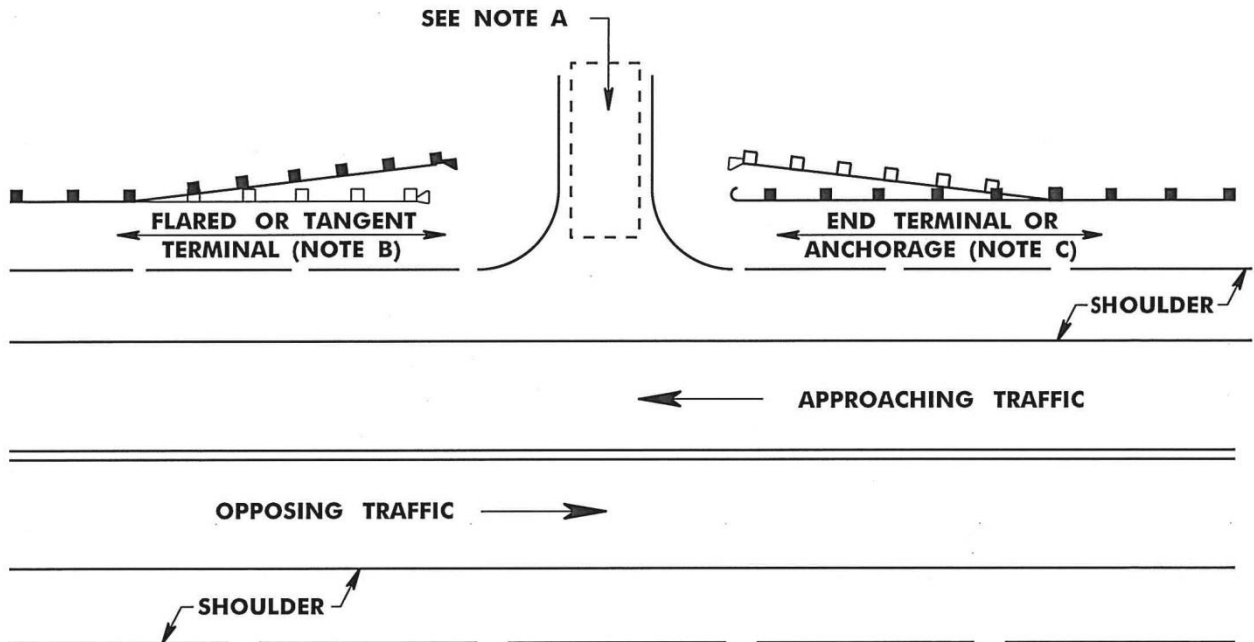
DESIGN SPEED 45 MPH OR LESS (TL-2)

NOTES

- See Standard Roadway Construction Details.
- The designer should indicate the type of attachment on the plans (TL-2 or TL-3).
- A minimum 25' vertical transition is required to transition from a 31" rail height for standard guide rail to a 27.25" rail height for the CRT. See CD-609-6.
- See CD-609-6 for location of CRT line post for various CRT radii.

MAY 2017

**FIGURE 8-Q:
EXAMPLE OF A TREATMENT AT DRIVEWAY OPENING
LOCATED WITHIN A CONTINUOUS GUIDE RAIL RUN**

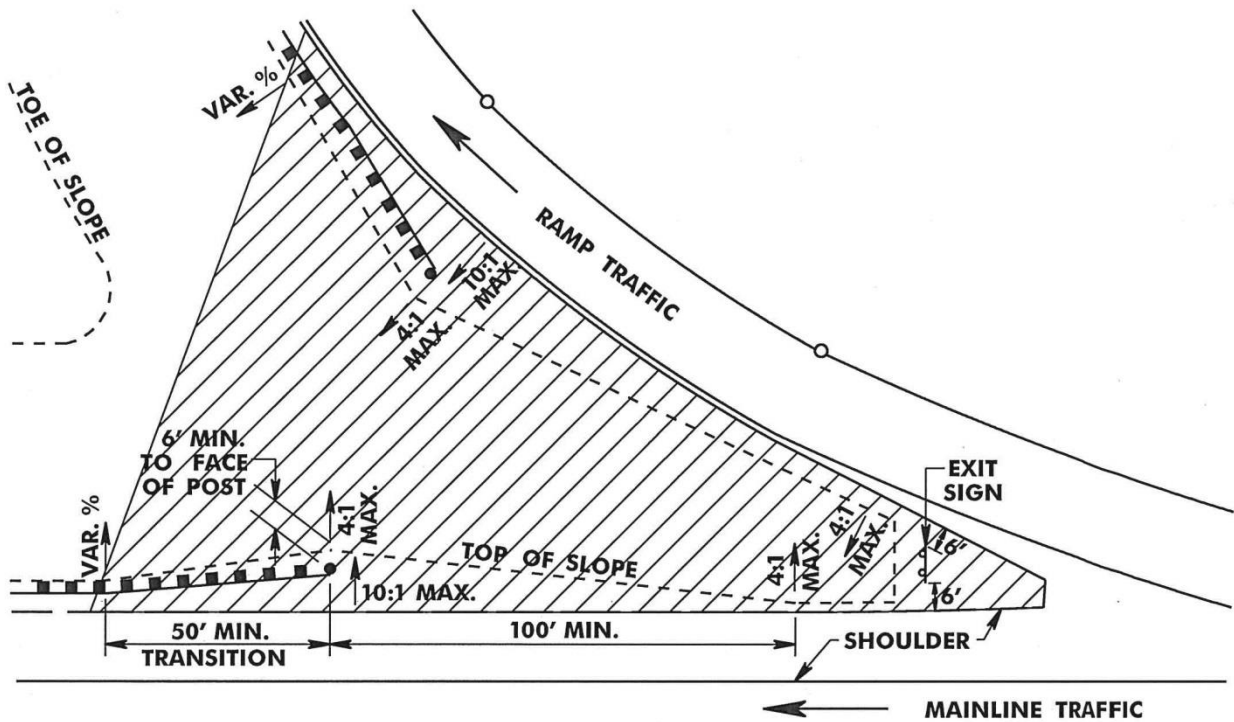


NOTES

- A. Check sight distance at driveway, see Figure 6-A. Draw a line of sight for vehicle exiting driveway. Position guide rail at driveway so it does not interfere with the line of sight.
- B. A flared terminal is preferred, however, a tangent terminal may be used. The slope treatment at a flared terminal may require slope easement parcels. See Figure 8-F for standard and alternate grading for flared and tangent terminals.
- C. End terminal or anchorage, see Figure 8-11. If an end terminal is required, a tangent terminal is preferred, however, a flared terminal may be required to obtain proper sight distance for vehicles exiting the driveway.

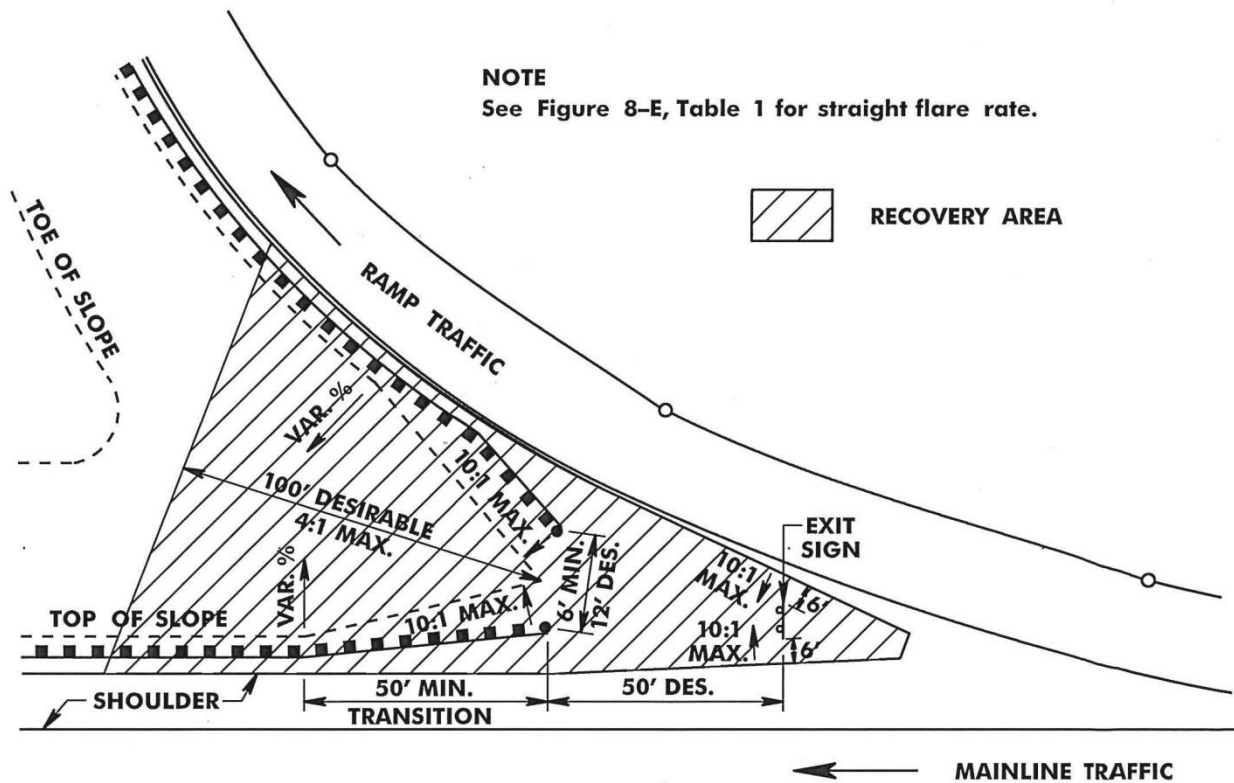
MAY 2017

**FIGURE 8-R:
GUIDE RAIL TREATMENT EXAMPLES FOR
OPEN GORE AREAS**



NOTE
See Figure 8-E, Table 1 for straight flare rate.

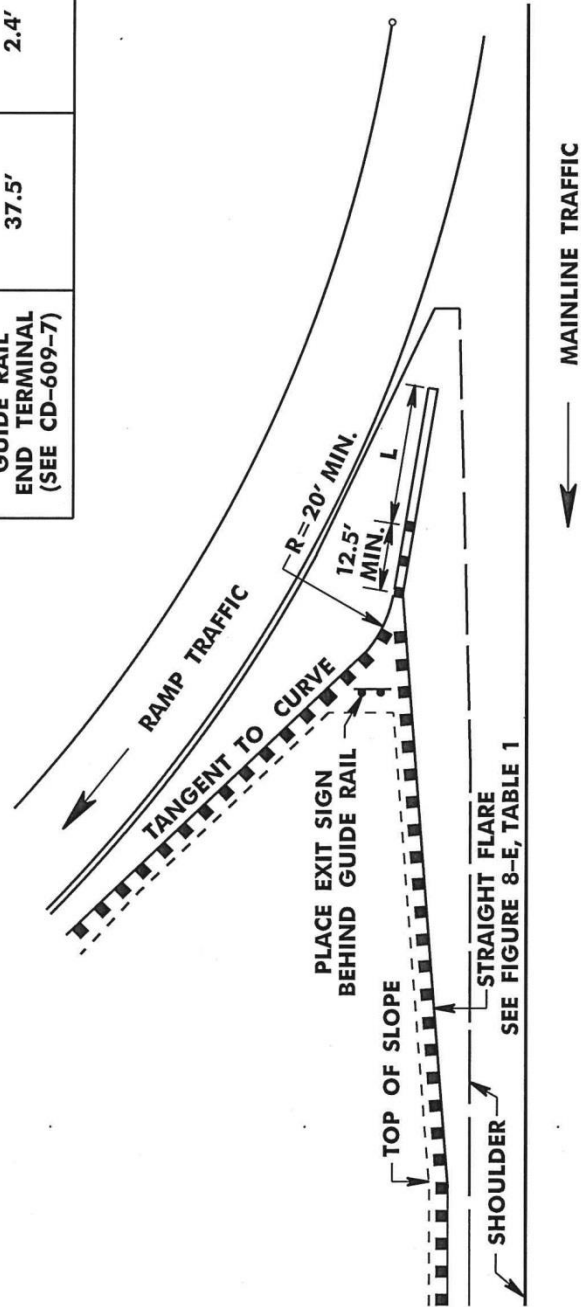
 **RECOVERY AREA**



MAY 2017

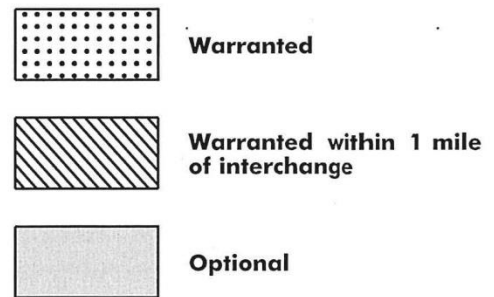
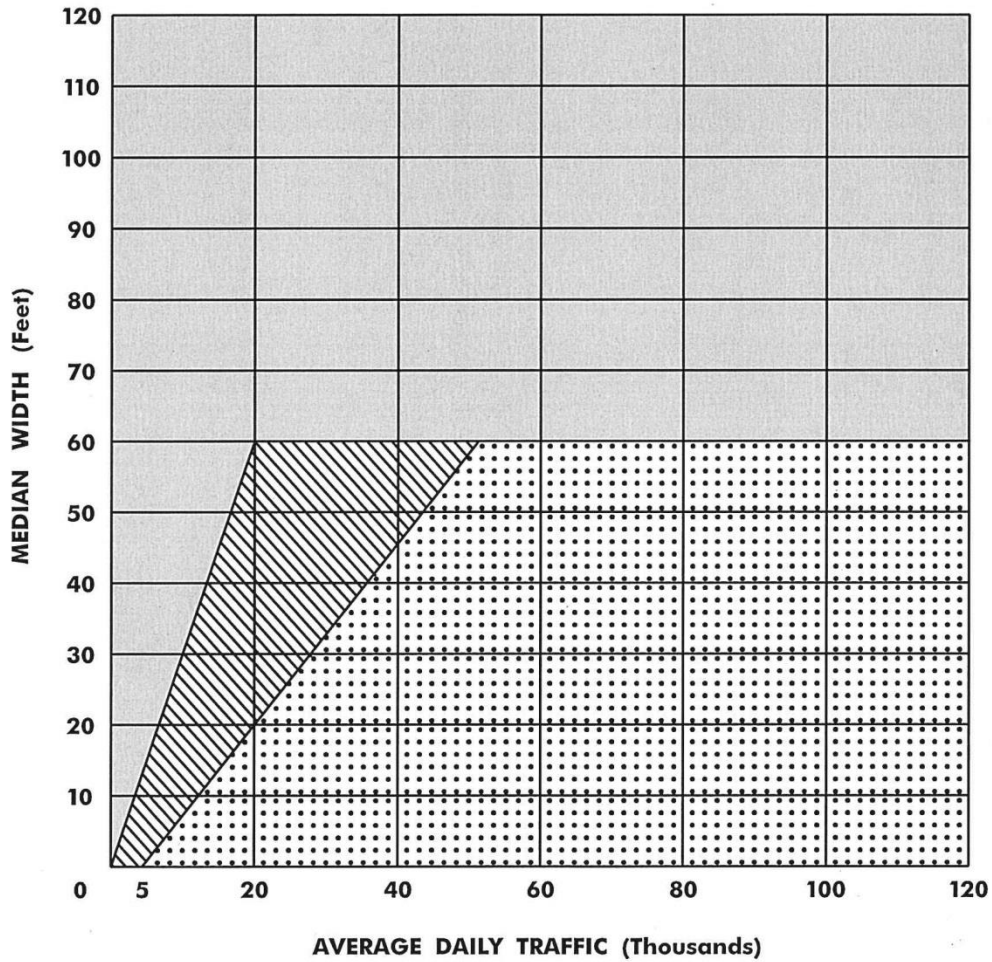
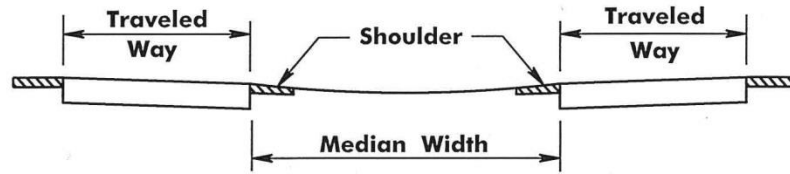
**FIGURE 8-S:
GUIDE RAIL TREATMENT EXAMPLES FOR
LIMITED GORE AREAS**

END TREATMENT		
TYPE	LENGTH (L)	WIDTH
TELESCOPING GUIDE RAIL END TERMINAL (SEE CD-609-7)	SEE SECT. 9 37.5'	2' MIN. 2.4'



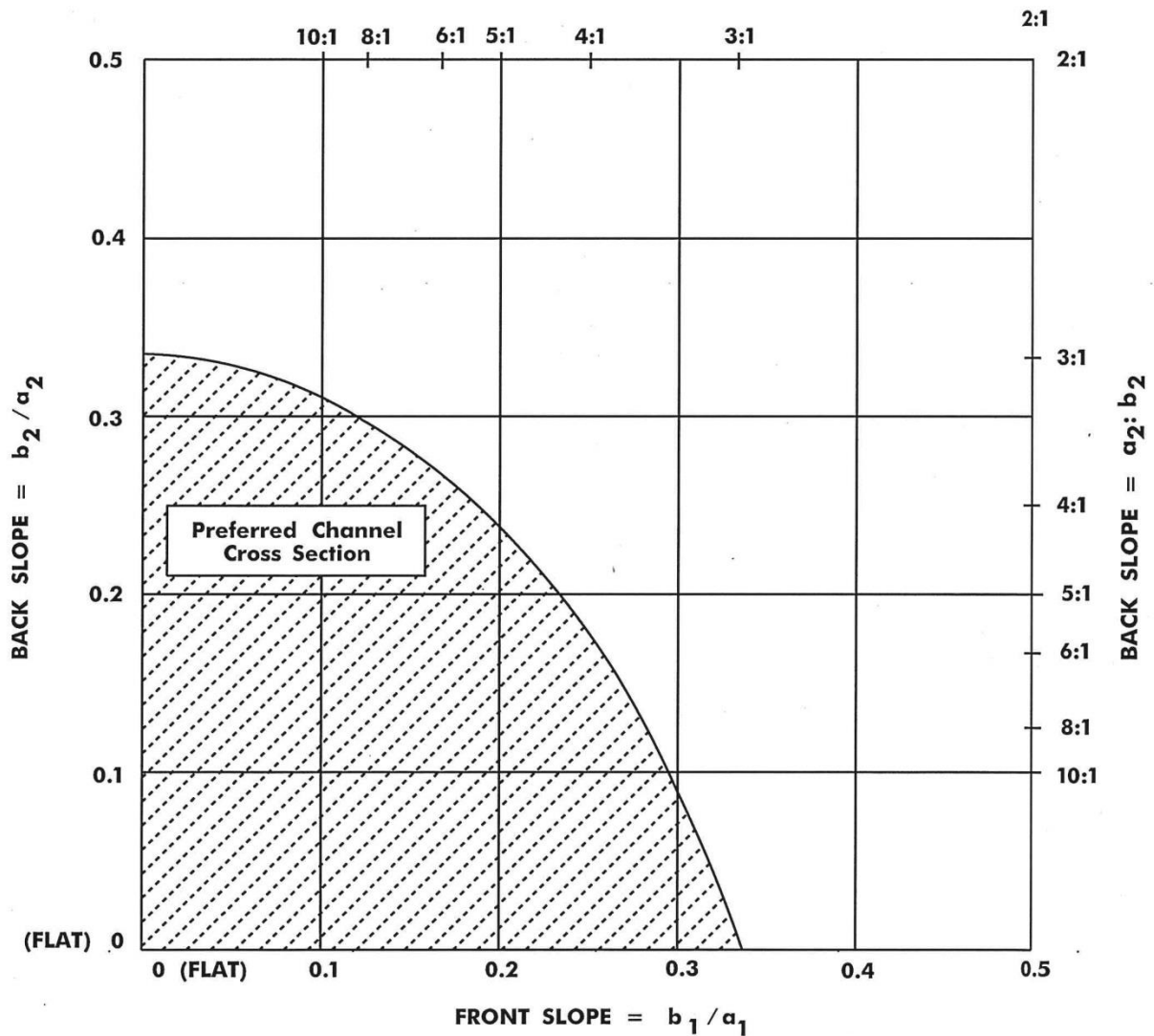
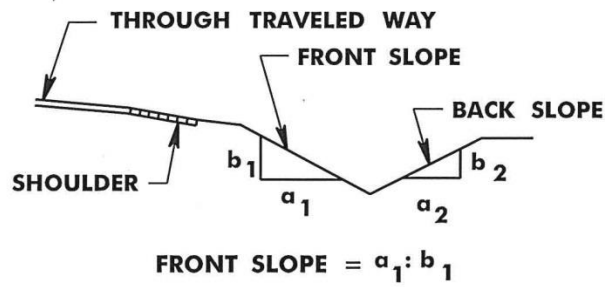
MAY 2017

FIGURE 8-T: WARRANTS FOR MEDIAN BARRIER FOR FREEWAYS AND EXPRESSWAYS



MAY 2017

FIGURE 8-U: PREFERRED CROSS SECTIONS FOR CHANNELS WITH ABRUPT SLOPE CHANGES



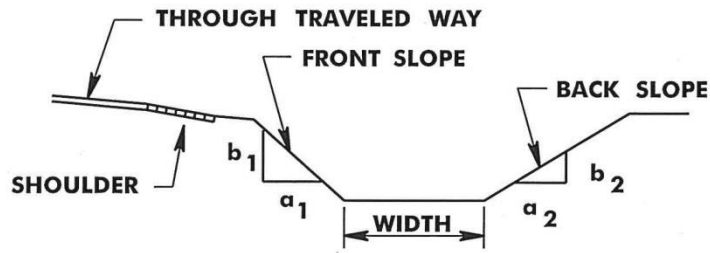
NOTE:

This chart is applicable to all vee ditches, rounded channels with bottom widths less than 8 feet, and trapezoidal channels with bottom widths less than 4 feet.

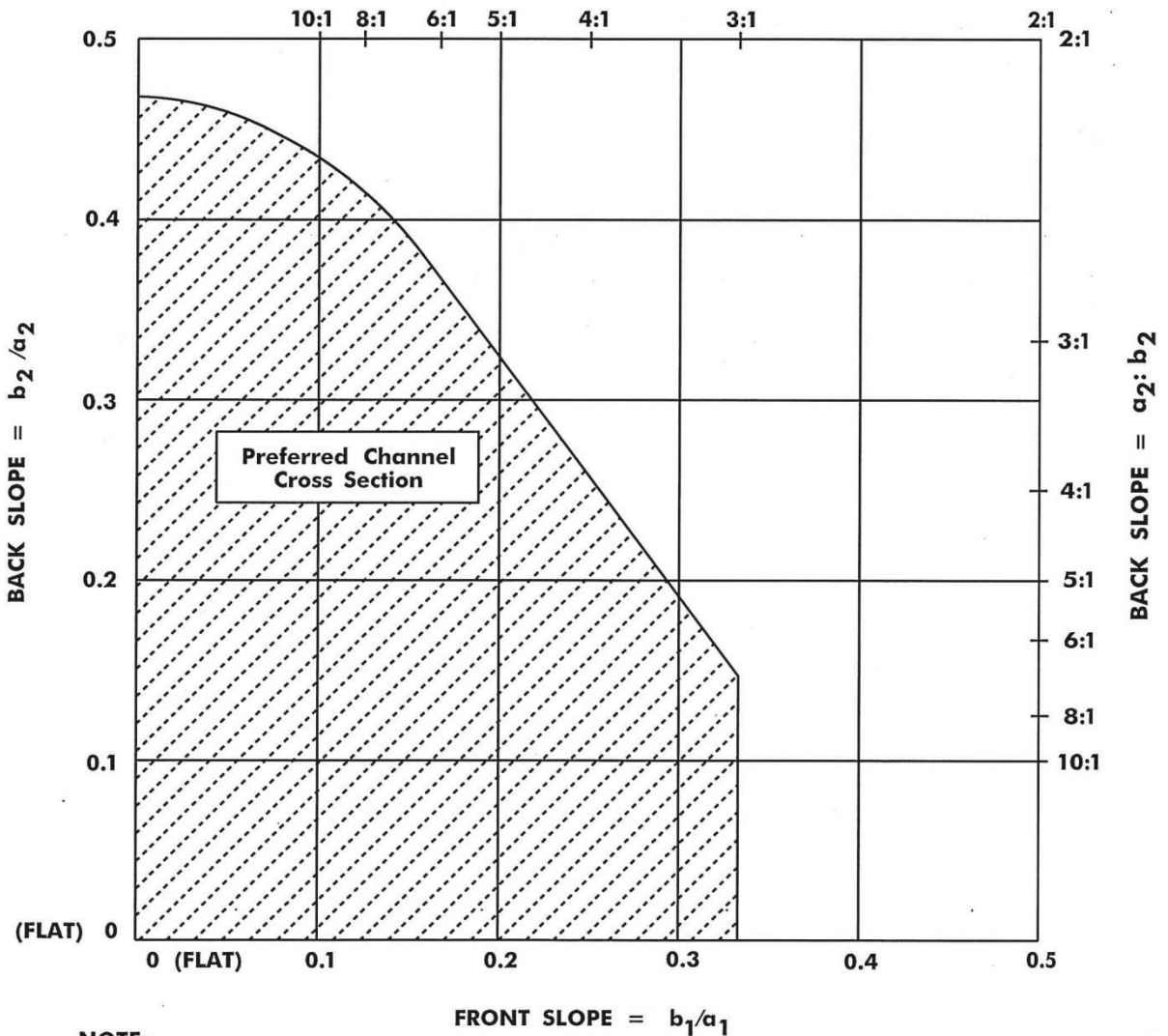
SOURCE: "Chapter 3: Roadside Topography and Drainage Features." Roadside Design Guide, 4th Edition, AASHTO, 2011

MAY 2017

**FIGURE 8-V:
PREFERRED CROSS SECTIONS FOR CHANNELS
WITH GRADUAL SLOPE CHANGES**



FRONT SLOPE = $a_1 : b_1$



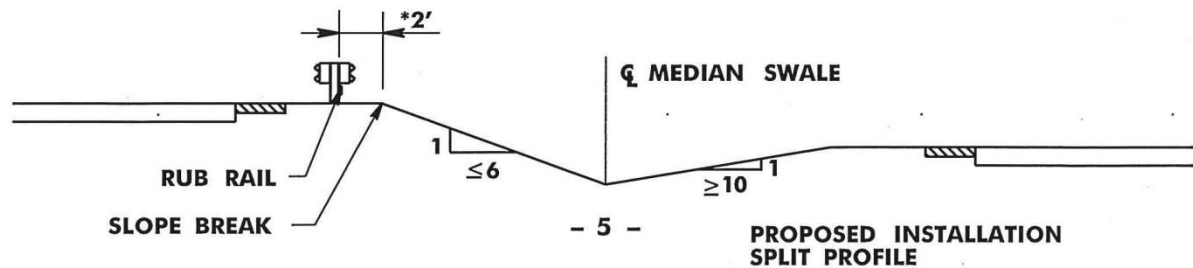
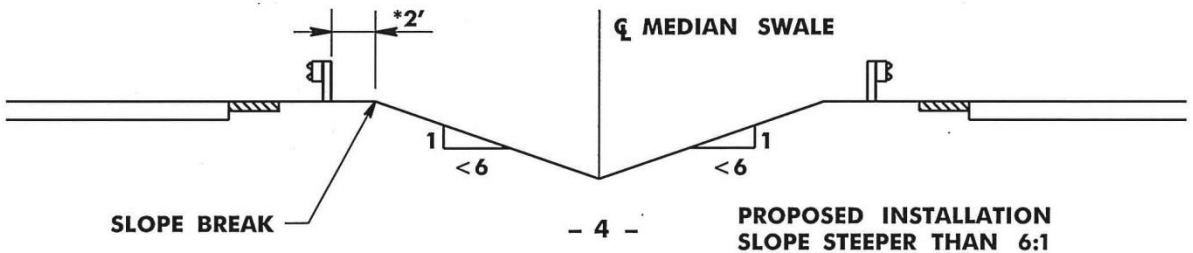
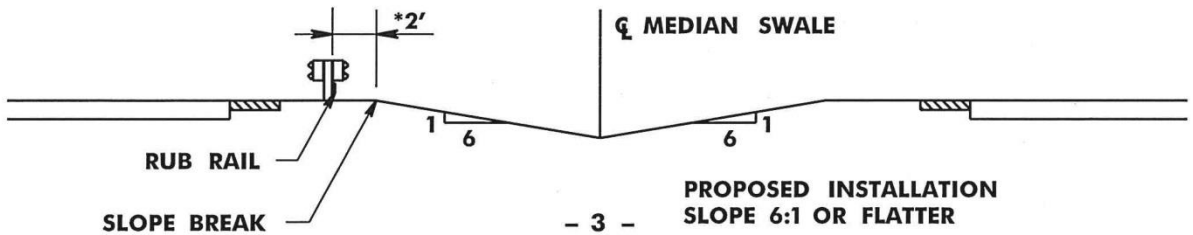
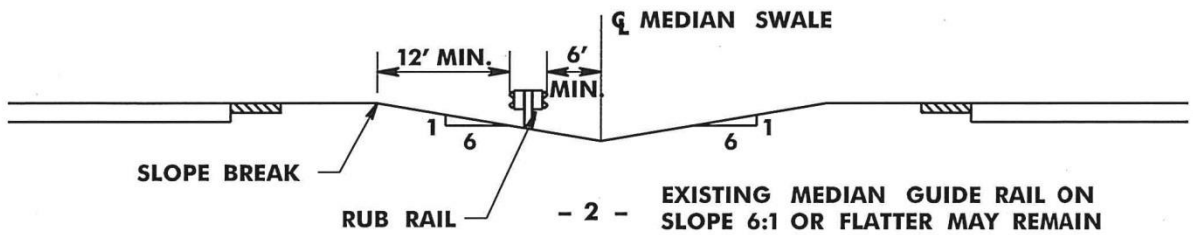
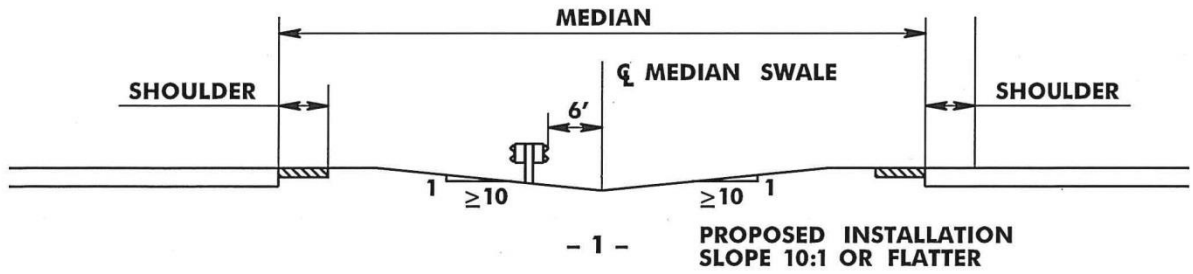
NOTE:

This chart is applicable to rounded channels with bottom widths of 8 feet or more, and to trapezoidal channels with bottom widths equal to or greater than 4 feet.

SOURCE: "Chapter 3: Roadside Topography and Drainage Features." Roadside Design Guide, 4th Edition, AASHTO, 2011

MAY 2017

FIGURE 8-W: MEDIAN GUIDE RAIL PLACEMENT

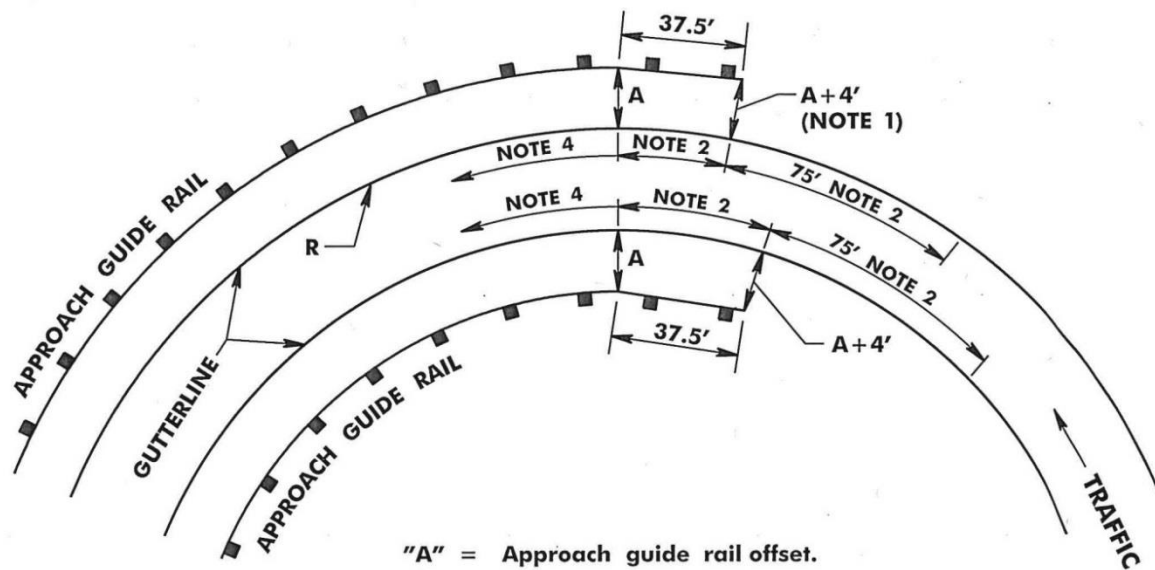


NTS

* Distance shown is 2' minimum from the back of post to the slope break. If less than 2' is used, the post embedment shall be increased in accordance with Table 8-3.

MAY 2017

FIGURE 8-X: FLARED GUIDE RAIL TERMINALS ON HORIZONTAL CURVES

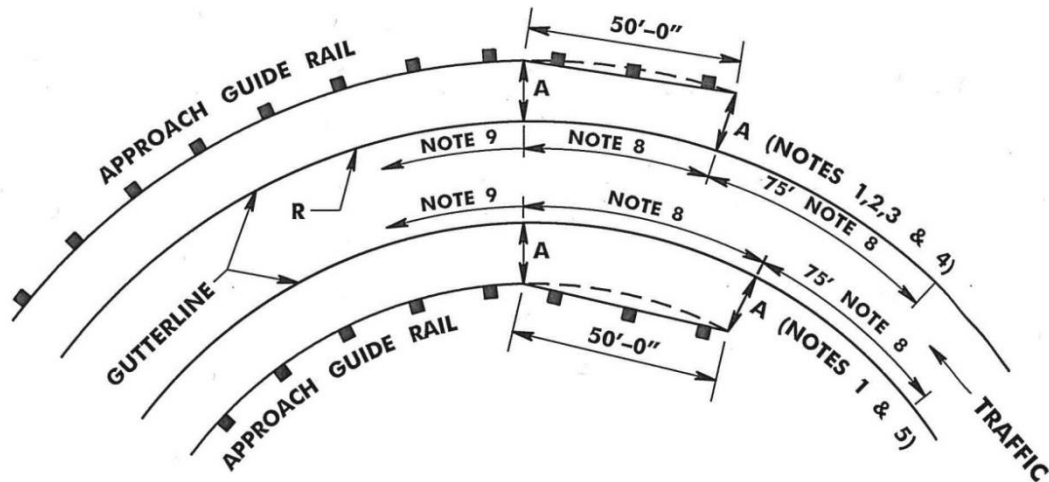


NOTES

1. To avoid installing the flared terminal within the roadway, the horizontal radius (R) must not be sharper than 175 ft. where the approach guide rail offset (A) is flush with the gutterline on the outside of the curve. If the radius is sharper than 175 ft., the warranting obstruction should be relocated or the guide rail extended to a point where the radius is 175 ft. or flatter.
2. Where there is curb, the maximum curb height is 2". See CD-609-5.
3. See Figure 8-F for standard and alternate grading for flared and tangent terminals.
4. Where there is curb, the maximum curb height is 4".

OCTOBER 2017

FIGURE 8-Y: TANGENT GUIDE RAIL TERMINALS ON HORIZONTAL CURVES



"A" = Approach guide rail offset.

NOTES

1. Desirable the end of the tangent terminal should be at the same offset as the approach guide rail.
2. Where the horizontal radius (R) is flatter than 1,250 ft. and the approach guide rail offset (A) is flush with the gutterline, the end of the tangent terminal should be offset 1 ft. from gutterline.
3. Where the horizontal radius (R) is 625 ft. or flatter but less than 1,250 ft. and the approach guide rail offset (A) is flush with the gutterline, the end of the tangent terminal should be offset 2 ft. from gutterline.
4. For other combinations of radii and offset, the designer should make sure the tangent terminal does not encroach into the roadway. In no case should the end of the tangent terminal be offset more than 2 ft. greater than the approach guide rail offset.
5. Where the approach guide rail offset (A) is flush with the gutterline, the end of the tangent terminal should be offset 1 ft. from gutterline.
6. Where the approach guide rail is flush with the back of sidewalk, the offset to the end of the tangent terminal from the back of sidewalk should be in accordance with the offsets referenced in Notes 2, 3, 4, and 5 above.
7. See Figure 8-F for standard and alternate grading for flared and tangent terminals.
8. Where there is curb, the maximum curb height is 2". See CD-609-5.
9. Where there is curb, the maximum curb height is 4".

OCTOBER 2017

Section 9 - Crash Cushions

9.1 Introduction

Fixed objects within the clear zone distance should be removed, relocated or modified so as to be breakaway. When this is not practical, the obstruction should be shielded so as to prevent an impact of the obstruction by an errant vehicle.

A detailed discussion on warranting obstructions and clear zone distance can be found in Section 8, "Guide Rail Design and Median Barriers".

A crash cushion is a type of traffic barrier that can be used to shield warranting obstructions such as overhead sign supports, bridge piers, bridge abutments, ends of retaining walls, bridge parapets, bridge railings, longitudinal barriers, etc. Due to the maintenance needs of crash cushions, the designer should, when practical, attempt to place obstructions beyond the clear zone, or provide designs that will avoid the need to require shielding by a crash cushion.

The most common use of a crash cushion is to shield a warranting obstruction in a gore. However, warranting obstructions in the median and along the roadside can also be shielded with a crash cushion (see Figure 9-A).

9.2 Selection Guidelines

9.2.1 General

Once it has been determined that a crash cushion is to be used to shield a warranting obstruction, a choice must be made as to which crash cushion is best for the particular location under consideration.

Several factors must be evaluated when determining which of the recommended crash cushions should be used. There is therefore no simple, systematic selection procedure. The factors that normally should be considered are briefly discussed in the following later subsections:

- Dimensions of the Obstruction
- Space Requirement
- Geometrics of the Site
- Physical Conditions of the Site
- Redirection Characteristics
- Design Speed
- Foundations
- Backup Structure Requirements
- Anchorage Requirements
- Flying Debris Characteristics
- Initial Cost
- Maintenance

In many cases, evaluation of the first few items will establish the type of crash cushion to be used. When designing a crash cushion, review the design instructions and product limitations in the manufacturer's design manual thoroughly before performing the necessary work.

The following crash cushions are presently recommended for permanent and temporary installations (Subsections 9.2.1.A thru E) on Departmental projects. Existing crash cushions that are not of the type listed below shall be evaluated to determine whether repairs or replacement are necessary.

A. Inertial Barriers

The following inertial barriers may be used in permanent and temporary installations. These barriers consist of sand filled plastic barrels containing varying amounts of sand ranging from 200 lbs to 1400 lbs. Sand filled plastic barrels when impacted at an angle near the front of the system allow an impacting vehicle to pass through (gating). When impacted on the side, the system will contain and capture the impacting vehicle (non-redirective).

1. Energite III Inertial Barrier
2. Universal Inertial Barrier
3. Big Sandy Inertial Barrier

B. Compressive Barriers

The following compressive barrier systems may be used in permanent installations. When impacted at an angle near the front of the system, the barrier will capture the errant vehicle (non-gating), and when impacted downstream from the front of the system, it will redirect the vehicle away from the hazard. These systems can be installed between opposing directions of traffic (bidirectional). However, a transition will be required on the reverse traffic side of the backup structure.

1. Quad Guard II
 - Shield narrow to x-wide obstructions
 - Design speeds 25 to 70 mph
 - See Table 9-1
2. SCI
 - Shield narrow to x-wide obstructions
 - Design speeds 25 to 70 mph
 - See Table 9-2
3. TRACC
 - Shield narrow to wide obstructions
 - Design speeds 25 to 70 mph
 - See Table 9-3
4. Universal TAU-II
 - Shield narrow to x-wide obstructions
 - Design speeds 25 to 70 mph
 - See Table 9-4

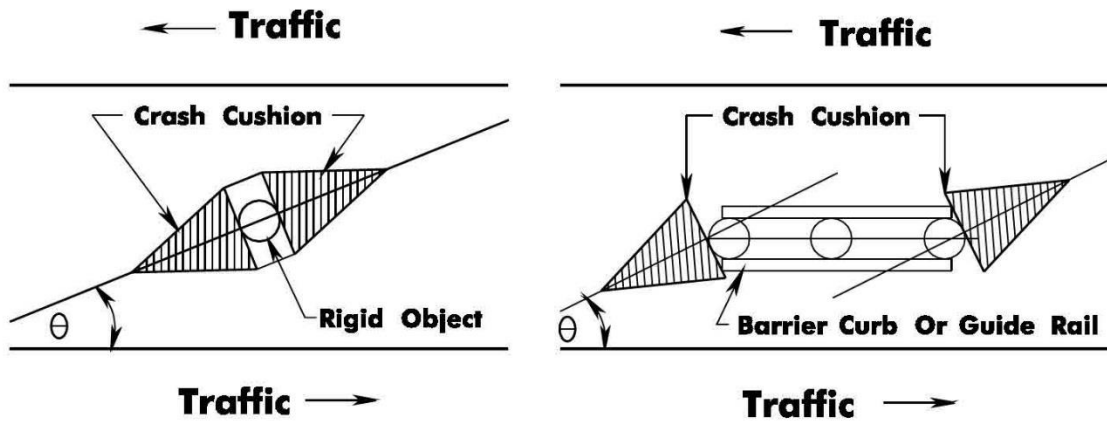
C. Low Maintenance Compressive Barriers

Low maintenance compressive barrier systems shall be used in permanent installations to shield obstructions when the posted speed is 45 mph or greater, the ADT is 25,000 or greater and the through lane would need to be closed while repairs are being made. In addition, a low maintenance compressive barrier should be used in gore areas when the horizontal and/or vertical sight distance approaching the gore area requires a design exception. A low maintenance compressive barrier should also be installed to replace an existing standard compressive barrier or inertial barrier that has been impacted two or more times within an eight-year period.

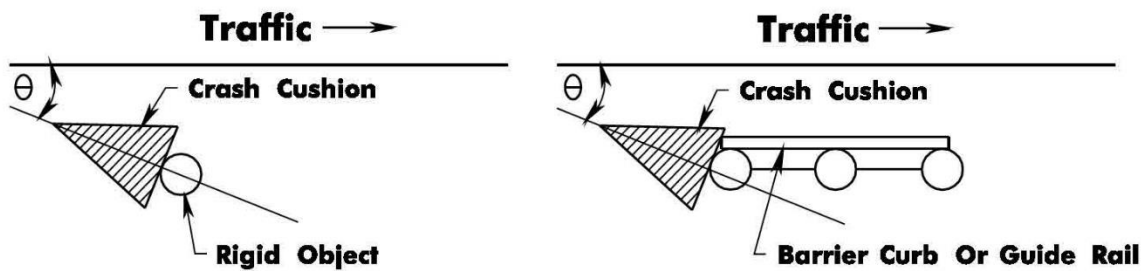
The following low maintenance compressive barrier systems are energy absorbing crash cushions that are bidirectional, non-gating, redirective and reusable.

FIGURE 9-A: CRASH CUSHION

FLAT * MEDIANS



FLAT * ROADSIDE AREA



θ = 10 DEGREES MAX
 * = SLOPE 8% OR LESS

REV. DATE: JUNE 30, 2016

1. Quad Guard Elite
 - Shield narrow to x-wide obstructions
 - Design speeds 25 to 70 mph
 - See Table 9-5
2. REACT 350 & REACT 350 II
 - Shield medium width obstructions
 - Design speeds 25 to 70 mph
 - See Table 9-6
3. SCI
 - Shield narrow to x-wide obstructions
 - Design speeds 25 to 70 mph
 - See Table 9-2

D. Temporary Compressive Barriers

The following temporary compressive barriers are energy absorbing crash cushions that are bidirectional, non-gating and redirective.

1. QuadGuard II CZ
 - Shield narrow and medium obstructions
 - Design speeds 25 to 70 mph
 - See Table 9-7
2. SCI
 - Shield narrow to x-wide obstructions
 - Design speeds 25 to 70 mph
 - See Table 9-2
3. TRACC
 - Shield narrow to wide obstructions
 - Design speeds 25 to 70 mph
 - See Table 9-3
4. Universal TAU-II
 - Shield narrow to x-wide obstructions
 - Design speeds 25 to 70 mph
 - See Table 9-4

E. Temporary Low Maintenance Compressive Barriers

The criteria for when to use a temporary low maintenance compressive barrier are the same as that for low maintenance compressive barriers and should be used when the temporary barrier will be in place for a year or more. The following temporary low maintenance compressive barriers are energy absorbing crash cushions that are bidirectional, non-gating and redirective.

1. REACT 350WZ & REACT 350 II WZ
 - Shield medium width obstructions
 - Design Speeds 25 to 70 mph
 - See Table 9-8

2. SCI

- Shield narrow to x-wide obstructions
- Design Speeds 25 to 70 mph
- See Table 9-2

9.2.2 Dimensions of the Obstruction

Inertial barriers can be designed to shield obstructions of practically any width. Compressive barrier systems (QuadGuard II, TAU-II, TRACC and SCI systems) are used to shield obstructions ranging in width from 2 feet to a maximum of 10.5 feet. Tables 9-1 through 9-8 provides design criteria (system width, system length and design speed) for approved compressive barrier systems. These tables are provided for informational purposes only. The designer should refer to the manufacturer's product manual for the most up to date information. When the distance in front of the obstruction that is available for the installation of a compressive crash cushion is very limited, the designer shall contact the supplier/manufacturer to determine the exact distance from the front of the crash cushion to the obstruction.

The maximum width of the obstruction for the standard QuadGuard II and TAU-II systems are 10.5 feet and 8.5 feet, respectively. The TRACC, ShorTRACC and FasTRACC have a maximum width of 2.5 feet. However, the WideTRACC has a standard width of 41 inches when flared on one side and 58 inches when flared on both sides and both are 21 feet long. The WideTRACC can also be customized to fit any width by adding 2.33 feet of length and 6 7/8 inches in width for each section when widening on both sides, and 3 7/16 inches in width for widening on one side. The standard SCI system is designed to shield obstructions 24 inches wide. However, wider obstructions can be shielded by using transition assemblies available from the manufacturer to shield obstructions up to 180 inches wide. The transition assemblies increase the overall length of the SCI system from approximately 28 feet to approximately 60 feet depending upon the width being shielded.

Use compressive barriers (QuadGuard II, SCI, Universal TAU II, or TRACC Systems) or, when warranted, a low maintenance compressive barrier (QuadGuard Elite, REACT 350, REACT 350 II, or SCI Systems) as a crash cushion treatment at barrier curb openings in the median.

When a low maintenance compressive barrier (QuadGuard Elite, REACT 350, REACT 350 II and SCI) is warranted the following apply:

A. QuadGuard Elite

1. The QuadGuard Elite can be used to shield obstructions up to 7.5 feet wide and is available in five nominal widths (24", 30", 36", 69" and 90").

B. REACT 350 or REACT 350 II

1. The REACT 350 is to be used for design speeds of 45 mph and less and the REACT 350 II is used when the design speed is 50 mph or greater.
2. The REACT 350 and REACT 350 II are available in widths of 36", 60", 96" and 120". However, because of their cost, widths greater than 36" are not recommended on Department projects.
3. When using a Self-Contained Backup, the width of the obstruction is limited to 8" in gore areas. Obstructions in non-gore area may be up to 24" wide. If used to shield the end of 24" wide median barrier curb, it is recommended that the shoulder be a minimum of 3' wide and the end of the barrier be tapered in accordance with the manufacturer's recommendation. Transition hardware is

required to connect the Self-Contained Backup to the barrier. If the obstruction has a vertical shape, the system shall be offset from the obstruction toward traffic on the approach side. The offset is accomplished by aligning the vertical face of the cylinder with the rear or trailing face of the vertical barrier/obstruction.

4. If a concrete backup is used, the width of the obstruction that can be shielded may be up to 36" wide. However, when used in the median on bidirectional roadways, the shoulder width must be a minimum of 3' wide, and a 10' long tapered section must be provided. The minimum dimensions of the concrete backup must meet the manufacturer's recommendations.

C. SCI

1. The SCI system is designed to shield obstructions up to 24 inches wide. However, wider obstructions can be shielded by using transition assemblies to shield obstructions greater than 24 inches to 180 inches wide. The use of transition assemblies greater than 120 inches is not recommended. Transition assemblies will increase the system length of the SCI100GM from approximately 22 feet for an obstruction 24 inches wide to approximately 47 feet for an obstruction 120 inches wide.

When there is sufficient area in advance of a wide obstruction, the designer should consider providing a barrier curb or guide rail transition to avoid using a compressive crash cushion wider than 30 inches or low maintenance compressive crash cushion wider than 36 inches. The transition to a wide obstruction should not begin at the back of the crash cushion. A short section of roadside barrier (concrete barrier curb or beam guide rail) shall be provided between the crash cushion and the beginning of the transition. The minimum length of concrete barrier curb or beam guide rail prior to the transition should be 10 feet and 12.5 feet, respectively.

Crash cushions are not ordinarily used along the length of an obstruction. Usually guide rail or barrier curb is used. Figure 9-A shows typical installations where a crash cushion is used in conjunction with a barrier curb or guide rail.

9.2.3 Space Requirement

A. Area Occupied by the Crash Cushion

The compressive barrier systems generally require about 20 percent less length than an inertial barrier. To meet the requirement of Figure 9-B, inertial barriers will have a minimum width of approximately 6.5 feet (two barrels each at three feet wide plus a six inch space between them).

See Table 9-1 through 9-8 for design criteria (system width, system length and design speed) for the approved compressive barrier systems. The design criteria in Tables 9-2, 9-3 and 9-4 are also applicable to the Temporary crash cushions for the SCI, TRACC and Universal TAU-II, respectively. In addition, the design criteria in Table 9-2 apply to the SCI low maintenance attenuator. The widths are separated into 4 categories: narrow (24" to 30"), medium (greater than 30" to 48"), wide (greater than 48" to 72") and x-wide (greater than 72").

B. Reserve Area for Crash Cushion

Figure 9-C shows dimensions to be used in determining if adequate space is available for the installation of a crash cushion. Although it depicts a gore location, the same

recommendations will apply to other types of obstructions that require shielding by a crash cushion. Also, Figure 9-C shows a range of dimensions, the significance of which is as follows:

1. Minimum

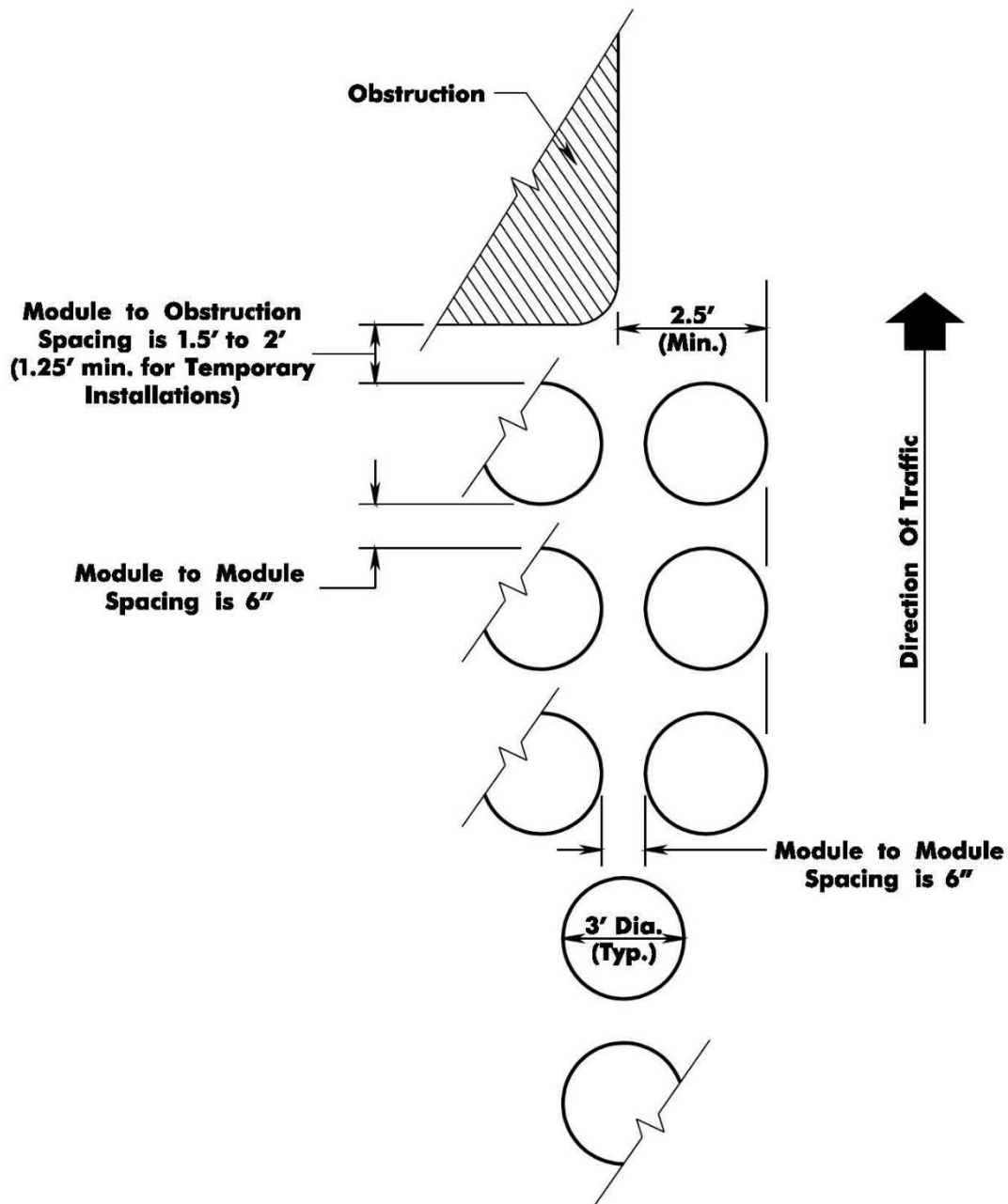
Restricted Conditions - These dimensions approximately describe the space required for installation of the current generation of crash cushion devices without encroachment on shoulders and the nose of the device offsets slightly back of the parapet or shoulder line. However, there are designs already developed that would not fit in the space provided by these dimensions and quite often it will not be possible to provide the recommended reserve area, particularly on existing roadways. In either case, the crash cushion should be designed to not encroach into the shoulder. In extreme cases, where the crash cushion must encroach into the shoulder, a low maintenance compressive barrier system should be considered since a higher than normal frequency of impacts could reasonably be expected when the crash cushion is closer to the traveled way.

Unrestricted Conditions - These dimensions should be considered as the minimum for all projects where plan development is not far advanced except for those sites where it can be shown that the increased cost for accommodating these dimensions, as opposed to those for Restricted Conditions, will be unreasonable. For example, if the use of the greater dimensions would require the demolition of an expensive building or a considerable increase in construction costs, then the lesser dimensions might be considered.

2. Preferred

These dimensions, which are considerably greater than required for the present generation of crash cushions should also be considered optimum. This does not imply that if space is provided in accordance with these dimensions that it will be fully occupied by a crash cushion. The reason for proposing these dimensions is to make allowance for future design and device installation suitable for greater ranges of vehicle weights and/or for lower deceleration forces if experience determines that such may be necessary. In the meantime, the unoccupied reserved crash cushion space will provide valuable additional recovery area.

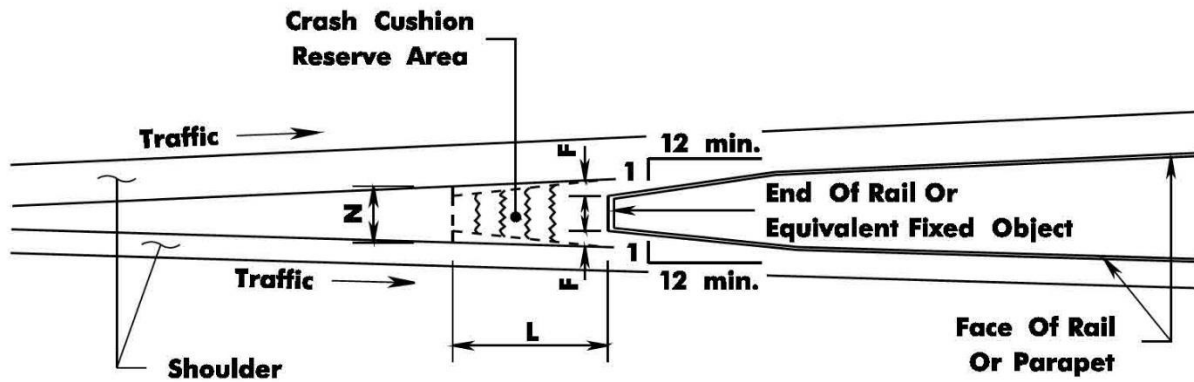
**FIGURE 9-B:
SUGGESTED LAYOUT FOR LAST THREE MODULE ROWS
IN AN INERTIAL BARRIER**



NOTE: A minimum of two modules must be provided in the last three rows.

REV. DATE: JUNE 30, 2015

**FIGURE 9-C:
CRASH CUSHION RESERVE AREA DETAILS**



DESIGN SPEED ON MAINLINE (M.P.H.)	DIMENSIONS FOR CRASH CUSHION RESERVE AREA ON NEW CONSTRUCTION (FEET)								
	MINIMUM						PREFERRED		
	RESTRICTED CONDITIONS			UNRESTRICTED CONDITIONS					
	N	L	F	N	L	F	N	L	F
30	6	8	2	8	11	3	12	17	4
50	6	17	2	8	25	3	12	33	4
70	6	28	2	8	45	3	12	55	4

NOTE:

For intermediate design speeds, use the values for the higher design speed (i.e., for design speed of 40 M.P.H., use values for 50 M.P.H. design speed)

REV. DATE: JUNE 30, 2016

Table 9-1											
QuadGuard II ¹											
Width		Design Speed (mph), No. Bays, Length									
		Type 2					Type 3			Type 4	
		25	30	35	40	45	50	55	60	65	70
Narrow	24'' ²	1 Bay 6'-11'' ³	2 Bay 9'-11'' ³	2 Bay 9'-11'' ³	2 Bay 9'-11'' ³	3 Bay 12'-11'' ³	3 Bay 12'-11'' ³	4 Bay 16'-0'' ³	5 Bay 19'-0'' ³	6 Bay 22'-0'' ³	8 Bay 28'-1'' ³
	30'' ²	1 Bay 6'-11'' ³	2 Bay 9'-11'' ³	2 Bay 9'-11'' ³	2 Bay 9'-11'' ³	3 Bay 12'-11'' ³	3 Bay 12'-11'' ³	4 Bay 16'-0'' ³	5 Bay 19'-0'' ³	6 Bay 22'-0'' ³	8 Bay 28'-1'' ³
Medium	36'' ²	1 Bay 6'-11'' ³	2 Bay 9'-11'' ³	2 Bay 9'-11'' ³	2 Bay 9'-11'' ³	3 Bay 12'-11'' ³	3 Bay 12'-11'' ³	4 Bay 16'-0'' ³	5 Bay 19'-0'' ³	6 Bay 22'-0'' ³	8 Bay 28'-1'' ³
	48'' ²	1 Bay 6'-11'' ³	2 Bay 9'-11'' ³	2 Bay 9'-11'' ³	2 Bay 9'-11'' ³	3 Bay 12'-11'' ³	3 Bay 12'-11'' ³	4 Bay 16'-0'' ³	5 Bay 19'-0'' ³	6 Bay 22'-0'' ³	8 Bay 28'-1'' ³
Wide	69'' ²	3 Bay 13'-0'' ⁴	3 Bay 13'-0'' ⁴	3 Bay 13'-0'' ⁴	3 Bay 13'-0'' ⁴	4 Bay 16'-0'' ⁴	4 Bay 16'-0'' ⁴	5 Bay 19'-0'' ⁴	5 Bay 19'-0'' ⁴	6 Bay 22'-0'' ⁴	8 Bay 28'-0'' ⁴
X-Wide	90'' ²	3 Bay 13'-0'' ⁴	3 Bay 13'-0'' ⁴	3 Bay 13'-0'' ⁴	3 Bay 13'-0'' ⁴	4 Bay 16'-0'' ⁴	4 Bay 16'-0'' ⁴	5 Bay 19'-0'' ⁴	5 Bay 19'-0'' ⁴	6 Bay 22'-0'' ⁴	8 Bay 28'-0'' ⁴
	126'' ²						6 Bay 22'-0'' ⁴	6 Bay 22'-0'' ⁴	6 Bay 22'-0'' ⁴	6 Bay 22'-0'' ⁴	8 Bay 28'-0'' ⁴

- Note: 1. Design table applicable to permanent installations of compressive barriers only
2. Width = distance between fender panels
3. Length = Approximate distance from nose of unit to back of unit. Includes tension strut backup. For 1 to 3 bays, add 1'-4" for concrete backup; 4 to 7 bays add 1'-3" for concrete backup; 8 bay add 1'-2" for concrete backup.
4. Length = Approximate distance from nose of unit to back of unit. Includes tension strut backup. Add 2' for concrete backup.

Table 9-2											
SCI ¹											
Width		Design Speed (mph), Model, Length									
		Type 2					Type 3			Type 4	
		25	30	35	40	45	50	55	60	65	70
Narrow	24" ²	SCI70GM 13'-6" ³	SCI70GM 13'-6" ³	SCI70GM 13'-6" ³	SCI70GM 13'-6" ³	SCI70GM 13'-6" ³	SCI100GM 21'-6" ³	SCI100GM 21'-6" ³	SCI100GM 21'-6" ³	SCI100GM ⁴ 21'-6" ³	SCI100GM ⁴ 21'-6" ³
	30" ²	SCI70GM 18'-0" ³	SCI70GM 18'-0" ³	SCI70GM 18'-0" ⁴	SCI70GM 18'-0" ³	SCI70GM 18'-0" ³	SCI100GM 26'-0" ³	SCI100GM 26'-0" ³	SCI100GM 26'-0" ³	SCI100GM ⁴ 26'-0" ³	SCI100GM ⁴ 26'-0" ³
Medium	36" ²	SCI70GM 19'-5" ³	SCI70GM 19'-5" ³	SCI70GM 19'-5" ³	SCI70GM 19'-5" ³	SCI70GM 19'-5" ³	SCI100GM 29'-7" ³	SCI100GM 29'-7" ³	SCI100GM 29'-7" ³	SCI100GM ⁴ 29'-7" ³	SCI100GM ⁴ 29'-7" ³
	48" ²	SCI70GM 21'-10 ³	SCI70GM 21'-10 ³	SCI70GM 21'-10 ³	SCI70GM 21'-10 ³	SCI70GM 21'-10 ³	SCI100GM 29'-10 ³	SCI100GM 29'-10 ³	SCI100GM 29'-10 ³	SCI100GM ⁴ 29'-10 ³	SCI100GM ⁴ 29'-10 ³ , ³
Wide	54" ²	SCI70GM 23'-4" ³	SCI70GM 23'-4" ³	SCI70GM 23'-4" ³	SCI70GM 23'-4" ³	SCI70GM 23'-4" ³	SCI100GM 31'-4" ³	SCI100GM 31'-4" ³	SCI100GM 31'-4" ³	SCI100GM ⁴ 31'-4" ³	SCI100GM ⁴ 31'-4" ³
	72" ²	SCI70GM 27'-6" ³	SCI70GM 27'-6" ³	SCI70GM 27'-6" ³	SCI70GM 27'-6" ³	SCI70GM 27'-6" ³	SCI100GM 35'-6" ³	SCI100GM 35'-6" ³	SCI100GM 35'-6" ³	SCI100GM ⁴ 35'-6" ³	SCI100GM ⁴ 35'-6" ³
X-Wide	84" ²	SCI70GM 30'-4" ³	SCI70GM 30'-4" ³	SCI70GM 30'-4" ³	SCI70GM 30'-4" ³	SCI70GM 30'-4" ³	SCI100GM 38'-4" ³	SCI100GM 38'-4" ³	SCI100GM 38'-4" ³	SCI100GM ⁴ 38'-4" ³	SCI100GM ⁴ 38'-4" ³
	120" ²	SCI70GM 38'-10" ³	SCI70GM 38'-10" ³	SCI70GM 38'-10" ³	SCI70GM 38'-10" ³	SCI70GM 38'-10" ³	SCI100GM 46'-10" ³	SCI100GM 46'-10" ³	SCI100GM 46'-10" ³	SCI100GM ⁴ 46'-10" ³	SCI100GM ⁴ 46'-10" ³

- Note: 1. Design table applicable to permanent and temporary installations of compressive barriers and low maintenance compressive barriers. Temporary installations are only provided in narrow width.
2. Width = distance between side panels at rear of crash cushion. Obstructions wider than 24" require a transition assembly available from SCI Products, Inc.
3. Length = Approximate distance from front of crash cushion to rear of crash cushion. For widths greater than 24", the length includes a transition assembly. Although SCI Products, Inc. provides transition assemblies for any width up to 180", the use of transition assemblies greater than 120" is not recommended.
4. The SCI has been successfully crash tested to NCHRP Report 350 or MASH and is considered to be compliant and sufficient for design speeds greater than 60 mph.

Table 9-3											
TRACC¹											
Design Speed (mph), Model, Length											
Width		Type 2					Type 3			Type 4	
		25	30	35	40	45	50	55	60	65	70
Narrow	24" ²	ShorTRACC 14'-3" ³	ShorTRACC 14'-3" ³	ShorTRACC 14'-3" ³	ShorTRACC 14'-3" ³	ShorTRACC 14'-3" ³	TRACC 21'-3" ³	TRACC 21'-3" ³	TRACC 21'-3" ³	FasTRACC 26'-0" ³	FasTRACC 26'-0" ³
	30" ²	ShorTRACC 14'-3" ³	ShorTRACC 14'-3" ³	ShorTRACC 14'-3" ³	ShorTRACC 14'-3" ³	ShorTRACC 14'-3" ³	TRACC 21'-3" ³	TRACC 21'-3" ³	TRACC 21'-3" ³	FasTRACC 26'-0" ³	FasTRACC 26'-0" ³
Medium	41" ²	NA	NA	NA	NA	NA	WideTRACC 21'-0" ³	WideTRACC 21'-0" ³	WideTRACC 21'-0" ³	NA	NA
Wide	58" ²	NA	NA	NA	NA	NA	WideTRACC 21'-0" ³	WideTRACC 21'-0" ³	WideTRACC 21'-0" ³	NA	NA

- Note:
1. Design table applicable to permanent and temporary installations of compressive barriers
 2. Width = distance between side panels at rear of crash cushion
 3. Length = Approximate distance from front of crash cushion to backup frame. WideTRACC-L (left side) and WideTRACC-R (right side) have a flare on one side only and are used to shield wide obstructions. By adding extensions, wider obstructions can be shielded. Each extension adds 28 inches of length and 3 7/16 inches of width. WideTRACC-B (both sides) is flared on each side and is also used to shield wide obstructions. By adding extensions, wider obstructions can be shielded. Each extension for the WideTRACC-B adds 28 inches of length and 6 7/16 inches of width.

Table 9-4											
Universal TAU-II ^{1, 2}											
Width		Design Speed (mph), No. Bays, Length									
		Type 2					Type 3			Type 4	
		25	30	35	40	45	50	55	60	65	70
Narrow	30" ³	2 Bay 10'-0" ⁴	2 Bay 10'-0" ⁴	3 Bay 13'-0" ⁴	4 Bay 15'-9" ⁴	4 Bay 15'-9" ⁴	5 Bay 18'-6" ⁴	7 Bay 24'-3" ⁴	8 Bay 27'-3" ⁴	10 Bay 30'-0" ⁴	10 Bay 32'-9" ⁴
	36" ³	2 Bay 10'-0" ⁴	2 Bay 10'-0" ⁴	3 Bay 12'-9" ⁴	4 Bay 15'-9" ⁴	4 Bay 15'-9" ⁴	5 Bay 18'-9" ⁴	7 Bay 24'-3" ⁴	8 Bay 27'-0" ⁴	10 Bay 29'-9" ⁴	10 Bay 32'-9" ⁴
Medium	42" ³	2 Bay 10'-0" ⁴	2 Bay 10'-0" ⁴	3 Bay 12'-9" ⁴	4 Bay 15'-9" ⁴	4 Bay 15'-9" ⁴	5 Bay 18'-9" ⁴	7 Bay 24'-3" ⁴	8 Bay 26'-3" ⁴	10 Bay 29'-9" ⁴	10 Bay 32'-9" ⁴
	48" ³	2 Bay 10'-0" ⁴	2 Bay 10'-0" ⁴	3 Bay 13'-0" ⁴	4 Bay 15'-3" ⁴	4 Bay 15'-3" ⁴	5 Bay 18'-0" ⁴	7 Bay 23'-6" ⁴	8 Bay 23'-9" ⁴	10 Bay 29'-0" ⁴	10 Bay 31'-9" ⁴
	54" ³	2 Bay 10'-9" ⁴	2 Bay 10'-9" ⁴	3 Bay 13'-0" ⁴	4 Bay 15'-9" ⁴	4 Bay 15'-9" ⁴	5 Bay 18'-0" ⁴	7 Bay 23'-9" ⁴	8 Bay 26'-3" ⁴	10 Bay 29'-0" ⁴	10 Bay 31'-9" ⁴
Wide	60" ³	2 Bay 10'-9" ⁴	2 Bay 10'-0" ⁴	3 Bay 12'-9" ⁴	4 Bay 15'-9" ⁴	4 Bay 15'-9" ⁴	5 Bay 18'-3" ⁴	7 Bay 23'-6" ⁴	8 Bay 27'-0" ⁴	10 Bay 29'-0" ⁴	10 Bay 32'-9" ⁴
	66" ³			2 Bay 9'-9" ⁴	3 Bay 12'-6" ⁴	3 Bay 12'-6" ⁴	4 Bay 15'-6" ⁴	5 Bay 20'-9" ⁴	7 Bay 23'-6" ⁴	9 Bay 26'-3" ⁴	9 Bay 29'-9" ⁴
	72" ³			2 Bay 10'-0" ⁴	3 Bay 12'-6" ⁴	3 Bay 12'-6" ⁴	4 Bay 15'-6" ⁴	5 Bay 18'-9" ⁴	7 Bay 24'-0" ⁴	8 Bay 27'-0" ⁴	8 Bay 27'-0" ⁴
	78" ³			2 Bay 9'-9" ⁴	3 Bay 12'-6" ⁴	3 Bay 12'-6" ⁴	4 Bay 15'-6" ⁴	5 Bay 18'-6" ⁴	7 Bay 24'-9" ⁴	8 Bay 27'-0" ⁴	8 Bay 27'-0" ⁴
X-wide	84" ³				3 Bay 13'-0" ⁴	3 Bay 13'-0" ⁴	4 Bay 15'-9" ⁴	5 Bay 18'-6" ⁴	7 Bay 24'-0" ⁴	8 Bay 27'-3" ⁴	8 Bay 27'-3" ⁴
	90" ³				3 Bay 13'-0" ⁴	3 Bay 13'-0" ⁴	4 Bay 15'-9" ⁴	5 Bay 18'-9" ⁴	7 Bay 24'-3" ⁴	8 Bay 27'-0" ⁴	8 Bay 27'-0" ⁴
	96" ³				3 Bay 12'-9" ⁴	3 Bay 12'-9" ⁴	4 Bay 16'-3" ⁴	5 Bay 18'-9" ⁴	7 Bay 24'-3" ⁴	8 Bay 27'-0" ⁴	8 Bay 27'-0" ⁴
	102"									8 Bay 27'-0" ⁴	8 Bay 27'-0" ⁴

- Note:
1. Design table applicable to permanent and temporary installations of compressive barriers
 2. Can be used in construction zones to shield the end of construction barrier curb or other obstruction up to 36 inches wide.
 3. Width = distance between end panels at backup.
 4. Length = Approximate distance from nose to back of end panel. The lengths listed are for Compact and Wide Flange backstops. Overall system lengths for other backstops will vary slightly

Table 9-5											
QuadGuard Elite ¹											
Width		Design Speed (mph), No. Bays, Length									
		Type 2					Type 3			Type 4	
		25	30	35	40	45	50	55	60	65	70
Narrow	24" ² ,	5 Bay 17'-11" ³	5 Bay 17'-11" ³	5 Bay 17'-11" ³	7 Bay 23'-10" ³	7 Bay 23'-10" ³	8 Bay 26'-7" ³	8 Bay 26'-7" ³	11 Bay 35'-6" ³	14 Bay 44'-9" ³	14 Bay 44'-9" ³
	30" ²	5 Bay 17'-11" ³	5 Bay 17'-11" ³	5 Bay 17'-11" ³	7 Bay 23'-10" ³	7 Bay 23'-10" ³	8 Bay 26'-7" ³	8 Bay 26'-7" ³	11 Bay 35'-6" ³	14 Bay 44'-9" ³	14 Bay 44'-9" ³
Medium	36" ²	5 Bay 17'-11" ³	5 Bay 17'-11" ³	5 Bay 17'-11" ³	7 Bay 23'-10" ³	7 Bay 23'-10" ³	8 Bay 26'-7" ³	8 Bay 26'-7" ³	11 Bay 35'-6" ³	14 Bay 44'-9" ³	14 Bay 44'-9" ³
Wide	69" ²	5 Bay 17'-11" ³	5 Bay 17'-11" ³	5 Bay 17'-11" ³	7 Bay 23'-10" ³	7 Bay 23'-10" ³	8 Bay 26'-7" ³	8 Bay 26'-7" ³	11 Bay 35'-6" ³	See Note 4	See Note 4
X-Wide	90" ²	5 Bay 17'-11" ³	5 Bay 17'-11" ³	5 Bay 17'-11" ³	7 Bay 23'-10" ³	7 Bay 23'-10" ³	8 Bay 26'-7" ³	8 Bay 26'-7" ³	11 Bay 35'-6" ³	See Note 4	See Note 4

- Note:
1. Design table applicable to permanent installations of low maintenance compressive barriers only
 2. Width = distance between fender panels at rear of crash cushion
 3. Length = Approximate distance from front of crash cushion to back of unit, including tension strut backup.
 4. Since a 14 bay unit is not available in either a 69" or 90" system width, an 11 bay unit may be used. The QuadGuard Elite has been successfully crash tested to NCHRP Report 350 or MASH and is considered to be compliant and sufficient for design speeds greater than 60 mph.

Table 9-6											
REACT 350 & REACT 350 II ¹											
Width		Design Speed (mph), No. Bays, Length									
		Type 2 ²					Type 3 ³			Type 4 ³	
		25	30	35	40	45	50	55	60	65	70
Medium ⁶	36" ⁴	4 Bay 14'-2" ⁵	4 Bay 14'-2" ⁵	4 Bay 14'-2" ⁵	4 Bay 14'-2" ⁵	4 Bay 14'-2" ⁵	6 Bay 20'-2" ⁵	6 Bay 20'-2" ⁵	6 Bay 20'-2" ⁵	6 Bay ⁷ 20'-2" ⁵	6 Bay ⁷ 20'-2" ⁵

- Note:
1. Design table applicable to permanent installations of low maintenance compressive barriers
 2. REACT 350
 3. REACT 350 II
 4. Width = outside diameter of cylinder
 5. Length = Approximate distance from face of front cylinder to obstruction. Add 3" for concrete backup with unidirectional traffic, and 9" for concrete backup with bidirectional traffic.
 6. Although wider REACT 350 units are available, due to the expense of these units, only the medium width is recommended for used on Department projects.
 7. The REACT 350 and REACT 350 II have been successfully crash tested to NCHRP Report 350 or MASH and are considered to be compliant and sufficient for design speeds greater than 60 mph.

Table 9-7											
QuadGuard II CZ ¹											
Width		Design Speed (mph), No. Bays, Length									
		Type 2					Type 3			Type 4	
		25	30	35	40	45	50	55	60	65	70
Narrow	24" ² ,	2 Bay 9'-11" ³	2 Bay 9'-11" ³	2 Bay 9'-11" ³	2 Bay 9'-11" ³	3 Bay 12'-11" ³	3 Bay 12'-11" ³	4 Bay 16'-0" ³	5 Bay 19'-0" ³	6 Bay 22'-0" ³	8 Bay 29'-1" ³
	30" ²	2 Bay 9'-11" ³	2 Bay 9'-11" ³	2 Bay 9'-11" ³	2 Bay 9'-11" ³	3 Bay 12'-11" ³	3 Bay 12'-11" ³	4 Bay 16'-0" ³	5 Bay 19'-0" ³	6 Bay 22'-0" ³	8 Bay 29'-1" ³
Medium	36" ² ,	2 Bay 9'-11" ³	2 Bay 9'-11" ³	2 Bay 9'-11" ³	2 Bay 9'-11" ³	3 Bay 12'-11" ³	3 Bay 12'-11" ³	4 Bay 16'-0" ³	5 Bay 19'-0" ³	6 Bay 22'-0" ³	8 Bay 29'-1" ³
	48" ²	2 Bay 9'-11" ³	2 Bay 9'-11" ³	2 Bay 9'-11" ³	2 Bay 9'-11" ³	3 Bay 12'-11" ³	3 Bay 12'-11" ³	4 Bay 16'-0" ³	5 Bay 19'-0" ³	6 Bay 22'-0" ³	8 Bay 29'-1" ³

- Note:
1. Design table applicable to temporary installations of compressive barriers only
 2. Width = distance between fender panels
 3. Length = Approximate distance from nose to rear of steel backup

Table 9-8											
REACT 350 WZ ¹ & REACT 350 II WZ											
Width		Design Speed (mph), No. Bays, Length									
		Type 2 ³					Type 3 ⁴			Type 4 ⁴	
		25	30	35	40	45	50	55	60	65	70
Medium	36" ²	4 Bay 13'-9" ⁵	4 Bay 13'-9" ⁵	4 Bay 13'-9" ⁵	4 Bay 13'-9" ⁵	4 Bay 13'-9" ⁵	6 Bay 21'-3" ⁵	6 Bay 21'-3" ⁵	6 Bay 21'-3" ⁵	6 Bay ⁶ 21'-3" ⁵	6 Bay ⁶ 21'-3" ⁵

- Note:
1. Design table applicable to temporary installations of low maintenance compressive barriers only
 2. Width = outside diameter of cylinder
 3. REACT 350 WZ
 4. REACT 350 II WZ
 5. Length = Approximate distance from face of front cylinder to rear of steel self-contained backup.
 6. The REACT 350 and REACT 350 II have been successfully crash tested to NCHRP Report 350 or MASH and are considered to be compliant and sufficient for design speeds greater than 60 mph.

9.2.4 Geometrics of the Site

The vertical and horizontal alignment, especially curvature of the road and sight distance, are important factors to be considered. Adverse geometrics could contribute to a higher than normal frequency of impacts.

9.2.5 Physical Conditions of the Site

The presence of a curb can seriously reduce the effectiveness of a crash cushion. It is recommended that all curbs and islands be removed approximately 50 feet in front of a crash cushion and as far back as the unit's backup. While new curbs should not be built where crash cushions are to be installed, it is not essential to remove existing curbs less than four inches in height. Curbs from four inches to six inches in height should be removed unless consideration of the curb shape, site geometry, impending overlays that would reduce the curb height, and cost of removal justify leaving the curb in. Curbs over six inches high shall be removed before installing a crash cushion. When a curb is terminated behind a crash cushion, the curb should be gently flared and/or ramped. Flares of 15:1 and ramps of 20:1 are recommended on high speed facilities.

Where a crash cushion is to be installed on the end of a median barrier at an intersection, locate the end of the median barrier based upon the longest crash cushion that could be used at the intersection. The designer shall provide stations for the beginning and end of median barrier curb at the intersection.

Crash cushions should be placed on a relatively flat surface. Longitudinal and transverse slopes in excess of 8 percent could adversely affect the performance of a crash cushion and should be avoided. If the cross slope varies more than 2 percent over the length of the unit, a concrete leveling pad or other compensating alterations may have to be made at the site.

Joints, especially expansion joints, in the crash cushion area may require special design accommodations for those crash cushions that require anchorage. The designer should contact the manufacturer/supplier before proceeding with a crash cushion design that spans an expansion joint(s).

9.2.6 Redirection Characteristics

Compressive barriers have redirection capabilities. Since inertial barriers have no redirection capabilities, it is important that the recommended placement details shown in Figure 9-B be adhered to so as to minimize the danger of a vehicle penetrating the barrier from the side and hitting the obstructions.

9.2.7 Design Speed

Compressive barriers and inertial barrier systems can be designed for speeds up to 70 mph.

9.2.8 Foundations

Permanent inertial barriers shall be placed on concrete or asphalt pavement that is four inches or greater in thickness. Temporary inertial barriers may be placed on any smooth compacted surface. Permanent QuadGuard II, QuadGuard Elite, REACT 350 and REACT 350 II Systems must be installed on existing concrete pavement or a concrete pad. A concrete foundation is also required for permanent SCI, Universal TAU-II and TRACC systems. All temporary compressive barriers may be placed on HMA, HMA over concrete or HMA over DGA. Table 9-9 lists the minimum foundation requirements for the various compressive barrier systems.

In addition to the permanent foundation types indicated in Table 9-9 for the Universal TAU II, it may also be installed on a 4" minimum non-reinforced concrete pad or 6" HMA over a 6" DGA base pad. However, this will require the construction of a reinforced anchor block 48" wide x 36" deep x 33.5" long at the front of the pad when using a portable concrete barrier backstop anchored directly to an existing or proposed concrete barrier curb or wall. If a compact backstop is used, a reinforced anchor block 48" wide x 36" deep x 33.5" long will be required at the front of the pad and an anchor block 48" wide x 36" deep x 47" long will be required at the back of the pad.

When the QuadGuard II or QuadGuard Elite with a tension strut backup is installed on a 6" reinforced concrete pad, an anchor block 48" long x 30" deep x 48" wide at the front of the pad is required. The anchor block is not required if these units are installed on an 8" reinforced concrete pad. For the QuadGuard II with a concrete backup, a footing 24" long x 36" deep x 48" wide is required and is to be poured monolithically with the backup.

For an independent installation, the REACT 350 and REACT 350 II with a self-contained backup requires an anchor block to be poured monolithically with the concrete pad. The anchor block is 54" wide x 28" deep x 24" long for unidirectional traffic and 30" long for bidirectional traffic at the rear of the concrete pad. However, if the system is to be placed against and supported by a rigid barrier or other structure, the anchor block may be omitted.

To avoid conflicts, the designer should avoid placing drainage systems or subsurface utilities within the foundation area of compressive barrier systems.

Table 9-9					
Compressive Barrier System	Minimum Foundation Requirements				
	Permanent and Temporary Installations		Temporary Installation		
	Existing Concrete ¹	Concrete Pad ²	HMA Only	HMA over Concrete	HMA & DGA
QuadGuard II	6" reinforced, 8" nonreinforced	6" reinforced 8" reinforced ³	NA	NA	NA
QuadGuard II CZ	6" reinforced, 8" non-reinforced	6" reinforced	8"	3" HMA 3" Concrete	6" HMA 6" DGA
QuadGuard Elite	6" reinforced, 8" non-reinforced	6" reinforced 8" reinforced ³	NA	NA	NA
REACT 350 REACT 350 II	8" reinforced, 8" non-reinforced	8" reinforced	NA	NA	NA
REACT 350WZ REACT 350 II WZ	8" reinforced, 8" non-reinforced	8" Precast reinforced ⁴	8"	3" HMA 3" Concrete	6" HMA 6" DGA
SCI	6" reinforced 8" non-reinforced	6" reinforced 8" non- reinforced	8"	3" HMA 3" non- reinforced	6" HMA 6" DGA
TRACC	6" reinforced, 8" non-reinforced	6" reinforced 8" non- reinforced	8"	3" HMA 3" Concrete	6" HMA 6" DGA
Universal TAU-II	6" reinforced, 8" non-reinforced	6" reinforced 8" non- reinforced	8"	3" HMA 3" Concrete	6" HMA 6" DGA

HMA = Hot Mix Asphalt

DGA = Dense Graded Aggregate Base Course

- Note:
1. Minimum concrete pavement dimensions are 12 feet wide by 50 feet long.
 2. The dimensions of the concrete pad are available from the manufacturers.
 3. Optional concrete pad for tension strut backup. To prevent sliding during an impact, the concrete pad must be installed against or tied to an existing structure otherwise additional below grade supports must be added.
 4. 36" wide, 4-bay system only

9.2.9 Backup Structure Requirements

Inertial Barriers do not require a backup structure.

Several compressive crash cushions have more than one type of backup structure that is capable of withstanding the forces of an impact. Backup systems and detailed drawings are available from the manufacturer/supplier (see Subsection 9.4 for contact information).

Table 9-10 lists the backup systems for various compressive crash cushions.

Table 9-10	
BACKUP STRUCTURES	
Crash Cushion	Backup Structure ¹
QuadGuard II	Tension Strut Backup ² Concrete Backup ²
QuadGuard Elite	Tension Strut Backup ²
QuadGuard II CZ	Steel Backup ²
REACT 350	Steel Self-Contained Backup ⁴ Concrete Backup ⁵
REACT 350WZ	Steel Self-Contained Backup ⁴
Universal TAU-II	Compact Backstop ^{2,3} Compact Backstop with Asphalt Adapter ^{2,3} Portable Concrete Barrier Backstop ^{2,3} Portable Concrete Barrier Backstop with Asphalt Adapter ^{2,3} Flush Mount ^{2,3} Wide Flange Backstop ⁶
TRACC	W-beam median barrier, thrie beam median barrier, vertical concrete wall or concrete barrier curb ⁷
SCI	Self-supporting, does not require backup structure 2

- Note:
1. Where there is a choice of backstops, the designer shall contact the manufacturer/supplier to determine the appropriate backstop to use for each site.
 2. Provision shall be made for rear side panels to move rearward beyond the back of the crash cushion a minimum of 2.5 ft. on impact.
 3. Must be attached directly to the end of a concrete barrier
 4. Where used to shield barrier curb, the base of the barrier curb must be tapered, see manufacturer's recommendations. Include the tapered requirements in GENERAL NOTES on the applicable construction detail (CD-611-1 or CD-159-10).
 5. Where used to shield barrier curb, a 10' barrier curb transition shall be provided to avoid the backup from protruding beyond the barrier curb where traffic will be approaching from the rear of the system. Include the taper requirement in the GENERAL NOTES on the applicable construction detail (CD-611-1 or CD-159-10).
 6. Required for systems 42" wide and greater
 7. 5 ft. clear space required on both sides of the backup structure for the side panels to retract during an end-on impact

9.2.10 Anchorage Requirements

Compressive barrier systems require an anchorage that is capable of restraining the crash cushion during an impact. The manufacturers' standard designs of these crash cushions include the necessary anchorage.

9.2.11 Flying Debris Characteristics

Impact with an inertial barrier will produce some flying debris. However, this is not considered a serious drawback.

9.2.12 Initial Cost

The inertial barriers have the lowest initial cost. Compared to inertial barriers, the compressive barrier systems have the highest initial cost. Assuming the same site preparation requirements, the initial cost of a compressive barrier system will

usually be five to six times higher than an inertial barrier. The initial cost of the QuadGuard Elite, REACT 350 and REACT 350 II Systems is significantly higher than the standard compressive barrier systems. However, due to their reusability after a crash, the cost to maintain these systems is much less than the QuadGuard II, TRACC and the Universal TAU II.

9.2.13 Maintenance

Inertial barriers are particularly susceptible to damage during minor impacts. Because of their susceptibility to damage, permanent inertial barriers should not be used in gore areas unless the width of the obstruction cannot be shielded by a compressive barrier. In addition, at locations where nuisance hits may be common or there is a high probability of accidents, a compressive barrier should be considered in lieu of the inertial barrier as a means of reducing maintenance requirements.

Compressive barrier systems are generally reusable after a minor collision. After a severe impact, the QuadGuard II and Universal TAU-II Cartridges must be replaced after the units are repositioned and other damaged components replaced. The TRACC system may be permanently twisted after a severe impact. If one side of the system is raised more than 1 ½ inches when compared to the other side of the system, then the damaged base assembly should be replaced in addition to other damaged components. The SCI after most frontal impacts has only minor damage and generally no repairs are required after a side impact. Repairs can typically be made within one hour.

For most impacts with the QuadGuard Elite, REACT 350 and REACT 350 II Systems, the main structural elements and energy absorbing materials do not require replacement. The unit is reusable after most impacts and can generally be placed back into service in approximately one hour.

9.3 Design Procedure

9.3.1 Inertial Barriers

Inertial barriers on the Qualified Products List (QPL) are interchangeable in any array. The design of an inertial barrier is based on the law of conservation of momentum. It can be shown that:

Equation 1
$$V_f = \frac{W V_o}{W + W_s}$$

V_f = velocity of vehicle after impact with W_s , in fps

V_o = velocity of vehicle prior to impact with W_s , in fps

W = weight of vehicle, in lbs

W_s = weight of sand actually impacted by a 6-foot wide vehicle, in lbs.

This equation is used to calculate the velocity of a vehicle as it penetrates each row of the inertial barrier. When a vehicle has been slowed to approximately 10 mph (14.7 fps) or less per Equation 1, it will actually have been stopped because of deceleration forces that have been neglected in Equation 1.

Slowing of the vehicle must take place gradually so that the desirable deceleration force is 6G's for unrestrained occupants, and 8G's with lap belt in place. Where space is limited, a maximum of 12G's should be used. The deceleration force is calculated using Equation 2. Note that velocity is in feet per second (fps).

Equation 2

$$G = \frac{V_o^2 - V_f^2}{2Dg}$$

G = deceleration force in G's

V_o = velocity of vehicle prior to impact, in fps

V_f = velocity of vehicle after impact with one row of modules, in fps

D = distance traveled in decelerating from V_o to V_f

(Usually D = width of a module = 3 feet)

g = 32.2 ft/s²

The standard weights of modules used are 200 lbs., 400 lbs., 700 lbs., 1400 lbs., and 2100 lbs. However, the use of a 2100 lbs. module is not recommended unless site conditions are restricted and the use of 1400 lbs. modules would not stop the vehicle from striking the obstruction.

A minimum of two modules are required in the last three rows of the barrier array to meet the 2.5 feet criteria shown in Figure 9-B. An additional last row of 1400 lbs. modules is provided after required reduction in speed is obtained.

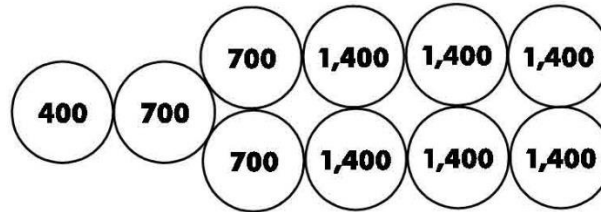
When a wide obstruction is being shielded, the modules may be spaced up to 3 feet apart. However, module to module spacing greater than 6 inches must be accounted for in the design. W_s in Equation 1 is the weight of sand impacted by a 6-foot wide vehicle. Therefore, if 1400 lbs. modules (three feet diameter) were spaced 2 feet apart, W_s would equal 1867 lbs.

Sand barrel arrays can be designed for any speed up to 60 mph. On projects that have design speeds exceeding 60 mph, the sand barrel array shall be designed for 60 mph. The Energite III, Universal and Big Sandy Inertial Barriers have been successfully crash tested to NCHRP Report 350 or MASH and are considered to be compliant and sufficient for design speeds greater than 60 mph.

Figures 9-D, 9-E and 9-F illustrate typical sand barrel configurations for narrow barrier arrays.

The designer should first check the sand barrel configuration for an 1800 lb. vehicle and then make the same check for a 4400 lb. vehicle. Using Figure 9-F with a design speed of 60 mph (88 fps) as an example:

**FIGURE 9-D:
TYPICAL SAND BARREL CONFIGURATION**



40 MPH DESIGN - 4,400# VEHICLE

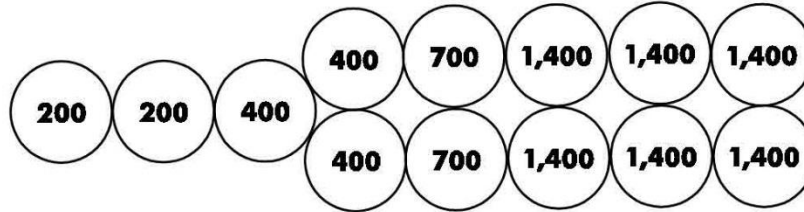
ROW	Ws (LB)	V _o	V _f	G
1	400	58.7	53.8	2.8
2	700	53.8	46.4	3.8
3	1,400	46.4	35.2	4.7
4	2,800	35.2	21.5	4.0
5	2,800	21.5	13.1	1.5
6	2,800	—	—	—

40 MPH DESIGN - 1,800# VEHICLE

ROW	Ws (LB)	V _o	V _f	G
1	400	58.7	48.0	5.9
2	700	48.0	34.6	5.7
3	1,400	34.6	19.5	4.2
4	2,800	19.5	7.6	1.7
5	2,800	—	—	—
6	2,800	—	—	—

REV. DATE: JUNE 30, 2015

**FIGURE 9-E:
TYPICAL SAND BARREL CONFIGURATION**



50 MPH DESIGN - 4,400# VEHICLE

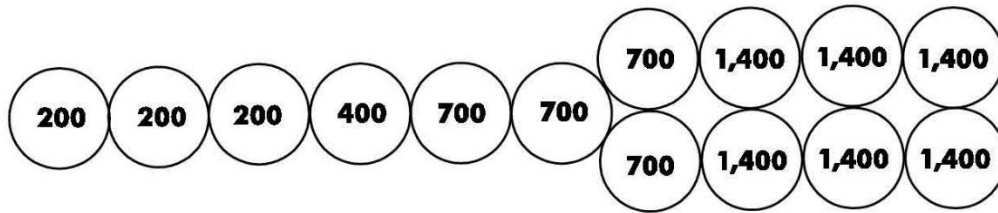
ROW	Ws (LB)	V _o	V _f	G
1	200	73.3	70.1	2.4
2	200	70.1	67.1	2.2
3	400	67.1	61.5	3.7
4	800	61.5	52.0	5.6
5	1,400	52.0	39.5	6.0
6	2,800	39.5	24.1	5.1
7	2,800	24.1	14.7	1.9
8	2,800	—	—	—

50 MPH DESIGN - 1,800# VEHICLE

ROW	Ws (LB)	V _o	V _f	G
1	200	73.3	66.0	5.3
2	200	66.0	59.4	4.3
3	400	59.4	48.6	6.0
4	800	48.6	33.6	6.4
5	1,400	33.6	18.9	4.0
6	2,800	18.9	7.4	1.6
7	2,800	—	—	—
8	2,800	—	—	—

REV. DATE: JUNE 30, 2016

**FIGURE 9-F:
TYPICAL SAND BARREL CONFIGURATION**



60 MPH DESIGN - 4,400# VEHICLE

ROW	Ws (LB)	V _o	V _f	G
1	200	88.0	84.2	3.4
2	200	84.2	80.5	3.1
3	200	80.5	77.0	2.9
4	400	77.0	70.6	4.9
5	700	70.6	60.9	6.6
6	700	60.9	52.5	4.9
7	1,400	52.5	39.9	6.1
8	2,800	39.9	24.4	5.2
9	2,800	24.4	14.9	1.9
10	2,800	—	—	—

60 MPH DESIGN - 1,800# VEHICLE

ROW	Ws (LB)	V _o	V _f	G
1	200	88.0	79.2	7.6
2	200	79.2	71.3	6.2
3	200	71.3	64.2	5.0
4	400	64.2	52.5	7.1
5	700	52.5	37.8	6.9
6	700	37.8	27.2	3.6
7	1,400	27.2	15.3	2.6
8	2,800	15.3	6.0	1.0
9	2,800	—	—	—
10	2,800	—	—	—

REV. DATE: JUNE 30, 2015

**Example of Inertial Barrier Design
for 1800 lb. Vehicle:**

ROW	W_s	V_o	V_f^1	$G^{1, 2}$
1	200	88	79.2	7.6
2	200	79.2	71.3	6.2
3	200	71.3	64.2	5.0
4	400	64.2	52.5	7.1
5	700	52.5	37.8	6.9
6	700	37.8	27.2	3.6
7	1400	27.2	15.3	2.6
8	2800	15.3	6.0	1.0
9	2800	---	---	---
10	2800	---	---	---

Note 1 V_f and G are calculated using Equations 1 & 2.

Note 2 It is desirable to limit G for each row to a maximum of 6. However, since 200 lbs. is the lightest module recommended for use, the 7.6 cannot be decreased.

**Example of Inertial Barrier Design
for 4400 lb. Vehicle:**

ROW	W_s	V_o	V_f^1	G^1
1	200	88	84.2	3.4
2	200	84.2	80.5	3.1
3	200	80.5	77.0	2.9
4	400	77.0	70.6	4.9
5	700	70.6	60.9	6.6
6	700	60.9	52.5	4.9
7	1400	52.5	39.9	6.1
8	2800	39.9	24.4	5.2
9	2800	24.4	14.9	1.9
10	2800	---	---	---

Note 1 V_f and G are calculated using Equations 1 & 2.

Since the assumed configuration (shown in Figure 9-F) meets all the requirements specified in the previous examples, no changes are necessary.

Although manufacturers of inertial barriers have developed designs for various speeds, designers shall develop barrier arrays based upon the previous examples.

A layout of the modules, including the weight of each module, must be included as a construction detail in the contract plans.

9.3.2 Compressive Barriers

The standard items for compressive barriers are generic.

There are two different types of standard items for permanent compressive barriers contained in the current Section 611 of the 2007 Standard Specifications for Road and Bridge Construction:

- CRASH CUSHION, COMPRESSIVE BARRIER, TYPE __, WIDTH _____
- CRASH CUSHION, LOW MAINTENANCE COMPRESSIVE BARRIER, TYPE __, WIDTH _____

There are also two different types of standard items for temporary compressive barriers contained in the current Section 159 of the 2007 Standard Specifications for Road and Bridge Construction:

- TEMPORARY CRASH CUSHION, COMPRESSIVE BARRIER, TYPE __, WIDTH _____
- TEMPORARY CRASH CUSHION, LOW MAINTENANCE COMPRESSIVE BARRIER, TYPE __, WIDTH _____

Each standard item is divided by TYPE:

- TYPE 2= Design Speed of 45 MPH or less
- TYPE 3= Design Speed of 50 to 60 MPH
- TYPE 4 = Design Speed of 65 to 70 MPH

Each standard item is further divided by WIDTH:

- NARROW= 24" to 30"
- MEDIUM= >30" to 48"
- WIDE= >48" to 72"
- X-WIDE= >72" to 120"

Determine which standard item to use along with the type and width to fit your site. Examples of item names would be:

- CRASH CUSHION, COMPRESSIVE BARRIER, TYPE 3, WIDTH NARROW
- CRASH CUSHION, LOW MAINTENANCE COMPRESSIVE BARRIER, TYPE 2, WIDTH MEDIUM
- TEMPORARY CRASH CUSHION, COMPRESSIVE BARRIER, TYPE 4, WIDTH NARROW
- TEMPORARY CRASH CUSHION, LOW MAINTENANCE COMPRESSIVE BARRIER, TYPE 3, WIDTH X-WIDE

Since the item names are generic, the designer will need to determine which of the approved crash cushion models and sizes will fit each site and list them on the appropriate Crash Cushion Compressive Barrier Summary Table in the Standard Roadway Construction Details. The contractor will use the information provided by the designer in these summary tables as a basis for their bid. Follow the guidance below to properly fill in these tables.

The designer should determine which of the approved crash cushion models will fit at each site, based on the dimensions of the obstruction being protected (see subsection 9.2.2) and the space requirements of the crash cushion (see subsection 9.2.3). Subsection 9.2.1 B, C, D and E list the approved models and Table 9-1 through 9-8 list the model sizes based on TYPE, WIDTH and design speed. Unless there is a space limitation at a site, any one of the approved crash cushions may be used. Therefore, the designer must determine which compressive crash cushion model(s)/size(s) will fit at each location.

After determining which models and sizes will physically fit each site, the designer should further narrow down the list of potential models/sizes by evaluating the remaining factors contained in subsection 9.2.4 through 9.2.13. There is therefore no simple, systematic selection procedure.

The final list of potential models/sizes should include all those deemed appropriate for the site. The designer then must provide the Item Number, Pay Item, Description, Design Speed, Product information, Route and Station, Foundation and Backup System information in the Standard Roadway Construction Details. In addition, information specific to the model(s) selected, such as required barrier transitions, system offsets, anchor blocks, etc. shall be included in the GENERAL NOTES on the applicable construction detail (CD-159-10 or CD-611-1). The designer shall enter the information for temporary compressive crash cushions and temporary low maintenance crash cushions on the Temporary Crash Cushion Compressive Barrier Summary Table in Construction Detail CD-159-10 for all the crash cushion models/sizes that the contractor may use for that site. The designer shall enter the information for permanent compressive crash cushions and permanent low maintenance crash cushions on the Crash Cushion Compressive Barrier Summary Table in Construction Detail CD-611-1 for all the crash cushion models/sizes that the contractor may use for that site. Figure 9-G and Figure 9-H are examples of the Temporary Crash Cushion Compressive Barrier Summary Table and Crash Cushion Compressive Barrier Table respectively.

**FIGURE 9-G:
EXAMPLE TEMPORARY CRASH CUSHION
COMPRESSIVE BARRIER SUMMARY TABLE**

TEMPORARY CRASH CUSHION COMPRESSIVE BARRIER SUMMARY TABLE						
ITEM NO.	DESCRIPTION	DESIGN SPEED	ROUTE AND STATION	PRODUCT	FOUNDATION	BACKUP SYSTEM
159200	TEMPORARY CRASH CUSHION, COMPRESSIVE BARRIER TYPE 2, WIDTH NARROW	40 MPH	ROUTE 130, PROPOSED BASELINE STATION 1500+00 RT.	QUADGUARD II CZ 2 BAY, 24" WIDE 9'-11" LENGTH	EXISTING PAVEMENT	TENSION STRUT
				TAU II, 4 BAY, 30" WIDE 15'-9" LENGTH	EXISTING PAVEMENT	CONCRETE BACKSTOP WITH ASPHALT ADAPTER
				SHORTRACC, 24" WIDE 14'-3" LENGTH	EXISTING PAVEMENT	NA
				SCI 70GM, 24" WIDE 13'-6" LENGTH	EXISTING PAVEMENT	NA

GENERAL NOTES:

1. FOR EACH LOCATION SHOWN IN THE TEMPORARY CRASH CUSHION, COMPRESSIVE BARRIER SUMMARY TABLE, INSTALL ONE (1) OF THE CRASH CUSHIONS LISTED FOR THAT LOCATION.
2. THE STATION LOCATION SHOWN IS APPROXIMATE AND MAY BE ADJUSTED IN THE FIELD.

REV. DATE: JUNE 30, 2015

**FIGURE 9-H:
EXAMPLE CRASH CUSHION COMPRESSIVE BARRIER
SUMMARY TABLE**

CRASH CUSHION COMPRESSIVE BARRIER SUMMARY TABLE						
ITEM NO.	DESCRIPTION	DESIGN SPEED	ROUTE AND STATION	PRODUCT	FOUNDATION	BACKUP SYSTEM
611312	CRASH CUSHION, COMPRESSIVE BARRIER TYPE 3, WIDTH NARROW	50 MPH	ROUTE 130, PROPOSED BASELINE STATION 1450+50 LT.	QUADGUARD II 3 BAY, 24" WIDE 12'-11" LENGTH	8" REINFORCED CONCRETE PAD	TENSION STRUT
				TAU II, 5 BAY, 30" WIDE 18'-6" LENGTH	6" REINFORCED CONCRETE PAD	COMPACT BACKSTOP
				TRACC, 24" WIDE 21'-3" LENGTH	6" REINFORCED CONCRETE PAD	NA
611315	CRASH CUSHION, COMPRESSIVE BARRIER TYPE 3, WIDTH MEDIUM	60 MPH	ROUTE 130, PROPOSED BASELINE STATION 1600+00 RT.	SCI 100 GM, 24" WIDE 21'-6" LENGTH	6" REINFORCED CONCRETE PAD	NA
				QUADGUARD II 5 BAY, 36" WIDE 19'-0" LENGTH	6" REINFORCED CONCRETE PAD (SEE NOTE 2)	TENSION STRUT
				TAU II, 8 BAY, 36" WIDE 27'-0" LENGTH	6" REINFORCED CONCRETE PAD	COMPACT BACKSTOP
				WIDE TRACC, 41" WIDE 21' LENGTH	6" REINFORCED CONCRETE PAD	NA

GENERAL NOTES:

- FOR EACH LOCATION SHOWN IN THE CRASH CUSHION, COMPRESSIVE BARRIER SUMMARY TABLE, INSTALL ONE (1) OF THE CRASH CUSHIONS LISTED FOR THAT LOCATION.
- ANCHOR BLOCK REQUIRED UNDER FRONT OF CONCRETE PAD. CONTACT MANUFACTURERSUPPLIER FOR DETAILS.

REV. DATE: JUNE 30, 2015

The following are instruction for filling out the summary tables:

1. The first column on the left side of the table is labeled "ITEM NO." Place the standard item number chosen for the first site (IE: 611312). The list of Item numbers are updated as needed and made available on the New Jersey Department of Transportation web page, Doing Business, Trns*port Software, Cost Estimation at <http://www.nj.gov/transportation/business/trnsport/estimation.shtm>. The temporary compressive crash cushions are in the 159200 item number series and the permanent compressive crash cushions are in the 611300 item number series.
2. The second column from the left side of the table is labeled "DESCRIPTION". Place the description of the item number chosen (IE: CRASH CUSHION, COMPRESSIVE BARRIER, TYPE 3, WIDTH NARROW). Use the descriptions shown in the web site list referenced above.
3. The third column from the left side of the table is labeled "DESIGN SPEED". Place the design speed for the first site (IE: 50 MPH).
4. The fourth column from the left side of the table is labeled "ROUTE & STATION". Place the Route name that the first site is on. If it is on a ramp, name the ramp as it appears on the plans. Then identify which baseline you are using, the station location and the side it is on (IE: ROUTE 130 PROPOSED BASELINE STATION 1450+50 LT.) For temporary crash cushions, the station is approximate:
5. The fifth column from the left side of the table is labeled "PRODUCT". This is the final list of models and sizes that fit this site. The Product information shall include the product name, number of bays (if applicable), width and length. For example:

QUADGUARD II

3 BAY

24" WIDE

12'-11" LONG

UNIVERSAL TAU II

5 BAY

30" WIDE

18'-6" LONG

TRACC

24" WIDE

21'-3" LONG

SCI 100 GM

24" WIDE

21'-6" LONG

In the example above, the first site had an obstruction 2' wide and an available length of crash cushion reserve area of 25 feet. In this example, all 4 compressive crash cushion products fit the site. If the available length of crash cushion reserve area was only 19 feet long, only the top 2 products listed above would have fit the site.

6. The sixth column from the left side of the table is labeled "FOUNDATION". Place the foundation type for each of the models at the first site, see Section 9.2.9 and Table 9-9. For example, the QUADGUARD II and SCI 100 GM are using a "concrete pad."
7. The seventh and final column from the left side of the table is labeled "BACKUP SYSTEM". Place the backup system for each of the models at the first site, see Section 9.2.10 and Table 9-10. For example, the QUADGUARD II is using the "tension strut"; and SCI 100 GM does not require a backup system, therefore enter "NA". Standard designs for backup structures are available from the manufacturer.
8. Continue to fill out the summary tables for the rest of your project sites, follow steps 1 thru 7 above. Attach the completed summary table construction detail(s) to the project plans.
9. On federally funded projects, when a site requires either a permanent or temporary crash cushion and there are less than 3 products that are available to fit the site, the designer will need to fill out a *Request for Approval of Patented/Proprietary Items on Federally Funded Projects* (Form DF-15). Prior to completing the said form, the designer must follow the instructions under subsection 106.09 of the Standard Input. A copy of the request form and Questions and Answers Regarding Public Interest Findings are included at the end of the section. The completed request shall be submitted to the Project Manager for his/her signature in Section F. The Project Manager shall submit the request to the appropriate FHWA Area Engineer at the following address:

FHWA – NJ Division, Division Administrator,
 Attention: "Area Engineer"
 840 Bear Tavern Road, Suite 202,
 West Trenton, NJ 08628.

To allow for sufficient lead time for FHWA review and approval, the designer should prepare and submit the request to the project manager as early as possible during the preparation of the Final Design.

On non-federally funded projects, the procedure models the procedure for FHWA projects except that the form for *Request for Approval of Patented/Proprietary Items On Non-FHWA Funded Contracts* (Form DF-16) must be completed in addition to following the instructions under subsection 106.09 of the Standard Input prior to completing the aforementioned form. The completed form will be submitted to the Project Manager for review and signature and his ultimate submittal to the Director of Capital Program Support for approval. A copy of the request form and Questions and Answers Regarding Waivers are included at the end of the section.

Electronic versions of the request forms DF-15 and DF-16 are also available at: <http://www.state.nj.us/transportation/eng/forms/index.shtml>.

In addition, for both federally funded and non-federally funded projects, designers must include the following text preceding the list of manufactures/suppliers in the appropriate subsection of the Special Provisions.

"The following manufactures/suppliers are capable of manufacturing/supplying the Item/material specified for this contract. This list is not intended to be a complete list of potential manufactures/suppliers."

9.4 Product Information

For additional information regarding the products contained in this section, the designer should contact the following manufacturers/suppliers:

Barrier Systems Inc. 1-888-800-3691

Universal TAU-II

SCI Products Inc. 1-800-327-4417

SCI

TraFFix Devices Inc. 1-949-361-5663

Big Sandy Inertial Barrier

Transpo Industries 1-914-636-1000

Energite III Inertial Barrier

QuadGuard II

QuadGuard CZ

QuadGuard Elite

REACT 350

REACT 350 WZ

Universal Inertial Barrier

Trinity Highway Products 1-800-321-2755

TRACC



FEDERAL HIGHWAY ADMINISTRATION
NEW JERSEY DIVISION



NEW JERSEY DEPARTMENT OF
TRANSPORTATION

REQUEST FOR APPROVAL OF PATENTED/PROPRIETARY ITEMS ON FEDERALLY FUNDED PROJECTS

Regulatory References: 23 CFR 635.411

Policy Guidance <http://www.fhwa.dot.gov/construction/cqit/propriet.cfm>

Federal funds shall not participate, directly or indirectly, in payment for any patented and proprietary material, specification, or process set forth in the plans and specifications for a project unless:

1. The patented or proprietary item is purchased or obtained through competitive bidding with 2 or more **equally** suitable unpatented items; or
2. The State certifies either the patented or proprietary item is essential for synchronization or no suitable alternative exists; or
3. The patented/proprietary item is used for research or for a distinctive type of construction on relatively short sections of road for experimental purposes; or
4. The State may require a specific material or product when there are other acceptable materials and products, when such specific choice is approved by the Division Administrator as being in the public interest.

Section A: STATE CERTIFIES

- Synchronization with existing facilities** (23 CFR 635.411 (a)(2)) (Provide reasoning in Section G)
- No suitable Alternative/Sole Source** (23 CFR 635.411 (a)(2)) (Provide reasoning in Section G)

Section B: STATE REQUESTS APPROVAL FOR

- Experimental or Research Purposes** (23 CFR 635.411 (a)(3)); (NOTE: If item is for research and experimental purposes then NJDOT, New Technologies & Products Unit (NTP), must submit a work plan and follow procedures outlined within FHWA's policy and guidance for "Construction Projects Incorporating Experimental Features".) (<http://www.fhwa.dot.gov/programadmin/contracts/expermnt.cfm>)
- Public Interest Finding** (23 CFR 635.411(c))

Section C: STATEWIDE OR SPECIFIC PROJECT DETERMINATION

Is the request to be used for 2 or more federally funded projects (Statewide/multiple projects)?	<input type="checkbox"/> Yes (If yes, then do not complete Section D. Proceed to Section E through Section H).	<input type="checkbox"/> No (If no, then proceed to Section D through Section H).
--	--	---

Section D: SPECIFIC PROJECT INFORMATION

Proj. Delivery (Process):	<input type="checkbox"/> Std. Scope Process	<input type="checkbox"/> Limited Scope Process	<input type="checkbox"/> Other Proj. Delivery Types: _____
Federal Project Number:	Project Description:		
UPC#:			
Route:			
Section:			
County:			

Section E: PRODUCT DESCRIPTION

(NOTE: Provide detailed information concerning the intended use of the product. Attach relevant product information as warranted.)

Section F: REASONS FOR REQUESTED APPROVAL

(NOTE: Justification should document engineering and economic considerations, product availability and compatibility, logistical concerns, and other unique considerations. The purpose is to document a finding of public interest. Attach supporting documentation as deemed appropriate by FHWA or State.)

Section G: REASONS FOR CERTIFICATION

Include a statement by the appropriate official attesting that the proprietary product is essential for synchronization with existing facilities; or that no equally suitable alternative exists (23 CFR 635.411(a)(2)). For further information on Certification language, see Q&A number D2 at the following link http://www.fhwa.dot.gov/programadmin/contracts/011106qa.cfm#_Hlk307506810.

For example:

“I (name of certifying official), (position title), of the (Name of contracting agency), do hereby certify that in accordance with the requirements of 23 CFR 635.411(a)(2), that this patented or proprietary item is essential for synchronization with existing highway facilities.”

or

“I (name of certifying official), (position title), of the (Name of contracting agency), do hereby certify that in accordance with the requirements of 23 CFR 635.411(a)(2), that no equally suitable alternative exists for this patented or proprietary item.”

Section H: SIGNATURE BLOCKS

FOR SECTION A:	NAME & TITLE	DATE:
FOR SECTION C:	NAME & TITLE	DATE:

Section I: TO BE COMPLETED BY FEDERAL HIGHWAY ADMINISTRATION (FHWA) ONLY (section B or C “Yes” requests only)

REMARKS (FHWA):		
SUNSET PROVISION REQUIRED:	<input type="checkbox"/> YES, IF SO, EXPIRATION DATE IS _____	<input type="checkbox"/> NO
APPROVED BY FHWA'S REPRESENTATIVE	RESPRESENTATIVE NAME & TITLE	DATE:

NOTE: According to Stewardship Agreement FHWA’s Signature is required for all FHWA funded contracts.



NEW JERSEY DEPARTMENT OF TRANSPORTATION REQUEST FOR APPROVAL OF PATENTED/PROPRIETARY ITEMS ON NON-FHWA FUNDED CONTRACTS

State funds are not to be participate, directly or indirectly, in payment for any patented and proprietary material, specification, or process set forth in the Plans and specifications for a contract unless:

1. The patented or proprietary item is purchased or obtained through competitive bidding with 2 or more **equally** suitable unpatented items; or
2. The Designer certifies either the patented or proprietary item is essential for synchronization or no suitable alternative exists; or
3. The patented/proprietary item is used for research or for a distinctive type of construction on relatively short sections of road for experimental purposes.

Section A: State Certifies And/Or Requests A Public Interest Determination For

<input type="checkbox"/>	Synchronization with existing facilities
<input type="checkbox"/>	No suitable Alternative/Sole Source
<input type="checkbox"/>	Experimental or Research Purposes
<input type="checkbox"/>	Other (explain)

Section B: Specific Contract Information

DP#:		Project Description:
Route:		
Section:		
County:		

Section C: Product Description

(NOTE: Provide detailed information concerning the intended use of the product. Attach relevant product information as warranted.)

Section D: Reason for Request Approval

Section E: Signature Blocks

Section F: Completed by Management

Questions and Answers Regarding Public Interest Findings

Reference: FHWA Contract Administration Questions & Answers

(<http://www.fhwa.dot.gov/programadmin/contracts/011106qa.cfm>)

"The FHWA regulation in 23 CFR 635.411, "Material or product selection," prohibits the expenditure of Federal-aid funds on a Federal-aid highway project "for any premium or royalty on any patented or proprietary material, specification, or process" (referred to hereafter as "proprietary product"), unless specific conditions are met. This regulation is intended to ensure competition in the selection of materials, products, and processes while also allowing the opportunity for innovation where there is a reasonable potential for improved performance."

1. What is a proprietary product?

Generally, this is a product, specification, or process identified in the plans or specifications as a "brand" or trade name (e.g. 3M, Corten). However, it may also be a product so narrowly specified that only a single provider can meet the specification.

2. Are patented products considered proprietary?

Yes, if the patented product is identified within the plans or specifications as a "brand" or trade name; or the specification is written so that only the patented product can meet the specification.

3. If the patent of a product expires, does the State DOT still need to certify and/or request to utilize the product for the product to be considered a federally participating expense?

Depends upon the situation. If the patent expires but the product's name is identified within the plans and specifications without 2 or more equally suitable alternates then the product is considered proprietary and still subject to 23 CFR 635.411 (c).

4. What is an example of a patented or proprietary item meeting the requirements of having 2 or more equally suitable alternates?

For examples of patented or proprietary items meeting the requirements of having 2 or more equally suitable alternates, review the NJDOT's Qualified Products List. In particular, for "reflective sheeting" there are several products under the material category of Reflective Sheeting, Type III that satisfy the 2 or more equally suitable alternates condition.

5. If a patented or proprietary item meets the requirements of having 2 or more equally suitable alternates, is a public interest finding still required?

No as long as the plan, specification, or qualified products list identifies all 3 products (i.e. patented or proprietary item and the 2 equally suitable alternates), a public interest finding is not required.

6. What is the difference between a sole source waiver and public interest finding?

Federal Highway Administration, New Jersey Division utilizes the terms interchangeably. Therefore if the State DOT is requesting to use a single or sole source with federal dollars then a public interest finding request is still needed. The "**Request for Approval of Patented or Proprietary Items on Federally Funded Projects**" form satisfies Division requests for a sole source waiver and public interest finding.

7. What should the State DOT consider during the material selection process?

If there are a limited number of products available that may meet the proposed specifications, a State DOT should undertake an engineering and economic analysis. The analysis should address the following questions:

- Are there other products on the market that meet the specifications?
- Are these products of satisfactory quality? and,
- Are the anticipated costs for the products are approximately the same?

The extent of the analysis should be appropriate for the value and complexity of the products involved, using life cycle cost analysis to develop cost comparisons based on comparable designs to meet product requirements using the anticipated service life for each product.

8. May contracting agencies set "above average" performance standards for a product?

Yes. A contracting agency may specify a higher or "above average" standard of performance on certain construction projects. However, if this "above average" standard reduces the pool of suitable products to a single proprietary product, the contracting agency must then prepare a public interest finding, which would document its minimum needs and support its contention that such a performance standard is necessary and reasonable to achieve these needs.

9. What factors should be considered when basing the use of a proprietary product on synchronization?

Synchronization may be based on function (the proprietary product is necessary for the satisfactory operation of the existing facility), aesthetics (the proprietary product is necessary to match the visual appearance of existing facilities), logistics (the proprietary product is interchangeable with products in with an agency's maintenance inventory) or a combination of the three. This may be best demonstrated by the following examples:

- A Federal aid construction project in City A includes the replacement of traffic signals and controllers in the downtown area. The City's existing signal control system is compatible with only Controller X. As part of its Downtown Beautification Plan, the City has specified Signal Pole Y for all intersections in the downtown area. To ensure FHWA participation, the contracting agency should provide sufficient documentation to support both functional and aesthetic synchronization, which could merely consist of a statement from the City justifying its decision to specify Controller X (functional synchronization with control system) and Signal Pole Y (aesthetic synchronization with signal poles).
- A Federal-aid construction project includes the replacement of existing substandard guardrail end terminals with those conforming to NCHRP 350 requirements. Upon project completion, the County will be responsible for the maintenance of the project. End Terminal T, which is NCHRP 350-compatible, has been constructed on other County-maintained routes in the vicinity. Due to scarce financial and labor resources, it desires to stock only one type of NCHRP 350-compatible end treatment, and has requested that the contracting agency to specify Terminal T. To ensure FHWA participation, the contracting agency should address these logistical issues in its supporting documentation.

10. What should be included in a State DOT request to use a patented or proprietary product for research or experimental purposes?

If the State requests to use a patented or proprietary product for research or for a distinctive type of construction on a relatively short section of road for experimental purposes, it must submit an experimental product work plan for review and approval. The work plan should provide for the evaluation of the proprietary product, and where appropriate, a comparison with current technology. Go to <http://www.fhwa.dot.gov/programadmin/contracts/expermnt.htm> for additional information.

11. What is a “sunset provision”?

A sunset provision is the length of time that the Division has granted approval to use the patented/proprietary product on statewide or multiple projects. The sunset provision date is the date upon which the Division approval will expire. Typically, public interest findings for specific projects will not have a sunset provision.

12. Can the Division office extend approval for the use of the patented or proprietary product past the “sunset provision” date?

No. Once the sunset provision date has expired, the State DOT must certify and/or request a new determination that the use of the patented or proprietary product is still in the interest of the public.

Questions and Answers Regarding Waivers

1. What is a proprietary product

Generally, this is a product, specification, or process identified in the plans or specifications as a "brand" or trade name (e.g. 3M, Corten). However, it may also be a product so narrowly specified that only a single provider can meet the specification.

2. Are patented products considered proprietary?

Yes, if the patented product is identified within the Plans or specifications as a "brand" or trade name; or the specification is written so that only the patented product can meet the specification.

3. If the patent of a product expires, does the Designer still need to certify and/or request to utilize the product for the product to be considered for use?

Depends upon the situation. If the patent expires but the product's name is identified within the Plans and specifications without 2 or more equally suitable alternates then the product is considered proprietary.

4. What is an example of a patented or proprietary item meeting the requirements of having 2 or more equally suitable alternates?

For examples of patented or proprietary items meeting the requirements of having 2 or more equally suitable alternates, review the NJDOT's Qualified Products List. In particular, for "reflective sheeting" there are several products under the material category of Reflective Sheeting, Type III that satisfy the 2 or more equally suitable alternates condition.

5. If a patented or proprietary item meets the requirements of having 2 or more equally suitable alternates, is a waiver still required?

No as long as the Plans, specification, or qualified products list identifies all 3 products (i.e. patented or proprietary item and the 2 equally suitable alternates), a waiver is not required.

6. What should the Designer consider during the material selection process?

If there are a limited number of products available that may meet the proposed specifications, the Designer should undertake an engineering and economic analysis. The analysis should address the following questions:

- Are there other products on the market that meet the specifications?
- Are these products of satisfactory quality? and,
- Are the anticipated costs for the products are approximately the same?

The extent of the analysis should be appropriate for the value and complexity of the products involved, using life cycle cost analysis to develop cost comparisons based on comparable designs to meet product requirements using the anticipated service life for each product.

7. May a Designer set "above average" performance standards for a product?

Yes. A Designer may specify a higher or "above average" standard of performance on certain construction projects. However, if this "above average" standard reduces the pool of suitable products to a single proprietary product, the Designer must then

prepare a waiver, which would document its minimum needs and support its contention that such a performance standard is necessary and reasonable to achieve these needs.

8. What factors should be considered when basing the use of a proprietary product on synchronization?

Synchronization may be based on function (the proprietary product is necessary for the satisfactory operation of the existing facility), aesthetics (the proprietary product is necessary to match the visual appearance of existing facilities), logistics (the proprietary product is interchangeable with products in with an agency's maintenance inventory) or a combination of the three.

9. What should be included in a Designer request to use a patented or proprietary product for research or experimental purposes?

If the Designer requests to use a patented or proprietary product for research or for a distinctive type of construction on a relatively short section of road for experimental purposes, it must submit an experimental product work plan for review and approval. The work plan should provide for the evaluation of the proprietary product, and where appropriate, a comparison with current technology.

Section 10 - Drainage

10.1 General Information

10.1.1 Introduction

Investigation of the impacts of surface water on the highway roadway, channels, and surrounding land is an integral part of every highway design. The end product of this investigation is a design, included in the plans, that provides an economical means of accommodating surface water to minimize adverse impacts in accordance with the design procedures.

Traffic safety is intimately related to surface drainage. Rapid removal of stormwater from the pavement minimizes the conditions which can result in the hazardous phenomenon of hydroplaning. Adequate cross-slope and longitudinal grade enhance such rapid removal. Where curb and gutter are necessary, the provision of sufficient inlets in conjunction with satisfactory cross-slope and longitudinal slope are necessary to efficiently remove the water and limit the spread of water on the pavement. Inlets at strategic points on ramp intersections and approaches to superelevated curves will reduce the likelihood of gutter flows spilling across roadways. Satisfactory cross-drainage facilities will limit the buildup of ponding against the upstream side of roadway embankments and avoid overtopping of the roadway.

Stormwater management is an increasingly important consideration in the design of roadway drainage systems. Existing downstream conveyance constraints, particularly in cases where the roadway drainage system connects to existing pipe systems, may warrant installation of detention/recharge basins to limit the peak discharge to the capacity of the downstream system. Specific stormwater management requirements to control the rate and volume of runoff may be dictated by various regulatory agencies.

Water quality is also an increasingly important consideration in the design of roadway drainage systems, particularly as control of non-point source pollution is implemented. Specific water quality requirements may be dictated by various regulatory agencies.

Detailed requirements regarding water quality control are included in Subsection 10.12 of this Manual and the separate document prepared by the New Jersey Department of Environmental Protection (NJDEP) entitled *New Jersey Stormwater Best Management Practices Manual*.

The optimum roadway drainage design should achieve a balance among public safety, the capital costs, operation and maintenance costs, public convenience, environmental enhancement and other design objectives.

The purpose of this manual is to provide the technical information and procedures required for the design of culverts, storm drains, channels, and stormwater management facilities. This section contains design criteria and information that will be required for the design of highway drainage structures. The complexity of the subject requires referring to additional design manuals and reports for more detailed information on several subjects.

10.1.2 Definitions and Abbreviations

Following is a list of important terms which will be used throughout this volume.

AWS - Allowable water surface elevations - The water surface elevation above which damage will occur.

AHW - Allowable headwater elevation - The allowable water surface elevation upstream from a culvert.

Backwater - The increased depth of water upstream from a dam, culvert, or other drainage structure due to the existence of such obstruction.

Best Management Practice (BMP) - A structural feature or non-structural development strategy designed to minimize or mitigate for impacts associated with stormwater runoff, including flooding, water pollution, erosion and sedimentation, and reduction in groundwater recharge.

Bioretention - A water quality treatment system consisting of a soil bed planted with native vegetation located above an underdrained sand layer. It can be configured as either a bioretention basin or a bioretention swale. Stormwater runoff entering the bioretention system is filtered first through the vegetation and then the sand/soil mixture before being conveyed downstream by the underdrain system.

Category One Waters - Those waters designated in the tables in N.J.A.C. 7:9B-1.15(c) through (i) for the purposes of implementing the Antidegradation Policies in N.J.A.C. 7:9B-1.5(d). These waters received special protection under the Surface Water Quality Standards because of their clarity, color, scenic setting or other characteristics of aesthetic value, exceptional ecological significance, exceptional recreational significance, exceptional water supply significance or exceptional fisheries resource(s). More information on Category One Waters can be found on the New Jersey Department of Environmental Protection's (NJDEP) web sites <http://www.state.nj.us/dep/> and <http://www.state.nj.us/dep/antisprawl/c1.html>.

Channel - A perceptible natural or artificial waterway which periodically or continuously contains moving water. It has a definite bed and banks which confine the water. A roadside ditch, therefore, would be considered a channel.

Culvert - A hydraulic structure that is typically used to convey surface waters through embankments. A culvert is typically designed to take advantage of submergence at the inlet to increase hydraulic capacity. It is a structure, as distinguished from a bridge, which is usually covered with embankment and is composed of structural material around the entire perimeter, although some are supported on spread footings with the stream bed serving as the bottom of the culvert. Culverts are further differentiated from bridges as having spans typically less than 20 feet.

Dam - Any artificial dike, levy or other barrier together with appurtenant works, which impounds water on a permanent or temporary basis, that raises the water level 5 feet or more above its usual mean low water height when measured from the downstream toe-of-dam to the emergency spillway crest or, in the absence of an emergency spillway, to the top of dam.

Design Flow - The flow rate at a selected recurrence interval.

Flood Hazard Area (Stream Encroachment) - Any manmade alteration, construction, development, or other activity within a floodplain. (The name "NJDEP Stream Encroachment Permit" is changed to the "NJDEP Flood Hazard Area Permit".)

Floodplain - The area described by the perimeter of the Design Flood. That portion of a river valley which has been covered with water when the river overflowed its banks at flood stage. An area designated by a governmental agency as a floodplain.

Fluvial Flood - A flood which is caused entirely by runoff from rainfall in the upstream drainage area and is not influenced by the tide or tidal surge.

Pipe - A conduit that conveys stormwater which is intercepted by the inlets, to an outfall where the stormwater is discharged to the receiving waters. The drainage system consists of differing lengths and sizes of pipe connected by drainage structures.

Recurrence Interval - The average interval between floods of a given magnitude.

Regulatory Flood - For delineated streams (i.e., those for which a State Adopted Flood Study exists), it is the Flood Hazard Area Design Flood, which is the 100-year peak discharge increased by 25 percent. State Adopted Flood Studies can be obtained from the NJDEP Bureau of Floodplain Management. For non-delineated streams, it is the 100-year peak discharge, based on fully developed conditions within the watershed.

Scour - Erosion of stream bed or bank material due to flowing water; often considered as being localized.

Time of Concentration (T_c) - Time required for water to flow from the most hydraulically distant (but hydraulically significant) point of a watershed, to the outlet.

Total Suspended Solids (TSS) - Solids in water that can be trapped by a filter, which include a wide variety of material, such as silt, decaying plant and animal matter, industrial wastes, and sewage.

10.1.3 Design Procedure Overview

This subsection outlines the general process of design for roadway drainage systems. Detailed information regarding drainage design is included in the remainder of this Manual.

- A. **Preliminary Investigation:** Will be performed using available record data, including reports, studies, plans, topographic maps, etc., supplemented with field reconnaissance. Information should be obtained for the project area and for adjacent stormwater management projects that may affect the highway drainage.
- B. **Site Analysis:** At each site where a drainage structure(s) will be constructed, the following items should be evaluated as appropriate from information given by the preliminary investigation:
 1. Drainage Area.
 2. Land Use.
 3. Allowable Headwater.
 4. Effects of Adjacent Structures (upstream and downstream).
 5. Existing Streams and Discharge Points.

6. Stream Slope and Alignment.
7. Stream Capacity.
8. Soil Erodibility.
9. Environmental permit concerns and constraints.

Coordination with representatives of the various environmental disciplines is encouraged.

- C. **Recurrence Interval:** Select a recurrence interval in accordance with the design policy set forth in Subsection 10.2.
- D. **Hydrologic Analysis:** Compute the design flow utilizing the appropriate hydrologic method outlined in Subsection 10.3.
- E. **Hydraulic Analysis:** Select a drainage system to accommodate the design flow utilizing the procedures outlined in the following parts:
 1. Channel Design – Subsection 10.4
 2. Drainage of Highway Pavements – Subsection 10.5
 3. Storm Drains - Subsection 10.6
 4. Median Drainage – Subsection 10.7
 5. Culverts - Subsection 10.8
- F. **Environmental Considerations:** Environmental impact of the proposed drainage system and appropriate methods to avoid or mitigate adverse impacts should be evaluated. Items to be considered include:
 1. Stormwater Management (including Quality, Quantity and Ground Water Recharge)
 2. Soil Erosion and Sediment Control
 3. Special Stormwater Collection Procedures
 4. Special Stormwater Disposal Procedures

These elements should be considered during the design process and incorporated into the design as it progresses.
- G. **Drainage Review:** The design engineer should inspect the drainage system sites to check topography and the validity of the design. Items to check include:
 1. Drainage Area
 - a. Size
 - b. Land Use
 - c. Improvements
 2. Effects of Allowable Computed Headwater
 3. Performance of Existing or Adjacent Structures
 - a. Erosion
 - b. Evidence of High Water
 4. Channel Condition
 - a. Erosion
 - b. Vegetation

- c. Alignment of Proposed Facilities with Channel
- 5. Impacts on Environmentally Sensitive Areas

10.2 Drainage Policy

10.2.1 Introduction

This part contains procedures and criteria that are essential for roadway drainage design.

10.2.2 Stormwater Management and Non-Point Source Pollution Control

Stormwater is a component of the total water resources of an area and should not be casually discarded but rather, where feasible, should be used to replenish that resource. In many instances, stormwater problems signal either misuse of a resource or unwise land activity.

Poor management of stormwater increases total flow, flow rate, flow velocity and depth of water in downstream channels. In addition to stormwater peak discharge and volume impacts, roadway construction or modification usually increases non-point source pollution primarily due to the increased impervious area. Properly designed stormwater management facilities, particularly detention/recharge basins, can also be used to mitigate non-point source pollution impacts by providing extended containment duration, thereby allowing settlement of suspended solids. Subsections 10.2.6, 10.11 and 10.12 of this Manual and the Stormwater Best Management Practices Manual prepared by the New Jersey Department of Environmental Protection (NJDEP) provide the guidance in the planning and design of these facilities. Web links to this NJDEP manual and additional guidance regarding stormwater, including regulatory compliance and permitting, may be found at <http://www.njstormwater.org>.

An assessment of the impacts the project will have on existing peak flows and watercourses shall be made by the design engineer during the initial phase. The assessment shall identify the need for stormwater management and non-point source pollution control (SWM & NPSPC) facilities and potential locations for these facilities. Mitigating measures can include, but are not limited to, detention/recharge basins, grassed swales, channel stabilization measures, and easements.

Stormwater management, whether structural or non-structural, on or off site, must fit into the natural environment, and be functional, safe, and aesthetically acceptable. Several alternatives to manage stormwater and provide water quality may be possible for any location. Careful design and planning by the engineer, hydrologist, biologist, environmentalist, and landscape architect can produce optimum results.

Design of SWM & NPSPC measures must consider both the natural and man-made existing surroundings. The design engineer should be guided by this and include measures in design plans that are compatible with the site specific surroundings. Revegetation with native, non-invasive grasses, shrubs and possibly trees may be required to achieve compatibility with the surrounding environment. Design of major SWM & NPSPC facilities may require coordination with the NJDOT Bureau of Landscape Architecture and Environmental Solutions, and other state and various regulatory agencies.

SWM & NPSPC facilities shall be designed in accordance with Subsections 10.11 and 10.12 and the *Stormwater Best Management Practices Manual* prepared by the NJDEP or other criteria where applicable, as directed by the Department.

Disposal of roadway runoff to available waterways that either cross the roadway or

are adjacent to it spaced at large distances, requires installation of long conveyance systems. Vertical design constraints may make it impossible to drain a pipe or swale system to existing waterways. Discharging the runoff to the groundwater with a series of leaching or seepage basins (sometimes called a Dry Well) may be an appropriate alternative if groundwater levels and non-contaminated, permeable soil conditions allow a properly designed system to function as designed. The decision to select a seepage facility design must consider geotechnical, maintenance, and possibly right-of-way (ROW) impacts and will only be allowed if no alternative exists.

The seepage facilities must be designed to store the entire runoff volume for a design storm compatible with the storm frequency used for design of the roadway drainage facilities or as directed by the Department. As a minimum, the seepage facilities shall be designed to store the increase in runoff volume from new impervious surfaces as long as adequate overflow conveyance paths are available to safely carry the larger flows to a stable discharge point.

Installation of seepage facilities can also satisfy runoff volume control and water quality concerns which may be required by an environmental permit.

Additional design guidelines are included in the NJDEP *Stormwater Best Management Practices Manual*.

Hydrology and Hydraulics Checklist for Access or Operations Permits (Developers)

Developers/designers who are proposing the development of properties adjacent to State roads/ROW that requires connection of their drainage system or that may hydraulically impact NJDOT drainage systems or roadways must comply with the NJDOT drainage standards. The developer/designer must also submit and address all items in this Hydrology and Hydraulics Checklist in order to obtain approval from NJDOT Hydrology and Hydraulics Unit necessary for Access or Drainage Permits.

	Hydrology and Hydraulics Checklist for Permits	YES	NO	N/A
1	<p>The following items are required with each submission:</p> <ul style="list-style-type: none"> • Hydrology and Hydraulics Checklist and Supporting information • Stormwater Management (SWM) Report including the following: <ul style="list-style-type: none"> ○ Project description including total area of disturbance and net increase in impervious area ○ Summary tables demonstrating compliance with quality, quantity and groundwater recharge criteria ○ All supporting data and detailed calculations ○ Soil profile pit testing results ○ Pipe and inlet analysis • Plan Sheets: <ul style="list-style-type: none"> ○ Existing and Proposed Drainage, Grading and Utility Plans ○ Existing and Proposed Grading Plan at the entrance of the access point to the State Highway including grades of the gutter line ± 100 feet from the center of the access point. ○ Profile of the Driveway (Access Point) and ± 100 feet from the center of the access point. ○ Construction Details • Maintenance Plan and Schedule for all Best Management Practices (BMPs) 			
2	<p>For new drainage which ties into existing roadway systems, demonstrate that the existing drainage system has adequate capacity and is free of any siltation or blockages. Reconstructed inlets or manholes, along with all of their associated pipes, must be cleaned (to the outfall). Whenever possible, eliminate proposed manholes or inlets within the traveled way of the road.</p>			
3	<p>Water has not been trapped on or diverted to another private property or another watershed.</p>			

4	The project triggers NJDEP Stormwater Management (SWM) Regulations (Major Development: One acre or more of disturbance or ¼ acre or more of new impervious)			
4A	Quantity (Major Development) in accordance with N.J.A.C. 7:8-5.4.			
4B	Quality (only if net increase of impervious by 1/4 acre or more) in accordance with N.J.A.C. 7:8-5.5.			
4C	Groundwater Recharge (Major Development) in accordance with N.J.A.C. 7:8-5.6.			
4D	Discharges within a 300-foot riparian zone provide 95% TSS reduction in accordance with N.J.A.C. 7:8 and 7:13.			
5	Quantity: No increase in the peak flow rates in the post-developed conditions is permitted to the NJDOT Drainage System. Quantity impacts are addressed at each discharge to the NJDOT drainage system. Calculations are shown for the 2, 10, 25, and 100-year storms. Please refer to Table 10-2 of the <i>NJDOT Roadway Design Manual</i> to determine if additional storm events need to be analyzed.			
6	Quantity: No increase in flows to the NJDOT gutter or other portions of the drainage system are allowed for the 2, 10, 25, and 100-year storms including increases resulting from curbing areas of existing umbrella drainage.			
7	Quantity: No increase in flooding to the NJDOT drainage system or roadway is permitted from adjacent drainage or streams for the 2, 10, 25, and 100 year storms. Please refer to Table 10-2 of the <i>NJDOT Roadway Design Manual</i> to determine if additional storm events need to be analyzed.			
8	Quality: Even if there is no increase in impervious cover: <ul style="list-style-type: none"> - If a project proposes storage or transport of petroleum products on areas which drain to any NJDOT drainage system, water quality mitigation will be required. - If the applicant proposes to change existing drainage patterns which may increase pollutant loads to the NJDOT drainage system, water quality treatment must be implemented. 			
9	The NRCS method is utilized for stormwater management calculations OR where the rational method is used, the modified rational method is utilized to establish runoff volume for the critical duration as described in Appendix A9 of the <i>Soil Erosion and Sediment Control Standards in New Jersey</i> .			
10	All proposed basins utilizing infiltration meet the criteria of the groundwater mounding analysis as required by N.J.A.C. 7:8-5.4(a)2.iv. Infiltration basin drain down times utilize the reduced infiltration rate due to mounding to demonstrate that infiltration BMPs drain within 72 hours.			
11	Even if the project is not a major development, all BMPs are designed in accordance with the <i>NJ Stormwater Best Management Practices (BMP) Manual</i> .			
12	Drainage area maps are provided: <ul style="list-style-type: none"> - Inlet Drainage Area Maps - Existing and proposed sub-drainage area maps with Tc flow paths. 			
13	All soil evaluation for establishing permeability rates, Seasonal High Water Table (SHWT), and Hydrologic Soil Groups is done in accordance with Appendix E of the <i>NJ Stormwater BMP Manual</i> . Soil logs provide ground elevations and all relevant elevations.			
14	The SHWT elevations, locations for the soil borings and profile pits, as well as locations of all stormwater management BMPs are shown on the plan sheets.			
15	The SHWT is at least 1 foot below any proposed detention basin and 2 feet below the bottom of any proposed infiltration BMP (infiltration			

	basin, bio-retention with infiltration, underground infiltration structures, etc.)			
16	Outfall protection has been specified and shown on the construction plans where needed (length, width, and D50 stone size) with appropriate details.			
17	Drainage pipe sizes and inverts are shown on the plans (existing and proposed). This includes existing drainage infrastructure downstream of the site.			
18	Outlet Control Structure: Pipes that discharge directly into the NJDOT drainage system must have an associated outlet control structure, whether or not the discharge is from a stormwater management basin			
19	Inlet Details for Type B and C Inlets are incorporated into the plan.			
20	Rights-of-way (ROW) are clearly shown on the plans.			
21	The maintenance schedule and plan are written according to Chapter 8, the chapter pertaining to the applicable BMP of the NJ Stormwater BMP Manual, as well as N.J.A.C. 7:8-5.8.			
22	Basins or other stormwater management measures are placed on the developer's property or ROW with an agreement for the developer or owner to maintain with details in the maintenance plan.			
23	The approved maintenance schedule and plan will be recorded as a part of the property's deed.			
24	Evidence of all applicable permit submissions or prior approvals provided to the NJDOT. Criteria from all relevant permitting agencies including, but not limited to Pinelands Commission, NJDEP, etc., have been applied in the design including any associated permit conditions.			
25	Two sets of calculations (stormwater management, drainage, and flood analysis, as necessary) and two sets of signed and sealed plans are included with the submission. Copies of executable H&H models are provided.			
26	Upon successfully addressing all hydrologic and hydraulic comments, the applicant/designer will submit a final electronic signed and sealed copy of all plan sheets, the drainage report, and any other relevant supporting materials to the NJDOT Hydrology and Hydraulics Unit before the approval of any access, operation or drainage permit.			

No portion of the project which may result in impacts to the NJDOT roadway or drainage system should be constructed prior to approval from NJDOT.

The applicant/designer acknowledges that any construction is at their own risk and that the construction of portions of the project prior to the issuance of any approval does not obligate the NJDOT to approve the constructed project.

Designer provides "yes", "no", or "not applicable" response for each checklist item.

"N/A or not applicable" response – indicates checklist item does not apply to the project.

"No" response – indicates the checklist item was not provided as required – an explanatory comment is required.

Should the applicant/designer encounter any site conditions or additional information which would render inaccurate any portion of the hydrologic and hydraulic analysis submitted, the applicant agrees to immediately contact the NJDOT office issuing the permit in order to determine whether design changes are warranted prior to continuing construction. (Examples of site conditions which may significantly impact the submitted information include, but are not limited to, SHWT at higher elevations than anticipated, encountering a restrictive layer, and permeability rates inconsistent with design permeability rates, etc.)

Engineer Signature

NJPE License Number

Date

10.2.3 Allowable Water Surface Elevation

Determine the allowable water surface elevation (AWS) at every site where a drainage facility will be constructed. The proposed drainage structure should cause a ponding level, hydraulic grade line elevation, or backwater elevation no greater than the AWS when the design flow is imposed on the facility. The AWS must comply with NJDEP requirements for locations that require a NJDEP Flood Hazard Area Permit. The AWS upstream of a proposed drainage facility at locations that do not require a NJDEP Flood Hazard Area Permit should not cause additional flooding outside the NJDOT property or acquired easements. An AWS that exceeds a reasonable limit may require concurrence of the affected property owner.

A floodplain study prepared by the New Jersey Department of Environmental Protection, the Federal Emergency Management Agency, the U.S. Army Corps of Engineers, or other recognized agencies will be available at some sites. The elevations provided in the approved study will be used in the hydraulic model.

The Table 10-1 presents additional guidelines for determining the AWS at locations where a NJDEP Flood Hazard Area Permit is not required.

Table 10-1
Allowable Water Surface (AWS)

Land Use or Facility	AWS
Residence	Floor elevation (slab floor), basement window, basement drain (if seepage potential is present)
Commercial Building (barn, store, warehouse, office building, etc.)	Same as for residence
Bridge	Low steel
Culvert	Top of culvert - New structure Outside edge of road - Existing structure
Levee	Min 1 foot below top of Levee
Dam	See NJDEP Dam Safety Standards
Channel	Min 1 foot below top of low bank
Road	Min 1 foot below top of grate or manhole rim for storm sewers

The peak 100-year water surface elevation for any new detention/retention facility must be contained within NJDOT property or acquired easements. No additional flooding shall result outside the NJDOT property or acquired easements.

10.2.4 Recurrence Interval

Select a flood recurrence interval consistent with Table 10-2:

**Table 10-2
Recurrence Interval**

Recurrence Interval	Facility Description
100-Year	Any drainage facility that requires a NJDEP permit for a non-delineated stream. For delineated watercourses contact the NJDEP Bureau of Floodplain Management.
50-Year	Any drainage structure that passes water under a freeway or interstate highway embankment, with a headwall or open end at each side of the roadway.
25-Year	Any drainage structure that passes water under a land service highway embankment, with a headwall or open end at each side of the roadway. Also, pipes along the mainline of a freeway or interstate highway that convey runoff from a roadway low point to the disposal point, a waterway, or a stormwater maintenance facility.
15-Year	Longitudinal systems and cross drain pipes of a freeway or interstate highway. Also pipes along mainline of a land service highway that convey runoff from a roadway low point to the disposal point, a waterway, or a stormwater maintenance facility.
10-Year	Longitudinal systems and cross drain pipes of a land service highway.

10.2.5 Increasing Fill Height Over Existing Structures

Investigate the structural adequacy of existing structures that will have additional loading as the result of a surcharge placement or construction loads.

10.2.6 Regulatory Compliance

Proposed construction must comply with the requirements of various regulatory agencies. Depending on the project location, these agencies could include, but are not limited to, the US Army Corps of Engineers, U. S. Coast Guard, the New Jersey Department of Environmental Protection, the Pinelands Commission, the Highlands Council and the Delaware and Raritan Canal Commission.

The NJDEP has adopted amendments to the New Jersey Pollutant Discharge Elimination System (NJPDES) program to include a Construction Activity Stormwater General Permit (NJG 0088323). This program is administered by the NJDEP and in coordination with the NJ Department of Agriculture through the Soil Conservation Districts (SCD). Certification by the local SCD is not required for NJDOT projects. However, certification by the local SCD is required for non-NJDOT projects (e.g., a County is the applicant). A Request for Authorization (RFA) for a NJPDES Construction Stormwater General Permit is needed for projects that disturb one (1) acre or more.

The RFA must be submitted to the NJDEP. For non-NJDOT projects, the SCD certification must be obtained prior to submission of the RFA.

The NJDEP has adopted the New Jersey Stormwater Management Rule, N.J.A.C. 7.8. The Stormwater Management Rule governs all projects that provide for ultimately disturbing one (1) or more acres of land or increasing impervious surface by 0.25 acre or more. The following design and performance standards need to be addressed for any project governed by the Stormwater Management Rule:

- Nonstructural Stormwater Management Strategies, N.J.A.C. 7:8-5.3
To the maximum extent possible, nonstructural stormwater BMPs shall be used to meet the requirements of the New Jersey Stormwater Management Rule. If the design engineer determines that it is not feasible for engineering, environmental or safety reason to utilize nonstructural stormwater BMPs, structural BMPs may be utilized.
- Groundwater Recharge, N.J.A.C. 7:8-5.4(a)2
For the project, the design engineer shall demonstrate either that the stormwater BMPs maintain 100% of the average annual preconstruction groundwater recharge volume for the site; or that the increase in stormwater runoff volume from pre-construction to post-construction for the 2-year storm is infiltrated. NJDEP has provided an Excel Spreadsheet to determine the project sites annual groundwater recharge amounts in both pre- and post-development site conditions. A full explanation of the spreadsheet and its use can be found in Chapter 6 of the New Jersey Stormwater Best Management Practices Manual. A copy of the spreadsheet can be downloaded from <http://www.njstormwater.org>.
- Stormwater Quantity, N.J.A.C. 7:8-5.4(a)3
Stormwater BMPs shall be designed to do one of the following:
 1. The post-construction hydrograph for the 2-year, 10-year, and 100-year storm events do not exceed, at any point in time, the pre-construction runoff hydrographs for the same storm events.
 2. There shall be no increase, as compared to the pre-construction condition, in peak runoff rates of stormwater leaving the project site for the 2-year, 10-year, and 100-year storm events and that the increased volume or change in timing of stormwater runoff will not increase flood damage at or downstream of the site. This analysis shall include the analysis of impacts of exiting land uses and projected land uses assuming full development under existing zoning and land use ordinances in the drainage area.
 3. The post-construction peak runoff rates for the 2-year, 10-year, and 100-year storm events are 50%, 75%, and 80%, respectively, of the pre-construction rates. The percentages apply only to the post-construction stormwater runoff that is attributed to the portion of the site on which the proposed development or project is to be constructed.
 4. Along tidal or tidally influenced waterbodies and/or in tidal floodplains, stormwater runoff quantity analysis shall only be applied if the increased volume of stormwater runoff could increase flood damages below the point of discharge. Tidal flooding is the result of higher than normal tides which in turn inundate low lying coastal areas. Tidal areas are not only activities in tidal waters, but also the area adjacent to the water, including fluvial rivers and

streams, extending from the mean high water line to the first paved public road, railroad or surveyable property line. At a minimum, the zone extends at least 100 feet but no more than 500 feet inland from the tidal water body.

- Stormwater Quality, N.J.A.C. 7:8-5.5

Stormwater BMPs shall be designed to reduce the post-construction load of TSS in stormwater runoff generated from the water quality storm by 80% of the anticipated load from the developed site. Subsection 10.12 and the Stormwater Best Management Practices Manual provide guidance in the planning and design of these facilities.

- Stormwater Maintenance Plan, N.J.A.C. 7:8-5.8

The design engineer shall prepare a stormwater management facility maintenance plan in accordance with the New Jersey Stormwater Management Rule. At a minimum the maintenance plan shall include specific preventative maintenance tasks and schedules. Maintenance guidelines for stormwater management measures are available in the New Jersey Stormwater Best Management Practices Manual.

For projects located within the Pinelands or Highlands areas of the State, the design engineer should consult with the NJDEP to determine what additional stormwater management requirements may apply to the project. Additional information about the Pinelands can be found at <http://www.state.nj.us/pinelands/>, and information about the Highlands can be found at <http://www.nj.gov/dep/highlands/>.

As previously mentioned for NJDOT projects, a RFA for a NJPDES Construction Activity Stormwater General Permit does not have to be sent to the SCD, but instead the Bureau of Landscape Architecture and Environmental Solutions sends a notification directly to the NJDEP. A RFA would have to be sent to the appropriate Soil Conservation District only for non-NJDOT projects (i.e. a County is the applicant).

The NJDOT Bureau of Landscape Architecture and Environmental Solutions will provide guidance regarding project specific permit requirements. Guidance regarding NJDEP Flood Hazard Area Permits is provided in Subpart 10.2.7.

10.2.7 Flood Hazard Area (Stream Encroachment)

NJDEP Flood Hazard Area Permits for which the NJDOT is the applicant shall be processed in accordance with the [Capital Project Delivery](http://www.state.nj.us/transportation/capital/pd/), (<http://www.state.nj.us/transportation/capital/pd/>), website and the following guidelines.

Applicability and specific requirements for all NJDEP Flood Hazard Area Permit may be found in the most recent Flood Hazard Area Control Act Rules as adopted by the New Jersey Department of Environmental Protection (NJDEP). Specific requirements for bridges and culverts are contained in N.J.A.C. 7.13-11.7.

In cases where the regulatory flood causes the water surface to overflow the roadway, the design engineer shall, by raising the profile of the roadway, by increasing the size of the opening or a combination of both, limit the water surface to an elevation equal to the elevation of the outside edge of shoulder. The design engineer is cautioned, however, to critically assess the potential hydrologic and hydraulic effects upstream and downstream of the project, which may result from impeding flow by raising the roadway profile, or from decreasing upstream storage and allowing additional flow downstream by increasing existing culvert openings. The design engineer shall determine what effect the resulting reduction of storage will have on peak flows and the downstream properties in accordance with the Flood Hazard Area Control Act

Rules. Stormwater management facilities may be required to satisfy these requirements.

N.J.A.C. 7:13-3.2 establishes the selection of a method to determine the flood hazard area and floodway along a regulated water. Hydraulic evaluation of existing roadway stream crossings may reveal that the water surface elevation for this discharge overtops the roadway. Compliance with both the bridge and culvert requirements presented in N.J.A.C. 7:13-11.7 and the NJDOT requirement to avoid roadway overtopping may require coordination between the agencies involved to achieve a reasonable design approach. In addition to the regulations listed above, the bridge and culvert design will be in compliance with the NJDEP's Technical Manual for Land Use Regulation Program, Bureaus of Inland and Coastal Regulations, NJDEP Flood Hazard Area Permit, which includes the following:

- Structures will pass the regulatory flood without increasing the upstream elevation of the flood profile by more than 0.2 feet if the structure is new or the upstream and downstream flood profile by more than 0.0 feet if the structure is a replacement for an existing structure.
- For new structures that result in lowering the downstream water surface elevation by 2 or 3 feet, the engineer must perform a routing analysis to verify that there are no adverse impacts further downstream.

Activities located along tidal waterbodies listed in the NJDEP Flood Hazard Area Control Act Rules may also be governed by other NJDEP regulations.

When a permit is required, the NJDOT Drainage Engineer shall be notified in writing. This notice shall include a USGS Location Map with the following information:

- A title block identifying the project by name, the applicant, and the name of the quadrangle.
- The limits of the project and point of encroachment shown in contrasting colors on the map.
- The upstream drainage area contributing runoff shall be outlined for all streams and/or swales within or along the project.
- If the NJDOT Project Engineer, after consultation with NJDEP, determines that a pre-application meeting is desirable, the following engineering data may also be required for discussion at a NJDEP pre-application meeting.
- A 1" = 30' scale plan with the encroachment location noted thereon.
- In the case of a new or replacement structure or other type encroachment, the regulatory floodwater surface elevation as required for the review and analysis of the project impacts and permit requirements.

The design engineer is also required to determine whether a particular watercourse involved in the project is classified by the State as a Category One waterbody, and if so, shall design the project in accordance with the provisions at N.J.A.C. 7:9B. Projects involving a Category One waterbody shall be designed such that a 300-foot special water resource protection area is provided on each side of the waterbody. Encroachment within this 300-foot buffer is prohibited except in instances where preexisting disturbance exists. Where preexisting disturbance exists, encroachment is allowed, provided that the 95% TSS removal standard is met and the loss of function is addressed. More information on Category One Waters can be found at [NJDEP's web sites http://www.state.nj.us/dep](http://www.state.nj.us/dep) or http://www.nj.gov/dep/landuse/fha/fha_rz.html.

N.J.A.C. 7:13-10.2 sets forth the requirements for a regulated activity in a riparian zone. The width of the riparian zone is set forth at N.J.A.C. 7:13-4.1. The riparian zones established are separate from and in addition to any other similar zones or buffers established to protect surface waters. Table 10-2A, Maximum Allowable Disturbance to Riparian Zone Vegetation, as taken from the Flood Hazard Area Control Act Rules N.J.A.C. 7:13, November 5, 2007 (FHACA), sets forth limits on the area of vegetation that can be disturbed for various regulated activities provided the requirements for each activity are satisfied as per N.J.A.C. 7.13-10.2.

Table 10-2a**Maximum Allowable Disturbance To Riparian Zone Vegetation**

Proposed Regulated Activity	Referenced Paragraph in FHACA Rules pg. 87	Maximum Area of Vegetation Disturbance Based on the Width of the Riparian Zone			
		50-foot Riparian Zone	150-foot Riparian Zone	300-foot Riparian Zone	
• Railroad or public roadway					
New	Crossing a water	(e)	5,000 ft ²	15,000 ft ²	30,000 ft ²
	Not crossing a water		2,000 ft ²	6,000 ft ²	12,000 ft ²
Reconstructed	Crossing a water	(f)	2,500 ft ²	7,500 ft ²	15,000 ft ²
	Not crossing a water		1,000 ft ²	3,000 ft ²	6,000 ft ²
• Private roadway that serves as a driveway to one private residence					
New	Crossing a water	(g)	1,500 ft ²	4,500 ft ²	9,000 ft ²
	Not crossing a water		600 ft ²	1,800 ft ²	3,600 ft ²
Reconstructed	Crossing a water	(h)	750 ft ²	2,250 ft ²	4,500 ft ²
	Not crossing a water		300 ft ²	900 ft ²	1,800 ft ²
• All other private roadways					
New	Crossing a water	(g)	3,000 ft ²	9,000 ft ²	18,000 ft ²
	Not crossing a water		1,200 ft ²	3,600 ft ²	7,200 ft ²
Reconstructed	Crossing a water	(h)	1,500 ft ²	4,500 ft ²	9,000 ft ²
	Not crossing a water		600 ft ²	1,800 ft ²	3,600 ft ²
• Bank stabilization or channel restoration					
Accomplished with vegetation alone		(i)	No limit if disturbance is justified		
Other permanent disturbance			2,000 ft ²	2,000 ft ²	2,000 ft ²
Other temporary disturbance			1,000 ft ²	3,000 ft ²	6,000 ft ²
• Stormwater discharge (including pipe and conduit outlet protection)					
Permanent disturbance		(j)	1,000 ft ²	1,000 ft ²	1,000 ft ²
Temporary disturbance			1,000 ft ²	3,000 ft ²	6,000 ft ²
• Utility line (temporary disturbance only)					
Crossing a water		(k)	2,000 ft ²	6,000 ft ²	12,000 ft ²
Not crossing a water		(l)	800 ft ²	2,400 ft ²	4,800 ft ²
• Other projects					
Private residence		(m)	2,500 ft ²	5,000 ft ²	5,000 ft ²
Addition, garage, barn or shed		(n)	1,000 ft ²	2,000 ft ²	2,000 ft ²
Flood control project		(o)	3,000 ft ²	9,000 ft ²	18,000 ft ²
Public accessway or public access area		(p)	No limit if disturbance is justified		
Water-dependent development		(q)	No limit if disturbance is justified		
All other regulated activities		(r)	1,000 ft ²	3,000 ft ²	6,000 ft ²

10.2.8 Soil Erosion and Sediment Control

The design for projects that disturb 5,000 or more square feet do not require plan certification from the local Soil Conservation District, but shall be prepared in accordance with the current version of the NJDOT Soil Erosion and Sediment Control Standards, including the required report. The Soil Erosion and Sediment Control Report shall include calculations and plans that address both temporary and permanent items for the engineering and vegetative standards. Calculations shall be shown for items that require specific sizing (e.g., rip rap, settling basins, etc.). Certification by the local Soil Conservation District is not required for NJDOT projects. NJDOT self-certifies the Soil Erosion and Sediment Control Plans for NJDOT projects. Certification by the local Soil Conservation District is required for non-NJDOT projects (i.e., a County is the applicant).

10.3 Hydrology

10.3.1 Introduction

Hydrology is generally defined as a science dealing with the interrelationship between water on and under the earth and in the atmosphere. For the purpose of this section, hydrology will deal with estimating flood magnitudes as the result of precipitation. In the design of highway drainage structures, floods are usually considered in terms of peak runoff or discharge in cubic feet per second (cfs) and hydrographs as discharge per time. For drainage facilities which are designed to control volume of runoff, like detention facilities, or where flood routing through culverts is used, then the entire discharge hydrograph will be of interest. The analysis of the peak rate of runoff, volume of runoff, and time distribution of flow is fundamental to the design of drainage facilities. Errors in the estimates will result in a structure that is either undersized and causes more drainage problems or oversized and costs more than necessary.

In the hydrologic analysis for a drainage facility, it must be recognized that many variable factors affect floods. Some of the factors which need to be recognized and considered on an individual site by site basis include:

- rainfall amount and storm distribution,
- drainage area size, shape and orientation, ground cover, type of soil,
- slopes of terrain and stream(s),
- antecedent moisture condition,
- storage potential (overbank, ponds, wetlands, reservoirs, channel, etc.),
- watershed development potential, and
- type of precipitation (rain, snow, hail, or combinations thereof), elevation.

The type and source of information available for hydrologic analysis will vary from site to site. It is the responsibility of the design engineer to determine the information required for a particular analysis. This subsection contains hydrologic methods by which peak flows and hydrographs may be determined for the hydraulic evaluation of drainage systems of culverts, channels and median drains.

10.3.2 Selection of Hydrologic Methods

The guidelines in Table 10-3 should be used to select the hydrology method for computing the design peak flow.

Table 10-3
Hydrologic Method

Size of Drainage Area	Hydrologic Method[‡]
Less than 20 Acres	Rational Formula or Modified Rational Method
Less than 5 Square Miles	NRCS* TR-55 Methodology
Greater than 1 Acre ^f	NRCS* TR-20, HEC-1 Method, HEC-HMS or others [†]

[‡] For all projects in certain areas south of the South Central flat inland and New Jersey Coastal Plain, the DELMARVA Unit Hydrograph shall be incorporated into the design procedure. Contact the local Soil Conservation District to determine if the DELMARVA unit hydrograph is to be used for the project.

* US Natural Resources Conservation Service (NRCS), formerly the US Soil Conservation Service (SCS).

^f These hydrologic models are not limited by the size of the drainage area. They are instead limited by uniform curve number, travel time, etc. Most of these limitations can be overcome by subdividing the drainage areas into smaller areas. See the appropriate user's manual for a complete list of limitations for each hydrologic model.

[†] Many hydrologic models exist beyond those that are listed here. If a model is not included, then the design engineer should ensure that the model is appropriate and that approvals are obtained from the Department.

The peak flow from a drainage basin is a function of the basin's physiographic properties such as size, shape, slope, soil type, land use, as well as climatological factors such as mean annual rainfall and selected rainfall intensities. The methods presented in the guideline should give acceptable predictions for the indicated ranges of drainage area sizes and basin characteristics.

Other hydrologic methods may be used only with the approval of the Department.

Note: If a watercourse has had a NJDEP adopted study prepared for the particular reach where the project is located, that study should be used for the runoff and water surface profiles. N.J.A.C. 7:13-3.1 provides the general provisions for determining the flood hazard area and floodway along regulated water. This provides six methods for determining the flood hazard area and floodway along a regulated water as follows.

Method 1 (Department delineation method) as described at N.J.A.C. 7:13-3.3;

Method 2 (FEMA tidal method) as described at N.J.A.C. 7:13-3.4(d);

Method 3 (FEMA fluvial method) as described at N.J.A.C. 7:13-3.4(e)

Method 4 (FEMA hydraulic method) as described at N.J.A.C. 7:13-3.4(f)

Method 5 (approximation method) as described at N.J.A.C. 7:13-3.5; and

Method 6 (calculation method) as described at N.J.A.C. 7:13-3.6

Computation of peak discharge must consider the condition that yields the largest rate. Proper hydrograph combination is essential. It may be necessary to evaluate several different hydrograph combinations to determine the peak discharge for basins containing hydrographs with significantly different times for the peak discharge. For example, the peak discharge for a basin with a large undeveloped area contributing toward the roadway may result from either the runoff at the time when the total area reaches the roadway or the runoff from the roadway area at its peak time plus the runoff from the portion of the overland area contributing at the same time.

10.3.3 Rational Formula

The rational formula is an empirical formula relating runoff to rainfall intensity. It is expressed in the following form:

$$Q = CIA$$

where:

- Q**= peak flow in cubic feet per second (ft³/s)
- C**= runoff coefficient (weighted)
- I**= rainfall intensity in inches (in) per hour
- A**= drainage area in acres

A. Basic Assumptions

1. The peak rate of runoff (Q) at any point is a direct function of the average rainfall intensity (I) for the Time of Concentration (T_c) to that point.
2. The recurrence interval of the peak discharge is the same as the recurrence interval of the average rainfall intensity.
3. The Time of Concentration is the time required for the runoff to become established and flow from the most distant point of the drainage area to the point of discharge.

A reason to limit use of the rational method to small watersheds pertains to the assumption that rainfall is constant throughout the entire watershed. Severe storms, say of a 100-year return period, generally cover a very small area. Applying the high intensity corresponding to a 100-year storm to the entire watershed could produce greatly exaggerated flows, as only a fraction of the area may be experiencing such intensity at any given time.

The variability of the runoff coefficient also favors the application of the rational method to small, developed watersheds. Although the coefficient is assumed to remain constant, it actually changes during a storm event. The greatest fluctuations take place on unpaved surfaces as in rural settings. In addition, runoff coefficient values are much more difficult to determine and may not be as accurate for surfaces that are not smooth, uniform and impervious.

To summarize, the rational method provides the most reliable results when applied to small, developed watersheds and particularly to roadway drainage design. The validity of each assumption should be verified for the site before proceeding.

B. Procedure

1. Obtain the following information for each site:
 - a. Drainage area
 - b. Land use (% of impermeable area such as pavement, sidewalks or roofs)
 - c. Soil types (highly permeable or impermeable soils)
 - d. Distance from the farthest point of the drainage area to the point of discharge
 - e. Difference in elevation from the farthest point of the drainage area to the point of discharge
2. Determine the Time of Concentration (T_c). See Subpart 10.3.5. (Minimum T_c is 10 minutes).
3. Determine the rainfall intensity rate (I) for the selected recurrence intervals.
4. Select the appropriate C value.
5. Compute the design flow ($Q = CIA$).

The runoff coefficient (C) accounts for the effects of infiltration, detention storage, evapo-transpiration, surface retention, flow routing and interception. The product of C and the average rainfall intensity (I) is the rainfall excess of runoff per acre.

The runoff coefficient should be weighted to reflect the different conditions that exist within a watershed.

Example:

$$C_w = \frac{A_1C_1 + A_2C_2 \dots A_NC_N}{A_1 + A_2 \dots A_N}$$

- C. Value for C : Select the appropriate value for C from Table 10-4:

Table 10-4
Recommended Coefficient of Runoff Values
for Various Selected Land Uses

Land Use	Description	Hydrologic Soils Group			
		A	B	C	D
Cultivated Land	without conservation treatment	0.49	0.67	0.81	0.88
	with conservation treatment	0.27	0.43	0.67	0.67
Pasture or Range Land Meadow	poor condition	0.38	0.63	0.78	0.84
	good condition	---	0.25	0.51	0.65
	good condition	---	---	0.41	0.61
Wood or Forest Land	thin stand, poor cover, no mulch	---	0.34	0.59	0.70
	good cover	---	---	0.45	0.59
Open Spaces, Lawns, Parks, Golf Courses, Cemeteries	Good Condition	---	0.25	0.51	0.65
	Fair Condition	---	0.45	0.63	0.74
Commercial and Business Area	85% impervious	0.84	0.90	0.93	0.96
Industrial Districts	72% impervious	0.67	0.81	0.88	0.92
Residential Average Lot Size (acres)	average % impervious				
1/8	65	0.59	0.76	0.86	0.90
1/4	38	0.29	0.55	0.70	0.80
1/3	30	---	0.49	0.67	0.78
1/2	25	---	0.45	0.65	0.76
1	20	---	0.41	0.63	0.74
Paved Areas	parking lots, roofs, driveways, etc.	0.99	0.99	0.99	0.99
Streets and Roads	paved with curbs & storm sewers	0.99	0.99	0.99	0.99
	gravel	0.57	0.76	0.84	0.88
	dirt	0.49	0.69	0.80	0.84

NOTE: Values are based on NRCS (formerly SCS) definitions and are average values.

Source: Technical Manual for Land Use Regulation Program, Bureau of Inland and Coastal Regulations, NJDEP Flood Hazard Area Permits, New Jersey Department of Environmental Protection

- D. Determination of Rainfall Intensity Rate (I): Determine the Time of Concentration (T_c) in minutes for the drainage basin. Refer to Subpart 10.3.5 for additional information.

Determine the value for rainfall intensity for the selected recurrence interval with a duration equal to the Time of Concentration from Figures 10-B through 10-D. Rainfall Intensity "I" curves are presented in Figures 10-B through 10-D. The curves provide for variation in rainfall intensity according to location, storm frequency, and Time of Concentration. Select the curve of a particular region

where the site in question is located (see Figure 10-A for determination of the particular region). For projects that fall on the line or span more than one boundary, the higher intensity should be used for the entire project. The Regions can be defined by the following:

North Region: All Counties north of the Mercer and Monmouth County lines.

South Region: All Counties South of the Hunterdon, Somerset, and Middlesex County lines except for those areas located in the East Region.

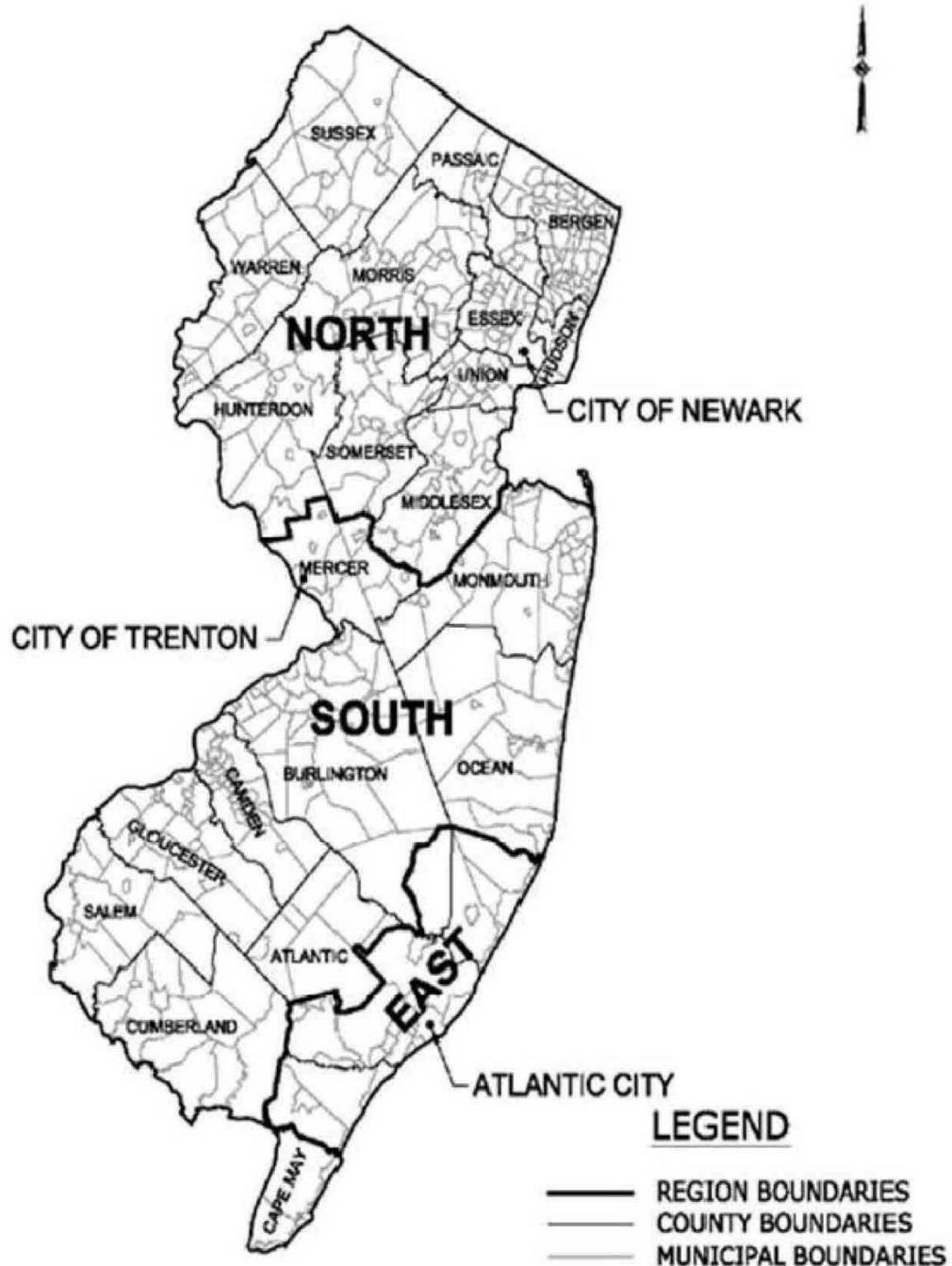
East Region: The eastern region is all municipalities east of the line delineated by the South municipal boundary of Sea Isle City, Cape May County to the South and Western boundary of Dennis Township, Cape May County to the western boundaries of Upper Township, Cape May County and Estell Manor City, Atlantic County to the West and North boundary of Weymouth Township, Atlantic County to the North boundary of Estell Manor City, Atlantic County to the North and East boundary of Weymouth Township, Atlantic County to the North boundary of Egg Harbor Township, Atlantic County to the East and North boundary of Galloway Township, Atlantic County to the North boundary of Port Republic City, Atlantic County to the East and North boundary of Bass River Township, Burlington County to the North boundary of Stafford Township, Ocean County to the East and North boundary of Harvey Cedars Boro, Ocean County.

The I-D-F curves provided were determined from data from the NOAA Atlas 14, Volume 2, Precipitation-Frequency of the United States. Development of Intensity-Duration-Frequency (I-D-F) curves is currently available in a number of computer programs. The programs develop an I-D-F curve based on user-supplied data or select the data from published data such as Hydro-35 or the aforementioned NOAA Atlas 14, Volume 2. Appendix A of HEC-12 contains an example of the development of rainfall intensity curves and equations.

Use of computer program-generated I-D-F curves shall be accepted provided the results match those obtained from Figures 10-B through 10-D.

FIGURE 10-A: RAINFALL INTENSITY - DURATION FREQUENCY CURVE

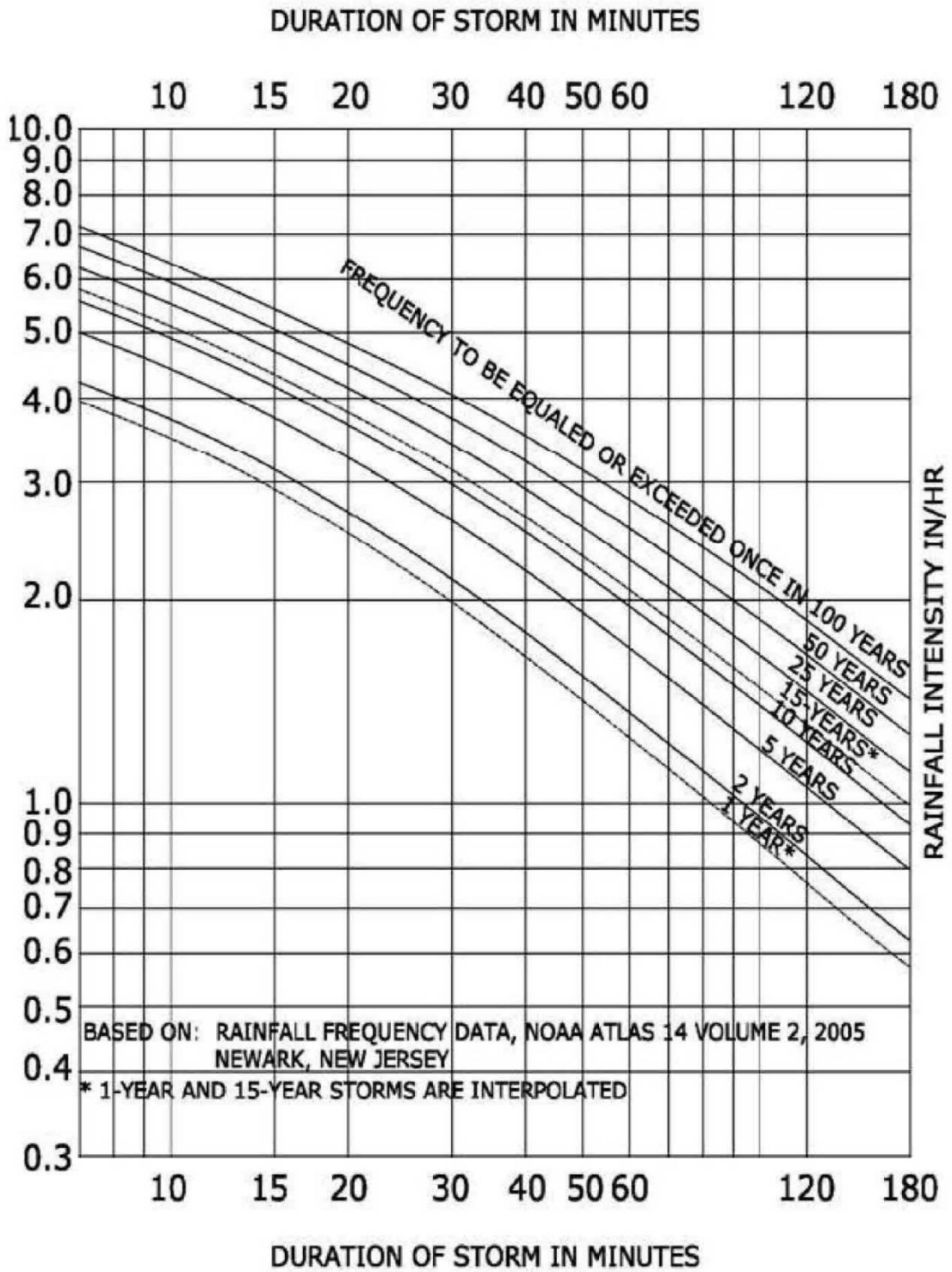
DELINEATED REGIONS WITH UNIFORM INTENSITY



DELINEATED REGIONS WITH UNIFORM INTENSITY

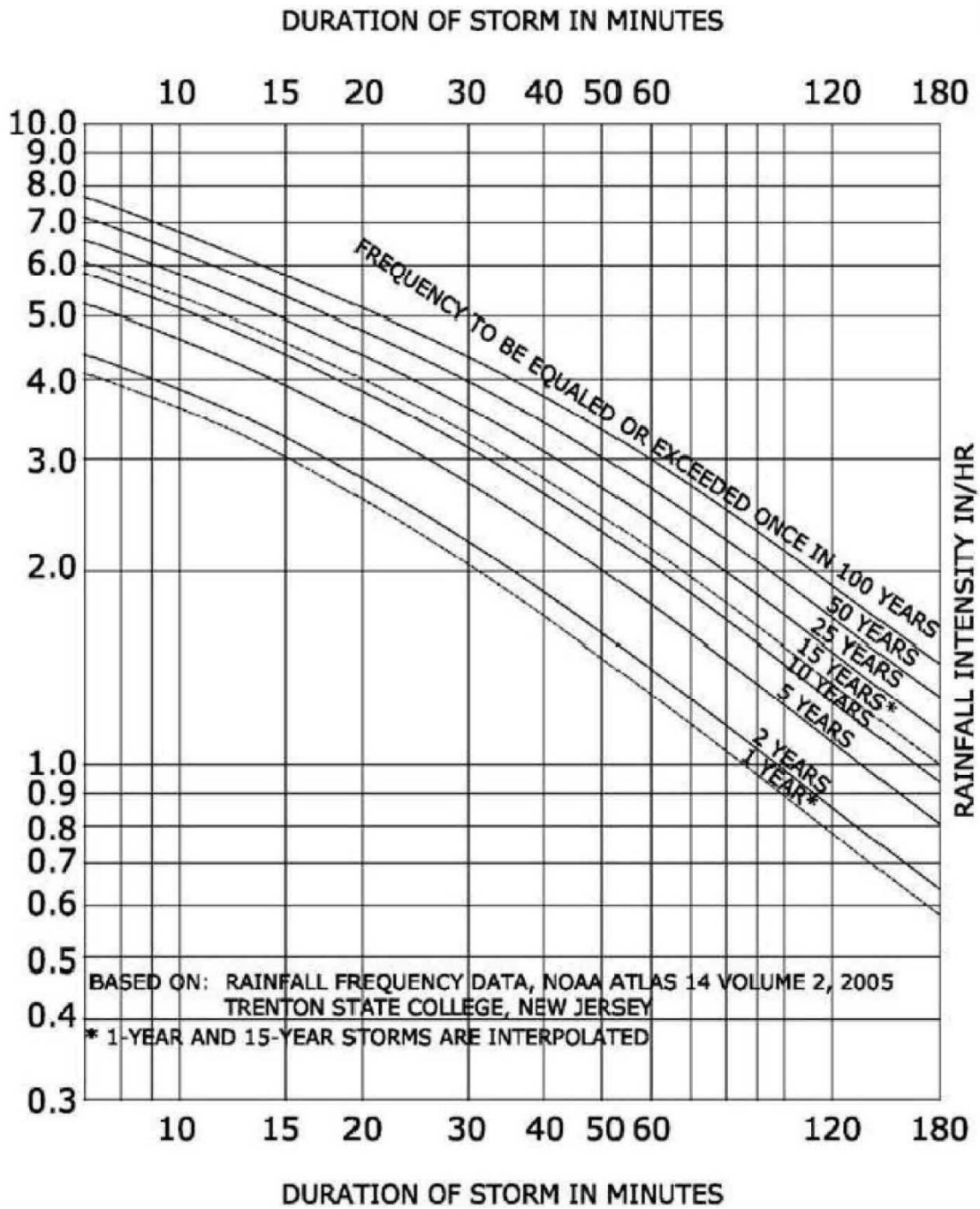
REV. DATE: JUNE 30, 2015

**FIGURE 10-B:
RAINFALL INTENSITY-DURATION FREQUENCY CURVE -
NORTHERN REGION**



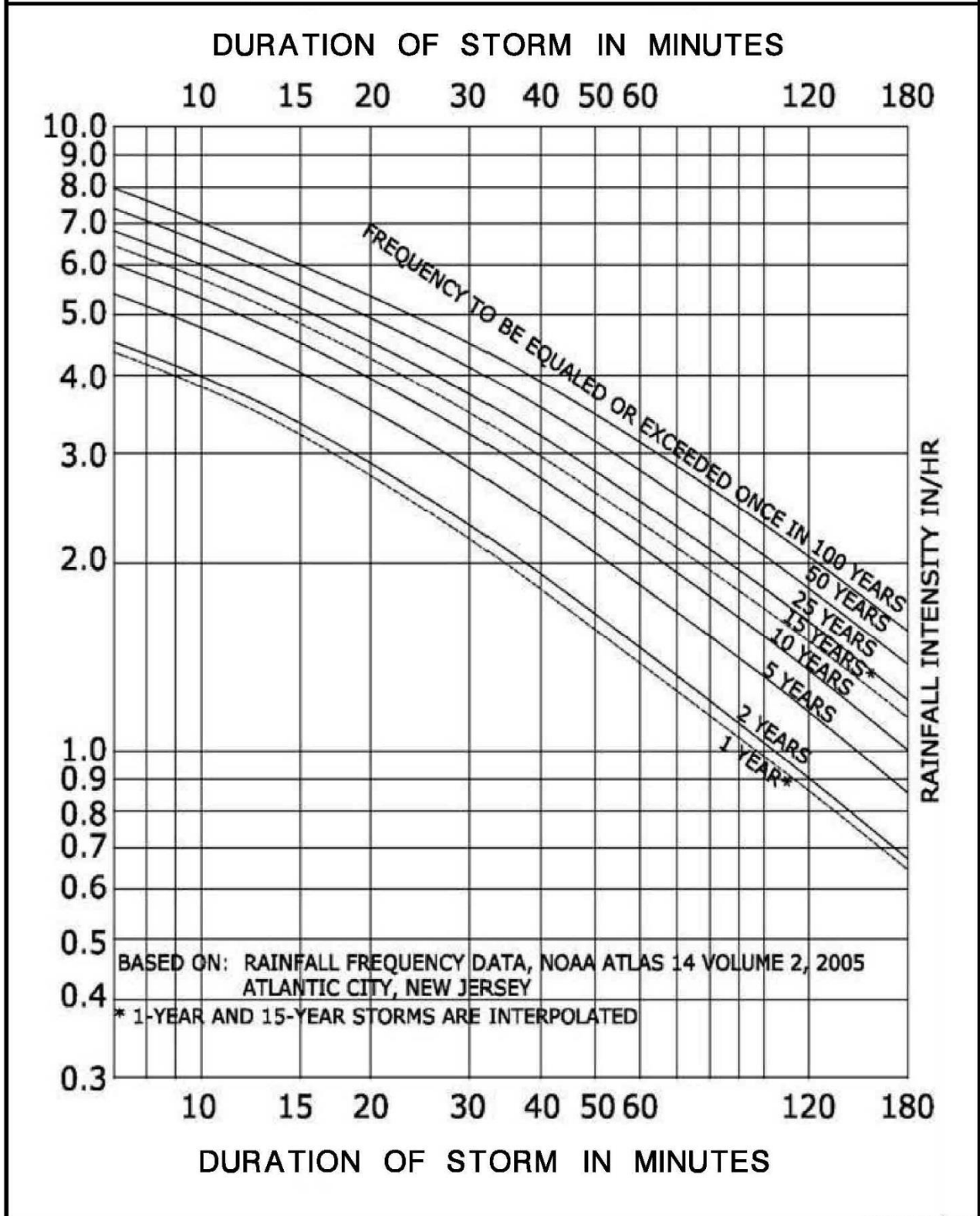
REV. DATE: JUNE 30, 2015

**FIGURE 10-C:
RAINFALL INTENSITY-DURATION
FREQUENCY CURVES – SOUTHERN REGION**



REV. DATE: JUNE 30, 2016

**FIGURE 10-D:
RAINFALL INTENSITY-DURATION
FREQUENCY CURVES - EASTERN REGION**



REV. DATE: JUNE 30, 2016

10.3.4 US Natural Resources Conservation Service (NRCS) Methodology

Techniques developed by the US Natural Resources Conservation Service (NRCS), formerly the US Soil Conservation Service (SCS) for calculating rates of runoff require the same basic data as the Rational Method: drainage area, a runoff factor, Time of Concentration, and rainfall. The NRCS approach, however, is more sophisticated in that it considers also the time distribution of the rainfall, the initial rainfall losses to interception and depression storage, and an infiltration rate that decreases during the course of a storm. With the NRCS method, the direct runoff can be calculated for any storm, either real or fabricated, by subtracting infiltration and other losses from the rainfall to obtain the precipitation excess. Details of the methodology can be found in the NRCS National Engineering Handbook, Section 4.

Two types of hydrographs are used in the NRCS procedure, unit hydrographs and dimensionless hydrographs. A unit hydrograph represents the time distribution of flow resulting from 1 inch of direct runoff occurring over the watershed in a specified time. A dimensionless hydrograph represents the composite of many unit hydrographs. The dimensionless unit hydrograph is plotted in nondimensional units of time versus time to peak and discharge at any time versus peak discharge.

Characteristics of the dimensionless hydrograph vary with the size, shape, and slope of the tributary drainage area. The most significant characteristics affecting the dimensionless hydrograph shape are the basin lag and the peak discharge for a specific rainfall. Basin lag is the time from the center of mass of rainfall excess to the hydrograph peak. Steep slopes, compact shape, and an efficient drainage network tend to make lag time short and peaks high; flat slopes, elongated shape, and an inefficient drainage network tend to make lag time long and peaks low.

The NRCS method is based on a 24-hour storm event which has a certain storm distribution. The Type III storm distribution should be used for the State of New Jersey. To use this distribution it is necessary for the user to obtain the 24-hour rainfall value for the frequency of the design storm desired. The 24-hour rainfall values for each county in New Jersey can be obtained from the NRCS and are contained in Table 10-5:

Table 10-5
New Jersey 24-Hour Rainfall Frequency Data
Rainfall amounts in Inches

County	Rainfall Frequency Data						
	1-Year	2-Year	5-Year	10-Year	25-Year	50-Year	100-Year
Atlantic	2.8	3.3	4.3	5.2	6.5	7.6	8.9
Bergen	2.8	3.3	4.3	5.1	6.3	7.3	8.4
Burlington	2.8	3.4	4.3	5.2	6.4	7.6	8.8
Camden	2.8	3.3	4.3	5.1	6.3	7.3	8.5
Cape May	2.8	3.3	4.2	5.1	6.4	7.5	8.8
Cumberland	2.8	3.3	4.2	5.1	6.4	7.5	8.8
Essex	2.8	3.4	4.4	5.2	6.4	7.5	8.7
Gloucester	2.8	3.3	4.2	5.0	6.2	7.3	8.5
Hudson	2.7	3.3	4.2	5.0	6.2	7.2	8.3
Hunterdon	2.9	3.4	4.3	5.0	6.1	7.0	8.0
Mercer	2.8	3.3	4.2	5.0	6.2	7.2	8.3
Middlesex	2.8	3.3	4.3	5.1	6.4	7.4	8.6
Monmouth	2.9	3.4	4.4	5.2	6.5	7.7	8.9
Morris	3.0	3.5	4.5	5.2	6.3	7.3	8.3
Ocean	3.0	3.4	4.5	5.4	6.7	7.9	9.2
Passaic	3.0	3.5	4.4	5.3	6.5	7.5	8.7
Salem	2.8	3.3	4.2	5.0	6.2	7.3	8.5
Somerset	2.8	3.3	4.3	5.0	6.2	7.2	8.2
Sussex	2.7	3.2	4.0	4.7	5.7	6.6	7.6
Union	2.8	3.4	4.4	5.2	6.4	7.5	8.7
Warren	2.8	3.3	4.2	4.9	5.9	6.8	7.8

Central to the NRCS methodology is the concept of the Curve Number (CN) which relates to the runoff depth and is itself characteristic of the soil type and the surface cover. CN's in Table 2-2 (a to d) of the TR-55 Manual (June 1986) represent average antecedent runoff condition for urban, cultivated agricultural, other agricultural, and arid and semiarid rangeland uses. Infiltration rates of soils vary widely and are affected by subsurface permeability as well as surface intake rates. Soils are classified into four Hydrologic Soil Groups (A, B, C, and D) according to their minimum infiltration rate. Appendix A of the TR-55 Manual defines the four groups and provides a list of most of the soils in the United States and their group classification. The soils in the area of interest may be identified from a soil survey report, which can be obtained from the local Soil Conservation District offices.

Several techniques have been developed and are currently available to engineers for the estimation of runoff volume and peak discharge using the NRCS methodology. Some of the more commonly used of these methods are summarized below:

- A. NRCS Technical Release 55 (TR-55): The procedures outlined in this document are the most widely used for the computation of stormwater runoff. This methodology is particularly useful for the comparison of pre- and post-development runoff rates and consequently for the design of control structures. There are basically two variations of this technique: the Tabular Hydrograph method and the Graphical Peak Discharge method.
1. The Tabular Method – This method provides an approximation of the more complicated NRCS TR-20 method. The procedure divides the watershed into subareas, completes an outflow hydrograph for each sub area and then combines and routes these hydrographs to the watershed outlet. This method is particularly useful for measuring the effects of changed land use in a part of the watershed. The Tabular method should not be used when large changes in the curve number occur among sub areas or when runoff flow rates are less than $1345 \text{ ft}^3/\text{s}$ for curve numbers less than 60. However, this method is sufficient to estimate the effects of urbanization on peak rates of discharge for most heterogeneous watersheds.
 2. Graphical Peak Discharge Method – This method was developed from hydrograph analysis using TR-20, "*Computer Program for Project Formulation-Hydrology*" (NRCS 1983). This method calculates peak discharge using an assumed hydrograph and a thorough and rapid evaluation of the soils, slope and surface cover characteristics of the watershed. The Graphical method provides a determination of peak discharge only. If a hydrograph is required or subdivision is needed, the Tabular Hydrograph method should be used. This method should not be used if the weighted CN is less than 40.

For a more detailed account of these methods and their limitations the design engineer is referred to the NRCS TR-55 document.

- B. US Army Corps of Engineers HEC-1 Model: This model is used to simulate watershed precipitation runoff processes during flood events. The model may be used to simulate runoff in a simple single basin watershed or in a highly complex basin with a virtually unlimited number of sub-basins and for routing interconnecting reaches. It can also be used to analyze the impact of changes in land use and detention basins on the downstream reaches. It can serve as a useful tool in comprehensive river basin planning and in the development of area-wide watershed management plans. The NRCS Dimensionless Unitgraph Option in the HEC-1 program shall be used. Other synthetic unit hydrograph methods available in HEC-1 can be used with the approval of the Department.

The HEC-1 model is currently supported by a number of software vendors which have enhanced versions of the original US Army Corps HEC-1 model. Refer to the available Program Documentation Manual for additional information.

- C. The NRCS TR-20 Model: This computer program is a rainfall-runoff simulation model which uses a storm hydrograph, runoff curve number and channel features to determine runoff volumes as well as unit hydrographs to estimate peak rates of discharge. The dimensionless unit hydrographs from sub-basins within the watershed can be routed through stream reaches and impoundments. The TR-20 method may be used to analyze the impact of development and detention basins on downstream areas. The parameters needed in this method include total

rainfall, rainfall distribution, curve numbers, Time of Concentration, travel time and drainage area.

10.3.5 Time of Concentration (T_c)

The Time of Concentration (T_c) is the time for runoff to travel from the hydraulically most distant point of the watershed to a point of interest within the watershed. It may take a few computations at different locations within the drainage area to determine the most hydraulically distant point. T_c is computed by summing all the travel times for consecutive components of the drainage conveyance system.

T_c influences the shape and peak of the runoff hydrograph. Development usually decreases the T_c , thereby increasing the peak discharge, but T_c can be increased as a result of (a) ponding behind small or inadequate drainage systems, including storm drain inlets and road culverts, or (b) reduction of land slope through grading.

A. Factors Affecting Time of Concentration and Travel Time

1. **Surface Roughness:** One of the most significant effects of development on flow velocity is less retardance of flow. That is, undeveloped areas with very slow and shallow overland flow through vegetation become modified by development; the flow is then delivered to streets, gutters, and storm sewers that transport runoff downstream more rapidly. Travel time through the watershed is generally decreased.
2. **Channel Shape and Flow Patterns:** In small watersheds, much of the travel time results from overland flow in upstream areas. Typically, development reduces overland flow lengths by conveying storm runoff into a channel as soon as possible. Since channel designs have efficient hydraulic characteristics, runoff flow velocity increases and travel time decreases.
3. **Slope:** Slopes may be increased or decreased by development, depending on the extent of site grading or the extent to which storm sewers and street ditches are used in the design of the storm water management system. Slope will tend to increase when channels are straightened and decrease when overland flow is directed through storm sewers, street gutters, and diversions.

- B. **Computation of Travel Time and Time of Concentration:** Water moves through a watershed as sheet flow, street/gutter flow, pipe flow, open channel flow, or some combination of these. Sheet flow is sometimes commonly referred to as overland flow. The type of flow that occurs is a function of the conveyance system and is best determined by field inspection, review of topographic mapping and subsurface drainage plans.

A brief overview of methods to compute travel time for the components of the conveyance system is presented below.

1. **Rational Method:** Travel time for each flow regime shall be calculated as described below:
 - a. **Sheet Flow:** Using the slope and land cover type, determine the velocity from Figures 10-D and 10-E. Sheet flow can only be computed for flow distances of 100 feet or less and for slopes of 24% or less.

- b. Gutter Flow: The gutter flow component of Time of Concentration can be computed using the velocity obtained from the Manning equation for the triangular gutter of a configuration and longitudinal slope as indicated by roadway geometry.
- c. Pipe Flow: Travel time in a storm sewer can be computed using full flow velocities for the reach as appropriate.
- d. Open Channel Flow: Travel time in an open channel such as a natural stream, swale, man-made ditch, etc., can be computed using the velocity obtained from the Manning equation or other acceptable computational procedure for open channel flow such as HEC-2.

Time of concentration (T_c) is the sum of travel time (T_t) values for the various consecutive flow segments:

$$T_c = T_{t1} + T_{t2} + \dots + T_{tm}$$

where:

T_c = total Time of Concentration

T_t = travel time for each flow segment

m = number of flow segments

2. TR-55: The NRCS TR-55 method separates the flow into three basic segments: sheet flow, shallow concentrated flow, and open channel. The maximum length of sheet flow to be used is 150 feet. The open channel portion may be a natural channel, man-made ditch, or gutter flow along the roadway. The open channel portion time is determined by using the Manning's equation or other acceptable procedure for open channel flow such as HEC-2. Refer to TR-55, Chapter 3 for detailed information on the procedures.

The minimum Time of Concentration used shall be 10 minutes.

10.3.6 Flood Routing

The traditional design of storm drainage systems has been to collect and convey storm runoff as rapidly as possible to a suitable location where it can be discharged. This type of design may result in major drainage and flooding problems downstream. Under favorable conditions, the temporary storage of some of the storm runoff can decrease downstream flows and often the cost of the downstream conveyance system. Flood routing shall be used to document the required storage volume to achieve the desired runoff control.

A hydrograph is required to accomplish the flood routing. A hydrograph represents a plot of the flow, with respect to time. The predicted peak flow occurs at the time, T_c . The area under the hydrograph represents the total volume of runoff from the storm. A hydrograph can be computed using either the Modified Rational Method (for drainage areas up to 20 acres) or the Soil Conservation Service 24-hour storm methodology described in previous sections. The Modified Rational Method is described in detail in Appendix A-9 of the NJDOT's Soil Erosion and Sediment Control Standards.

Storage may be concentrated in large basin-wide regional facilities or distributed throughout the watershed. Storage may be developed in roadway interchanges, parks and other recreation areas, small lakes, ponds and depressions. The utility of any

storage facility depends on the amount of storage, its location within the system, and its operational characteristics. An analysis of such storage facilities should consist of comparing the design flow at a point or points downstream of the proposed storage site with and without storage. In addition to the design flow, other flows in excess of the design flow that might be expected to pass through the storage facility should be included in the analysis. The design criteria for storage facilities should include:

- release rate,
- storage and volume,
- grading and depth requirements,
- outlet works, and
- location

Control structure release rates shall be in accordance with criteria outlined in Subsection 10.2, Drainage Policy. Multi-stage control structures may be required to control runoff from different frequency events.

Storage volume shall be adequate to meet the criteria outlined in Subpart 10.2.2, Stormwater Management and Non-Point Source Pollution Control, to attenuate the post-development peak discharge rates or Subpart 10.2.3 to meet the allowable water surface elevation.

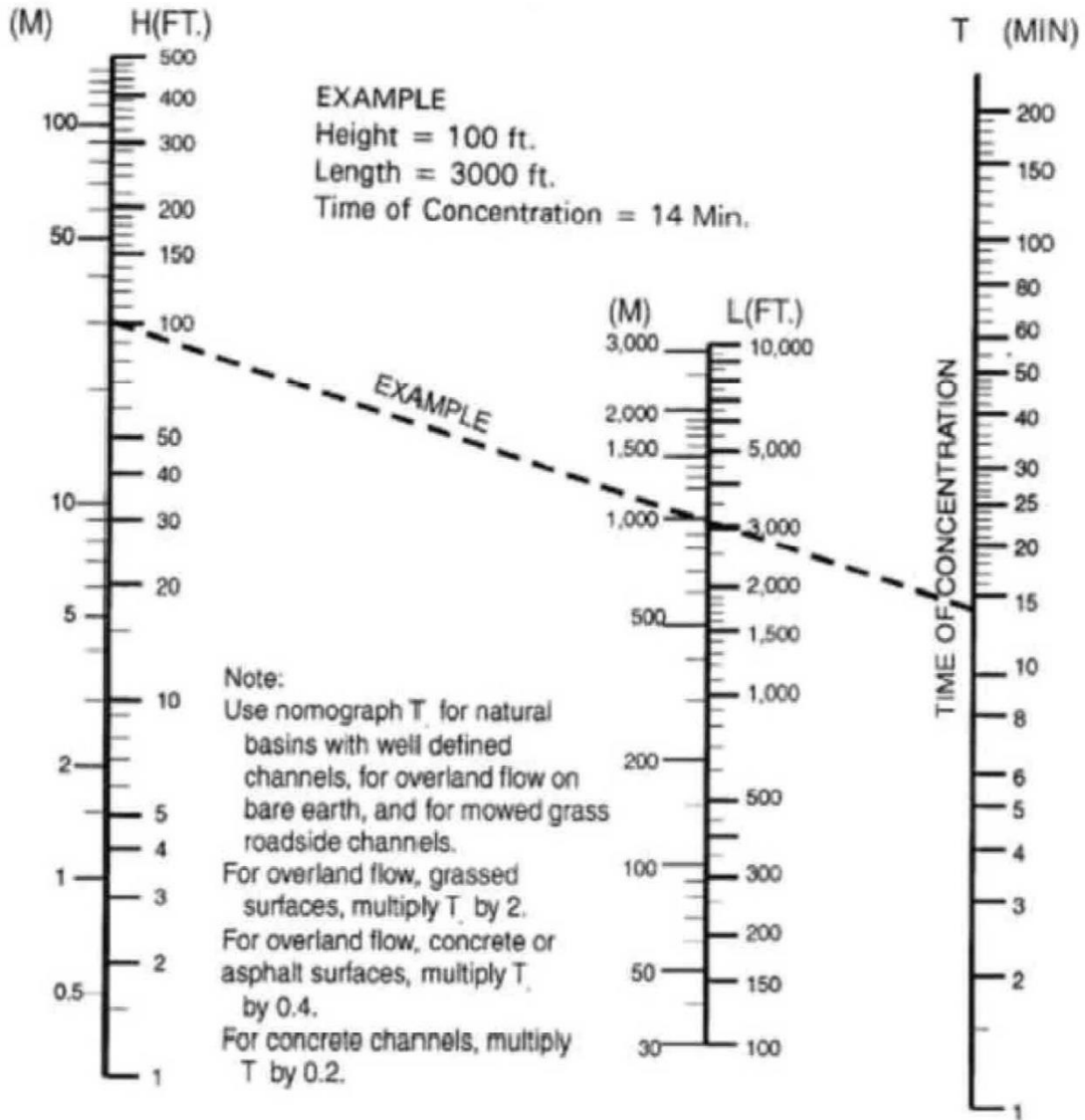
Outlet works selected for storage facilities typically include a principal spillway and an emergency overflow, and must be able to accomplish the design functions of the facility. Outlet works can take the form of combinations of drop inlets, pipes, weirs, and orifices. Standard acceptable equations such as the orifice equation ($Q = CA(2GH)^{1/2}$) or the weir equation ($Q = CL(H)^{3/2}$) shall be used to calculate stage-discharge relationships required for flood routings. The total stage-discharge curve shall take into account the discharge characteristics of all outlet works. Detailed information on outlet hydraulics can be found in the "Handbook of Hydraulics", by Brater and King.

Stormwater storage facilities are often referred to as either detention or retention facilities. For the purposes of this section, detention facilities are those that are designed to reduce the peak discharge and detain the quantity of runoff required to achieve this objective for a relatively short period of time. These facilities are designed to completely drain after the design storm has passed. Retention facilities are designed to contain a permanent pool of water. Since most of the design procedures are the same for detention and retention facilities, the term storage facilities will be used in this chapter to include detention and retention facilities.

Routing calculations needed to design storage facilities, although not extremely complex, are time consuming and repetitive. Many reservoir routing computer programs, such as HEC-1, TR-20 and Pond-2, are available to expedite these calculations. Use of programs to perform routings is encouraged.

Subsections 10.11 and 10.12 contain standards related to stormwater management and quality control.

**FIGURE 10-E:
TIME OF CONCENTRATION-OVERLAND FLOW
(FOR USE IN RATIONAL FORMULA)**



Based on study by P.Z. Kirpich,
Civil Engineering, Vol. 10, No.6, June 1940, p.362

REV. DATE: JUNE 30, 2015

10.4 Channel Design

10.4.1 Introduction

Open channels, both natural and artificial, convey flood waters. Natural channels are crossed at highway sites and often need to be modified to accommodate the construction of a modern highway. Channels in the form of roadside ditches are added to the natural drainage pattern.

This part contains design methods and criteria to aid the design engineer in preparing designs incorporating these factors. Other open channel analysis methods and erosion protection information is also included.

10.4.2 Channel Type

The design of a channel is formulated by considering the relationship between the design discharge, the shape, slope and type of material present in the channel's bank and bed. Either grassed channels or non-erodible channels are typically used. Environmental and permitting consideration should also be taken into account. The features of each are presented in the following narrative.

- A. **Grassed Channels:** The grassed channel is protected from erosion by a turf cover. It is used in highway construction for roadside ditches, medians, and for channel changes of small watercourses. A grassed channel has the advantage of being compatible with the natural environment. This type of channel should be selected for use whenever possible.
- B. **Non-erodible Channel:** A non-erodible channel has a lining that is highly resistant to erosion. This type of channel is expensive to construct, although it should have a very low maintenance cost if properly designed. Non-erodible lining should be used when stability cannot be achieved with a grass channel. Typical lining materials are discussed in the following narrative.
 - 1. **Concrete Ditch Lining:** Concrete ditch lining is extremely resistant to erosion. Its principal disadvantages are high initial cost, susceptibility to failure if undermined by scour and the tendency for scour to occur downstream due to an acceleration of the flow velocity on a steep slope or in critical locations where erosion would cause extensive damage.
 - 2. **Aggregate Ditch Lining:** This lining is very effective on mild slopes. It is constructed by dumping crushed aggregate into a prepared channel and grading to the desired shape. The advantages are low construction cost and self-healing characteristics. It has limited application on steep slopes where the flow will tend to displace the lining material.
 - 3. **Alternative Linings:** Other types of channel lining such as gabion, or an articulated block system may be approved by the Department on a case-by-case basis, especially for steep sloped high velocity applications. HEC-11, Design of Riprap Revetment provides some design information on other types of lining.

10.4.3 Site Application

The design should consider site conditions as described below.

- A. **Road Ditches:** Road ditches are channels adjacent to the roadway used to intercept runoff and groundwater occurring from areas within and adjacent to the right-of-

way and to carry this flow to drainage structures or to natural waterways. Road ditches should be grassed channels except where non-erodible lining is warranted. A minimum desirable slope of 0.5% should be used.

- B. **Interceptor Ditch:** Interceptor ditches are located on the natural ground near the top edge of a cut slope or along the edge of the right-of-way to intercept runoff from a hillside before it reaches the backslope.

Interceptor ditches should be built back from the top of the cut slope, and generally at a minimum slope of 0.5% until the water can be emptied into a natural water course or brought into a road ditch or inlet by means of a headwall and pipe. In potential slide areas, stormwater should be removed as rapidly as practicable and the ditch lined if the natural soil is permeable.

- C. **Channel Changes:** Realignment or changes to natural channels should be held to a minimum. The following examples illustrate conditions that warrant channel changes:

1. The natural channel crosses the roadway at an extreme skew.
2. The embankment encroaches on the channel.
3. The natural channel has inadequate capacity.
4. The location of the natural channel endangers the highway embankment or adjacent property.

- D. **Grade Control Structure:** A grade control structure allows a channel to be carried at a mild grade with a drop occurring through the structure (check dam).

10.4.4 Channel Design Procedure

The designed channel must have adequate capacity to convey the design discharge with 1 foot of freeboard.

Methods to design grass-lined and non-erodible channels are presented in the following narrative.

- A. **Grassed Channel:** A grassed channel shall have a capacity designated in Subpart 10.2.4 – Recurrence Interval.

A non-erodible channel should be used in locations where the design flow would cause a grassed channel to erode.

The design of the grassed channel shall be in accordance with the NJDOT Soil Erosion and Sediment Control Standards Manual.

- B. **Non-Erodible Channels:** Non-erodible channels shall have a capacity as designated in Subpart 10.2.4 – Recurrence Interval. The unlined portion of the channel banks should have a good stand of grass established so large flows may be sustained without significant damage.

The minimum design requirements of non-erodible channels shall be in accordance with the NJDOT Soil Erosion and Sediment Control Standards Manual where appropriate unless otherwise stated in this section.

1. **Capacity:** The required size of the channel can be determined by use of the Manning's equation for uniform flow. Manning's formula gives reliable results if the channel cross section, roughness, and slope are fairly constant over a

sufficient distance to establish uniform flow. The Manning's equation is as follows:

$$Q = \frac{1.486 AR^{2/3}S^{1/2}}{n}$$

where

Q = Flow, cubic feet per second (ft³/s)

n = Manning's roughness coefficient

<u>Concrete, with surface as indicated:</u>	<u>Friction Factor Range</u>
1. Formed, no finish	0.013-0.017
2. Trowel finish	0.012-0.014
3. Float finish	0.013-0.015
4. Float finish, some gravel on bottom	0.015-0.017
5. Gunite, good section	0.016-0.019
6. Gunite, wavy section	0.016-0.022

A = Area, square feet (ft²)

P = Wetted perimeter, feet (ft)

R = Hydraulic radius (A/P)

S = Slope (ft/ft)

Design manuals such as Hydraulic Design Series No. 3 and No. 4 can be used as a reference for the design of the channels.

For non-uniform flow, a computer program, such as HEC-2, should be used to design the channel.

2. Height of Lining: The height of the lined channel should be equal to the normal depth of flow (D) based on the design flow rate, plus 1 foot for freeboard if possible.
3. Horizontal Alignment: Water tends to superelevate and cross waves are formed at a bend in a channel. If the flow is supercritical (as it will usually be for concrete-lined channels), this may cause the flow to erode the unlined portion of the channel on the outside edge of the bend. This problem may be alleviated either by superelevating the channel bed, adding freeboard to the outside edge, or by choosing a larger radius of curvature. The following equation relates freeboard to velocity, width, and radius of curvature:

$$H = \frac{V^2 W}{32.2 R_c}$$

where

H = Freeboard in feet (ft.)

V = Velocity in ft/s

W = Bottom width of channel in feet (ft.)

R_c = Radius of curvature in feet (ft.)

4. Additional Design Requirements:

- a. The minimum d_{50} stone size shall be 6 inches.
- b. The filter layer shall be filter fabric wherever possible.
- c. A 3 feet wide by 3 feet deep cutoff wall extending a minimum of 3 feet below the channel bed shall be provided at the upstream and downstream limits of the non-erodible channel lining.
- d. Additional design requirements may be required for permit conditions or as directed by the Department.
- e. Gradation of Aggregate Lining: The American Society of Civil Engineers Subcommittee recommends the following rules as to the gradation of the stone:
 1. Stone equal to or larger than the theoretical d_{50} , with a few larger stones, up to about twice the weight of the theoretical size tolerated for reasons of economy in the utilization of the quarried rock, should make up 50 percent of the rock by weight.
 2. If a stone filter blanket is provided, the gradation of the lower 50 percent should be selected to satisfy the filter requirements between the stone and the upper layer of the filter blanket.
 3. The depth of the stone should accommodate the theoretically sized stone with a tolerance in surface in rule 1. (This requires tolerance of about 30 percent of the thickness of the stone.)
 4. Within the preceding limitations, the gradation from largest to smallest sizes should be quarry run.

C. Water Quality Channel Design: The design of a water quality channel shall be in accordance with NJDOT and NJDEP requirements. Detailed requirements regarding water quality control is included in Subsection 10.12 Water Quality.

10.5 Drainage of Highway and Pavements

10.5.1 Introduction

Effective drainage of highway pavements is essential to maintenance of the service level of highways and to traffic safety. Water on the pavement slows traffic and contributes to accidents from hydroplaning and loss of visibility from splash and spray. Free-standing puddles which engage only one side of a vehicle are perhaps the most hazardous because of the dangerous torque levels exerted on the vehicle. Thus, the design of the surface drainage system is particularly important at locations where ponding can occur.

10.5.2 Runoff Collection and Conveyance System Type

Roadway runoff is collected in different ways based on the edge treatment, either curbed or uncurbed. Runoff collection and conveyance for a curbed roadway is typically provided by a system of inlets and pipe, respectively. Runoff from an uncurbed roadway, typically referred to as "an umbrella section", proceeds overland away from the roadway in fill sections or to roadside swales or ditches in roadway cut sections.

Conveyance of surface runoff over grassed overland areas or swales and ditches allows an opportunity for the removal of contaminants. The ability of the grass to prevent erosion is a major consideration in the design of grass-covered facilities. Use of an "umbrella" roadway section may require additional ROW.

Areas with substantial development adjacent to the roadway, particularly in urbanized areas, typically are not appropriate for use of a roadway "umbrella" section.

The decision to use an "umbrella" section requires careful consideration of the potential problems. Benefits associated with "umbrella" sections include cost savings and eliminating the possibility of vehicle vaulting. "Umbrella" sections used on roadways with higher longitudinal slopes have been found to be prone to berm washouts. Debris build-up along the edge of the roadway creates a curb effect that prevents sheet flow and directs the water along the edge of the roadway. This flow usually continues along the edge until a breach is created, often resulting in substantial erosion. Some situations may also warrant installing inlets along the edge of an "umbrella" section to pick up water which may become trapped by berm buildup or when snow is plowed to the side of the roadway and creates a barrier that will prevent sheet flow from occurring.

Bermed sections are designed with a small earth berm at the edge of the shoulder to form a gutter for the conveyance of runoff. Care should be taken to avoid earth berms on steep slopes that would cause erosive velocities yielding berm erosion.

An "umbrella" section should be used where practical. However, low points at umbrella sections should have inlets and discharge pipes to convey the runoff safely to the toe of slope. A Type "E" inlet and minimum 15 inch diameter pipe shall be used to drain the low point. Snow inlets (see Subpart 10.5.12) shall be provided where the pile up of snow in the berm area prevents drainage of the low points.

"Umbrella" sections should be avoided on land service roadways where there are abutting properties and driveways.

Slope treatment shall be provided at all low points of umbrella sections and all freeway and interstate projects to provide erosion protection (see NJDOT Standard Details).

10.5.3 Types of Inlets Used by NJDOT

Inlet grate types used by NJDOT consist of two types, combination inlets (with a curb opening), and grate inlets (without a curb opening) as shown on the current standard details as summarized below:

1. Combination Inlets B, B1, B2, C, D1, D2
2. Grate Inlets A, B Mod., B1 Mod., B2 Mod., E, E1, E2, ES

Inlets Type B1, B2, B1 Modified, B2 Modified, E1 or E2 will be used as necessary to accommodate large longitudinal pipes. A special inlet shall be designed, with the appropriate detail provided in the construction plans, and the item shall be designated "Special Inlet", when the pipe size requires a structure larger than a Type B2, B2 Modified or E2. A special inlet shall also be designed, with the appropriate detail provided in the construction plans, and the item shall be designated "Special Inlet", when the transverse pipe size requires a structure larger than the standard inlet types.

Drainage structure layout should minimize irregularities in the pavement surface. Manholes should be avoided where practicable in the traveled way and shoulder. An example is a widening project where inlets containing a single pipe should be demolished and the pipe extended to the proposed inlet, as opposed to placing a slab with a standard manhole cover or square frame with round cover on the existing inlet and extending the pipe to the new inlet.

10.5.4 Flow in Gutters (Spread)

The hydraulic capacity of a gutter depends on its cross-section geometry, longitudinal grade, and roughness. The typical curbed gutter section is a right triangular shape with the curb forming the vertical leg of the triangle. Design shall be based on the following frequencies:

Recurrence Interval	Facility Description
15-Year	Freeway or interstate highway
10-Year	Land service highway

The Manning equation has been modified to allow its use in the calculation of curbed gutter capacity for a triangular shaped gutter. The resulting equation is:

$$Q = (0.56/n)(S_x^{5/3})(S_o^{1/2}) T^{8/3} \quad (1)$$

where

Q = rate of discharge in ft³/s

n = Manning's coefficient of gutter roughness
(Table 10-6)

S_x = cross slope, in ft/ft

S_o = longitudinal slope, in ft/ft

T = spread or width of flow in feet

The relationship between depth of flow (*y*), spread (*T*), and cross slope (*S_x*) is as follows:

$$y = TS_x, \text{ depth in gutter, at deepest point in feet}$$

Table 10-6
Roughness Coefficients
Manning's "n"

Street and Expressway Gutters		
a.	Concrete gutter troweled finish	0.012
b.	Asphalt pavement 1) Smooth texture 2) Rough texture	0.013 0.016
c.	Concrete gutter with asphalt pavement 1) Smooth 2) Rough	0.013 0.015
d.	Concrete pavement 1) Float finish 2) Broom finish	0.014 0.016
e.	Brick	0.016
For gutters with small slope where sediment may accumulate, increase all above values of "n" by 0.002.		

10.5.5 Limits of Spread

The objective in the design of a drainage system for a highway pavement section is to collect runoff in the gutter and convey it to pavement inlets in a manner that provides reasonable safety for traffic and pedestrians at a reasonable cost. As spread from the curb increases, the risks of traffic accidents and delays and the nuisance and possible hazard to pedestrian traffic increase. The following shall be used to determine the allowable spread.

- Width of inside and outside shoulder along interstate and freeway mainline
- 1/3 width of ramp proper, 1/3 of live lanes next to curb and lanes adjacent to inside and outside shoulders on land service roads
- 1/2 width of acceleration or deceleration lanes

The limits of spread are summarized in Table 10-7.

**Table 10-7
Limits of Spread**

Lane Configuration	Interstate and Freeways	Land Service Roads
Live Lanes next to Shoulder (inside & outside)	Full Shoulder	1/3 Width of Lane
Live Lanes next to Curb	---	1/3 Width of Lane
Ramp Proper	1/3 Width of Ramp	1/3 Width of Ramp
Accel/Decel Lanes	1/2 Width of Lane	1/2 Width of Lane

10.5.6 Inlets

There are separate design standards for grates in pavement or other ground surfaces, and for curb opening inlets. Each standard is described below. These standards help prevent certain solids and floatables (e.g., cans, plastic bottles, wrappers, and other litter) from reaching the surface waters of the State. For new roadway projects and reconstruction of existing highway, storm drain inlets must be selected to meet the following design requirements. In addition, retrofitting of existing storm drainage inlets to these standards is required where such inlets are in direct contact with repaving, repairing (excluding repair of individual potholes), reconstruction or alterations of facilities owned or operated by the Highway Agency (unless the inlets already meet the requirements).

A. Grates in Pavement or Other Ground Surfaces

Many grate designs meet the standard. The first option (especially for storm drain inlets along roads) is simply to use the Department's bicycle safe grate. The other option is to use a different grate, as long as each "clear space" in the grate (each individual opening) is:

- No larger than seven (7.0) square inches; or
- No larger than 0.5 inches (1/2 inch) across the smallest dimension (length or width).

B. Curb-Opening Inlets

If the storm drain inlet has a curb opening, the clear space in that curb opening (or each individual clear space, if the curb opening has two or more clear spaces) must be:

- No larger than two (2.0) inches across the smallest dimension (length or width) - many curb opening inlets installed in recent years meet this criterion; or
- No larger than seven (7.0) square inches

C. Exemptions

The requirements for Grates in Pavement or Other Ground Surfaces or Curb-Opening Inlets do not apply in certain circumstances. See the New Jersey Department of Environmental Protection Highway Agency Stormwater Guidance Document and the New Jersey Pollution Discharge Elimination System (NJPDES) Highway Agency Stormwater General Permit for a complete list of exemptions.

Storm Drain inlets that are located at rest areas, service areas, maintenance facilities, and along streets with sidewalks operated by the Department are required to have a label placed on or adjacent to the inlet. The label must contain a cautionary message about dumping pollutants. The message may be a short phrase and/or graphic approved by the Department. The message may be a short phrase such as "The Drain is Just for Rain", "Drains to [Local Waterbody]", "No Dumping. Drains to River", "You Dump it, You Drink it. No Waste Here". or it may be a graphic such as a fish. Although a stand-alone graphic is permissible, the Department strongly recommends that a short phrase accompany the graphic.

The hydraulic capacity of an inlet depends on its geometry and gutter flow characteristics. Inlets on grade demonstrate different hydraulic operation than inlets in a sump. The design procedures for inlets on grade are presented in Subpart 10.5.7, "Capacity of Gutter Inlets on Grade". The design procedures for inlets in a sump are presented in Subpart 10.5.8, "Capacity of Gutter Inlets at Low Points". Proper hydraulic design in accordance with the design criteria maximizes inlet capture efficiency and spacing. The inlet efficiency should be a minimum of 75%.

10.5.7 Capacity of Gutter Inlets on Grade

Collection capacity for gutter inlets on grade shall be determined using the following empirical equation:

$$Q_i = 16.88y^{1.54} (S^{0.233}/S_x^{0.276})$$

where

Q_i = flow rate intercepted by the grate (ft³/s)

y = gutter depth (ft) for the approach flow

S = longitudinal pavement slope

S_x = transverse pavement slope

The equation was developed for the standard NJDOT Type "A" grate configuration and is to be used for all inlet grate types without modification.

An alternative procedure, that yields results reasonably close to those obtained by using the runoff collection capacity equation presented above, is to compute the collection capacity in accordance with the procedures presented in Federal Highway Administration, Hydraulic Engineering Circular No. 12 (HEC-12) "Drainage of Highway Pavements" using the following parameter values:

- Grate type P-1-7/8-4
- Constant representative splash-over velocity of 5.77 ft/s
- Constant effective grate length of 2.66 feet
- All other parameter values for use in this procedure are as stated in HEC-12.

Use of computer programs is encouraged to perform the tedious hydraulic capacity calculations. HEC-12 contains useful charts and tables. The HEC-12 procedure is also incorporated in a number of computer software programs.

10.5.8 Capacity of Grate Inlets at Low Points

Hydraulic evaluation of the bicycle safe grate reveals that the grate functions as a weir for approach flow depths equal to or less than 9 inches and as an orifice for greater depths. Procedures to compute the collection capacity for each condition are presented separately below.

Weir Flow

Collection capacity shall be determined using equation 17 presented on page 69 of HEC-12:

$$Q_i = C_w P y^{1.5}$$

where

Q_i = flow rate intercepted by the grate (ft³/s)

C_w = weir coefficient

P = perimeter around the open area of the grate
(as shown on chart 11, on page 71 of HEC-12)

y = depth (ft) for the approach flow

The weir flow coefficient is 3.0. The perimeter around the open area for various NJDOT bicycle safe grate configurations and the resultant product of $C_w P$ are summarized as follows.

Inlet Type	Perimeter* (ft)	$C_w P^*$
A, B Mod., B1 Mod., B2 Mod.	5.28	15.84
B, B1, B2, C, D1, D2, E	6.96	20.88
ES	5.18	15.54

*Type "B", "C", and "D" inlets have a curb opening that allows runoff to enter the inlet even when debris partly clogs the grate. The equations must be modified for use with inlets that do not have a curb opening to account for reduced interception capacity resulting from debris collecting on the grate. The perimeter around the open area of the grate (P) used in the weir equation should be divided in half for inlets without a curb opening. The perimeter and resultant product of $C_w P$ for inlet types "A", "B Mod.", "E" and "ES" shown in the table reflect this modification.

Orifice Flow

Collection capacity shall be determined using equation 18 presented on page 69 of HEC-12 (1984):

$$Q_i = C_o A_o (2gy)^{0.5}$$

where

Q_i = flow rate intercepted by the grate (ft³/s)

C_o = orifice coefficient

A_o = clear opening area of a single grate

y = depth (ft) for the approach flow

g = gravitational acceleration of 32.2 ft/sec²

The orifice flow coefficient is 0.67. The clear opening area and resultant product of C_oA_o for various NJDOT bicycle safe grate configurations are summarized as follows:

Inlet Type	Clear Opening Area* (ft ²)	C_oA_o *
A, B Mod., B1 Mod., B2 Mod.	1.45	0.97
B, B1, B2, C, D1, D2, E, ES	2.90	1.94

*Type "B" "C", and "D" inlets have a curb opening that allows runoff to enter the inlet even when debris partly clogs the grate. The equations must be modified for use with inlets that do not have a curb opening to account for reduced interception capacity resulting from debris collecting on the grate. The clear opening area of the grate (A_o) used in the orifice equation should be divided in half for inlets without a curb opening. The clear opening area and resultant product of C_oA_o for inlet types "A", "B Mod.", "E" and "ES" reflect this modification.

10.5.9 Location of Inlets

Proper inlet spacing enhances safety by limiting the spread of water onto the pavement. Proper hydraulic design in accordance with the design criteria maximizes inlet capture efficiency and spacing. Inlets should be located primarily as required by spread computations. See Subparts 10.5.7 and 10.5.8. Additional items to be considered when locating inlets include:

- A. Low points in gutter grade. Adjust grades to the maximum extent possible to ensure that low point do not occur at driveways, handicap accessible areas, critical access points, etc.
- B. At intersections and ramp entrances and exits to limit the flow of water across roadways.
- C. Upgrade of cross slope rollover at the point fifty (50) feet upstream of the 0% cross slope
- D. Upgrade of all bridges and downgrade of bridges in fill section before the end of curb where the curb is not continuous.
- E. Along mainline and ramps as necessary to limit spread of runoff onto roadway in accordance with Subpart 10.5.5.

10.5.10 Spacing of Inlets

The spacing of inlets along the mainline and ramps is dependent upon the allowable spread and the capacity of the inlet type selected. Maximum distance between inlets is 400 feet. The procedure for spacing of inlets is as follows:

- A. Calculate flow and spread in the gutter. Tributary area is from high point to location of first inlet. This location is selected by the design engineer. Overland areas that flow toward the roadway are included
- B. Place the first inlet at the location where spread approaches the limit listed in Subpart 10.5.9.
- C. Calculate the amount of water intercepted by the inlet, check the grate efficiency. This efficiency should be a minimum of 75%.
- D. The water that bypasses the first inlet should be included in the flow and spread calculation for the next inlet.
- E. This procedure is repeated to the end of the system. Sample calculations are presented in Subsection 10.13.

10.5.11 Depressed Gutter Inlet

Placing the inlet grate below the normal level of the gutter increases the cross-flow towards the opening, thereby increasing the inlet capacity. Also, the downstream transition out of the depression causes backwater which further increases the amount of water captured.

A. Locations of Depressed Inlets

1. All inlets in shoulders greater than 4 feet wide.
2. All inlets in one-lane, low speed ramps.
3. Inlets will not be depressed next to a riding lane, acceleration lane, deceleration lane, two-lane ramps, and direct connection ramps or within the confines of a bridge approach and transition slab.

B. Limits of Depression

1. Begin depression a distance of 4 feet upgrade of inlet.
2. End depression a distance of 2 feet downgrade of inlet.
3. Begin depression 4 feet out from gutter line.
4. Depth of depression, 2 inches below projected gutter grade.

See NJDOT Standard Roadway Construction / Traffic Control / Bridge Construction Details; CD-602-3.3, Method of Depressing Inlets at Shoulders.

C. Spacing of Depressed Inlets

Use the same procedure as described in Subpart 10.5.9. This method will give a conservative distance between inlets; however, this will provide an added safety factor and reduce the number of times that water will flow on the highway riding lanes when the design storm is exceeded.

10.5.12 Snow Melt Control

Roadway safety can be enhanced by snow melt runoff control. Collection of snow melt runoff is important on the high side of superelevated roadways and at low points. A discussion of each situation and the design approach is outlined below.

A. Snowmelt Collection on High Side of Superelevation

Collection of snow melt on the high side of a superelevated section from roadway and berm areas before it crosses the roadway prevents icing during the freeze-thaw process. Therefore, it is desirable to provide a small shoulder sloped back

towards the curb that will provide a means to convey the snow melt water to inlets installed for this purpose. Refer to subsection 5.4.3 for the rate of shoulder cross slope. The snow melt inlets should be placed along the outer curblines at the upstream side of all intersections and at convenient cross drain locations. The snow melt inlets should be connected to the drainage system with a 15 inch diameter pipe to the trunk storm sewer. The small shoulder and snow inlets will not be designed to control stormwater runoff but shall be designed to handle only the small amount of expected flow from the snowmelt.

B. Snowmelt Collection at Low Points

Collection of snowmelt is important at low points where the pile-up of snow over existing inlets prevents draining of snowmelt and runoff off the edge of road. The addition of inlets placed away from the edge of curb and beyond anticipated snow piles provides a means to drain snowmelt.

Snow inlets are required at all roadway profile low points. All snow inlets shall be Type "E". Snow inlets shall not be depressed.

Snow inlets shall be provided in the shoulder immediately adjacent to the travel lane without encroaching on the travel lane.

Snow inlets shall not be installed in shoulders where the width is so narrow that placement of a snow inlet will encroach upon the inlet at the curb.

Pipes draining snow inlets shall be a minimum 15 inches diameter, sloped at a 1% minimum grade wherever possible.

10.5.13 Alternative Runoff Collection Systems

Standard roadway inlets are used to collect runoff on curbed roadways. Compliance with the established spread criteria for roadways with flat grades typically requires many inlets, usually installed at close intervals. Use of alternative collection systems such as trench drains may be appropriate to reduce the number of inlets required to satisfy the spread criteria. Therefore, use of trench drains for runoff collection on roads with flat grades may be warranted. The trench drain should be located upstream of the inlet to which it connects. The length of trench drain should provide the capture capacity that together with the inlet limits bypass at the inlet to zero.

Trench drain capture computations require consideration of both frontal and side flow capture. Frontal flow captured by the narrow trench drain is small and is, therefore, disregarded. Side flow into the trench drain is similar to flow into a curb opening inlet. Hydraulic evaluation procedures for curb opening inlets are described in FHWA HEC-12. Side flow is computed using the procedures for curb opening inlets presented in FHWA HEC-12. The trench drain must be long enough to intercept the bypass after frontal flow plus the additional runoff contributed by the roadway for the length of the trench drain. The process includes the following steps:

- A. Compute the total runoff to the inlet.
- B. Compute the frontal flow captured by inlet with no bypass allowed for the spread limited to the width of the grate. The runoff to be intercepted by the trench drain is the total runoff minus the runoff captured by the inlet.
- C. Compute the length of trench drain required to capture the discharge using the curb opening inlet procedures in FHWA HEC-12. The computed length shall be multiplied by two to reflect inefficiencies due to clogging.

Maintenance requirements for trench drains should also be considered in the

evaluation of trench drains. Use of a trench drain system should be discussed with the Department early in the design process with recommendations submitted prior to completion of the Initial Submission.

10.6 Storm Drains

10.6.1 Introduction

A storm drain is that portion of the roadway drainage system that receives runoff from inlets and conveys the runoff to some point where it can be discharged into a ditch, channel, stream, pond, lake, or pipe. This section contains the criteria and procedures for the design of roadway drainage systems.

10.6.2 Criteria for Storm Drains

Storm drains shall be designed using the following criteria where applicable:

- A. Minimum pipe size is 15 inches.
- B. Minimum pipe size is 18 inches downstream of mainline low points.
- C. Storm sewer pipe materials for proposed systems typically include concrete, aluminum alloy, smooth interior High Density Polyethylene (HDPE) and ductile iron pipe (DIP). Manning's roughness coefficient "n" for concrete and HDPE pipe is 0.012. Manning's roughness coefficients for various materials occasionally encountered are presented in Table 10-8. Manning's roughness coefficient values for aluminum alloy pipe are presented in Table 10-9 (and used for analysis of corrugated metal pipe).

Table 10-8

Manning's Roughness Coefficients for Various Materials

Manning's Roughness Coefficient, "n"		
Closed Culverts:		
	Vitrified clay pipe	0.012-0.014
	Cast-iron pipe, uncoated	0.013
	Steel pipe	0.009-0.011
	Brick	0.014-0.017
Monolithic concrete:		
1.	Wood forms, rough	0.015-0.017
2.	Wood forms, smooth	0.012-0.014
3.	Steel forms	0.012-0.013
Cemented rubble masonry walls:		
1.	Concrete floor and top	0.017-0.022
2.	Natural floor	0.019-0.025
	Laminated treated wood	0.015-0.017
	Vitrified clay liner plates	0.015

Table 10-9
Values of Coefficient of Manning's Roughness (n)
for Corrugated Aluminum Alloy Pipe
(Unpaved Inverts and Unlined Pipe)

Annular 2 2/3" x 1/2" Corrugations	Helical Corrugations*							
All Diameters	1 1/2" x 1/4"			2 2/3" x 1/2"				
	8 inch	10 inch	12 inch	18 inch	24 inch	36 inch	48 inch	60 Inch & Larger
0.024	0.012	0.014	0.011	0.013	0.015	0.018	0.020	0.021
Annular 3" x 1"	Helical - 3" x 1"							
	48 inch	54 inch	60 inch	66 inch	72 inch	78 inch & Larger		
0.027	0.023	0.023	0.024	0.025	0.026	0.027		
Annular 5" x 1"	Helical - 5" x 1"							
	54 inch	60 inch	66 inch	72 inch	78 inch & Larger			
0.025	0.022	0.023	0.024	0.025	0.027			

*The "n" values shown above for helical corrugations apply only when spiral flow can be developed. The design engineer must assure himself/herself that spiral flow will occur in his/her design situation. Spiral flow will not occur when the following conditions exist, in which case the "n" value for annular corrugations is to be used:

1. Partly full flow
2. Non-circular pipes, such as pipe arches
3. When helical pipe is lined or partly lined
4. Short runs less than 20 diameters long

Pipe arches have the same roughness characteristics as their equivalent round pipes

- D. Design to flow full, based on uniform flow.
- E. Minimum self-cleaning velocity of 2.5 ft/sec. should be maintained wherever possible.
- F. Structural design (class or gauge) of storm drains shall be in accordance with current AASHTO Standard Specifications for Highway Bridges. Structural evaluation of storm drains may be made using the following texts/references where appropriate if they are consistent with AASHTO:
 - Concrete: Concrete Pipe Design Manual American Concrete Pipe Association
 - Aluminum Alloy Pipe (as recommended by manufacturer)
 - Smooth interior HDPE (as recommended by manufacturer)
 - Ductile Iron Pipe (DIP) (as recommended by manufacturer). DIP is to be utilized

when minimum cover is unattainable for the alternate materials and where clearances between drainage lines and underground utilities are critical.

- G. Maximum grade on which concrete pipe should be placed is 10%.
- H. HDPE pipe may be used in roadways having less than 20,000 ADT. For other state highways with ADTs exceeding 20,000 vehicles, Interstates and freeways, the use of HDPE is not allowed within the loading influence of the roadway or as outlet pipes to water courses and water bodies; however, in such highways the use of HDPE is permitted outside the loading influence of the roadway. Installation of HDPE pipe shall be according to the manufacturer's specifications. End sections for HDPE pipe shall be concrete. Construction equipment loading and constructability shall be taken into account when considering HDPE for storm drains. A minimum cover of three (3) feet is required. HDPE pipe is not allowed in wet conditions. Wet condition is defined as all areas below the water table (perched or continuous). Seasonal and changing conditions must be evaluated accordingly in determining ground water elevation. HDPE pipe shall not be used as lateral drains and cross drains within the roadway box on evacuation routes and in flood zones.
- I. Flared end-sections should be used whenever and wherever possible, for concrete, HDPE and aluminum pipe.
- J. Pipe sizes should not decrease in the downstream direction even though an increase in slope would allow a smaller size.
- K. Pipe slopes should conform to the original ground slope so far as possible to minimize excavation.
- L. For durability, the minimum gauge thickness for aluminum alloy pipe is 16. In extremely corrosive areas and where high abrasion can be expected the design engineer shall determine whether a heavier gauge should be used.
- M. Alternate Items:
- When the length of the pipe exceeds 500 linear feet, alternate bid items are required.
 - Alternate pipe materials are: concrete, aluminum alloy and HDPE.
 - Some materials may be eliminated as alternate items due to unstable support, high impact, concentrated loading, limited clearance, steep gradients, etc.
- N. The drainage layout should attempt to avoid conflicts with existing underground utilities and such items as utility poles, signal pole foundations, guide rail posts, etc. Implementation of the following design approaches may be necessary.
- Use of pipe material with the lowest friction factor to minimize pipe size
 - Use of elliptical or arch pipe to minimize vertical dimension of pipe.
 - Test pits should be obtained early in the design process to obtain horizontal and vertical information for existing utilities. If the suggested design approaches do not avoid conflict, use of special drainage structures may be used to avoid the utility.

When alternate bid pipe materials are required, separate hydraulic calculations must be developed and submitted for each material considered (concrete, aluminum alloy and HDPE) using the respective roughness coefficients. The reason for exclusive use of a pipe material must be explained in the Drainage Report.

- O. Round corrugated pipe shall have helical corrugations, except that annular corrugated pipe may be used where velocity reduction is desired.
- P. Drainage structures must accommodate all pipe materials used including concrete, aluminum alloy and HDPE.
- Q. Aluminum alloy pipe shall not be used as a section or extension of a steel pipe.
- R. Precast manholes or inlets shall not be used for pipes 54 inches or larger diameter or when three or more pipes tie in and at least two of them are connected at some angles. When these conditions exist, cast-in-place inlets or manholes are more practical.
- S. Cleaning existing drainage pipes and structures shall be incorporated on all projects when the existing drainage system has substantial accumulation of sediments. The cleaning shall extend to the first structure beyond the project limits.
- T. On projects where contaminated areas have been identified, the drainage system should be designed to avoid these locations, if possible. If avoidance is not feasible, a completely watertight conveyance system, including structures such as manholes, inlets, and junction chambers, shall be designed to prevent contaminated groundwater or other pollutants from entering the system. Possible methods to accomplish this include joining pipe sections with a watertight sealant and/or gaskets. Retrofitting existing pipes to make them watertight may require installation of an appropriate internal liner. The design engineer shall provide recommendations prior to proceeding with the final design.
- U. The soffits (overts) between the inflow and outflow pipes at a drainage structure shall be matched where possible. A minimum 1 inch drop between inverts within the structure shall be provided, if feasible.
- V. Existing drainage facilities that are not to be incorporated into the proposed drainage system are to be completely removed if they are in conflict with any element of the proposed construction. Existing drainage facilities that are not to be incorporated into the proposed drainage system that do not conflict with any element of the proposed construction are to be abandoned. Abandonment of existing drainage facilities requires the following:
 - 1. Plugging the ends of the concrete pipes to remain. Metal pipes shall be either removed or filled.
 - 2. Filling abandoned pipes in accordance with geotechnical recommendations.
 - 3. Removing the top of the drainage structure to 1 foot below the bottom of the pavement box, breaking the floor of the structure, and filling the structure with either granular material or concrete in accordance with geotechnical recommendations.
- W. A concrete collar, as shown in the standard detail CD-601-2.3, will be used to join existing to proposed pipe of similar materials unless an approved adapter fitting is available.

10.6.3 Storm Sewer Design

Hydraulic design of the drainage system is performed after the locations of inlets, storm drain layout, and outfall discharge points have been determined. Hydraulic design of the drainage pipe is a two step process. The first step establishes the

preliminary pipe size based on hydrology and simplified hydraulic computations. The second step is the computation of the hydraulic grade line (HGL) for the system. This step refines the preliminary pipe size based on calculation of the hydraulic losses in the system using the hydrology computed in the first step for each section of pipe. The procedures to be performed in step 1 are presented in Subpart 10.6.4, "Preliminary Pipe Size". The procedures to be performed in step 2 are presented in Subpart 10.6.5, "Hydraulic Grade Line Computations".

10.6.4 Preliminary Pipe Size

The preliminary design proceeds from the upstream end of the system toward the outlet at which the system connects to the receiving downstream system. The design runoff for each section of pipe is computed by the Rational formula using the total area that contributes runoff to the system and the Time of Concentration to the upstream end of the pipe. The Time of Concentration increases in the downstream direction of the design and the rainfall intensity consequently decreases. All runoff from the contributing area is assumed to be captured. The inlet capture and by-pass computations used to determine the inlet layout are not used in the hydraulic computation.

The preliminary storm drain size should be computed based on the assumption that the pipe will flow full or practically full for the design runoff. The Manning equation should be used to compute the required pipe size. This preliminary procedure determines the required pipe size based on the friction losses in the pipe. All other losses are disregarded in the preliminary design. In general, the longitudinal grade of the roadway over the pipe being designed should be used as the slope in the hydraulic computation where practical. The HGL computations, as explained in Subpart 10.6.5, consider all losses and establish the actual pipe size required.

Figure 10-F is recommended for use as guidance in performing the preliminary drainage system design. Use of computer programs to perform the computations is encouraged. The computational procedures and output results and presentation format presented in the FHWA Hydrain-Hydra program are recommended for use. Use of other computer programs is acceptable provided, as a minimum, the computational procedures and presentation of output are similar to those presented in Figure 10-F.

The following is an explanation of the Preliminary Storm Drain Computation Form, Figure 10-F. Data is to be presented for each reach of pipe being designed. The numbers refer to each column in Figure 10-F.

1. Station and Offset

Input the location of the upstream and downstream structure for each pipe reach being designed referenced from the base line, survey line, or profile grade line (PGL) shown on the construction documents.

2. Length in feet

Input the distance between the centerline of the upstream and downstream structure.

3. Incremental Drainage Area in acres

Input the drainage area to each structure for each area with a different runoff coefficient that contributes runoff to the upstream structure.

4. Total Drainage Area in acres

Input the cumulative total drainage area. This is a running total of column 3.

5. Runoff Coefficient
Input the rational method runoff coefficient for each area contributing runoff to the structure.
6. Incremental "A" x "C"
Input the incremental drainage area times its runoff coefficient for each area contributing runoff to the structure.
7. Total "A" x "C"
Input the cumulative drainage area times the runoff coefficient. This is a running total of column 6.
8. Flow Time (Time of Concentration) to Inlet in Minutes
Input the overland Time of Concentration to each structure.
9. Flow Time in Pipe in Minutes
Input the flow time in the pipe upstream of the upstream junction (junction from). This time is computed by dividing the pipe length by the actual design flow velocity in the pipe (Column #2 divided by Column #17) for the pipe section upstream of the junction from structure (Column #1). The first pipe length will have no value. The flow time in the pipe will be used to compute the cumulative Time of Concentration (travel time) in the pipe.
10. Cumulative Time in the Pipe in Minutes
Input the cumulative time in the pipe. This is a running total of column 9. If the overland flow to the inlet is greater than the cumulative time in the pipe, then that overland flow time will be added to subsequent flow time in the pipe to determine the longest cumulative Time of Concentration.
11. Rainfall Intensity "I" in inches per Hour
Input the rainfall intensity using Figures 10-A through 10-D and the longest Time of Concentration. The longest Time of Concentration is determined by using the larger of the overland flow time to the inlet (column 8) or the cumulative time in the pipe (column 10).
12. Total Runoff ($Q = CIA$) in cubic feet per Second
Compute the total runoff using the area, runoff coefficient, and rainfall intensity identified in step 11.
13. Pipe Diameter in feet
Compute the required pipe diameter using Manning's equation based on full flow. The tailwater is assumed to be at the elevation of the pipe soffit.
14. Slope in feet per feet
Input the pipe slope used for the pipe design. The slope is typically as close as possible to the roadway longitudinal grade over the pipe reach being designed.
15. Capacity in cubic feet per Second
Compute the pipe capacity using the Manning's equation and full flow conditions.
16. Velocity (full) in feet per Second
Compute the pipe velocity using the full pipe capacity ($V = Q/A$).
17. Velocity (design) in feet per Second

Compute the pipe velocity using the design discharge.

18. Invert Elevation (Upstream End)

Input the pipe invert elevation at the upstream end.

19. Invert Elevation (Downstream End)

Input the pipe invert elevation at the downstream end.

10.6.5 Hydraulic Grade Line computations

The Hydraulic Grade Line (HGL) should be computed to determine the water surface elevation throughout the drainage system for the design condition. The HGL is a line coinciding with either (1) the level of flowing water at any point along an open channel, or (2) the level to which water would rise in a vertical tube connected at any point along a pipe or closed conduit flowing under pressure. The HGL is normally computed at all junctions, such as inlets and manholes. All head losses in the storm drainage system are considered in the computation. The computed HGL for the design runoff must remain at least 1 foot below the top of grate or rim elevation.

Hydraulic control, also commonly referred to as "tailwater", is the water surface elevation from which the HGL calculations are begun. "Tailwater" elevation is established by determining water surface elevation at the locations where the new drainage system will discharge to the receiving waterway, such as a stream, ditch, channel, pond, lake, or an existing or proposed storm sewer system. The tailwater selected for the design should be the water surface elevation in the receiving waterway at the Time of Concentration for the connecting roadway storm sewer being designed or analyzed.

When the system is under pressure and when a higher level of accuracy is required considering storage in the pipe system, pressure flow routing can be performed using computer programs such as the "Pressure Flow Simulation" option in the FHWA Hydrain-Hydra program. Use of a pressure flow routing in the design of a new drainage system or analysis of an existing drainage system should be evaluated early in the initial design. A pressure flow routing is typically appropriate only in special cases, primarily when the available storage attenuates the peak discharge to the extent that downstream pipe sizes are minimized.

Figures 10-G and 10-H are recommended for use as guidance in performing HGL computations. HGL line computations must be provided for all projects. Use of computer software acceptable to the Department to perform the computational procedures is encouraged. The computational procedures, output results, and presentation format similar to what is presented in Figures 10-G and 10-H are required as a minimum.

The following is an explanation of the computation of the Hydraulic Grade Line using Figure 10-G. The computed hydraulic grade line (HGL) for the design runoff must remain at least 1 foot below the roadway finished grade elevation at the drainage structure. Data is to be presented for each reach of pipe being designed. The pipe designation presented in the explanation refers to the pipe being designed unless otherwise noted. The numbers refer to each column in Figure 10-G.

1. Station and Offset

Input the location of the upstream and downstream structure for each pipe reach being designed, referenced from the base line, survey line, or profile grade line (PGL) where applicable from the construction documents.

2. Pipe Diameter (\emptyset) in feet

Input downstream pipe diameter.

3. Flow (Q) in cubic feet per Second

Input flow in downstream pipe (outflow pipe).

4. Pipe velocity in feet per Second

Input the design velocity of the pipe.

5. Hydraulic Radius (R) in feet

Input the hydraulic radius (area divided by wetted perimeter) of the pipe.

6. Length (L) of Pipe in feet

Input the distance between the centerline of the upstream and downstream structure.

7. Manning's "n" Roughness Coefficient

Input the Manning's coefficient "n". Use 0.012 for concrete and smooth interior plastic pipe. The Manning's "n" values for corrugated aluminum alloy pipe are shown in Table 10-9.

8. Velocity Head (h) in feet

Compute the velocity head, $h = V^2/2g$, Where g = acceleration due to gravity.

9. Friction Loss (H_f) in feet

Compute the friction loss in the pipe using the equation:

$$H_f = \frac{29.14n^2}{R^{1.33}} \times \frac{V^2}{2g}$$

**Table 10-10
Entrance Loss Coefficients (K_i)**

This table shows values of the coefficient K_i to apply to the velocity head $V^2/2g$ to determine the loss of head at the entrance of a structure such as a culvert or conduit, operating full or partly full with control at the outlet.

$$\text{Entrance head loss } H_i = K_i V^2/2g$$

Type of Structure and Design of Entrance	Coefficient, K_i
A. Concrete Pipe	
Projecting from fill, socket end (groove-end)	0.2
Projecting from fill, square cut end	0.5
Headwall or headwall and wingwalls	
Socket end of pipe (groove-end)	0.2
Square-edge	0.5
Rounded (radius = $D/12$)	0.2
Mitered to conform to fill slope	0.7
End-section conforming to fill slope *	0.5
Beveled edges, 33.7° or 45° bevels	0.2
Side or slope-tapered inlet	0.2
B. CAAP or CAAPA	
Projecting from fill (no headwalls)	0.9
Headwall or headwall and wingwalls	
Square-edge	0.5
Mitered to conform to fill slope	0.7
End-section conforming to fill slope *	0.5
C. Concrete Box	
Headwall parallel to embankment (no wingwalls)	
Square-edged on 3 edges	0.5
Rounded on 3 edges to radius of 1/12 barrel dimension, Or beveled edges on 3 sides	0.2
Wingwalls at 30 - 75 degrees to barrel	
Square-edged at crown	0.4
Crown edge rounded to radius of 1/12 barrel dimension, Or beveled top edge	0.2
Wingwalls at 10 - 25 degrees to barrel	
Square-edged at crown	0.5
Wingwalls parallel (extension of sides)	
Square-edged at crown	0.7

***NOTE:** "End sections conforming to fill slope", made of either metal or concrete, are the sections commonly available from manufacturers. From limited hydraulic tests they are equivalent in operation to a headwall in both inlet and outlet control.

10. Exit Loss (H_e) in feet

Compute the exit loss of the drainage system using the equation:

$$H_e = V^2/2g, \text{ Where } V = \text{velocity of outflow pipe}$$

The exit loss is computed where the drainage system discharges to a swale, stream, pond, etc. via a headwall or a pipe open end. This loss is calculated for the last downstream pipe segment at the outlet end of the pipe being designed.

11. Entrance Loss (H_i) in feet

Compute the entrance loss of the drainage system using the equation:

$$H_i = K_i V^2 / 2g, \text{ Where } K_i = \text{Entrance Loss Coefficient}$$

The entrance loss is computed at the upstream end of the system where the flow enters the first structure. This is either at a headwall/ end section or the pipe in the beginning upstream inlet. Entrance loss coefficients are presented in Table 10-10.

12. Structural Loss (H_s) in feet

Input the structural loss from Figure 10-H. The structural loss corresponds to the structure at the upstream end of the pipe segment or "junction from".

13. Total Head Loss (H_t) in feet

Compute the total head loss by adding the exit, entrance, friction, and structural loss. The exit and entrance losses are only added at the beginning and end of the pipe system, respectively.

14. Tailwater Elevation (TW) in feet

Input the tailwater elevation at the downstream end of the pipe segment being designed. For the last downstream pipe segment, the tailwater elevation is established by determining the water surface elevation at the location where the pipe discharges to a stream, ditch, channel, pond, lake, or an existing or proposed storm sewer system. The tailwater selected for the design should be the water surface elevation in the receiving waterway at the Time of Concentration for the connecting roadway storm sewer being designed or analyzed. The tailwater elevation for each upstream pipe segment will be the computed headwater elevation (HGL) for the downstream pipe segment.

15. Headwater Elevation (HGL) in feet

Compute the HGL at the upstream end of the pipe segment by adding the total head loss (H_t) to the tailwater elevation (TW) at the downstream end of the pipe.

16. Top of Structure (TOS) Elevation in feet

Input the top of structure elevation which is the top of grate for inlets and rim elevation for manholes.

17. Clearance (CL) in feet

Compute the clearance or difference in elevation between the top of structure (TOS) and the headwater elevation (HGL). The HGL shall be a minimum of 1 foot below the TOS.

The following is an explanation of the computation of structural losses using Figure 10-H. Data is to be presented for each reach of pipe being designed. The numbers refer to each column in Figure 10-H.

1. Station and Offset

Input the location of each drainage structure referenced from the base line, survey line, or profile grade line (PGL) where applicable from the construction documents.

2. Pipe Diameter (\emptyset) in feet

Input downstream pipe diameter (outflow). Equivalent diameter for elliptical or arch pipes may be used.

3. Flow (Q) in cubic feet per second

Input flow in downstream pipe (outflow pipe).

4. Downstream Velocity (v) in feet per second

Input the velocity in the pipe.

5. Velocity Head (h) in feet

Compute the velocity head, $h=V^2/2g$

6. Structure Lateral Configuration

The structural loss coefficient is related to the structure lateral configuration and type of flow. The lateral configuration designation is as follows:

L = Junction with lateral

N = Junction with no lateral

O = Junction with opposed laterals

7. Flow Type

The structural loss coefficient is related to the structure lateral configuration and type of flow. The flow type designation is as follows:

P = Pressure flow

O = Open channel flow

8. Structural Head Loss Coefficient

The structural head loss coefficient is related to the structure lateral configuration and type of flow. Insert the coefficient selected from Table 10-11.

Table 10-11
Structure Head Loss Coefficient (K_s)

Flow Condition	Lateral Configuration	Coefficient
Open Channel	90° Lateral	0.2
Open Channel	No Lateral	0.0
Open Channel	Opposed	0.2
Pressure	90° Lateral	1.0
Pressure	No Lateral	0.3
Pressure	Opposed	1.0

Proper application of the structural loss to the drainage system requires an understanding of which pipe(s) is (are) considered the lateral(s) and which pipes are considered the main. For simplicity, the inflow pipe with the majority of the flow entering the structure is considered the main. All other inflow pipes are considered laterals.

The hydraulic grade line computation for each lateral begins with the water surface elevation for the junction, which includes the structural head loss and bend head loss for the structure. No other losses are associated with the connection of the lateral to the junction.

9. Structural Loss in feet

Compute the structural loss as the product of the structural loss coefficient (column 8) and velocity head (column 5).

10. Angle (A) in degrees

Input the deflection angle between the inflow and outflow main pipes. The angle should be between 0 and 90 degrees.

11. Bend Factor

Insert bend factor from Figure 10-I.

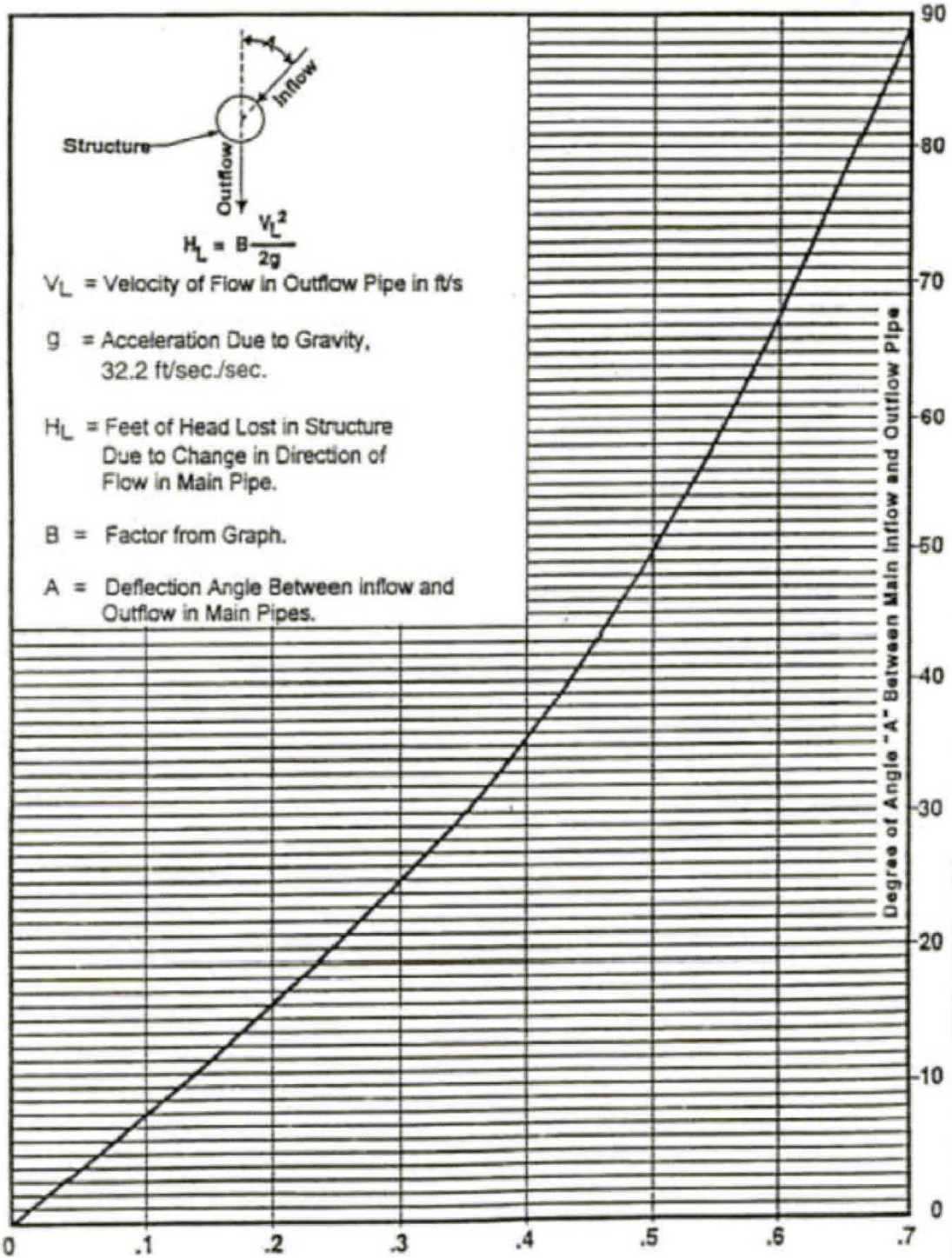
12. Bend Loss in feet

Compute the bend loss as the product of the bend factor (column 11) and velocity head (column 5).

13. Structural Loss + Bend Loss in feet

Compute the sum of the structural loss (column 9) and the bend loss (column 12).

**FIGURE 10-I:
BEND LOSS FACTOR**



REV. DATE: JUNE 30, 2015

10.7 Median Drainage

10.7.1 Introduction

The basic purpose of a median is to separate opposing lanes of traffic. The widths, grade and shape of a median is determined for the most part by safety considerations. A wide, shallow, depressed median is usually selected as best fulfilling the median purpose.

A provision to drain the median by means of inlets must be included in the median design. Median inlets shall be provided to limit the depth of flow to 6 inches to confine the spread to the median and below the pavement subgrade. This section contains procedures and criteria for the design of median drainage.

10.7.2 Median Inlet Type

All median inlets are to be Type "E".

10.7.3 Median Design Criteria - Continuous Grade

Median inlets should intercept the total design flow from its discharge area plus any by-pass from upstream. The drainage area to each inlet must be adjusted by inlet spacing to limit the design flow to a maximum depth of 6 inches. Because of the variable parameters in the spread calculations, each inlet must be investigated.

The recurrence interval used in the design is the same as that of the longitudinal roadway system.

10.7.4 Procedure for Spacing Median Drains

Channel capacity shall be computed using the procedures presented in Subsection 10.4, Channel Design.

Inlet capture for inlets on grade shall be computed using the weir equation stated as follows:

$$Q_i = C_w P y^{1.5}$$

where

Q_i = flow rate intercepted by the grate ft³/s

C_w = weir coefficient

P = weir length (ft)

y = depth (ft) for the approach flow

The weir flow coefficient is 3.0. The weir length to be used is the frontal flow length of the inlet.

Inlet capture for inlets at low points shall be computed using the procedures in Subpart 10.5.8 "Capacity of Grate Inlets at Low Points".

Judgment should be used in a cut section to place these inlets economically as well as functionally. Some leeway is afforded the design engineer to place the median inlets opposite roadway edge inlets. This simplifies connections and reduces pipe lengths. The water that bypasses the inlet because of the above, should be added to the next inlet's design runoff.

10.8 Culvert Design

10.8.1 Introduction

A highway embankment constitutes a barrier to the flow of water where the highway crosses water courses. A culvert is a closed conduit that provides a means of carrying the flow of water through the embankment.

10.8.2 Culvert Types

- A. Pipes: Aluminum and reinforced concrete pipe culverts are shop manufactured products available in a range of sizes in the standard shapes. Aluminum pipes are available in round and arch shapes. Aluminum pipes are available in round and arch shapes. Reinforced Concrete pipes are available in round and elliptical shapes. Round shapes are generally more economical, due to their greater strength.

Pipe flow characteristics for different pipes change due to their relative roughness.

Additional capacity can be obtained with multiple pipe installations. Multiple installations are accomplished by installing several individual culvert pipes parallel to each other with enough separation to allow for proper compaction.

- B. Reinforced Concrete Boxes (RCB's): Box culverts are either precast off-site or constructed in the field by forming and pouring. Box culverts may be constructed to any desired size in either square or rectangular shapes. These designs may be easily altered to allow for site conditions. The flow characteristics of RCB's are very good as their barrels provide smooth flow and their inlet may be designed for extra efficiency where needed.

Where a multiple culvert installation is indicated, the RCB may be constructed with two or more barrels. NJDEP Flood Hazard Area Permit requirements may dictate when multiple culverts can be used. The minimum width, if possible, will be 10 feet per box. For streams with a drainage area greater than 50 acres, the NJDEP Flood Hazard Area Permit requirements will also dictate the need to provide a fish passage in at least one box culvert. Guidance regarding fish passage provisions in culverts are presented in Subpart 10.8.8.

10.8.3 Culvert Location

The alignment of a culvert in both plan and profile should ensure efficient hydraulic performance, as well as keep the potential for erosion and sedimentation to a minimum. The criteria given in Subsection 10.4, "Channel Design", should be considered in the location of the culvert. Usually, the ideal location for the culvert is the existing channel, with the slope the same as the existing channel.

10.8.4 Culvert Selection

Select a culvert type and size that is compatible with hydraulic performance, structural integrity,, economics, and environmental and permitting considerations. The structural requirements for various pipes may be found in references (1), (2), and (3).

10.8.5 Culvert Hydraulics

Laboratory tests and field observations show two major types of culvert flow: flow with inlet control and flow with outlet control. Different factors and formulas are used to compute the hydraulic capacity of a culvert for each type of control. Under inlet control, the cross-sectional area of the culvert barrel, the inlet geometry and

the amount of headwater or ponding at the entrance are of primary importance. Outlet control involves the additional consideration of the elevation of the tailwater in the outlet channel and the slope, roughness and length of the culvert barrel. It is possible by involved hydraulic computations to determine the probable type of flow under which a culvert will operate for a given set of conditions. The need for making these computations may be avoided, however, by computing headwater depths from available charts and/or computer programs for both inlet control and outlet control and then using the higher value to indicate the type of control and to determine the headwater depth. This method of determining the type of control is accurate except for a few cases where the headwater is approximately the same for both types of control. Refer to FHWA HDS-5 - Hydraulic Design of Highway Culverts for detailed culvert design procedures.

10.8.6 Culvert End Structures

Culvert end structures may be used for the following purposes:

- To improve the hydraulic efficiency of the culvert.
- To provide erosion protection and prevent flotation.
- To retain the fill adjacent to the culvert.

These structures include headwalls, concrete flared end sections and improved inlet structures to increase capacity. Each type is described in the following narrative.

- A. **Headwall:** A headwall is a retaining wall attached to the end of a culvert. (see current Standard Construction Details CD-602-10). The alignment of the headwall should be normal to the centerline of the barrel to direct the flow into the barrel. The wingwalls should be long enough to prevent spillage of the embankment into the channel. A cutoff wall attached to the downstream end of the unit if a concrete apron is not provided at the headwall. The cutoff wall may be a concrete unit across the entire width of the downstream end of the flared end section. The cutoff wall shall be a minimum of 1.5 feet thick and 3.0 feet deep (see current Standard Construction Details).
- B. **Concrete Flared End Sections:** A concrete flared end section is a precast unit with a beveled and flared end that provides an apron at the outlet end of the pipe. The bevel approximately conforms to embankment slope. Limited grading of the embankment is usually required around the end of the flared end section. Installation of a flared end section requires installation of a cutoff wall attached to the downstream end of the unit. The cutoff wall may be a concrete unit across the entire width of the downstream end of the flared end section. The cutoff wall shall be a minimum of 1.5 feet thick and 3.0 feet deep (see current Standard Construction Details).
- C. **Improved Inlet:** An improved culvert inlet incorporates inlet geometry refinements to increase the capacity of a culvert operating with inlet control. These geometry improvements include beveled edges, side tapers and slope tapers functioning either individually or in combination.

10.8.7 Flood Routing at Culverts

The presence of substantial storage volume below the allowable headwater elevation at the upstream end of a culvert warrants evaluation of the resultant peak flow attenuation. The reduced peak discharge resulting from attenuation yields a reduced culvert size for a new crossing. Attenuation of the peak discharge at existing crossings may indicate that the existing culvert is adequate or may reduce the size of the relief or replacement culvert. For this reason, flood routing

computations shall be performed for all culvert locations except where the proposed topography indicates that limited storage volume, such as is typical with deep incised channels, is available.

Flood routing evaluation at a culvert provides a realistic indication of hydrologic conditions at the culvert entrance. A more realistic assessment can be made where environmental concerns are important. The extent and duration of temporary upstream ponding determined by the flood routing computations can help improve the environmental assessment of the proposed construction.

The design procedure for flood routing through a culvert is the same as for reservoir routing. Additional information on flood routing and storage is included in Subpart 10.3.6.

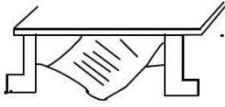

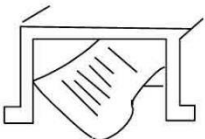
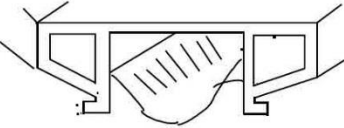
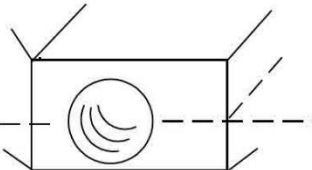
10.8.8 Aquatic Species (Including Fish) Passage

Aquatic species/fish passage is historically a concern with culverts. Failure to consider aquatic species/fish passage may block or impede upstream aquatic species/fish movements in the following ways:

- inlet and outlet of the culvert are installed above the streambed elevation to where aquatic species/fish may not be able to enter.
- scour lowers the streambed downstream of the culvert outfall and the resulting dropoff creates a potential vertical barrier.
- high outlet velocity may provide a barrier.
- higher uniform velocities within the culvert than occur in the natural channel may prevent aquatic species/fish from entering or transiting the culvert.
- abrupt drawdown, turbulence, and accelerated flow at the inlet to the culvert entrance may prevent aquatic species/fish from exiting the culvert.
- natural channel replaced by an artificial channel may have no zones of quiescent water in which aquatic species/fish can rest.
- debris barriers (including ice) upstream or within the culvert may stop aquatic species/fish movement.
- shallow depths within the culvert during minimum flow periods may preclude aquatic species/fish passage.

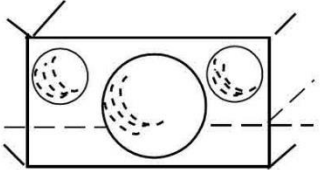
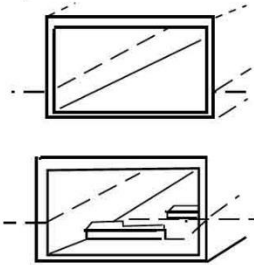
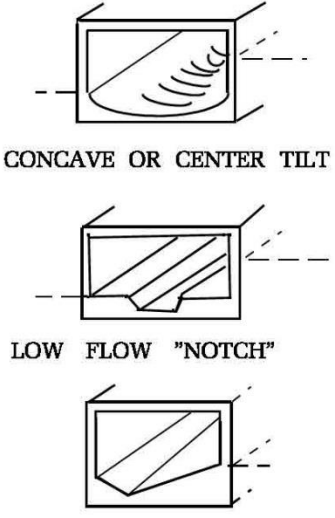
The design engineer is encouraged to refer to the NJDEP Technical Manual, Flood Hazard Area Control Act Rules, in addition to Figures 10J-1 and 10J-2 for the latest acceptable methods for providing aquatic species/fish passage in all proposed box culvert installations. For more guidance on aquatic species/fish passage provisions in proposed culvert installations, contact the NJDEP Division of Fish and Wildlife.

**FIGURE 10-J1:
LOW FLOW AQUATIC PASSAGE FOR
BRIDGES AND CULVERTS**

ORDER OF PREFERENCE	Class A > 5 ft NJAC 7:13-11.7(f)	Class A < 5 ft NJAC 7:13-11.7(g)	Class C NJAC 7:13-11.7(h)
<p align="center"> SPANNING  BRIDGE  ARCH CULVERT  3- SIDED CULVERT </p> <p align="left">NJAC 7:13-11.7 (i)</p>	<p align="center">ACCEPTABLE</p> <p>Must utilize spanning of the stream. The stream bottom must remain intact. Span must be adequately sized such that there is no increase in velocity. There should be no need to hand armoring of the stream.</p>	<p align="center">ACCEPTABLE</p> <p>Must utilize spanning of the stream. The stream bottom must remain intact. Span must be adequately sized such that there is no increase in velocity. There should be no need to hand armoring of the stream.</p>	<p align="center">ACCEPTABLE</p> <p>Must utilize spanning of the stream. The stream bottom must remain intact. Span must be adequately sized such that there is no increase in velocity. There should be no need to hand armoring of the stream.</p>
<p align="center">  SPANNING WITH SIDE-RELIEF CULVERTS </p> <p align="left">NJAC 7:13-11.7 (j)</p>	<p align="center">WAIVER</p> <p>Under N.J.A.C. 7:13-11.7(m) required to construct</p>	<p align="center">ACCEPTABLE</p> <p>Span a stream at bank full flow (15 to 2 year storm); one or more side relief culverts are placed to carry additional storm flood flows. Twin or multicell culverts should have the flow treatment in only one of the culverts.</p>	<p align="center">ACCEPTABLE</p> <p>Span a stream at bank full flow (15 to 2 year storm); one or more side relief culverts are placed to carry additional storm flood flows. Twin or multicell culverts should have the flow treatment in only one of the culverts.</p>
<p align="center">  OVERSIZE / BELOW GRADE </p> <p align="left">NJAC 7:13-11.7 (k)</p>	<p align="center">WAIVER</p> <p>Under N.J.A.C. 7:13-11.7(m) required to construct</p>	<p align="center">WAIVER</p> <p>Under N.J.A.C. 7:13-11.7(m) required to construct</p>	<p align="center">ACCEPTABLE</p> <p>Natural substrate must be placed in the culvert to form a flow channel or a pool area. Minimum 2 feet deep. Must check for the stability of the backfill material.</p>

REV. DATE: JUNE 30, 2015

**FIGURE 10-J2:
LOW FLOW AQUATIC PASSAGE FOR
BRIDGES AND CULVERTS**

ORDER OF PREFERENCE	Class A > 5 ft NJAC 7:13-11.7(f)	Class B < 5 ft NJAC 7:13-11.7(g)	Class C NJAC 7:13-11.7(h)
<p align="center">NJAC 7:13-11.7 (k)</p>  <p align="center">BANKFULL CROSSING WITH RELIEF</p>	<p align="center">WAIVER</p> <p>Under N.J.A.C. 7:13-11.7(m) required to construct</p>	<p align="center">WAIVER</p> <p>Under N.J.A.C. 7:13-11.7(m) required to construct</p>	<p align="center">ACCEPTABLE</p> <p>Span a stream at bank full flow (15 to 2 year storm); one or more side relief culverts are placed to carry additional storm flood flows. Twin or multicell culverts should have the flow treatment in only one of the culverts.</p>
<p align="center">NJAC 7:13-11.7 (l)</p>  <p align="center">OVERSIZED / BELLOW GRADE</p>	<p align="center">WAIVER</p> <p>Under N.J.A.C. 7:13-11.7(m) required to construct</p>	<p align="center">WAIVER</p> <p>Under N.J.A.C. 7:13-11.7(m) required to construct</p>	<p align="center">ACCEPTABLE</p> <p>If the Velocity of the stream is high, then the culvert may require baffles or weir plates to hold the substrate in place. In addition, native rock or cobble may be mixed with the soil to form more stable substrate inside the culvert.</p>
<p align="center">NJAC 7:13-11.7 (l)</p>  <p align="center">CONCAVE OR CENTER TILT</p> <p align="center">LOW FLOW "NOTCH"</p> <p align="center">TILTED</p>	<p align="center">WAIVER</p> <p>Under N.J.A.C. 7:13-11.7(m) required to construct</p>	<p align="center">WAIVER</p> <p>Under N.J.A.C. 7:13-11.7(m) required to construct</p>	<p align="center">ACCEPTABLE</p> <p>Degraded streams, poor ecological value, concrete bottoms, rip rap/gabion bottom, no aquatic and wildlife resources.</p>

REV. DATE: JUNE 30, 2015

10.9 Conduit Outlet Protection

The purpose of conduit outlet protection is to provide a stable section of area in which the exit velocity from the pipe is reduced to a velocity consistent with the stable condition downstream. The need for conduit outlet protection shall be evaluated at any location where drainage discharges to the ground surface or a channel, ditch or stream. This may occur at the downstream end of culverts or other drainage systems.

The need for conduit outlet protection shall be determined by comparing the allowable velocity for the soil onto which the pipe discharges to the velocity exiting the pipe. The allowable velocity for the soil shall be that given in the NJDOT Soil Erosion and Sediment Control Standards Manual. The velocity in the pipe shall be that which occurs during passage of the design storm or of the 25-year storm, whichever is greater. When the velocity in the pipe exceeds the allowable velocity for the soil, outlet protection will be required.

For a detail of conduit outlet protection for a flared end section or headwall, see the Standard Roadway Construction Detail CD-601-2, "Stormwater Outfall Protection".

10.9.1 Riprap Size and Apron Dimensions

Conduit outlet protection and apron dimensions shall be designed in accordance with procedures in the NJDOT Soil Erosion and Sediment Control Standards Manual. The minimum d_{50} stone size shall be 6 inches. A tail water depth equal to $0.2 D_o$ shall be used where there is no defined downstream channel or where T_w cannot be computed.

10.9.2 Energy Dissipators

Energy dissipators are typically required when the outlet velocity is 15 ft/s or greater. Energy dissipators shall be provided when the stable velocity of the existing channel is exceeded, or when design of standard riprap conduit outlet or channel protection results in an impractical stone size and/or thickness. Energy dissipators for channel flow have been investigated in the laboratory, and many have been constructed, especially in irrigation channels. Designs for highway use have been developed and constructed at culvert outlets. All energy dissipators add to the cost of a culvert; therefore, they should be used only to prevent or to correct a serious erosion problem that cannot be corrected by normal design of standard soil erosion and sediment control elements.

The judgment of engineers is required to determine the need for energy dissipators at culvert outlets. As an aid in evaluating this need, culvert outlet velocities should be computed. These computed velocities can be compared with outlet velocities of alternate culvert designs, existing culverts in the area, or the natural stream velocities. In many streams the maximum velocity in the main channel is considerably higher than the mean velocity for the whole channel cross section. Culvert outlet velocities should be compared with maximum stream velocities in determining the need for channel protection. A change in size of culvert does not change outlet velocities appreciably in most cases.

Outlet velocities for culverts flowing with inlet control may be approximated by computing the mean velocity for the culvert cross section using Manning's equation.

Since the depth of flow is not known, the use of tables or charts is recommended in solving this equation. The outlet velocity as computed by this method will usually be high because the normal depth, assumed in using Manning's equation, is seldom reached in the relatively short length of the average culvert. Also, the shape of the

outlet channel, including aprons and wingwalls, has much to do with changing the velocity occurring at the end of the culvert barrel. Tailwater is not considered effective in reducing outlet velocities for most inlet control conditions.

In outlet control, the average outlet velocity will be the discharge divided by the cross-sectional area of flow at the outlets. This flow area can be either that corresponding to critical depth, tailwater depth (if below the top of the culvert) or the full cross section of the culvert barrel.

Additional design information for energy dissipators is included in FHWA HEC-14, Hydraulic Design of Energy Dissipators for Culverts and Channels.

10.10 Reset Castings - Manholes and Inlets

10.10.1 Reset Castings and Construction Practices

Where a manhole or inlet is to be raised using the item, Reset Castings and the existing hardware is excessively worn or in otherwise poor condition, a new frame and cover or grate shall be used.

The condition of the existing hardware and its probable performance after resetting needs to be assessed. If wear has caused the cover to be depressed more than 1/4 inch below the top of the frame, a new frame and cover or grate shall be specified.

On new pavement elevations exceeding 3 1/2 inches, castings shall be reset as follows: on multi-course resurfacing projects, the base and/or binder course shall be placed before a manhole frame is raised. This increases the accuracy in bringing the manhole to the proper grade and cross slope and leaves no more than 1 1/2 inches of casting exposed to traffic, thus permitting the roadway to be opened to traffic. If the specified cross slope of the overlay is different from that of the existing pavement, an extension ring with the necessary slope change built into the casting shall be specified.

For purposes of plan preparation, Cast Iron Extension Frames for Inlets and Extension Rings for Manholes shall be used to raise existing castings a maximum of 3 1/2 inches. When existing castings are required to be raised more than 3 1/2 inches to a maximum of 12 inches, the item Reset Castings shall be used. The item Reset Castings shall also be used to lower grades and elevations up to 12 inches. Adjustments of grades and elevations in excess of 12 inches will be considered as reconstructing inlets and manholes and the appropriate pay items shall be used.

Before Cast Iron Extension Frames or Rings are called for at a particular location, a determination shall be made by the design engineer as to whether the existing casting was previously raised using a Cast Iron Extension Frame or Ring, and what height was used. If a Cast Iron Extension Frame or Ring was previously used and the sum of the previous resetting plus the proposed resetting exceeds 3 1/2 inches, then the item Reset Castings or the appropriate reconstruction item shall be used.

10.10.2 Extension Rings and Frames

When structures contain existing frames or rings, these extension frames or rings shall be removed. Multiple extension frames and rings are not allowed.

The design engineer may decide to reset a particular head by either using the item, Reset Castings, or by installing an extension frame. This decision will primarily be influenced by the following factors:

- A. The height to which the head is to be raised.

- B. The maximum height of the casting above the roadway surface when open to traffic.
- C. The prevailing traffic speed and volume.
- D. The location of the casting in the traveled way or shoulder.
- E. Expected interference with traffic flow.
- F. The actual condition of the casting.
- G. The comparative costs of resetting a casting (e.g. in concrete pavement, resetting is generally more expensive).

While some case-by-case analyses of these factors will be required, if the rise of head is between 1 1/2 inches to 3 1/2 inches, an extension unit will generally be specified. If the rise of the elevation is less than 1 1/2 inches or more than 3 1/2 inches, the casting will be reset by the conventional method.

10.10.3 Extension Rings - Manholes

On all resurfacing projects where the proposed overlay thickness is between 1 1/2 inches and 3 1/2 inches, an extension ring shall be used to reset heads.

When installing the extension ring, any rise above 1 1/2 inches must be paved over and reset before the surface course is placed unless the binder course is placed before opening the roadway to traffic.

The minimum thickness for a manhole extension ring is 1 1/2 inches. Since the Standard Manhole Cover is 2 inches thick, any height adjustments in the range of 1 1/2 inches and 2 1/4 inches will require a new Heavy Duty Cover (1 inch thick). Any salvageable cover in good condition can only be used in an extension ring 2 1/2 inch or more in height.

The following guidelines shall assist in determining where to use Extension Rings for Existing Manholes:

- A. If the rise, R, is from 1 1/2 inches to less than 2 1/2 inches, an Extension Ring for Heavy Duty Cover (1 inch thick cover) is warranted.
- B. If R is 2 1/2 inches to 3 1/2 inches, use a new Extension Ring for Standard Cover (2 inches thick cover).
- C. If R is less than 1 1/2 inches or greater than 3 1/2 inches, use the item Reset Castings, to raise the manhole.

10.10.4 Extension Frames - Inlets

The minimum height of an inlet extension frame is 1 3/4 inches. Depending on how extensively depressed or "dished" an existing inlet may be, an extension of 2 inches, 2 1/2 inches, or 3 inches high may be required to enable the top elevation of the head to be set flush with the finished grade of a 1 1/2 inches overlay.

The following guidelines shall assist in determining where to use Extension Frames for Existing Inlets:

- A. If R is 1 3/4 inches to 3 1/2 inches, inclusive, use an extension frame.
- B. If R is less than 1 3/4 inches or greater than 3 1/2 inches, the manhole is to be raised using the item, Reset Castings.
- C. In general, inlets use a standard 1 1/4 inches grate on all extension frames.

10.10.5 Ramping

Ramping around the reset heads prior to final paving shall be accomplished as follows:

- A. On single course (1 1/2 inches and variable) projects, a circular ramp of hot mix shall be placed about the periphery of the manhole to extend 3 feet laterally and shall leave 1/2 inch of the extension ring exposed; this should avoid the occurrence of under-compacted, shoddy-appearing areas (due to feathering) when the surface course is placed.
- B. For multi-course resurfacing projects, the base and/or binder course should be placed before the casting is reset. This increases the accuracy of raising the casting to be flush with the finished pavement and enables the work progress to be in greater conformity with the policy of not having more than 1 1/2 inches exposed for more than 48 hours.
- C. For a 3 inch resurfacing where 1 1/2 inches is to be milled off, after milling, the bituminous ramp will be placed as for the single course in "A". The binder course will then be placed so that the casting will end up being set flush with the finished pavement grade.
- D. For the occasional 2 inch overlays, ramps will be constructed as for the 1 1/2 inches course.
- E. Do not reset the casting until the topmost (if more than one) bottom course has been placed so that not more than 1 1/2 inches will be exposed for more than 48 hours before bringing the pavement to grade.
- F. The brickwork shall be set with a high early strength, non-shrink mortar developing a one-hour compressive strength of 2500 PSI at 70°F. The mortar should not contain any gypsum, iron particles or chlorides.

10.11 Stormwater Management

10.11.1 Introduction

As previously stated in Subsections 10.1 and 10.2, stormwater management is an important consideration in the design of roadway drainage systems. Stormwater management practices, when properly selected, designed, and implemented, can be utilized to mitigate the adverse hydrologic and hydraulic impacts caused by NJDOT facilities and mitigate the loss in groundwater, thereby protecting the health of streams and wetlands, and the yield of water supply wells, and downstream areas from increased flooding, erosion, and water quality degradation. Stormwater management is required if the proposed roadway project disturbs one (1) or more acres of land or creates at least 0.25 acre of new or additional impervious surface.

This section will focus on design elements of structural stormwater management facilities common to proposed roadway projects, or retrofits to existing roadways, which typically include detention basins, infiltration basins, or a combination thereof. Detention basins may be either wet or dry ponds.

Additional guidance regarding the design of stormwater management facilities is presented in the Stormwater Best Management Practices Manual. All designs must comply with the appropriate regulatory requirements and the Stormwater Best Management Practices Manual.

A. Stormwater Quantity Requirements

As per the New Jersey Stormwater Management Rules at N.J.A.C. 7.8-5.4(a)3, Stormwater BMPs shall be designed to one of the following:

1. The post-construction hydrograph for the 2-year, 10-year, and 100-year storm events do not exceed, at any point in time, the pre-construction runoff hydrographs for the same storm events.
2. There shall be no increase, as compared to the pre-construction condition, in peak runoff rates of stormwater leaving the project site for the 2-year, 10-year, and 100-year storm events and that the increased volume or change in timing of stormwater runoff will not increase flood damage at or downstream of the site. This analysis shall include the analysis of impacts of existing land uses and projected land uses assuming full development under existing zoning and land use ordinances in the drainage area.
3. The post-construction peak runoff rates for the 2-year, 10-year, and 100-year storm events are 50%, 75%, and 80%, respectively, of the pre-construction rates. The percentages apply only to the post-construction stormwater runoff that is attributed to the portion of the site on which the proposed development or project is to be constructed.
4. In tidal flood hazard areas, stormwater runoff quantity analysis shall only be applied if the increased volume of stormwater runoff could increase flood damages below the point of discharge.

B. Groundwater Recharge Requirements

As per the NJDEP Stormwater Rules at N.J.A.C. 7.8-5.4(a)2, stormwater BMPs must be designed to perform to the following:

- The stormwater BMPs maintain 100% of the average annual preconstruction groundwater recharge volume for the site; or
- The increase in stormwater runoff volume from pre-construction to post-construction for the 2-year storm is infiltrated. NJDEP has provided an Excel Spreadsheet to determine the project sites annual groundwater recharge amounts in both pre- and post-development site conditions. A full explanation of the spreadsheet and its use can be found in Chapter 6 of the New Jersey Stormwater Best Management Practices Manual. A copy of the spreadsheet can be downloaded from <http://www.njstormwater.org>.

10.11.2 Methodology

As previously stated in Subsections 10.1 and 10.2, specific stormwater management requirements to control the rate and/or volume of runoff may be dictated by various regulatory agencies. Groundwater recharge is required by the Stormwater Management Rule. Peak runoff discharge rates may also be limited by capacity constraints of existing downstream drainage systems.

The tasks that typically need to be performed in the design of stormwater management facilities for stormwater quantity and groundwater recharge are summarized as follows:

A. Detention Basin

- calculate inflow hydrographs;
- calculate maximum allowable peak outflow rates;
- calculate stage vs. storage data for the basin;

- calculate stage vs. discharge curve for the outlet; and
- perform flood routing calculations.

B. Infiltration Basin

- Same as for detention basin except that the stage vs. discharge curve is based on the infiltration rate; and
- The basin must be designed so that the design runoff volume is completely infiltrated within 72 hours of the end of the storm.

C. Detention/Infiltration Basin

Same as detention basin with the following modifications:

- The infiltration rate is typically very small relative to the discharges from the outlet structure, and is, therefore, disregarded in the stage vs. discharge curve; and
- The basin must be designed so that the volume to be infiltrated is completely infiltrated within 72 hours of the end of the storm.

Inflow hydrographs shall be computed using either the Modified Rational Method or the SCS 24-hour storm methodology as described in Subpart 10.3.6, depending upon the contributory drainage area. The Modified Rational Method is described in detail in Appendix A-9 of the NJDOT's Soil Erosion and Sediment Control Standards.

The allowable peak outflow rates shall be determined as follows:

- For regulated stormwater management facilities, i.e. requiring regulatory agency review, maximum allowable outflow rates shall be as dictated by said regulatory agency.
- For non-regulated stormwater management facilities, i.e. NOT requiring regulatory agency review, the allowable outflow rate shall avoid an unreasonable increase in runoff resulting from the project. The peak outflow rate shall be determined for the roadway design storm and the storms with a recurrence interval of once in 2-, 10-, and 25-years. Downstream stability shall be evaluated for any proposed peak outflow rate that results in an unreasonable increase in the existing peak flow rate and appropriate action shall be taken to avoid unreasonable erosion or flooding resulting from the proposed construction.

Storage volume and outlet structure rating curve data are site specific and will vary for each pond; however, sufficient storage volume shall be provided and the outlet structures shall be configured so that outflow requirements are as described in Subpart 10.11.2 are satisfied.

Flood routing calculations shall be based upon the Storage Indication Method (Modified Puls). As stated in Subsection 10.3.6, the use of computer software programs such as Pond-2, HEC-1, and/or TR-20 to perform these iterative routing calculations is encouraged. Any one of these procedures is acceptable.

A typical method to maintain the existing groundwater recharge is to provide a retention/extended detention basin or sand and vegetative filter strips. An analysis of the pre- and post- developed on-site groundwater recharge conditions can be determined by using the NJDEP's New Jersey Groundwater Recharge Spreadsheet found in the New Jersey Best Management Practices Manual. For Groundwater Recharge, it is important that the permeability rate be tested at the location of the BMP. The BMP must have a minimum Permeability of 0.2 to 0.5 inches per hour and

the BMP structure must drain in less than 72 hours. For more guidance on the design of Groundwater Recharge BMPs, see Chapter 6, of the New Jersey Stormwater Best Management Practices Manual. Chapter 6 also has guidance on the use of the Groundwater Recharge Spreadsheet Program. A copy of the Spreadsheet is located in Figures 10-K and 10-L. The Spreadsheet can be downloaded from <http://www.njstormwater.org>.

10.11.3 Stormwater Management Facility Locations

The location of stormwater management facilities will depend on several factors such as location of receiving water course, location of roadway profile low points, groundwater elevations, environmental and permitting consideration, etc.

The design engineer should first consider, and make maximum use of locations within NJDOT right-of-way, e.g. at interchanges, ramp infield areas, wide medians, before locating facilities which require additional right-of-way. However, site/project specific constraints will ultimately dictate exact locations of stormwater management facilities.

10.11.4 Stormwater Management Facility Design Features

Detention ponds may be excavated depressions (cut) or diked (dammed) by means of an embankment. It should be noted that any embankment/pond that raises the water level more than 5 feet above the usual mean, low water height, or existing ground, when measured from the downstream toe-of-dam to the spillway crest on a permanent or temporary basis must conform to NJAC 7:20 "Dam Safety Standards", effective March 3, 2011.

Detention ponds shall incorporate the following design features:

- A. Pond side slopes shall be 1 (vertical) on 3 (horizontal) or flatter to facilitate mowing.
- B. A low flow channel shall be provided having a minimum slope of 0.5% and side slopes of 1 on 3 or flatter.
- C. The pond bottom shall be graded to drain to the low flow channel at a minimum slope of 1.0%.
- D. A ten (10) foot wide flat safety bench shall be provided 1 foot above the normal pool elevation in a wet pond.
- E. All ponds shall be evaluated for fencing needs. The evaluation shall be submitted to the Bureau of Landscape Design and Scoping and Review for their review.
- F. To the maximum extent practicable, outlet structures shall be designed so as to require minimal maintenance. Trash racks and safety grating shall be provided.
- G. Dry detention ponds and the portion of a wet pond above the normal pool elevation shall be topsoiled and seeded. The Landscape and Urban Design Unit should be contacted for guidance regarding seeding requirements and additional landscaping features in and around proposed ponds.
- H. The height and fluctuation of the groundwater table shall be taken into account when designing any wet or dry pond. Design of a dry pond with a bottom elevation below the seasonal high water table may result in periodic flooding of the pond.

In addition, an access ramp to the stormwater management facility may be provided to allow NJDOT maintenance personnel and equipment to enter the facility for maintenance/cleaning operations. Where an access ramp into stormwater management facilities for truck access to basin bottom and outlet structure for maintenance is required, the following criteria should be applied:

- Width: 13 feet wide; and
- 8% slope desirable, 12% maximum.

Refer to the NJDEP Stormwater Best Management Practices Manual for recommended outlet structure designs and more detailed design data for stormwater management facilities.

FIGURE 10-K

New Jersey
Groundwater
Recharge
Spreadsheet
Version 2.0
November 2003

Annual Groundwater Recharge Analysis (based on GSR-32)

Select Township ↓	Average Annual P (in)	Climatic Factor
MIDDLESEX CO., PERTH AMBOY CITY	47.8	1.53

Project Name:	Sample Project
Description:	This is a test application
Analysis Date:	09/01/03

Pre-Developed Conditions					
Land Segment	Area (acres)	TR-55 Land Cover	Soil	Annual Recharge (in)	Annual Recharge (cu.ft)
1	1.4	Open space	Woodstown	12.9	65,498
2	0.3	Gravel, dirt	Woodstown	6.9	7,536
3	3.5	Woods-grass combination	Woodstown	13.5	171,255
4	1.4	Open space	Keyport	13.4	68,146
5	0.5	Gravel, dirt	Keyport	7.5	13,657
6	3.3	Woods-grass combination	Keyport	13.9	165,963
7	0				
8	0				
9	0				
10	0				
11	0				
12	0				
13	0				
14	0				
15	0				
Total =	10.4			Total Annual Recharge (in)	Total Annual Recharge (cu-ft)
				13.0	492,054

Post-Developed Conditions					
Land Segment	Area (acres)	TR-55 Land Cover	Soil	Annual Recharge (in)	Annual Recharge (cu.ft)
1	1.5	Impervious areas	Keyport	0.0	-
2	1.6	Gravel, dirt	Woodstown	6.9	40,191
3	3.65	Open space	Keyport	13.4	177,667
4	3.65	Open space	Woodstown	12.9	170,762
5	0				
6	0				
7	0				
8	0				
9	0				
10	0				
11	0				
12	0				
13	0				
14	0				
15	0				
Total =	10.4			Total Annual Recharge (in)	Total Annual Recharge (cu.ft)
				10.3	388,620

Procedure to fill the Pre-Development and Post-Development Conditions Tables

For each land segment, first enter the area, then select TR-55 Land Cover, then select Soil. Start from the top of the table and proceed downward. Don't leave blank rows (with A=0) in between your segment entries. Rows with A=0 will not be displayed or used in calculations. For impervious areas outside of standard lots select "Impervious Areas" as the Land Cover. Soil type for impervious areas are only required if an infiltration facility will be built within these areas.

Annual Recharge Requirements Calculation ↓		Total Annual Recharge (in)	Total Annual Recharge (cu.ft)
% of Pre-Developed Annual Recharge to Preserve =	100%		
Post-Development Annual Recharge Deficit=	103,435	(cubic feet)	
Recharge Efficiency Parameters Calculations (area averages)			
RWC=	3.94	(in)	DRWC= 3.94 (in)
ERWC =	0.93	(in)	EDRWC= 0.93 (in)

FIGURE 10-K

Project Name		Description		Analysis Date		BMP or LID Type					
Sample Project		This is a test application		09/01/03							
Recharge BMP Input Parameters				Root Zone Water capacity Calculated Parameters				Recharge Design Parameters			
Parameter	Symbol	Value	Unit	Parameter	Symbol	Value	Unit	Parameter	Symbol	Value	Unit
BMP Area	ABMP	6656.0	sq.ft	Empty Portion of RWC under Post-D Natural Recharge	ERWC	0.93	in	Inches of Runoff to capture	Qdesign	0.54	in
BMP Effective Depth, this is the design variable	dBMP	5.2	in	ERWC Modified to consider dEXC	EDRWC	0.93	in	Inches of Rainfall to capture	Pdesign	0.67	in
Upper level of the BMP surface (negative if above ground)	dBMPu	-5.2	in	Empty Portion of RWC under Infit. BMP	RERWC	0.74	in	Recharge Provided Avg. over Imp. Area		19.0	in
Depth of lower surface of BMP, must be >= dBMPu	dEXC	0.0	in					Runoff Captured Avg. over imp. Area		24.8	in
Post-development Land Segment Location of BMP, Input Zero if Location is distributed or undetermined	SegBMP	0	unitless								
				BMP Calculated Size Parameters				CALCULATION CHECK MESSAGES			
				ABMP/Aimp	Aratio	0.10	unitless	Volume Balance--> OK dBMP Check----> OK dEXC Check----> OK BMP Location----> Location is selected as distributed or undetermined			
				BMP Volume	VBMP	2,873	cu.ft				
Parameters from Annual Recharge Worksheet				System Performance Calculated Parameters							
Post-D Deficit Recharge (or desired recharge volume)	Vdef	103,435	cu.ft	Annual BMP Recharge Volume		103,435	cu.ft	OTHER NOTES Pdesign is accurate only after BMP dimensions are updated to make rech volume= deficit volume. The portion of BMP infiltration prior to filling and the area occupied by BMP are ignored in these calculations. Results are sensitive to dBMP, make sure dBMP selected is small enough for BMP to empty in less than 3 days. For land Segment Location of BMP if you select "impervious areas" RWC will be minimal but not zero as determined by the soil type and a shallow root zone for this Land Cover allowing consideration of lateral flow and other losses.			
Post-D Impervious Area (or target Impervious Area)	Aimp	65,340	sq.ft	Avg BMP Recharge Efficiency		76.7%	Represents % Infiltration Recharged				
Root Zone Water Capacity	RWC	3.94	in	%Rainfall became Runoff		78.3%	%				
RWC Modified to consider dEXC	DRWC	3.94	in	%Runoff Infiltrated		66.2%	%				
Climatic Factor	C-factor	1.53	no units	%Runoff Recharged		50.8%	%				
Average Annual P	Pavg	47.8	in	%Rainfall Recharged		39.7%	%				
Recharge Requirement over Imp. Area	dr	19.0	in								
<p>How to solve for different recharge volumes: By default the spreadsheet assigns the values of total deficit recharge volume "Vdef" and total proposed impervious area "Aimp" from the "Annual Recharge" sheet to "Vdef" and "Aimp" on this page. This allows solution for a single BMP to handle the entire recharge requirement assuming the runoff from entire impervious area is available to the BMP. To solve for a smaller BMP or a LID-IMP to recharge only part of the recharge requirement, set Vdef to your target value and Aimp to impervious area directly connected to your infiltration facility and then solve for ABMP or dBMP. To go back to the default configuration click the "Default Vdef & Aimp" button.</p>											

10.11.5 Stormwater Management Facility Maintenance

The design engineer shall prepare a Stormwater Management Facility Maintenance Plan in accordance with the New Jersey Stormwater Rule. At a minimum, the maintenance plan shall include specific preventative maintenance tasks and schedules. The maintenance plan shall include at a minimum the manufacturer's recommendation on the maintenance of their facility. Maintenance plan guidelines are available in the New Jersey Stormwater Best Management Practices Manual. Additional maintenance information is also provided in the NJDEP Stormwater Management Facility Maintenance Manual, including recommended maintenance tasks and equipment, inspection procedures and schedules, ownership responsibilities, and design recommendations to minimize the overall need for maintenance while facilitating inspection and maintenance tasks.

A copy of The Stormwater Management Facility Maintenance Plan shall be submitted to the Division of Operations Support for review. If NJDEP permits are required, the Stormwater Management Facility Maintenance Plan shall be submitted to the Division of Operations Support and the Bureau of Landscape Architecture and Environmental Solutions prior to the submission of the plan to the NJDEP. Upon approval of the NJDEP Permit(s), a copy of the approved permit documentation shall be provided to the Division of Operations Support.

10.12 Water Quality

10.12.1 Introduction

Stormwater runoff from NJDOT facilities and activities can be a potential contributor to water quality degradation of receiving waterbodies. This section will focus on the design of water quality facilities to treat runoff from roadways. Refer to the NJDEP Stormwater Best Management Practices Handbook and the NJDOT Soil Erosion and Sediment Control Standards Manual for water quality measures and recommendations which can be used for other NJDOT facilities and activities.

Stormwater BMPs shall be designed to reduce the post-construction load of TSS in stormwater runoff generated from the water quality storm by 80% of the anticipated load from the developed site. Subsection 10.12 and the Stormwater Best Management Practices Manual provide guidance in the planning and design of these facilities.

For those waters designated in the tables in N.J.A.C. 7:9B-1.15(c) through (g) for the purposes of implementing the Antidegradation Policies in N.J.A.C. 7:9B-1, projects involving a Category One waterbody shall be designed such that a 300-foot special water resource protection area is provided on each side of the waterbody. Encroachment within this 300-foot buffer is prohibited except in instances where preexisting disturbance exists. Where preexisting disturbance exists, encroachment is allowed, provided that the 95% TSS removal standard is met and the loss of function is addressed.

10.12.2 Methodology

The water quality design storm peak rate and volume shall be determined in accordance with N.J.A.C. 7:8 using either of the following:

- A. One year, 24-hour storm using SCS Type III rainfall distribution; or
- B. 1 1/4 inch of rainfall falling uniformly in two hours.

10.12.3 Water Quality Treatment Facilities and Design

As indicated in Subpart 10.1.1, water quality is an important consideration in roadway drainage system design. Water quality facilities should be designed in accordance with all the regulatory requirements that apply.

Examples of water quality measures include, but are not limited to:

- Extended dry detention ponds
- Wet ponds
- Vegetated or biofilter swales
- Constructed wetlands
- Infiltration basins/trenches
- Oil/water separators
- Manufactured Water Quality Treatment Devices

Additional guidance regarding the design of water quality facilities is presented in the New Jersey Stormwater Best Management Practices Manual and the following web site: <http://www.njstormwater.org>.

This section focuses on design elements of those water quality measures most applicable to roadway projects, i.e. extended dry detention ponds, wet ponds, vegetated/biofilter swales and, manufactured water quality treatment devices.

Where stormwater management facilities are proposed for roadway projects, provisions for water quality treatment should be incorporated in the facility where possible.

For example, stormwater management facilities typically contain a low level outlet for water quality storm treatment. Stormwater management for the higher intensity storms (2-year, 10-year, and 100-year) is subsequently provided above the level of the water quality storm. Note: the term "extended" indicates that the detention pond is also designed for water quality treatment.

When a detention pond is used to provide water quality treatment, the following requirements must be met:

- A. Beginning at the time of peak storage within the pond, no more than 90% of the total storm volume shall be released over a 24-hour period; the rate of release shall be as uniform as possible;
- B. The minimum outlet diameter, width or height is 2.5 inches. If this minimum outlet size does not provide for the detention times required in A above, then alternative or additional techniques for the removal of total suspended solids(TSS) shall be provided; and
- C. The species of non-invasive native vegetation used in the pond is approved by the Bureau of Landscape Architecture and Environmental Solutions and, if required, regulatory agencies.

When treatment within a pond is not feasible, the use of vegetated or biofilter swales is permissible provided that:

- A. The water velocity does not exceed 2 feet per second (fps) to allow for settlement of TSS during the water quality design storm;
- B. The slope of the swale shall not be less than 0.5 percent and the length of the swale shall be of sufficient length to allow for settlement of TSS, taking into consideration the velocity, depth of flow, and expected loading of TSS, a minimum length of 300 feet should be used for swales;
- C. The residence time, i.e. time within the swale, should be maximized as much as possible, with five minutes used as the absolute minimum;
- D. The design flow depth in mowed swales shall not exceed 3 inches for the water quality design storm. In swales with wetlands vegetation, the depth should be at least 1 ½ inches below the height of the shortest species;
- E. Trapezoidal swale bottom widths should be no less than 2 feet and side slopes should be no steeper than 2 horizontal to 1 vertical;
- F. Given the above constraints, biofilters should be designed using Manning's Equation. Recommended values of Manning's "n" are 0.020 for grass biofilters regularly mowed and those with herbaceous wetland plants, and 0.024 for infrequently mowed swales, unless other information is available.
- G. If the longitudinal slope of the swale is less than 2 percent or the water table can reach the root zone of vegetation, water-resistant vegetation shall be used to survive potential standing water conditions;
- H. Vegetation shall be used in the swale to filter out the TSS and to provide a secondary treatment by absorption of pollutants leached into the soil. Vegetation used in the swale shall be approved by the Landscape and Urban Design Unit and, if required, regulatory agencies; and
- I. Vegetated swales should not be used as the only method of water quality treatment below the final discharge of the stormwater drainage system unless there is no other feasible method of providing water quality treatment within the project area.

When other water quality measures are not feasible, the use of Manufactured Water Quality Treatment Devices are permissible. Use of Low Impact Development techniques should be utilized to the maximum extent possible. For projects that are subject to the NJDEP Stormwater Management Regulations, the design engineer must complete the Low Impact Development Checklist found in the New Jersey Stormwater Best Management Practices Manual. If the use of a Manufactured Water Quality Treatment Device is necessary to meet the minimum water quality standards, the manufactured device should be designed in accordance with the following guidelines:

- A. Use of Manufactured Water Quality Treatment Devices are limited to devices approved by the New Jersey Department of Environmental Protection (NJDEP). A Complete list of Certified Stormwater Technologies approved by the NJDEP can be found at <http://www.njstormwater.org>. Table 10-12 is a list of devices approved by the NJDEP:

Table 10-12
Approved Manufactured Water Quality Treatment Devices

Product*	Manufacturer	TSS % Removal
Stormwater Management Inc. Stormfilter	Stormwater Management, Inc.	80%
Vortechincs Stormwater Treatment System	Vortechincs Inc.	50%
High Efficiency Continuous Deflective Separator Unit	CDS Technologies	50%
Stormceptor Stormwater Treatment System	Stormceptor Group of Companies	50%
Bay Saver Separator Device	Bay Saver Technologies, Inc.	50%

*The above list represents only those treatment devices currently certified by NJDEP as of May 2005, and should not be interpreted as exhaustive, nor as an endorsement of any particular manufacturer or product. The design engineer should evaluate each product for its suitability to the particular project being designed, and is encouraged to consult periodically with NJDEP to determine whether additional products or technologies have been certified since the creation of this document.

- B. Arrange the Manufactured Water Quality devices in accordance with the New Jersey Stormwater Management BMP Manual's "Guidelines for Arranging BMPs in a Series". The design of the water quality device needs to ensure that it is located such that the structure can be easily maintained (i.e. the device is not located in the middle of a busy roadway.)
- C. Selection of the appropriate water quality device should take the frequency of the maintenance into consideration. Maintenance of the device, once it is determined to be performing as designed, should be performed at most twice a year and at least once a year. The use of replacement filters is to be discouraged.
- D. A maintenance plan shall be developed for the manufactured water quality device. The maintenance plan shall at a minimum contain specific preventative maintenance task and schedules and be in compliance with N.C.A.C. 7:8-5.8 and the Maintenance Guidelines for stormwater management measures in the New Jersey Stormwater Best Management Practices Manual.

10.12.4 Scour Considerations

Scour is to be evaluated for flood hazard and outlet pipe protection of culverts and storm sewer pipes. For flood hazard, substructure foundations need to be investigated for scour in accordance with the AASHTO LRFD NJDOT Design Manual for Bridges and Structures, Section 39. The investigation consists of determining what the

substructures are founded on; how deep the foundation is; and a decision on whether potential scour will endanger the substructure's integrity. Local scour and contraction scour need to be considered.

Scour is to be evaluated utilizing site-specific geotechnical information (e.g., soil types, d_{50} , etc.). The following data should be assessed in determining geotechnical impacts on the scour analysis:

- Review subsurface information that is provided in the Geotechnical Report.
- Evaluate historic scour related conditions and potential scour holes at the bridge site.
- Soil classification – Based on laboratory tests for grain size samples, classify the soil.

Scour depths and appropriate countermeasures can be determined through the use of the Hydraulic Engineering Circular No. 18 (HEC-18), "Evaluating Scour at Bridges", HEC-20, "Stream Stability at Highway Structures", and HEC-23, "Bridge Scour and Stream Instability Countermeasures".

Outlet protection for culverts and storm sewer pipes should be designed in accordance with Subsection 10.9, Conduit Outlet Protection.

10.13 Sample Hydrologic and Hydraulic Calculations

A sample storm sewer hydraulic computations and hydrologic pond design demonstrate the design procedure for a simple storm sewer system and pond as shown on Figure 10-M. For this sample, design a new land service highway through a meadow in Woodbine, NJ.

Obtain T_c for overland flow to inlets 1, 3 and 4 (based on the hydraulically most distant point) (see Subpart 10.3.2) Obtain T_c from Figure 10-N.

Inlet #1

Ground Cover is grass

Overland flow length = 800 ft

Elevation at farthest point = 112 ft

Elevation at inlet = 98 ft

$H = 14$ ft

From Figure 10-N, (overland flow T_c)

$T_c = 6$ minutes, multiply by 2 for grass

$T_c = 12$ minutes

Inlet #3

Ground cover is grass

Overland flow length = 980 ft

Elevation at farthest point = 98 ft

Elevation at inlet = 96 ft

$H = 2$ ft

From Figure 10-N

$T_c = 17$ minutes, multiply by 2 for grass

$T_c = 34$ minutes

Inlet #4

Ground Cover is grass

Overland flow length (farthest point from channel) = 480 ft

Elevation at farthest point = 118 ft

Elevation of channel invert = 102 ft

$H = 16$ ft

From Figure 10-N

$T_c = 3.2$ minutes

Multiply by 2 for grass

$T_c = 6.4$ mins.

T_t through channel:

$L = 330$ ft

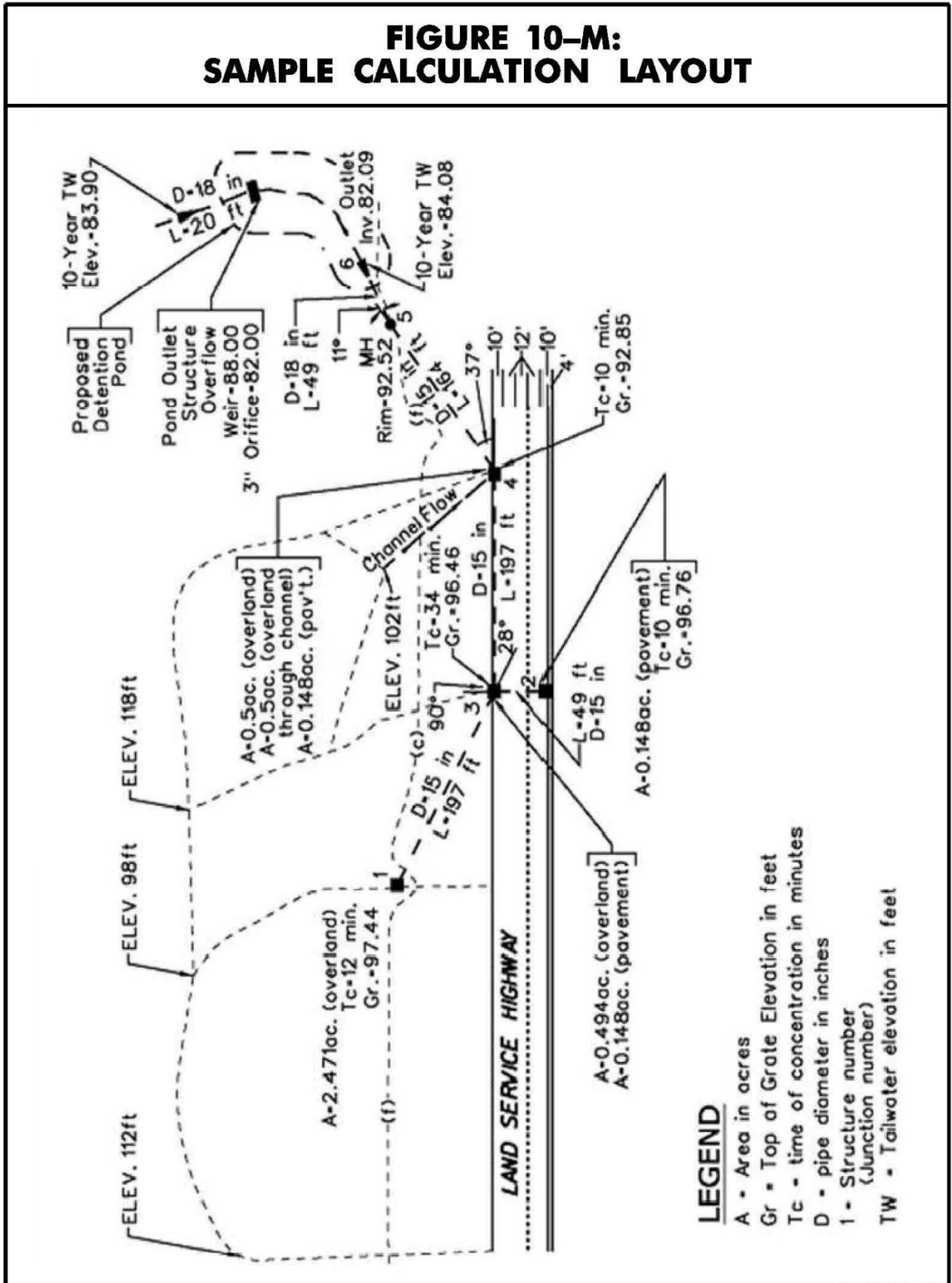
$H = 102$ ft - 93 ft = 9 ft

From Figure 10-N

$T_c = 2.5$ min.

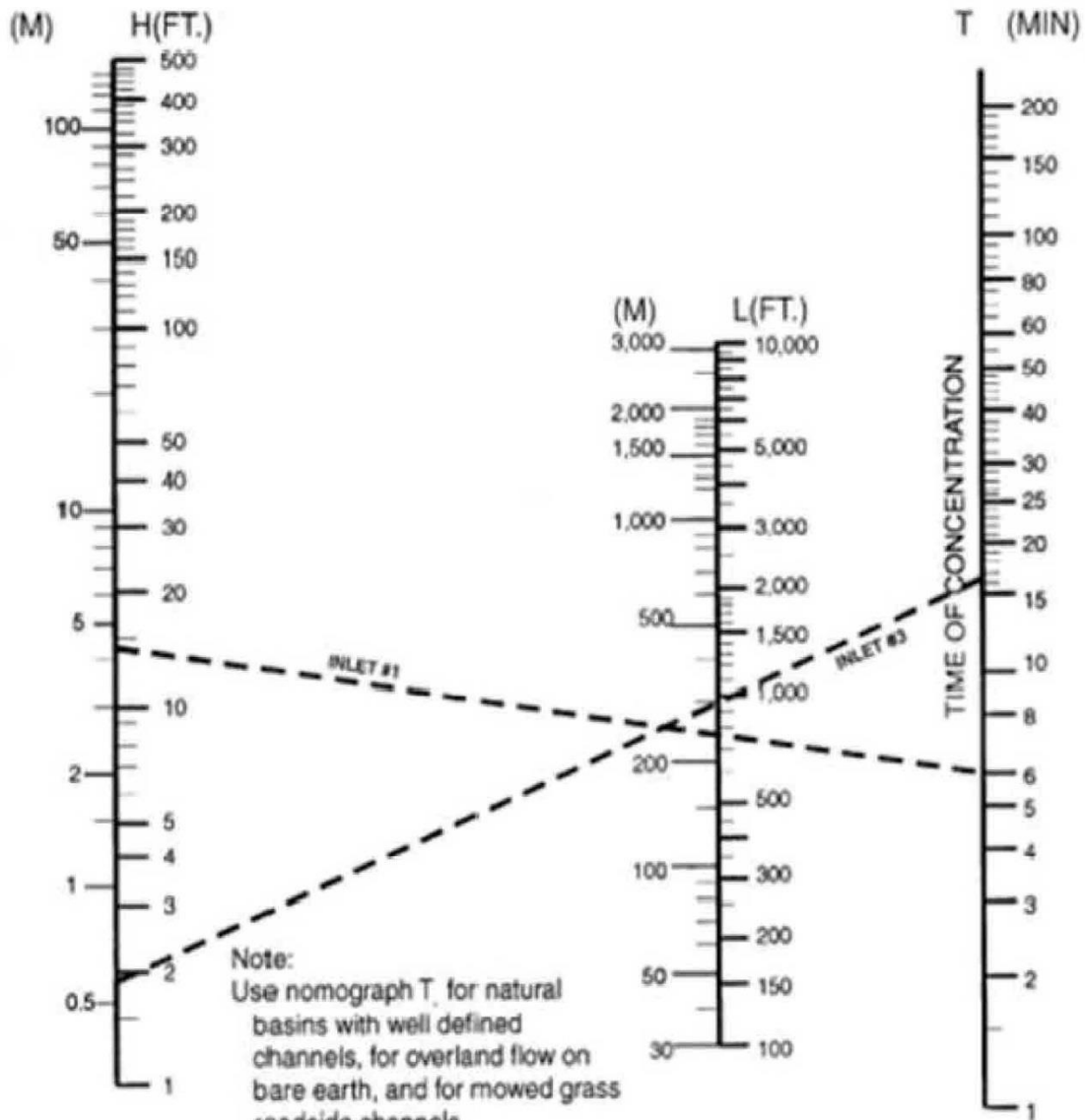
Total $T_c = 6.4$ mins. + 2.5 mins. = 8.9 minutes, use 10 minute minimum T

**FIGURE 10-M:
SAMPLE CALCULATION LAYOUT**



REV. DATE: JUNE 30, 2015

**FIGURE 10-N:
TIME OF CONCENTRATION - OVERLAND FLOW
(FOR USE IN RATIONAL FORMULA) SAMPLE**



Note:
Use nomograph T_c for natural basins with well defined channels, for overland flow on bare earth, and for mowed grass roadside channels.
For overland flow, grassed surfaces, multiply T_c by 2.
For overland flow, concrete or asphalt surfaces, multiply T_c by 0.4.
For concrete channels, multiply T_c by 0.2.

Based on study by P.Z. Kirpich, Civil Engineering, Vol. 10, No.6, June 1940, p.362

REV. DATE: JUNE 80, 2005

10.13.1 Sample Hydraulic Calculations

Using Rational formula, find 10-year runoff to each inlet: (See Subpart 10.3.3)

$$Q = CIA$$

Refer to Table 10-4 for runoff coefficients ("C"), using soil group B

Using Figure 10-A, locate the project in Woodbine, NJ. The project is located in the East Region, therefore use Figure 10-D to obtain the rain fall intensity.

Obtain rainfall intensity (I) from Figure 10-O

Inlet	T _c (min)	I (in/hr)
1	12	5.0
2	10	5.3
3	34	3.0
4	10	5.3

Inlet #1

$$Q_1 = (0.25)(5.0 \text{ in/hr})(2.471 \text{ acres}) = \mathbf{3.09 \text{ cfs}}$$

Inlet #2

$$Q_2 = (0.99)(5.3 \text{ in/hr})(0.148 \text{ acre}) = \mathbf{0.78 \text{ cfs}}$$

Inlet #3

$$Q_3 = \frac{(0.148 \times 0.99 + 0.494 \times 0.25)}{0.642} (3.0 \text{ in/hr})(0.642 \text{ acre}) = \mathbf{0.81 \text{ cfs}}$$

Inlet #4

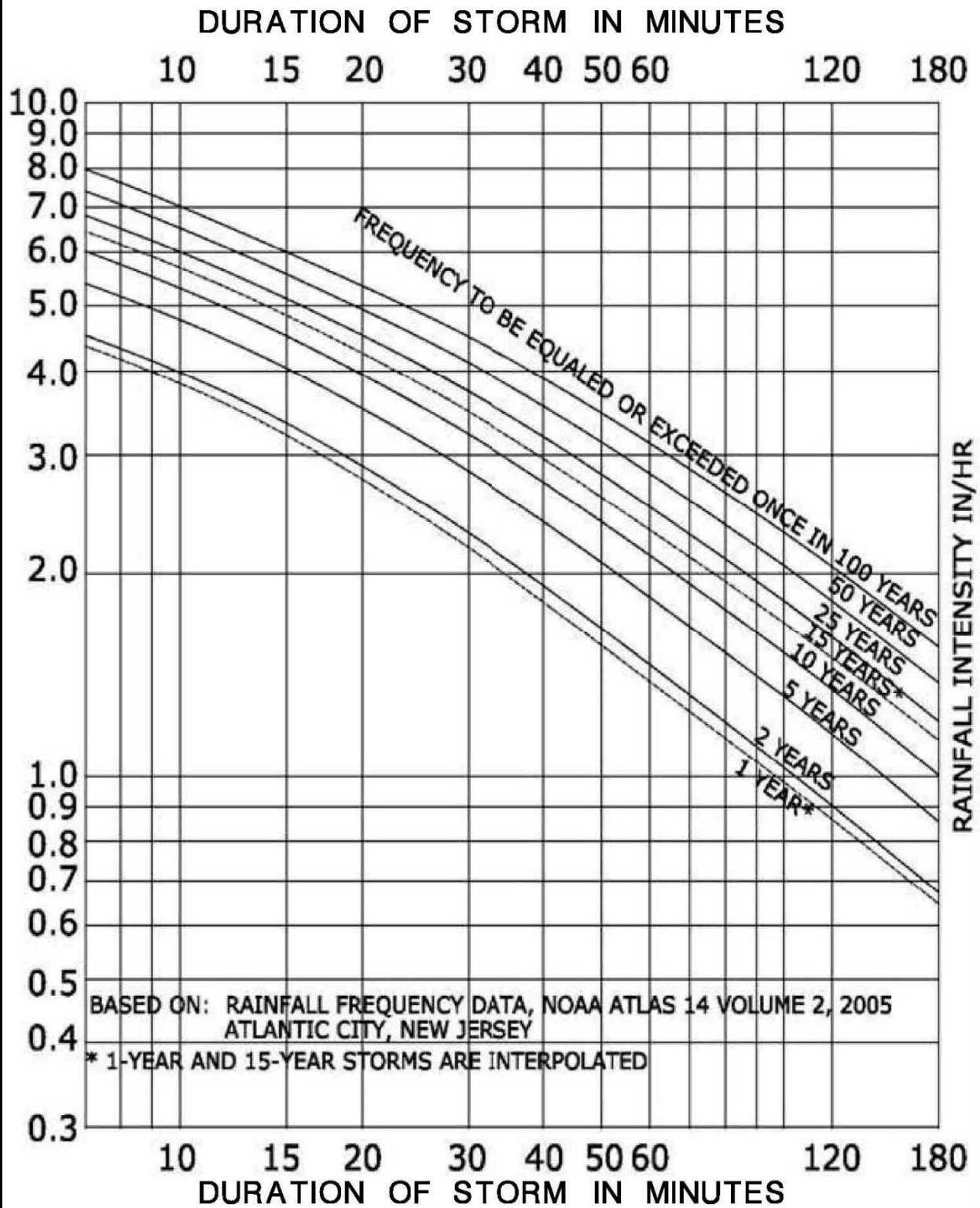
$$Q_4 = \frac{(0.148 \times 0.99 + 1.0 \times 0.25)}{1.148} (5.3 \text{ in/hr})(1.148 \text{ acre}) = \mathbf{2.10 \text{ cfs}}$$

Compute gutter spread width, intercepted flow, bypass flow and efficiency for each roadway inlet: (See Manual Subparts 10.5.5 and 10.5.7)

Inlet #2 (type D-1 inlet)

Q= 0.78 cfs	S _x =0.04	S= 0.03	n=0.013	T _{all} =4 ft(inside shldr. width) + 4 ft(1/3 of inside lane)=8 ft (allowable spread)
-------------	----------------------	---------	---------	--

**FIGURE 10-O:
RAINFALL INTENSITY - DURATION FREQUENCY CURVES
SAMPLE**



REV. DATE: JUNE 30, 2015

Using a modification of the Manning equation, obtain gutter spread width:

$$Q = \frac{0.56 S_x^{1.67} S^{0.5} T^{2.67}}{n}, \text{ solve for } T \quad (\text{Subpart 10.5.4})$$

$$T^{2.67} = \frac{0.78}{(0.56/0.013)(0.04)^{5/3}(0.03)^{1/2}}$$

T=3.20 ft < T_{all} of 8 ft, OK

$$y = TS_x \quad (\text{Subpart 10.5.4})$$

$$y = 3.20 \text{ ft } (0.04) = 0.128 \text{ ft}$$

For the standard NJDOT bicycle safe grate, the following equation shall be used to obtain inlet interception:

$$Q_i = \frac{16.88(y)^{1.54}(S)^{0.233}}{S_x^{0.276}} \quad (\text{Subpart 10.5.7})$$

$$Q_i = \frac{16.88(0.128)^{1.54}(0.03)^{0.233}}{0.04^{0.276}} = 0.76 \text{ cfs}$$

Determine bypass runoff = total runoff - intercepted runoff

$$\text{Bypass flow} = 0.78 - 0.76 = 0.02 \text{ cfs}$$

(0.02 cfs would bypass to downstream inlet)

Check inlet efficiency:

$$\frac{0.76 \text{ cfs}}{0.78 \text{ cfs}} = \mathbf{0.97 > 75\% , OK}$$

Inlet #3 (type B inlet)

$$Q=0.81 \text{ cfs}$$

$$s_x=0.04$$

$$S=0.03$$

$$T_{\text{all}}=10 \text{ ft}$$

Using the above equation to solve for T:

$$T^{2.67} = \frac{0.81}{(0.56/0.013)(0.04)^{5/3}(0.03)^{1/2}}$$

T=3.24 ft < T_{all} of 10 ft, OK

Compute inlet interception:

$$\text{When } T=3.24 \text{ ft, } y=3.24(0.04) = 0.130 \text{ ft}$$

$$Q_i = \frac{16.88(0.130)^{1.54}(0.03)^{0.233}}{0.04^{0.276}} = 0.78 \text{ cfs}$$

$$\text{Bypass flow} = 0.81 - 0.78 = 0.03 \text{ cfs}$$

(0.03 cfs will bypass to inlet #4)

Check inlet efficiency:

$$\frac{0.78}{0.81} = \mathbf{0.96 > 0.75, \text{ OK}}$$

Inlet #4 (type B inlet)

$$Q=2.10 \text{ cfs} + 0.03 \text{ cfs (bypass from inlet \#3)} = 2.13 \text{ cfs}$$

$$s_x=0.04$$

$$S=0.025$$

$$T_{\text{all}}=10 \text{ ft}$$

Using above equation to solve for T:

$$T^{2.67} = \frac{2.13}{(0.56 / 0.013)(0.04)^{5/3} (0.025)^{1/2}}$$

$$\mathbf{T=4.83 \text{ ft} < T_{\text{all}} \text{ of } 10 \text{ ft, OK}}$$

Compute inlet interception:

$$\text{When } T=4.83 \text{ ft, } y=4.83(0.04) = 0.193 \text{ ft}$$

$$Q_i = \frac{16.88(0.193)^{1.54} (0.025)^{0.233}}{0.04^{0.276}} = 1.38 \text{ cfs}$$

Check inlet efficiency:

$$\frac{1.38}{2.13} = \mathbf{0.65 < 0.75}$$

Since the efficiency is <75%, this inlet should be moved upstream.

When the spread width exceeds the shoulder width, the excess runoff extends into the adjacent lane, which typically has a different cross slope than the shoulder. The following example presented the computational procedure to determine the spread.

Obtain spread width for a composite gutter section:

Say conditions for inlet #2 are such that:

$$Q= 1.836 \text{ cfs}$$

$$S_x=0.04\text{ft/ft}$$

$$S= 0.005 \text{ ft/ft}$$

$$n=0.013$$

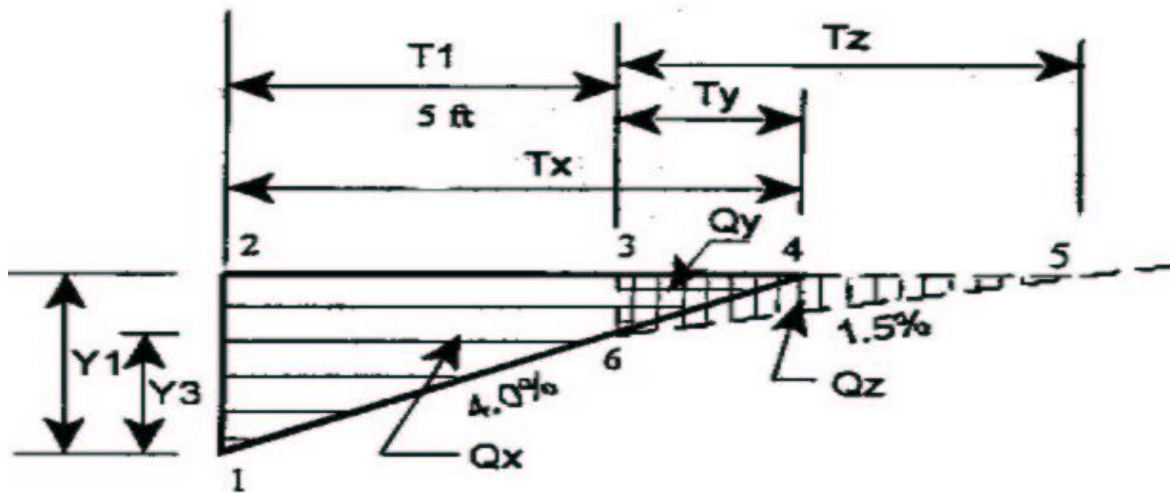
T (allowable) = 5.0 ft (inside shldr. width) + 4.0 ft (1/3 of inside lane) = 9.0 ft

Using above equation:

$$T^{2.67} = \frac{1.836}{(0.56/0.013)(0.04)^{5/3}(0.005)^{1/2}}$$

$$T = 6.17 \text{ ft}$$

Inside shoulder width is 5 ft, therefore, spread is beyond shoulder into adjacent through lane. Since the cross slope of the through lane differs from that of the shoulder, a composite gutter spread calculation must be performed to determine correct spread width.



Initially, a depth is assumed (y_1). Q_x , Q_y and Q_z are then calculated using the above equation. The flow contained in the composite section (Q_t) is equal to $Q_x + Q_z - Q_y$. This process is repeated until $Q_t = Q$ (actual flow in the gutter). T (actual spread width) is equal to $T_x + T_z - T_y$.

Given $T_1 = 5 \text{ ft}$, $y_3 = 5 \text{ ft}(0.04) = 0.20 \text{ ft}$

Find Q_x (Triangle 1,2,4)

Assume $y_1 = 0.25 \text{ ft}$, $T_x = 6.25 \text{ ft}$

$$Q_x = \frac{0.56 (0.04)^{5/3} (0.005)^{1/2} (6.25 \text{ ft})^{2.67}}{0.013}$$

$$Q_x = 1.90 \text{ cfs}$$

Find Q_z (Triangle 3,5,6)

$$T_z = \frac{(y_1 - y_3)}{0.015} = \frac{0.05}{0.015} = 3.33 \text{ ft}$$

$$Q_z = \frac{0.56 (0.015)^{5/3} (0.005)^{1/2} (3.33)^{2.67}}{0.013}$$

$$Q_z = 0.07 \text{ cfs}$$

Find Q_y (Triangle 3,4,6)

$$T_y = \frac{(y_1 - y_3)}{0.04} = 1.25 \text{ ft}$$

$$Q_y = \frac{0.56 (0.04)^{5/3} (0.005)^{1/2} (1.25)^{2.67}}{0.013}$$

$$Q_y = 0.03 \text{ cfs}$$

$$Q_t = 1.90 \text{ cfs} + 0.07 \text{ cfs} - 0.03 \text{ cfs} = 1.94 \text{ cfs}$$

$Q_t = Q$, therefore, assumed depth is correct

Calculate T (actual spread width) ($T_1 + T_z - T_y$)

$$T = 6.25 \text{ ft} + 3.33 \text{ ft} - 1.25 \text{ ft} = 8.33 \text{ ft}$$

$$T = 8.33 \text{ ft} < 9 \text{ ft}, \text{ OK}$$

Compute inlet interception:

$$Q_i = \frac{16.88 (0.25)^{1.54} (0.005)^{0.233}}{0.04^{0.276}} = 1.41 \text{ cfs}$$

Check inlet efficiency:

$$\frac{1.41}{1.836} = 0.77 \geq 0.75, \text{ OK}$$

Obtain gutter spread width for inlet at low point: (See Manual Subpart 10.5.8)

Utilize same conditions at inlet #4, except $s=0\%$ (sag condition)

$$Q = 20.88 (y)^{1.5} \text{ (for weir flow)}$$

Solving for y :

$$y = \frac{Q^{0.67}}{7.58} = \frac{2.10^{0.67}}{7.58}$$

$y = 0.22 \text{ ft}$ (Less than 0.75 ft, therefore use of weir equation is acceptable)

$$T = \frac{d}{S_x} \quad (d=y)$$

$$\text{When } d = 0.22 \text{ ft}, T = \frac{0.22}{0.04} = 5.50 \text{ ft}$$

$$T = 5.50 < T_{\text{all}} \text{ of } 10 \text{ ft}, \text{ OK}$$

Compute storm drain pipe sizes for network using sample forms at end of this subsection. (See Manual Subparts 10.6.4 and 10.6.5)

Backup Computations for Pipe Travel Time for Figure 10-F

Find T_c for pipe flow for partly full pipe (pipe 1-3):

(See Manual Subpart 10.3.5)

From column 12 - $Q = 3.11 \text{ cfs}$

From column 15 - $Q_c = 4.95$ cfs

$$\frac{3.11}{4.95} = 0.63 \text{ (63\% full)}$$

$$4.95$$

From Concrete Pipe Design Manual chart, "Relative Velocity and Flow in Circular Pipe", at 63% full, $v=1.06$ of full velocity.

$$v_{full} = 4.03 \text{ ft/s}, v_{des} = 4.03 \text{ ft/s}(1.06) = 4.27 \text{ ft/s}$$

$$T_t = \frac{197 \text{ ft}}{4.27 \text{ ft/s}} = 0.77 \text{ min.}, T_c = 12.77 \text{ min. (12 min. to Junction 1 + 0.77 min. travel time in pipe)}$$

Since T_c at inlet 3 from overland flow is 34.0 min. > 12.77 min., use 34.0 min.

PRELIMINARY STORM DRAIN COMPUTATION FORM [SAMPLE]	FIGURE 10-P

Computed: _____ **Date:** _____

Route: _____

Checked: _____ **Date:** _____

Section: _____

County: _____

Station and Offset (1)		L (ft) (2)	Drainage Area "A" (Acres)		Runoff Coeff- ficient "C" (5)	"A" x "C"		Flow Time "Tc" (min.)			Rainfall "I" in/hr (11)	Total Runoff Q=CIA ft ³ /S (12)	Dia. Pipe ft (13)	Slope ft/ft (14)	Capacity Full ft ³ /S (15)	Velocity ft/s		Invert Elevation		
Junction From	Junction To		Incre- ment (3)	Total (4)		Incre- ment (6)	Total (7)	Overlan- d To Inlet (8)	In U/S Pipe (9)	Cum. Total in Pipe* (10)						Flowing Full (16)	Design Flow (17)	U/S End (18)	D/S End (19)	
1	3	197	2.471	2.471	0.25	0.618	0.618	12.0	--	12.0	5.0	3.09	15	0.005	4.95	4.03	4.38	88.68	87.70	
2	3	49	0.148	0.148	0.99	0.147	0.147	10.0	--	10.0	5.3	0.779	15	0.005	4.95	4.03	3.03	91.37	91.14	
3	4	197	0.494		0.25	0.124		34.0												
			0.148		0.99	0.147			0.75	34.0	3.0									
				3.261			1.036		(Line 1-3)			3.11	15	0.02	9.90	8.06	7.39	87.60	83.66	
4	5	164	1.0		0.25	0.25		10.0												
			0.148		0.99	0.147			0.39											
				4.41			1.433			34.39	3.0	4.30	15	0.006	5.42	4.42	4.97	83.56	82.58	
5	6	49	--	4.41			1.433		0.37	34.76	3.0	4.30	18	0.005	8.05	4.55	4.73	82.35	82.09	

• For Time of Concentration, use larger of overland flow to inlet or cumulative time in pipe.

HYDRAULIC GRADE LINE COMPUTATION FORM [SAMPLE]	FIGURE 10-Q

Computed: _____

Date: _____

Route: _____

Checked: _____

Date: _____

Section: _____

County: _____

Station & Offset		Q	V	R	L	n	h	H_f	H_e	H_i	H_s	H_t	TW	HGL	TOS	CL	
(1)	(2)	(3)	(4)	(5)	(6)	(7)	(8)	(9)	(10)	(11)	(12)	(13)	(14)	(15)	(16)	(17)	
Junction From	Junction To	Dia. ft	Flow ft ³ /S	Vel. ft/s	Hydraulic radius ft	Length ft	Manning's	Vel. Head ft	Fric. Loss ft	Exit Loss ft	Entr. Loss ft	Struct. Loss* ft	Total Head Loss ft	Tail-water Elev. ft	Head-water Elev. ft	Top of Struct. Elev. ft	TOS-HGL ft
6 (outlet)	5	18	4.30	2.43	0.375	49	0.012	0.092	0.069	0.092	--	0.01	0.171	84.08	84.251	92.52	8.269
5	4	15	4.30	3.50	0.312	164	0.012	0.190	0.616	--	--	0.08	0.696	84.251	84.947	92.85	7.903
4	3	15	3.11	2.53	0.312	197	0.012	0.099	0.387	--	--	0.03	0.417	84.947	85.364	96.46	11.096
3	2	15	0.779	0.63	0.312	49	0.012	0.006	0.006	--	0	--	0.006	85.364	85.37	96.79	11.42
3	1	15	3.09	2.52	0.312	197	0.012	0.099	0.384	--	0.020	--	0.404	85.37	85.774	97.44	11.666

$h = \text{Velocity head, } = \frac{(V)^2}{2g}$
 $H_i = \text{Entrance Loss } = K_i(V)^2/2g$
Refer to Table 10-10 for values of K_i

$H_f = \text{Friction Loss, } = \frac{29.1N^2L}{R^{1.33}} \times \frac{(V)^2}{2g}$
 $H_e = \text{Exit Loss, } H_e = (V)^2/2g$

* For structural (junction) losses in inlets, manholes, see Figure 10-R.

STRUCTURAL AND BEND LOSS COMPUTATION FORM [SAMPLE]	FIGURE 10-R

Computed: _____ **Date:** _____

Route: _____

Checked: _____ **Date:** _____

Section: _____

County: _____

(1)	(2)	Q (3)	v (4)	v ² / 2g (5)	(6)	(7)	K _s (8)	H _s (9)	A (10)	K _b (11)	H _b (12)	H _s + H _b (13)
Junction Station & Offset	Downstream Dia. ft	Downstream Flow ft ³ /S	Downstream Velocity ft/s	Velocity Head ft	Junction Type (L,N or O)	Flow Type (P or O)	Structural Loss Coeff.	Structural Loss ft	Angle deg.	Bend Factor	Bend Loss ft	Structural Loss + Bend Loss ft
6	--	--	0	0	--	--		--	--	--	--	--
5	18	4.30	2.43	0.09	N	P	0.3	0.03	11	0.15	0.01	0.04
4	15	4.30	3.50	0.19	N	P	0.3	0.06	37	0.41	0.08	0.14
3	15	3.11 3.11	2.53 --	0.10 --	L	P	1.0	0.10 --	28 --	0.33 --	0.03 --	0.13 --
2	15	0.779	0.44	0.003	N	P	--	--	--	--	--	--
1	15	3.09	1.75	0.05	N	P	--	--	--	--	--	--

H_s = Structural Loss = K_s X $\frac{(V)^2}{2g}$, K_s from Table 10-11

H_b = Bend Loss = K_b X $\frac{(V)^2}{2g}$, K_b from Figure 10-I

- NOTES:
- | | |
|---------------------------|------------------|
| 1) Junction Type | 2) Flow Type |
| L = with Lateral | P = Pressure |
| N = with No Lateral | O = Open Channel |
| O = with Opposed Laterals | |

10.13.2 Sample Hydrologic Calculations

For the same project, design a pond so that the post-construction peak runoff rates for the 2-year, 10-year, and 100-year storm events are 50%, 75%, and 80%, respectively, of the pre-construction rates. Due to the complexity of designing a pond, use of computer software is encouraged. In this example, software was used and the input and output is summarized below.

Determine what the pre-construction and post-construction discharges are without a detention pond.

Using TR-55 the discharges are the following:

Area Name	Area (Acre)	Curve Number	2-Year Flow (cfs)	10-Year Flow (cfs)	100-Year Flow (cfs)
Existing 1	2.471	58	0.51	2.72	8.96
Existing 2	0.148	58	0.03	0.16	0.54
Existing 3	0.642	58	0.13	.71	2.33
Existing 4	1.148	58	0.24	1.27	4.16
Total	4.409	--	0.92	4.86	15.99
Proposed 1	2.471	58	0.51	2.72	8.96
Proposed 2	0.148	98	0.40	0.63	1.09
Proposed 3	0.642	67	0.26	.76	1.97
Proposed 4	1.148	63	0.47	1.73	4.90
Total	4.409	--	1.45	5.52	16.20

With the aid of computer software, design a pond so that the post-construction peak runoff rates for the 2-year, 10-year, and 100-year storm events are 50%, 75%, and 80%, respectively, of the pre-construction rates. The pond should have design flows as follows:

	Inflow (cfs)	Design Discharge (cfs)
2-year	0.92	0.46
10-year	4.86	3.65
100-Year	15.99	12.79

Design a pond with a bottom length of 75 feet, bottom width of 40 feet and with 2:1 side slopes. The pond will be located as shown on Figure 10-M. The outlet structure will be a riser inlet box with a 3" orifice at elevation 82.0 feet and an overflow weir at elevation 88.0 feet. The outlet pipe from the outlet structure is an 18" reinforced concrete pipe. Note that different pond and outlet structure configuration may need to be tried for the pond to perform at the design discharge. Use of a pond sizing wizard may be helpful in determining a starting point. If the required pond size is too large for the proposed project, multiple smaller ponds may be used for detention. The pond, as designed, has the following discharges:

	Discharge (cfs)	% of Pre- Construction Rates	Check
2-year	0.16	17	OK
10-year	3.60	74	OK
100-year	11.02	69	OK

References

1. American Iron and Steel Institute, *Handbook of Steel Drainage and Highway Construction Products, Fifth Edition*, 150 East 42nd Street, New York, 1994. Harrison, L.J., Morris, J.L., Normann, J.M., and Johnson, F.L.
2. American Concrete Pipe Association, *Concrete Pipe Design Manual*, Revised April 2004.
3. *Aluminum Storm Sewers - Corlix/Riveted Pipe/Structural Plate*, 4th Edition.
4. Federal Highway Administration, *Design Charts For Open-Channel Flow*, U.S. Government Printing Office, Washington, DC. 1961. (Hydraulic Design Series No. 3).
5. *Drainage of Highway Pavement*, FHWA, U.S. Government Printing Office, Washington, DC. (HEC No. 12), March 1984.
6. NOAA Atlas 14, Volume 2, *Precipitation-Frequency of the United States*, June 2, 2005.
7. *Design of Urban Highway Drainage-The State of the Art*, USDOT, FHWA - TS-79-225, August 1979.
8. FHWA, *Hydraulic Design of Highway Culverts*, U.S. Government Printing Office, Washington, DC. September 2004. (HDS No. 5).
9. NJDEP Technical Manual, *Flood Hazard Area Control Act Rules* (draft)
10. *Fundamental of Urban Runoff Management: Technical and Institutional Issues*, Terrene Institute, Washington, D.C., Horner, R. Skupien, J.J., Livingston, E.H., and Shaver, H.E., August 1994.
11. New Jersey Department of Environmental Protection, *New Jersey Stormwater Best Management Practices Manual*, April 2004.
12. *New Jersey Stormwater Management Rule*, N.J.A.C. 7.8
13. *New Jersey Surface Water Quality Standards*, N.J.A.C. 7:9B
14. New Jersey Department of Environmental Protection, *Highway Agency Stormwater Guidance Document*, August 2004
15. New Jersey Department of Transportation, *Bridge and Structures Design Manual, Section 46, Scour at Bridges*.
16. Federal Highway Administration, *Evaluating Scour at Bridges, 4th Edition*, May 2001 (HEC-18).
17. Federal Highway Administration, *Stream Stability at Highway Structures, Third Edition*, March 2001, (HEC-20).
18. Federal Highway Administration, *Bridge Scour and Stream Instability Countermeasures, 2nd Edition*, March 2001, (HEC-23).
19. New Jersey Pollutant Discharge Elimination System (NJPDES) Highway Agency Stormwater General Permit.

Section 11 - Highway Lighting Systems

11.1 General

This section provides for developing uniformity in the design and plan preparation of highway lighting systems, and conforming to Department policy.

Complying with all of the design criteria is sometimes difficult. It will require some judgment on the part of the designer to draw the necessary balance. However, it is necessary that the criteria be followed as closely as possible in order to achieve uniformity of design in highway lighting systems. It is recognized that situations will occur where good engineering judgment dictates deviation from this Department policy. Any such deviation shall be detailed in writing and submitted for approval to the Manager, Bureau of Traffic Engineering (BTE).

It is not the intent of this section to reproduce all the information that is adequately covered by textbooks and other publications that are readily available to the designer. This section, when used in conjunction with engineering knowledge of highway lighting design and good judgment, should enable the designer to perform their job more efficiently.

The terminology used in this manual, unless stated otherwise, is as defined in *AASHTO An Informational Guide for Roadway Lighting*.

11.2 Reference Publications

- AASHTO, *An Informational Guide for Roadway Lighting*
- FHWA, *Roadway Lighting Handbook*
- FHWA, *Manual on Uniform Traffic Control Devices (MUTCD)*
- Illuminating Engineering Society of North America (IESNA)
Applicable Lighting Publications.
- SPECIFICATIONS:
 - NJDOT Standard Specifications for Road and Bridge Construction
 - NJDOT Supplemental Specifications
 - NJDOT Special Provisions
- NJDOT Standard Electrical Details
- NJDOT Electrical Material Specifications
- NFPA National Electric Code (NEC)
- NJDOT Sample Plans
- NJDOT CADD Manual

All publications shall be the latest edition.

11.3 General Design Criteria

11.3.1 Warrants for Highway Lighting

These warrants are for highway lighting only and the warrants for intersection lighting are in Section 11.8.

Step 1

Prior to the actual design of a highway lighting system, the designer must determine if highway lighting at a particular section, area or location is actually warranted. To demonstrate this need a system of warrants has been developed. The American Association of State Highway and Transportation Officials (AASHTO) warrants shall be investigated before a final determination is reached. If highway lighting is warranted based on the following (except for underdeck/tunnel lighting), then the designer shall proceed to Step 2.

- A. Continuous Freeway Lighting - One of the following AASHTO warrants must be met to consider continuous lighting:
 - CFL-3
 - CFL-4
 - Special considerations
- B. Complete Interchange Lighting - One of the following AASHTO warrants must be met to consider complete interchange lighting:
 - CIL-1 plus CIL-2
 - CIL-3
 - CIL-4
 - Special considerations
- C. Partial Interchange Lighting - One of the following AASHTO warrants must be met to consider partial interchange lighting:
 - PIL-1 plus PIL-2
 - PIL-3
 - Special Considerations
- D. Underdeck Lighting or Tunnel Lighting - AASHTO warrants must be met to consider underdeck and/or tunnel lighting. If lighting is warranted, the designer shall prepare the design and skip Step 2.
- E. Additional Design Considerations - Additional lighting shall be considered warranted for ramps, mainline or acceleration lanes for any of the following reasons:
 1. Ramps
 - Inside radius of entrance or exit ramp is less than 150 feet.
 - Accident data in the ramp area indicates a problem exists.
 2. Acceleration Lanes
 - Stop before acceleration lane.

- Grade and/or curvature presents a visibility problem, which cannot be corrected through other means.
 - Sidewalks exist to permit pedestrians to cross at the entrance or terminal of a ramp.
3. Main Line
- Grade and/or curvature presents a visibility problem, which cannot be corrected through other means.
 - Bridges without shoulders.

The designer shall obtain the accident data of the location in order to determine the night to day accident ratio. The ratio could dominate the determination if highway lighting is required.

Step 2

If lighting is warranted based on the AASHTO warrants, then the need for lighting on a particular highway or interchange must be considered utilizing the appropriate evaluation form described below. The designer shall assume the evaluation forms (Lighting Forms 1-8) refer to the mainline highway unless specifically noted otherwise. Direct any questions in writing to the Manager in the Bureau of Traffic Engineering.

- A. Continuous Lighting (Freeway) - If warranted, Lighting Form 1 is to be utilized to evaluate the need for continuous lighting for the actual highway being considered. For new highways or new alignments Lighting Form 3 is to be utilized to evaluate the need for continuous lighting. All highways (traveled lanes) are to be illuminated except express lanes separated from local lanes by concrete island, barrier curb or grass.
- B. Complete and Partial Interchange Lighting - If warranted, Lighting Form 2 is to be utilized to evaluate the need for complete or partial interchange lighting for the actual highway and interchange being considered. For new highways or new alignments Lighting Form 4 is to be utilized to evaluate the need for complete or partial interchange lighting. Unless otherwise directed, the deceleration and adjacent lanes must be illuminated.
 - Deceleration lane lighting shall be installed for the safe stopping distance (based on the design speed limit) from the physical gore area. Only two units shall be installed past the physical gore area (one unit in the ramp area and one unit along the main line). See Figure 11-A. The clear zone, as shown on Figure 11-A, is defined as a 30 foot minimum distance.
 - Acceleration lanes are not to be illuminated. Acceleration lanes are considered to begin at the entrance gore area.
- C. Non-Controlled Access Facility (Land Service Highway) Lighting - Lighting Form 5 is to be considered. For new highways, or new alignments Lighting Form 6 is to be utilized to evaluate the need for continuous lighting.

11.3.2 Selection of Types of Highway Lighting

The Department currently utilizes two types of highway lighting systems. The designer shall investigate the lighting system options available. The use of either one type or a combination of the following types of lighting systems is acceptable:

- High Mast Lighting System - A system utilizing a mounting height of 100 feet with a cluster of a maximum of eight 400 watt high pressure sodium luminaires.
- Conventional Lighting System - A system utilizing mounting heights of 26 feet with 150 watt, 40 feet with 250 watt high pressure sodium conventional luminaires.

Before choosing a particular system, the designer shall first investigate the various types of lighting listed below:

- Tower lighting shall be considered first for full interchange lighting. A 400 watt cutoff type luminaire is preferred; non-cutoff luminaires can be utilized if the designer can justify their use. A public hearing shall be held to advise the local residents that tower lighting shall be installed. All design data, including lighting levels, must be available for the public's review and comments.
- Conventional Lighting (full cutoff luminaires) shall be considered as a second choice for full interchange lighting.
- Conventional Lighting (cutoff luminaires) shall be considered as a third choice for full interchange lighting.
- Conventional Lighting (semi-cutoff luminaires) shall be considered as a fourth choice for full interchange lighting.
- The use of non-cutoff luminaires is discouraged. If the designer feels their use is warranted, a written justification with the design calculations must be provided.
- Conventional lighting (full-cutoff, cutoff & semi-cutoff) shall be considered first for continuous mainline or partial interchange lighting. A 40 foot mounting height standard for mainline (250 watt luminaire) and a 26 foot mounting height standard for ramps (150 watt luminaire).

Investigate the environmental impact, especially on residences, of each system. The designer shall recommend to the Bureau of Traffic Engineering of the elimination of any systems that have serious and unacceptable environmental impacts. The use of external luminaire shields may be used to minimize the glare of a conventional lighting system.

Upon approval, the designer shall then address, analyze and compare such determining factors as initial installation cost, maintenance costs, and energy consumption costs of the remaining system(s). All illumination and electrical design shall meet criteria as specified hereinafter. Before work commences on the lighting design, the designer must request approval of all design parameters by the Bureau of Traffic Engineering.

The designer shall be prepared to present, explain and defend his lighting system choice and design at any public or other meetings, as required. Prepare 30' scale drawings of all systems to be included with the report, and based upon investigations and analyses, and make a recommendation to the Department of the system best suited to the project.

The designer shall not intermix a Department aluminum lighting system within a utility company wood pole transmission system.

The designer is responsible for locating, identifying and certifying the horizontal and vertical clearances of the utility company's primary (750 volts or more) and secondary power lines and shall assure that the minimum clearances are in accordance with the *New Jersey Administrative Code Chapter 25 Utility Accommodation, Section 16:25-5.3 (c)*. The designer shall coordinate the electrical design work with the present and future plans of the utility companies. All overhead and underground utilities must be shown on the plans. There shall be no conflicts with the lighting installation. The Designer must resolve all utility conflicts.

When utility poles are required to be relocated and wood pole lighting shall be the sole source of illumination for a section of highway, the designer shall space and position utility poles, through the utility agreement in conformance with the *New Jersey Administrative Code Chapter 25 Utility Accommodation, Section 16:25-5.4 (b) and 5.5 (a through i)*, to produce a suitable lighting design.

11.3.3 Level of Illuminance

Provide an average maintained horizontal illuminance of 0.6 to 0.8 footcandles on mainline highways and ramps.

11.3.4 Uniformity of Illuminance

Design for uniformity of illuminance on various highways shall produce a uniformity ratio of 3:1 to 4:1 or better with a 0.2 footcandle minimum level. The ratio is defined as the average to minimum illuminance.

11.3.5 Basis for Lighting Calculation

A. Common Criteria

The following are common for all types of highway lighting systems:

- Photometric Data - The Photometric data utilized in all calculations shall be the latest data available from the Bureau of Traffic Engineering available upon written request.
- High Pressure Sodium Lamps - High pressure sodium lamps with the following initial lumens shall be used:

Wattage	ANSI Designation	Rated Avg. Life Hours	Initial Lumens
150	S55SC-150	24,000	16,000
250	S50VA-250	24,000	27,500
400	S51WA-400	24,000	50,000

- Maintenance Factors - All lighting Systems depreciate with time. The design values shall consider appropriate reduction in initial illumination values. The maintenance factor to be utilized is 0.75; 0.68 for ambient areas considered dirty.

B. High Mast Lighting Systems

Base the lighting calculations to determine the required illumination on the following definitions and criteria:

- Area - only the traveled highway and ramps, including shoulders, shall be considered in the calculations.
- High Mast Lighting Standard Assembly Setback - Minimum 30 feet measured from the face of curb or edge of pavement to centerline of high mast lighting standard. A lesser setback may be used, but must be approved by the Manager of Traffic Engineering. Should a lesser setback be approved, appropriate protection must be provided.
- Luminaires - High mast type 400 watt high pressure luminaires, as per NJDOT Specification No. EB-LHPS-4. The luminaires shall produce a symmetric, long and narrow, or asymmetric distribution. A maximum of eight luminaires of the same or different distribution shall be clustered to provide the required pattern of light distribution from the high mast lighting assembly.
- Mounting Height - The tower shall be 100 feet. The actual highway elevations shall be used in the calculations.

C. Conventional Lighting System

The lighting calculations to determine the required illuminance shall be based on the following definitions and criteria:

- Roadway Width - Actual width of highway pavement considered in calculations, including shoulders, excluding medians where they exist.
- Lighting Standard Setback - As required, minimum 5'-6" measured from the face of curb or edge of pavement to centerline of lighting standard.
- Luminaire Mounting Height - For 150 watt luminaires, 26 feet. For 250 watt luminaires, 40 feet.
- Lighting Standard Bracket Arm - 8 feet or 15 feet as required. For highway widths up to 24 feet, an 8 feet bracket arm is to be used.
- Luminaire Overhang - As required.
- Luminaires - As specified in section 11.3.2

D. Spacing and Location of the Lighting Standards

Lighting standard spacing and offsets shall be as uniform as possible. If it is necessary to vary the spacing or offset, it shall be done gradually. Since a poor appearance is likely to result, lighting standards shall not be spaced closer than 100 feet except on a ramp. In general, the lighting standards shall be located as follows:

- Mainline Highways - Along outside lanes, spaced opposite or staggered to suit the geometry and to provide the best lighting uniformity. An effort shall be made to illuminate the highway from one side.
- Ramps - In order to facilitate maintenance and relamping, it is desirable to locate the lighting standard along the inside radius. A setback of 5'-6" minimum is recommended.
- Gore Area - It is desirable for a lighting standard to be located within the vicinity of an exit gore area. In no instance shall a lighting standard be located in a roadside recovery area.

- Adjacent to Overpass - Care must be taken to avoid glare from mainline lighting affecting traffic on overpasses. External luminaire shields may be used to minimize the glare, if necessary. For typical (normal vertical clearance) overpass structures, luminaires shall not be located closer than 35 feet from the face of parapets.

E. Other Considerations

The following considerations are to be incorporated in all lighting calculations:

- Selection of proper size of luminaires to accommodate the level and uniformity of illumination.
- Selection of proper length of bracket arms to provide maximum efficiency and uniformity in lighting. It should be noted that in some areas the use of two different lengths of bracket arms may meet the above requirements, but may also produce an objectionable appearance with regard to the luminaire alignment.
- Where the geometry or the uniformity ratio requirements necessitate adjustments in the calculated lighting standard spacing, closer spacing shall be used.
- Contributions from all luminaires which have an effect on the area considered shall be taken into account to obtain the footcandle values. However, luminaires located at a distance greater than eight mounting heights from the area have a very minute effect and shall be excluded from the calculations.
- When adjacent to sign structures, it is desirable to locate lighting standards equidistant from sign structures. The lighting standards shall not be located within 50 feet of the structure. Care must be taken to avoid having a lighting bracket arm and luminaire mounted at 26 feet obstruct the driver's view of the sign-legend.
- Lighting standards shall not be located on the traffic side (in front) of guide rail or any natural or man-made deflecting barrier. The location shall also consider the distance necessary for rail deflection.

11.3.6 Lighting Calculations

A. Methods of Calculation

For the preliminary design, the average point method shall be used. Use only approved lighting design programs. Any questions regarding approved software shall be directed to the Bureau of Traffic Engineering. The current photometric data to be used in the calculations shall be provided by the Department upon written request. Use specific design software for tunnel lighting.

B. Calculation Guidelines

The following are to be followed when performing the calculations:

- When a portion or section of the highway is under analysis, it shall be analyzed as a self-contained area (main area). Sub-division (sub-area) within the main area is not permitted.

- The self-contained area (main area) of analysis shall correspond to the highway geometry under investigation.
- The point to point interval shall be 5 feet longitudinally and transversely.
- The entire section of highway that is being illuminated shall be analyzed completely. It can be analyzed with many main areas.
- Luminaire layout parameters shall conform to Section 11.3.5.
- The following information shall be included with each analysis:
 1. Project identification.
 2. Plan sheet number involved in calculations.
 3. A station to station identification of the area being analyzed.
 4. The identification of each contributing luminaire being analyzed.
- The following guidelines must be adhered to when submitting the design data for review:
 1. Submit the design files in IES format on CD or DVD.
 2. Submit a hard copy of the design calculations.
- The New Jersey State Plane Coordinate System shall be used, when available for the project, for the lighting design layout.

11.3.7 Underdeck Lighting

Underdeck lighting is not installed to accent the highways beneath structures, but rather to provide the required level of illuminance to accent continuity of uniform lighting. Therefore, underdeck lighting shall only be required where this level of illuminance, due to structural limitations such as the width, skew and minimum clearance, cannot be accomplished by means of lighting standards.

Wall mounted underdeck luminaires shall be installed on pier faces and/or on abutments at a minimal mounting height of 15 feet. The pier faces or the abutment must be parallel to the highway and must be within 10 feet from the curb or edge of the highway, otherwise the luminaires shall be fastened to adapter plates installed between the bridge girders. Wall mounted underdeck luminaires installed at a mounting height of more than 15 feet shall yield better efficiency and uniformity.

Pendant type luminaires shall be mounted from the structural steel. The luminaires shall be located to facilitate maintenance and relamping. If the highway width permits, the luminaires shall be located over the shoulder. When a luminaire is suspended from a bridge structure over the traveling lane, the bottom of the luminaire shall not be lower than the bridge girder. Typical installation of a pendant type luminaire is included in the NJDOT Standard Electrical Details. A special detail may be necessary to detail the conduit layout under the structure.

For calculation purposes, the following data shall be used:

- Mounting Height - As required (15 feet nominal).
- Luminaires- 150 watt wall mounted type and pendant mounted type high pressure sodium luminaires as per the current NJDOT Specification Nos. EB-UHPS-1 and EB-UHPS-2.

- Uniformity Ratio – See Section 11.3.4.

On highways, which are not illuminated, underdeck lighting shall be provided for underpasses having pedestrian traffic. The average maintained illuminance shall be a minimum of 0.8 footcandles.

11.3.8 Conduit

Normally, conduits for all highway lighting circuits shall be 3" diameter. Application of various types of conduits shall be as follows:

A. Rigid Metallic Conduit (RMC)

- Used for underground conduits to be installed in all paved areas, excluding sidewalk areas and private driveways.
- Used for conduits to be installed transversely on side slopes.
- Used for critical areas such as where guide rail will cross the conduit run, or where sign foundations, drainage or other subsurface structures are anticipated to interfere with the conduit raceways.
- Used for conduits embedded in concrete foundations such as meter cabinet foundations.
- Used for all conduits embedded in parapets and abutment walls of structures. An approximate 5 foot section of conduit shall be extended from the wing walls. The conduit shall then be connected into a junction box near the wing walls.
- Used for all exposed conduits.

B. Rigid Non-Metallic Conduit (RNMC)

- Use 3" RNMC for all other underground conduit installations.
- Install ground wire in all RNMC.

11.3.9 Cables and Wire

All cables and wires, including neutrals, to be used for highway lighting circuits and secondary services shall conform to the specifications and shall be fully color coded. The designer shall provide, as part of the circuit diagram, the assignment of the specific color code for the lighting circuits. The designer shall calculate the voltage drop (voltage drop forms 1 and 2) and continuous load of each circuit, and the wire fill of all conduits to ensure conformance to the NEC.

11.3.10 Junction Boxes and Foundations

Junction box foundations and 18" x 36" junction boxes shall be required in a highway lighting system. In order to facilitate cable pulling and splicing, a junction box shall be installed adjacent to each lighting tower or illuminated sign structure foundation and at each end of conduit crossings under highways. Junction boxes shall be spaced at approximately 150 feet, however, if this requirement is found to conflict with the economics of a system, the Department may approve a longer spacing. Junction boxes are designed to carry a maximum of six through conduits. In cases where the number of circuits and cable sizes involved are in excess of the junction box capacity, the design shall be reexamined for an alternate layout. Two junction boxes may be installed in front of the meter cabinet (load center) to accommodate the excess conduits and cables.

11.3.11 Incoming Service

The secondary service obtainable from the local utility company's pole or manhole shall be used to service the complete installation in each area.

The designer shall prepare an ESI (electric service inquiry) for the local utility company indicating the required service and obtain their written approval including an ESI number. Information on payee of the energy charge shall be provided in the letter. Standard services available from the utility company are as follows:

- Single Phase - 3 Wire: 120/240V and 240/480V, the latter is preferred. The utility company provides this special secondary voltage to the Department exclusively. Utilized voltage shall be 240 volts.
- Three Phase - 4 Wire: 265/460V and 277/480V, dependent on the utility company. Utilized voltage shall be 265 or 277 volts.

The designer shall always consider the Single Phase option as the first choice, since this is the preferred service for the Department.

When service is obtained from a manhole, the designer shall consult the utility company for the size, location, material and termination of the service conduit. The utility company usually furnishes the service wires, however this shall be verified.

Send copies of the service confirmation letter and Electric Service Identifier (ESI ID Number) to the Bureau of Traffic Engineering.

11.3.12 Load Center Designations

Load centers shall be designated as follows:

- State Highway - Load centers for State highway lighting systems shall be designated with two letters which represent the cross street name, such as using letters LA or LN for a load center at the intersection of Route 169 and Lincoln Avenue.
- Interstate Highway - Existing load centers and future load centers on certain interstate highways have been alphabetically assigned from one end to the other throughout the highway. Some letters were reserved for the purpose of maintaining the continuity. Obtain the designation from the Bureau of Traffic Engineering when a load center is added to the interstate highway lighting system.

11.3.13 Circuitry and Other Considerations

In most cases, where the wire fill will permit, all cables for two or more lighting circuits may be installed in the same conduit.

Nominal size of cable for highway lighting circuits shall be #2 AWG. Other sizes, such as #1/0, #4 & #6 AWG, may be used and shall be approved by the Bureau of Traffic Engineering. It is reminded that, unless necessitated otherwise, variations in cable sizes shall be avoided.

Normally, the highway lighting system for an interchange is to be fed from a load center and shall be controlled by means of a photoelectric control device mounted in the load center. The load center shall conform to the NJDOT Standard Electrical Details. Load centers shall be located above the flood hazard area (100 year flood +25%) design flood elevation.

The designer shall, where feasible, utilize more than one load center at a large interchange to insure that in case of a failure of one load center, the entire interchange shall not be in a total darkness; also, the circuits can be rerouted as desired.

Consecutive lighting shall be connected to alternate circuits to prevent a total blackout of any section of the highway in the event a circuit is out of service.

Each luminaire shall be individually protected by means of a fused connector kit, as indicated on the NJDOT Standard Electrical Details.

Lighting circuits, including the future lighting extensions, where required, shall be designed generally for a maximum of 3% voltage drop at the terminal point of each circuit. It is calculated between the phase and neutral. The lighting circuits shall initially be designed for a maximum of 10 luminaires. For extremely long circuits, where the economy of installation warrants it, the maximum voltage drop may exceed 3% and the maximum load may be increased. However, the Bureau of Traffic Engineering must approve the design.

All lighting circuits shall be balanced.

Lighting circuits shall be so arranged that in case of failure in one of the circuits, it shall be possible to reroute the failed circuit with minimum work. In order to accomplish this flexibility in the circuitry, an empty conduit shall be provided to connect the conduit systems of adjacent load centers where feasible.

At all mainline highway crossings, a spare conduit shall be provided.

On all highways where imminent widening is contemplated, the locations of the lighting system shall be outside the limits of the future widening.

The system shall be designed so that the permanent lighting installations shall be completed and in operation when a new highway is opened to traffic. If this cannot be accomplished, temporary lighting shall be provided.

11.4 Sign Lighting

The following guidelines shall be used by the Traffic Designer to determine if sign lighting is to be provided for Overhead Signs, Type GO and GOX:

- A. The tangent sight distance is less than 1200 feet due to horizontal or vertical curve or other sight obstructions.
- B. Geographic and/or geometric conditions may warrant sign lighting for the following situations and an evaluation shall be made:
 - Diagrammatic signs
 - "Exit Only" lane drops
 - High volume interchange (interstate to interstate)
 - Areas with high concentration of dew, fog or frost
 - Sheeting material retroreflectivity characteristics

When it is determined that overhead sign lighting is to be provided, the lighting level shall conform to the following design parameters:

- The light loss factor for mercury vapor type is 1.00

- The light loss factor for metal halide type is 0.72
- The maximum-to-minimum uniformity ratio 6:1 or better
- The average maintained illuminance values as outlined in the AASHTO Roadway Lighting Design Guide

Sign lighting luminaires shall be a 250 watt mercury vapor luminaire conforming to the current NJDOT Specification No. EB-SL-1, or Pulse Start 150 watt metal halide fixtures. Typical installations are included in the NJDOT Standard Electrical Details. The designer shall coordinate the electrical details and the details of the sign structure.

Where sign lighting is not required, walkways and luminaire supports are not to be provided, but the design of the sign structure shall allow for the future installation of walkways and luminaire supports.

11.5 Existing Highway Lighting System

When an existing lighting system is being affected by construction and the light source is other than high pressure sodium, it shall be converted to high pressure sodium.

11.6 Temporary Lighting

During various stages of construction, temporary lighting shall be provided for a section of highway that is opened to traffic and has any of the following conditions:

- The existing lighting system, either utility pole lighting system or State lighting system, is being interrupted.
- An acute change in the highway geometry and/or traveled lane(s).
- Designer shall indicate on either the Traffic Control Plan, Stage Construction sheets or with separate plan sheets, the areas where temporary highway lighting is required.

11.6.1 Designing the Temporary Lighting

Temporary lighting design is concerned with the duration and location of the lighting units, so as to provide the illuminance values as outlined in section 11.3 with a uniformity of 3:1 to 4:1. Provide a safe temporary lighting system that conforms to the publications listed in Section 11.2 with considerations to the following:

- Investigate the possibility of installing certain proposed lighting systems, including underground facilities in the early stage of construction and utilize them as the temporary lighting.
- The use of galvanized steel, helix screw type foundations.
- The use of wood poles.

Regardless of what type of temporary lighting facilities, the contractor shall maintain the installations, until they are no longer required and then remove the portions that are not part of the permanent lighting system.

11.7 Highway Lighting Plans

A sample lighting plan, sheet E-1, is available as part of the NJDOT Sample Plans.

Provide a Highway Lighting Key Sheet which includes the placement of the lighting system equipment.

11.8 Lighting at Intersections

All signalized intersections are to be illuminated.

Non-signalized Major intersections must meet one of the criteria as outlined below:

- Four lane highway.
- Warrants (dusk to dawn):
 1. Any right turn movement on to the highway greater than 75 VPH.
 2. Any left turn movement on to the highway greater than 25 VPH/Leg.
 3. Through movement for the intersecting roadway greater than 50 VPH in either leg.

The VPH warrants for lighting depicted on these figures are based on the highest VPH count in a given nighttime hour.

- If lighting is warranted based on the above warrants, then the need for lighting at a particular intersection must be considered utilizing evaluation Form 7 (Lighting Form 7) or Form 8 (Lighting Form 8) appropriately.
- Design Criteria for Intersection Lighting:

Lighting levels shall be 0.6 footcandle to 1.2 footcandle.

1. Design for a uniformity of illuminance on the highway that shall produce a uniformity ratio of 3:1 to 4:1 or better with a 0.2 footcandle minimum level. The ratio is defined as the average to minimum illuminance.
2. Typical area of illumination shall be as shown in Figures 11-B and 11-C.
3. At signalized intersections lighting shall be installed on traffic signal standards wherever possible if minimum utility clearances allow. Refer to Section 11.3.2.
4. 150 watt luminaires shall be used.

11.9 Non-Functional Historic Replica Lighting

In special historical areas where it is desirable to construct "Streetscape" type projects. The luminaries shall have a lens without prisms and a low wattage HPS SON lamp mounted at a height not to exceed 12 feet. The level of illuminance on the highway shall not exceed 0.2 footcandle.

A plan, with isolux lines, of the project area shall be submitted to the Bureau of Traffic Engineering for approval.

11.10 Functional Historic Lighting

In special State Historic Preservation Office (SHPO) designated areas, it may be desirable to utilize luminaries/standards other than those described elsewhere in this Section. The following guidelines shall apply:

- The designer shall submit the proposed design as per 11.3.6 to the Bureau of Traffic Engineering.
- The design shall conform to all other requirements of this section.
- Lighting standards, arms and luminaires mounted on top of parapets may be special nonstandard types.

- Lighting standards are mounted at grade. The standard may be anodized a color compatible with the area design scheme.
- The arm may be a special type, but must be capable of mounting on a Department lighting standard.
- The designer shall meet with the in the Bureau of Traffic Engineering prior to beginning the design.

11.11 Mid-Block Pedestrian Crossing

Special considerations must be given to provide proper lighting within the designated crosswalk areas. Since these crossings are not at intersections, higher illuminance values than the standard roadway levels are required. Minimum average maintained illuminance within the crosswalk area shall be between 1.2 footcandles and 2.0 footcandles. Luminaires shall be placed approximately 10 ft. prior to the edge of the crosswalk in the direction of travel.

Higher values may be required depending upon the level of night time pedestrian activity and design circumstances, but must be approved in writing by NJDOT.

11.12 Roundabout Lighting

Lighting must conform to the current IES-DG-19-08 design guide for roundabout lighting. Preliminary plans of the lighting layout must be submitted to the Bureau of Traffic Engineering for review and approval.

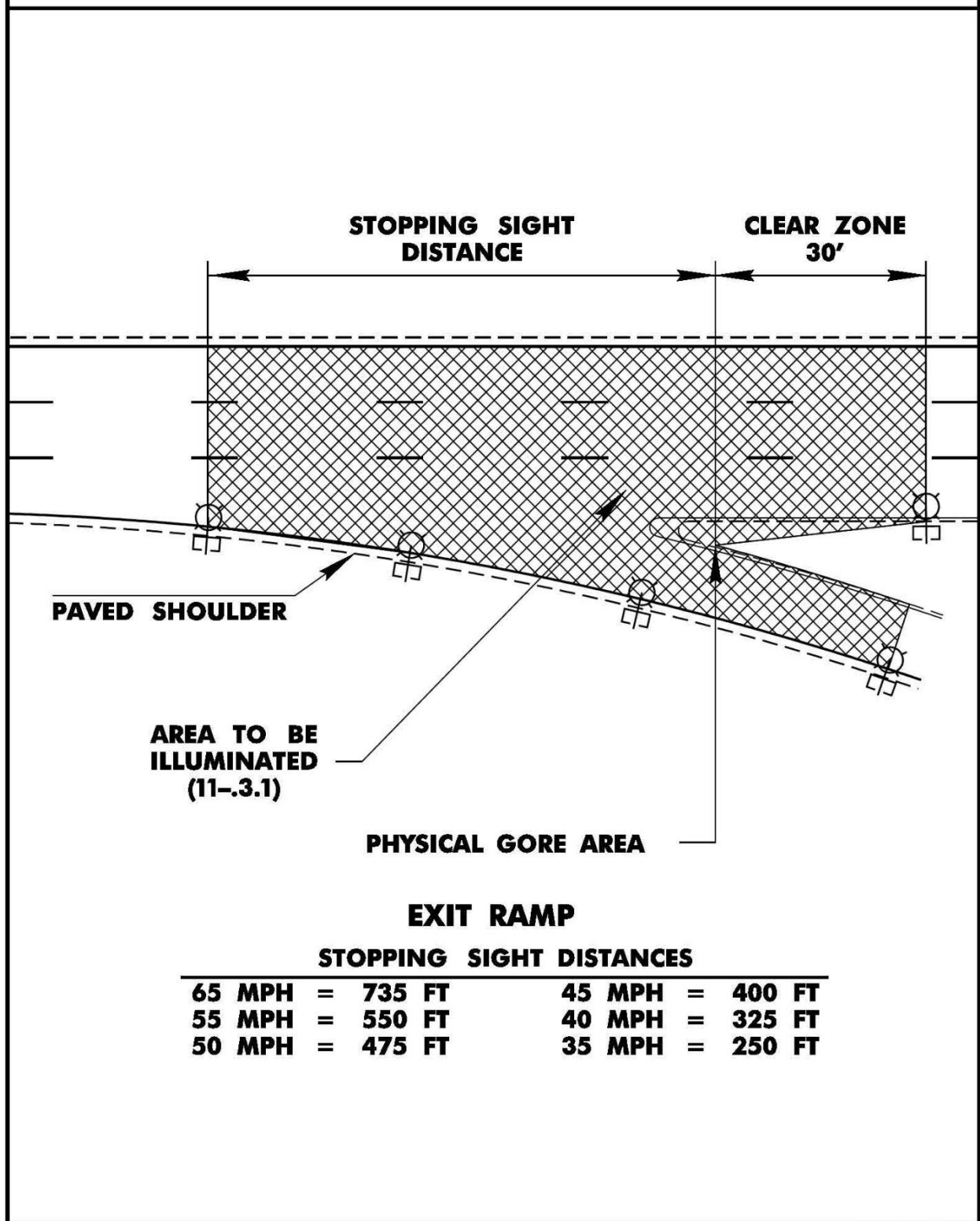
11.13 Pedestrian Crosswalks

Investigate the need for crosswalk illumination. If illumination is needed, design values shall be 0.6 to 0.8 minimum footcandles.

11.14 Light Trespass from Off-Site Development

Spillover lighting from Business or Developmental Projects adjacent to State highways shall not exceed 0.2 fc at the curblines of the highway. A lighting plan of the project site, depicting the photometric values on the State roadway, shall be submitted to the Bureau of Traffic Engineering for review and approval.

**FIGURE 11-A:
FREEWAYS MINIMUM LIGHTING STANDARDS**



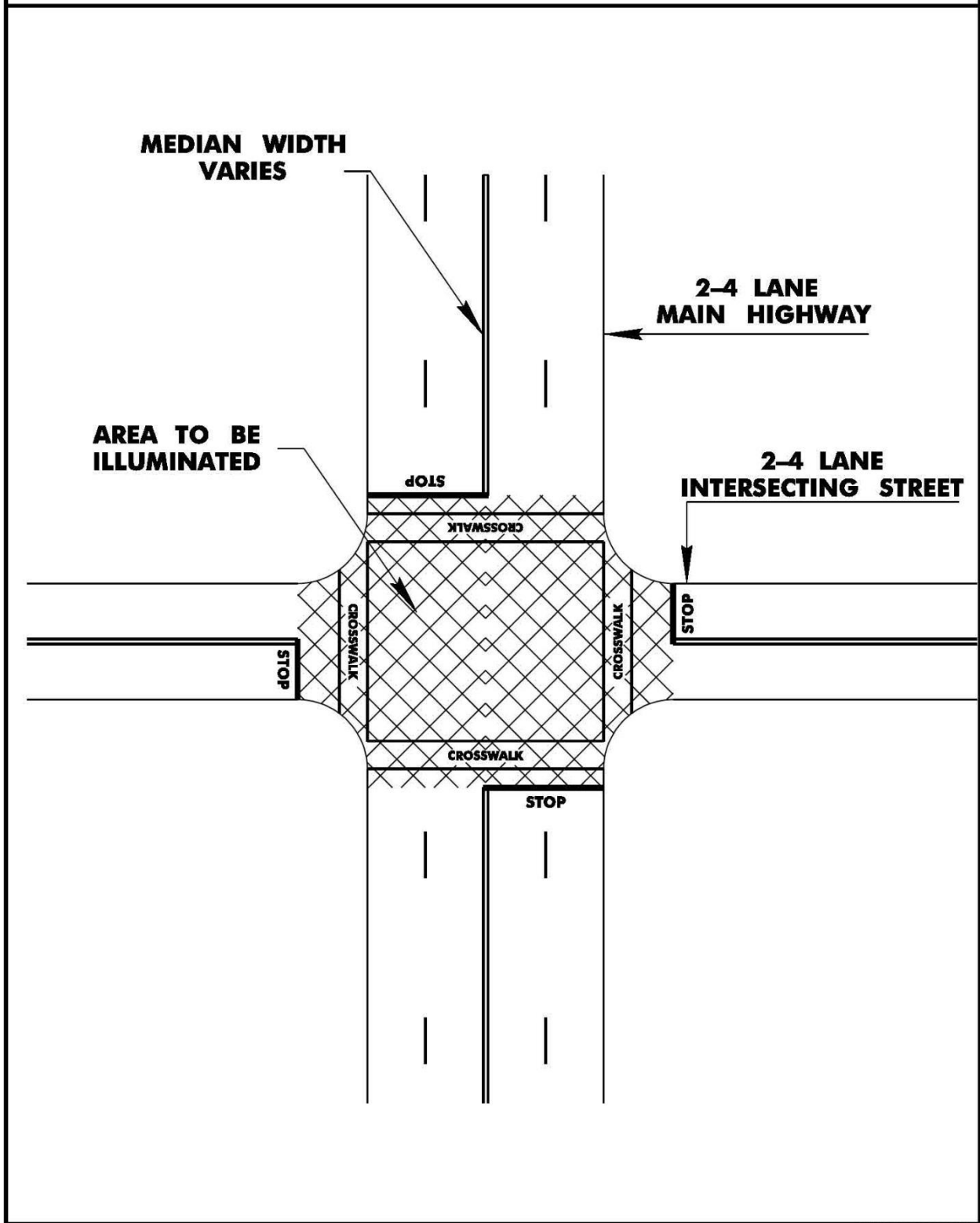
EXIT RAMP

STOPPING SIGHT DISTANCES

65 MPH = 735 FT	45 MPH = 400 FT
55 MPH = 550 FT	40 MPH = 325 FT
50 MPH = 475 FT	35 MPH = 250 FT

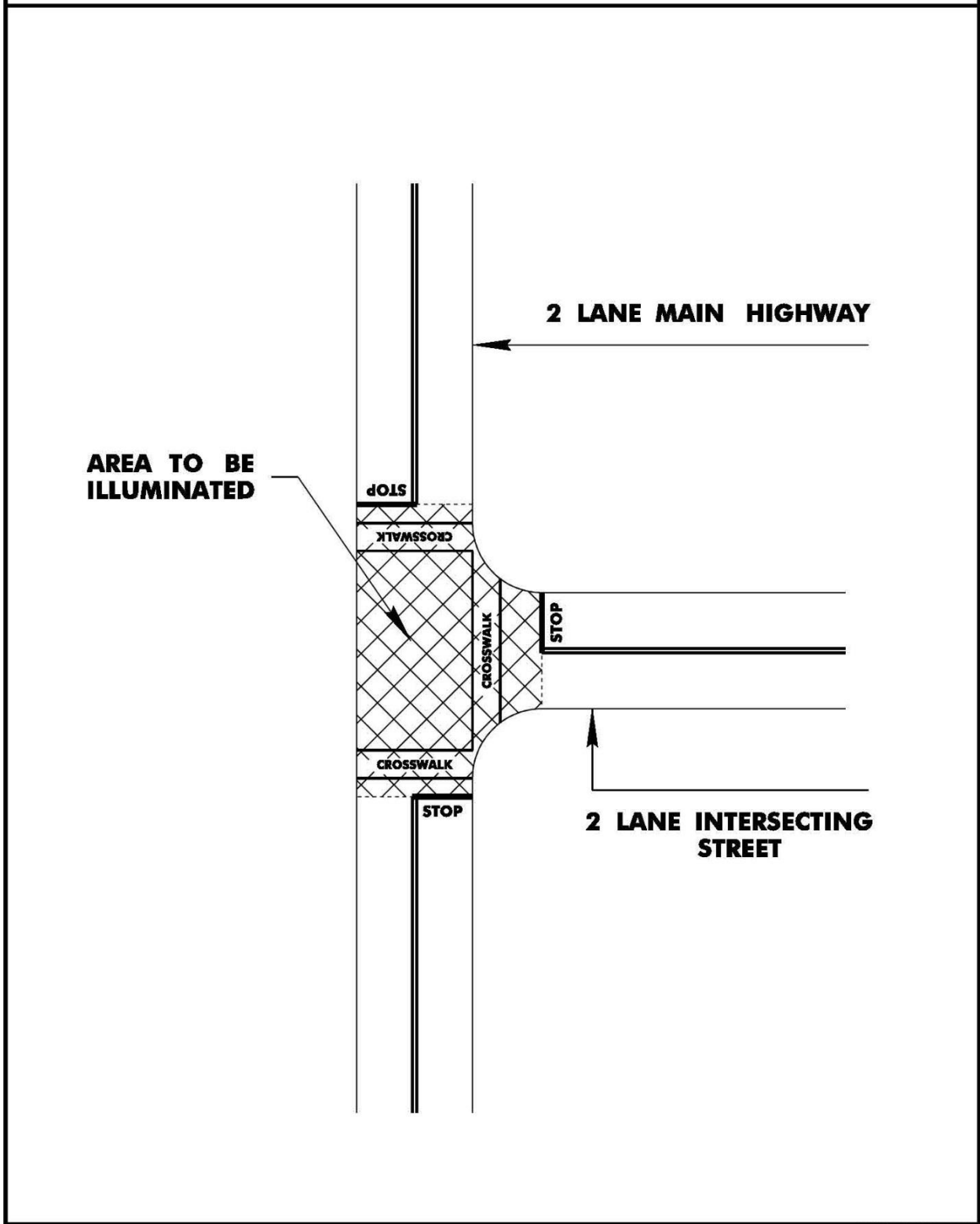
REV. DATE: JUNE 30, 2016

**FIGURE 11-B:
NON-CONTROLLED ACCESS (LAND SERVICE) HIGHWAYS MINIMUM
LIGHTING STANDARDS SIGNALIZED OR NON-SIGNALIZED INTERSECTION**



REV. DATE: JUNE '80, 2016

**FIGURE 11-C:
NON-CONTROLLED ACCESS (LAND SERVICE) HIGHWAYS MINIMUM LIGHTING
STANDARDS SIGNALIZED OR NON-SIGNALIZED "T" INTERSECTION**



REV. DATE: JUNE 30, 2016

EVALUATION FORM FOR CONTROLLED ACCESS FACILITY (CONTINUOUS FREEWAY LIGHTING)							LIGHTING FORM 1		
CLASSIFICATION FACTOR	RATING					UNLIT WEIGHT (A)	LIGHTED WEIGHT (B)	DIFF (A-B)	RATING X(A-B)
	1	2	3	4	5				
GEOMETRIC FACTORS									
NUMBER OF LANES	4		6		≥8	1.0	0.8	0.2	
LANE WIDTH	>12'	12'	11'	10'	≤9'	3.0	2.5	0.5	
MEDIAN WIDTH	>40'	24'-39'	12'-23'	4'-11'	0-3'	1.0	0.5	0.5	
SHOULDERS	10'	8'	6'	4'	0	1.0	0.5	0.5	
SLOPES	≥8:1	6:1	4:1	3:1	2:1	1.0	0.5	0.5	
CURVES	0-½°	½-1°	1-2°	2-3°	3-4°	13.0	5.0	8.0	
GRADES	<3%	3.0-3.9%	4.0-4.9%	5.0-6.9%	>7%	3.2	2.8	0.4	
INTERCHANGE FREQUENCY	21,000'	16,000'	10,500'	5000'	<5,000'	4.0	1.0	3.0	
						GEOMETRIC TOTAL			
OPERATIONAL FACTORS									
LEVEL OF SERVICE (ANY DARK HOUR)	A	B	C	D	E	6.0	1.0	5.0	
						OPERATIONAL TOTAL			
ENVIRONMENTAL									
% DEVELOPMENT	0%	25%	50%	75%	100%	3.5	0.5	3.0	
OFFSET TO DEVELOPMENT	200'	150'	100'	50'	<50'	3.5	0.5	3.0	
						ENVIRONMENTAL TOTAL			
ACCIDENTS									
RATIO OF NIGHT-TO-DAY ACCIDENTS	1.0	1.0-1.2	1.2-1.5	1.5-2.0	2.0*	10.0	2.0	8.0	
						ACCIDENT TOTAL			
* CONTINUOUS LIGHTING WARRANTED	GEOMETRIC TOTAL = _____ OPERATIONAL TOTAL = _____ ENVIRONMENTAL TOTAL = _____ ACCIDENT TOTAL = _____ SUM = _____ POINTS WARRANTING CONDITION = <u>95</u> POINTS								

EVALUATION FORM FOR INTERCHANGE LIGHTING						LIGHTING FORM 2			
CLASSIFICATION FACTOR	RATING					UNLIT WEIGHT (A)	LIGHTED WEIGHT (B)	DIFF (A-B)	RATING X(A-B)
	1	2	3	4	5				
GEOMETRIC FACTORS									
RAMP TYPES	DIRECT	DIAMOND	BUTTON HOOK CLOVERLEAF	TRUMPET	SCISSOR & LEFTSIDE	2.0	1.0	1.0	
CROSS ROAD CHANNELIZATION	NONE	-----	CONTINUOUS	-----	AT INTERCHANGE INTERSECTION	2.0	1.0	1.0	
FRONTAGE ROADS	NONE	-----	ONE WAY	-----	TWO WAY	1.5	1.0	0.5	
FREEWAY LANE WIDTH	>12'	12'	11'	10'	<10'	3.0	2.5	0.5	
FREEWAY MEDIAN WIDTH	>40'	34'-40'	12'-23'	4'-11'	<4'	1.0	0.5	0.5	
NUMBER OF FREEWAY LANES	≤4	-----	6	-----	≥8	1.0	0.8	0.2	
MAIN LANE CURVES	<½°	1-2°	2-3°	3-4°	>4°	13.0	5.0	8.0	
GRADES	<3%	3.0-3.9%	4.0-4.9%	5.0-6.9%	≥7%	3.2	2.8	0.4	
SIGHT DISTANCE CROSS ROAD INTERSECTION	>1,000'	700'-1,000'	500'-700'	400'-500'	<400'	2.0	1.8	0.2	
						GEOMETRIC TOTAL			
OPERATIONAL FACTORS									
LEVEL OF SERVICE (ANY DARK HOUR)	A	B	C	D	E	6.0	1.0	5.0	
						OPERATIONAL TOTAL			
ENVIRONMENTAL									
% DEVELOPMENT	NONE	1 QUAD	2 QUAD	3 QUAD	4 QUAD	2.0	0.5	1.5	
SET BACK DISTANCE	>200'	150'-200'	100'-150'	50'-100'	<50'	0.5	0.3	0.2	
CROSS ROAD APPROACH LIGHTING	NONE	-----	PARTIAL	-----	COMPLETE	3.0	2.0	1.0	
FREEWAY LIGHTING	NONE	-----	INTERCHANGE ONLY	-----	CONTINUOUS*	5.0	3.0	2.0	
						ENVIRONMENTAL TOTAL			
ACCIDENTS									
RATIO OF NIGHT-TO-DAY ACCIDENTS	<1.0	1.0-1.2	1.2-1.5	1.5-2.0	>2.0*	10.0	2.0	8.0	
						ACCIDENT TOTAL			
* COMPLETE LIGHTING WARRANTED	GEOMETRIC TOTAL = _____ OPERATIONAL TOTAL = _____ ENVIRONMENTAL TOTAL = _____ ACCIDENT TOTAL = _____ SUM = _____ POINTS COMPLETE LIGHTING WARRANTING CONDITION = <u>90 POINTS</u> PARTIAL LIGHTING WARRANTING CONDITION = <u>60 POINTS</u>								

EVALUATION FORM FOR CONTROLLED ACCESS FACILITY (NEW ROADWAY/ALIGNMENT)							LIGHTING FORM 3		
CLASSIFICATION FACTOR	RATING					UNLIT WEIGHT (A)	LIGHTED WEIGHT (B)	DIFF (A-B)	RATING X(A-B)
	1	2	3	4	5				
GEOMETRIC FACTORS									
NUMBER OF LANES	4		6		≥8	1.0	0.8	0.2	
LANE WIDTH	>12'	12'	11'	10'	≤9'	3.0	2.5	0.5	
MEDIAN WIDTH	>40'	24'-39'	12'-23'	4'-11'	0-3'	1.0	0.5	0.5	
SHOULDERS	10'	8'	6'	4'	0	1.0	0.5	0.5	
SLOPES	≥8:1	6:1	4:1	3:1	2:1	1.0	0.5	0.5	
CURVES	0-½°	½-1°	1-2°	2-3°	3-4°	13.0	5.0	8.0	
GRADES	<3%	3.0-3.9%	4.0-4.9%	5.0-6.9%	>7%	3.2	2.8	0.4	
INTERCHANGE FREQUENCY	21,000'	16,000'	10,500'	5,000'	<5,000'	4.0	1.0	3.0	
						GEOMETRIC TOTAL			
OPERATIONAL FACTORS									
LEVEL OF SERVICE (ANY DARK HOUR)	A	B	C	D	E	6.0	1.0	5.0	
						OPERATIONAL TOTAL			
ENVIRONMENTAL									
% DEVELOPMENT	0%	25%	50%	75%	100%	3.5	0.5	3.0	
OFFSET TO DEVELOPMENT	200'	150'	100'	50'	<50'	3.5	0.5	3.0	
						ENVIRONMENTAL TOTAL			
	GEOMETRIC TOTAL = _____ OPERATIONAL TOTAL = _____ ENVIRONMENTAL = _____ TOTAL = _____ POINTS SUM = <u>70</u> POINTS WARRANTING CONDITION								

EVALUATION FORM FOR INTERCHANGE LIGHTING (NEW ALIGNMENT)							LIGHTING FORM 4		
CLASSIFICATION FACTOR	RATING					UNLIT WEIGHT (A)	LIGHTED WEIGHT (B)	DIFF (A-B)	RATING X(A-B)
	1	2	3	4	5				
GEOMETRIC FACTORS									
RAMP TYPES	DIRECT	DIAMOND	BUTTON HOOK CLOVERLEAF	TRUMPET	SCISSOR & LEFTSIDE	2.0	1.0	1.0	
CROSS ROAD CHANNELIZATION	NONE	-----	CONTINUOUS	-----	AT INTERCHANGE INTERSECTION	2.0	1.0	1.0	
FRONTAGE ROADS	NONE	-----	ONE WAY	-----	TWO WAY	1.5	1.0	0.5	
FREEWAY LANE WIDTH	>12'	12'	11'	10'	<10'	3.0	2.5	0.5	
FREEWAY MEDIAN WIDTH	>40'	34'-40'	12'-23'	4'-11'	<4'	1.0	0.5	0.5	
NUMBER OF FREEWAY LANES	≤4	-----	6	-----	≥8	1.0	0.8	0.2	
MAIN LANE CURVES	<½°	1-2°	2-3°	3-4°	>4°	13.0	5.0	8.0	
GRADES	<3%	3.0-3.9%	4.0-4.9%	5.0-6.9%	≥7%	3.2	2.8	0.4	
SIGHT DISTANCE CROSS ROAD INTERSECTION	>1,000'	700'-1,000'	500'-700'	400'-500'	<400'	2.0	1.8	0.2	
						GEOMETRIC TOTAL			
OPERATIONAL FACTORS									
LEVEL OF SERVICE (ANY DARK HOUR)	A	B	C	D	E	6.0	1.0	5.0	
						OPERATIONAL TOTAL			
ENVIRONMENTAL									
% DEVELOPMENT	NONE	1 QUAD	2 QUAD	3 QUAD	4 QUAD	2.0	0.5	1.5	
SET BACK DISTANCE	>200'	150'-200'	100'-150'	50'-100'	<50'	0.5	0.3	0.2	
CROSS ROAD APPROACH LIGHTING	NONE	-----	PARTIAL	-----	COMPLETE	3.0	2.0	1.0	
FREEWAY LIGHTING	NONE	-----	INTERCHANGE ONLY	-----	CONTINUOUS*	5.0	3.0	2.0	
						ENVIRONMENTAL TOTAL			
* COMPLETE LIGHTING WARRANTED	GEOMETRIC TOTAL = _____ OPERATIONAL TOTAL = _____ ENVIRONMENTAL TOTAL = _____ SUM = _____ POINTS COMPLETE LIGHTING WARRANTING CONDITION = <u>65</u> POINTS PARTIAL LIGHTING WARRANTING CONDITION = <u>35</u> POINTS								

EVALUATION FORM FOR NON-CONTROLLED ACCESS FACILITY LIGHTING								LIGHTING FORM 5	
CLASSIFICATION FACTOR	RATING					UNLIT WEIGHT (A)	LIGHTED WEIGHT (B)	DIFF (A-B)	RATING X(A-B)
	1	2	3	4	5				
GEOMETRIC									
NUMBER OF LANES	≤4	-----	6	-----	≥8	1.0	0.8	0.2	
LANE WIDTH	>12'	12'	11'	10'	<10'	3.0	2.5	0.5	
MEDIAN OPENING PER MILE	<4 OR ONE WAY	4.0-8.0	8.1-12.0	12.1-15.0	>15 OR NO ACCESS	5.0	3.0	2.0	
CURB CUTS	<10%	10-20%	20-30%	30-40%	>40%	5.0	3.0	2.0	
CURVES	<3.0°	3.1-6.0°	6.1-8.0°	8.1-10.0°	>10°	13.0	5.0	8.0	
GRADES	<3%	3.0-3.9%	4.0-4.9%	5.0-6.9%	>7.0%	3.2	2.8	0.4	
SIGHT DISTANCE	>700'	500'-700'	300'-500'	200'-300'	<200'	2.0	1.8	0.2	
PARKING	PROHIBITED BOTH SIDES	LOADING ZONE ONLY	OFF PEAK ONLY	PERMITTED ONE SIDE	PERMITTED BOTH SIDES	0.2	0.1	0.1	
						GEOMETRIC TOTAL			
OPERATIONAL									
SIGNALS	ALL MAJOR INTERSECTIONS	MAJORITY OF INTERSECTIONS	MOST MAJOR INTERSECTIONS	½ THE INTERSECTIONS	FREQUENT NON-SIGNALIZED INTERSECTIONS	3.0	2.8	0.2	
LEFT TURN LANE	ALL MAJOR INTERSECTIONS OR ONE WAY	MAJORITY OF INTERSECTIONS	MOST MAJOR INTERSECTIONS	½ MAJOR INTERSECTIONS	INFREQUENT OR UNDIVIDED STREET	5.0	4.0	1.0	
MEDIAN WIDTH	30'	20'-30'	10'-20'	4'-10'	0-4'	1.0	0.5	0.5	
SPEED LIMIT	≤25	30	35	40	≥45	1.0	0.2	0.8	
NIGHT PEDESTRIAN TRAFFIC (PEDS/KM)	FEW OR NONE	0-50	50-100	100-200	>200	1.5	0.5	1.0	
						OPERATIONAL TOTAL			
ENVIRONMENTAL									
% DEVELOPMENT	0%	0-30%	30-60%	60-90%	100%	0.5	0.3	0.2	
TYPE OF DEVELOPMENT	UNDEVELOPED	RESIDENTIAL	½ RESIDENTIAL AND/OR COMMERCIAL	INDUSTRIAL OR COMMERCIAL	STRIP INDUSTRY OR COMMERCIAL	0.5	0.3	0.2	
SET BACK DISTANCE	>200'	150'-200'	100'-150'	50'-100'	<50'	0.5	0.3	0.2	
ADVERTISING/AREA LIGHTING	NONE	0-40%	41-60%	61-80%	CONTINUOUS	3.0	1.0	2.0	
RAISED CURB MEDIAN	NONE	CONTINUOUS	AT ALL INTERSECTIONS	ALL SIGNALIZED INTERSECTIONS	FEW LOCATIONS	1.0	0.5	0.5	
CRIME RATE	EXTREMELY LOW	LOWER THAN CITY AVERAGE	CITY AVERAGE	HIGHER THAN CITY AVERAGE	EXTREMELY HIGH	1.0	0.5	0.5	
						ENVIRONMENTAL TOTAL			
ACCIDENTS									
RATIO OF NIGHT-TO-DAY ACCIDENTS	<1.0	1.0-1.2	1.2-1.5	1.5-2.0	>2.0*	10.0	2.0	8.0	
						ACCIDENT TOTAL			
* CONTINUOUS LIGHTING WARRANTED		GEOMETRIC TOTAL				= _____			
		OPERATIONAL TOTAL				= _____			
		ENVIRONMENTAL TOTAL				= _____			
		ACCIDENT TOTAL				= _____			
		SUM				= _____	POINTS		
WARRANTING CONDITION				= _____	85 POINTS				

EVALUATION FORM FOR NON-CONTROLLED ACCESS FACILITY LIGHTING (NEW ALIGNMENT)								LIGHTING FORM 6	
CLASSIFICATION FACTOR	RATING					UNLIT WEIGHT (A)	LIGHTED WEIGHT (B)	DIFF (A-B)	RATING X(A-B)
	1	2	3	4	5				
GEOMETRIC									
NUMBER OF LANES	≤4	-----	6	-----	≥8	1.0	0.8	0.2	
LANE WIDTH	>12'	12'	11'	10'	<10'	3.0	2.5	0.5	
MEDIAN OPENING PER MILE	<4 OR ONE WAY	4.0-8.0	8.1-12.0	12.1-15.0	>15 OR NO ACCESS	5.0	3.0	2.0	
CURB CUTS	<10%	10-20%	20-30%	30-40%	>40%	5.0	3.0	2.0	
CURVES	<3.0°	3.1-6.0°	6.1-8.0°	8.1-10.0°	>10°	13.0	5.0	8.0	
GRADES	<3%	3.0-3.9%	4.0-4.9%	5.0-6.9%	>7.0%	3.2	2.8	0.4	
SIGHT DISTANCE	>700'	500'-700'	300'-500'	200'-300'	<200'	2.0	1.8	0.2	
PARKING	PROHIBITED BOTH SIDES	LOADING ZONE ONLY	OFF PEAK ONLY	PERMITTED ONE SIDE	PERMITTED BOTH SIDES	0.2	0.1	0.1	
						GEOMETRIC TOTAL			
OPERATIONAL									
SIGNALS	ALL MAJOR INTERSECTIONS	MAJORITY OF INTERSECTIONS	MOST MAJOR INTERSECTIONS	½ THE INTERSECTIONS	FREQUENT NON-SIGNALIZED INTERSECTIONS	3.0	2.8	0.2	
LEFT TURN LANE	ALL MAJOR INTERSECTIONS OR ONE WAY	MAJORITY OF INTERSECTIONS	MOST MAJOR INTERSECTIONS	½ MAJOR INTERSECTIONS	INFREQUENT OR UNDIVIDED STREET	5.0	4.0	1.0	
MEDIAN WIDTH	30'	20'-30'	10'-20'	4'-10'	0-4'	1.0	0.5	0.5	
SPEED LIMIT	≤25	30	35	40	≥45	1.0	0.2	0.8	
NIGHT PEDESTRIAN TRAFFIC (PEDS/KM)	FEW OR NONE	0-50	50-100	100-200	>200	1.5	0.5	1.0	
						OPERATIONAL TOTAL			
ENVIRONMENTAL									
% DEVELOPMENT	0%	0-30%	30-60%	60-90%	100%	0.5	0.3	0.2	
TYPE OF DEVELOPMENT	UNDEVELOPED	RESIDENTIAL	½ RESIDENTIAL AND/OR COMMERCIAL	INDUSTRIAL OR COMMERCIAL	STRIP INDUSTRY OR COMMERCIAL	0.5	0.3	0.2	
SET BACK DISTANCE	>200'	150'-200'	100'-150'	50'-100'	<50'	0.5	0.3	0.2	
ADVERTISING/AREA LIGHTING	NONE	0-40%	41-60%	61-80%	CONTINUOUS	3.0	1.0	2.0	
RAISED CURB MEDIAN	NONE	CONTINUOUS	AT ALL INTERSECTIONS	ALL SIGNALIZED INTERSECTIONS	FEW LOCATIONS	1.0	0.5	0.5	
CRIME RATE	EXTREMELY LOW	LOWER THAN CITY AVERAGE	CITY AVERAGE	HIGHER THAN CITY AVERAGE	EXTREMELY HIGH	1.0	0.5	0.5	
						ENVIRONMENTAL TOTAL			
GEOMETRIC TOTAL OPERATIONAL TOTAL ENVIRONMENTAL TOTAL SUM WARRANTING CONDITION						_____ _____ _____ _____ _____ POINTS _____ 60 POINTS			

EVALUATION FORM FOR INTERSECTION LIGHTING						LIGHTING FORM 7				
CLASSIFICATION FACTOR	RATING					UNLIT WEIGHT (A)	LIGHTED WEIGHT (B)	DIFF (A-B)	RATING X(A-B)	
	1	2	3	4	5					
GEOMETRIC										
NUMBER OF LEGS	-----	3	4	5	≥6 INCL TRAFFIC CIRCLE	3.0	2.5	0.5		
APPROACH LANE WIDTH	>12'	12'	11'	10'	<10'	3.0	2.5	0.5		
CHANNELIZATION	NO TURN LANES	LEFT TURN ON MAJOR LEG	LEFT TURN ALL LEGS-RIGHT TURN ON MAJOR LEGS	LEFT AND RIGHT TURN ON MAJOR LEGS	LEFT AND RIGHT TURN ON ALL LEGS	2.0	1.0	1.0		
CURVATURE ON APPROACH LEGS	<3.0°	3.1-6.0°	6.1-8.0°	8.1-10.0°	>10°	13.0	5.0	8.0		
GRADES ON APPROACH	<3%	3.0-3.9%	4.0-4.9%	5.0-6.9%	>7.0%	3.2	2.8	0.4		
APPROACH SIGHT DISTANCE	>700'	500'-700'	300'-500'	200'-300'	<200'	2.0	1.8	0.2		
PARKING	PROHIBITED BOTH SIDES	LOADING ZONE ONLY	OFF PEAK ONLY	PERMITTED ONE SIDE	PERMITTED BOTH SIDES	0.2	0.1	0.1		
						GEOMETRIC TOTAL				
OPERATIONAL										
TYPE OF CONTROL	ALL PHASES SIGNALIZED (INCL TURN LANE)	LEFT TURN LANE SIGNAL CONTROL	THRU TRAFFIC SIGNAL CONTROL ONLY	4-WAY STOP CONTROL	STOP CONTROL TO MINOR LEG OR NO CONTROL	3.0	2.7	0.3		
CHANNELIZATION	LEFT AND RIGHT SIGNAL CONTROL	LEFT AND RIGHT TURN LANE SIGNAL CONTROL MAJOR LEG	LEFT TURN LANE SIGNAL CONTROL ALL LEGS	LEFT TURN LANE SIGNAL CONTROL MAJOR LEG	NO TURN LANE CONTROL	3.0	2.0	1.0		
LEVEL OF SERVICE (LOAD FACTOR)	A 0	B 0-0.1	C 0.1-0.3	D 0.3-0.7	E 0.7-1.0	1.0	0.2	0.8		
SPEED LIMIT ON APPROACH LEGS	≤25	30	35	40	≥45	1.0	0.2	0.8		
NIGHT PEDESTRIAN TRAFFIC (PEDS/KM)	FEW OR NONE	0-50	50-100	100-200	>200	1.5	0.5	1.0		
						OPERATIONAL TOTAL				
ENVIRONMENTAL										
% DEVELOPMENT	0%	0-30%	30-60%	60-90%	100%	0.5	0.3	0.2		
TYPE OF DEVELOPMENT NEAR INTERSECTION	UNDEVELOPED	RESIDENTIAL	½ RESIDENTIAL AND/OR COMMERCIAL	INDUSTRIAL OR COMMERCIAL	STRIP INDUSTRY OR COMMERCIAL	0.5	0.3	0.2		
LIGHTING IN IMMEDIATE VICINITY	NONE	0-40%	41-60%	61-80%	CONTINUOUS	3.0	1.5	1.5		
CRIME RATE	EXTREMELY LOW	LOWER THAN CITY AVERAGE	CITY AVERAGE	HIGHER THAN CITY AVERAGE	EXTREMELY HIGH	1.0	0.5	0.5		
						ENVIRONMENTAL TOTAL				
ACCIDENTS										
RATIO OF NIGHT-TO-DAY ACCIDENTS	<1.0	1.0-1.2	1.2-1.5	1.5-2.0	>2.0*	10.0	2.0	8.0		
						ACCIDENT TOTAL				
* CONTINUOUS LIGHTING WARRANTED		GEOMETRIC TOTAL				= _____				
		OPERATIONAL TOTAL				= _____				
		ENVIRONMENTAL TOTAL				= _____				
		ACCIDENT TOTAL				= _____				
		SUM				= _____	POINTS			
WARRANTING CONDITION				= _____	75 POINTS					

EVALUATION FORM FOR INTERSECTION LIGHTING (NEW ROADWAY/ALIGNMENT)							LIGHTING FORM 8		
CLASSIFICATION FACTOR	RATING					UNLIT WEIGHT (A)	LIGHTED WEIGHT (B)	DIFF (A-B)	RATING X(A-B)
	1	2	3	4	5				
GEOMETRIC									
NUMBER OF LEGS	----	3	4	5	≥6 INCL TRAFFIC CIRCLE	3.0	2.5	0.5	
APPROACH LANE WIDTH	>12'	12'	11'	10'	<10'	3.0	2.5	0.5	
CHANNELIZATION	NO TURN LANES	LEFT TURN ON MAJOR LEG	LEFT TURN ALL LEGS-RIGHT TURN ON MAJOR LEGS	LEFT AND RIGHT TURN ON MAJOR LEGS	LEFT AND RIGHT TURN ON ALL LEGS	2.0	1.0	1.0	
CURVATURE ON APPROACH LEGS	<3.0°	3.1-6.0°	6.1-8.0°	8.1-10.0°	>10°	13.0	5.0	8.0	
GRADES ON APPROACH	<3%	3.0-3.9%	4.0-4.9%	5.0-6.9%	>7.0%	3.2	2.8	0.4	
APPROACH SIGHT DISTANCE	>700'	500'-700'	300'-500'	200'-300'	<200'	2.0	1.8	0.2	
PARKING	PROHIBITED BOTH SIDES	LOADING ZONE ONLY	OFF PEAK ONLY	PERMITTED ONE SIDE	PERMITTED BOTH SIDES	0.2	0.1	0.1	
						GEOMETRIC TOTAL			
OPERATIONAL									
TYPE OF CONTROL	ALL PHASES SIGNALIZED (INCL TURN LANE)	LEFT TURN LANE SIGNAL CONTROL	THRU TRAFFIC SIGNAL CONTROL ONLY	4-WAY STOP CONTROL	STOP CONTROL TO MINOR LEG OR NO CONTROL	3.0	2.7	0.3	
CHANNELIZATION	LEFT AND RIGHT SIGNAL CONTROL	LEFT AND RIGHT TURN LANE SIGNAL CONTROL MAJOR LEG	LEFT TURN LANE SIGNAL CONTROL ALL LEGS	LEFT TURN LANE SIGNAL CONTROL MAJOR LEG	NO TURN LANE CONTROL	3.0	2.0	1.0	
LEVEL OF SERVICE (LOAD FACTOR)	A 0	B 0-0.1	C 0.1-0.3	D 0.3-0.7	E 0.7-1.0	1.0	0.2	0.8	
SPEED LIMIT ON APPROACH LEGS	≤25	30	35	40	≥45	1.0	0.2	0.8	
NIGHT PEDESTRIAN TRAFFIC (PEDS/KM)	FEW OR NONE	0-50	50-100	100-200	>200	1.5	0.5	1.0	
						OPERATIONAL TOTAL			
ENVIRONMENTAL									
% DEVELOPMENT	0%	0-30%	30-60%	60-90%	100%	0.5	0.3	0.2	
TYPE OF DEVELOPMENT NEAR INTERSECTION	UNDEVELOPED	RESIDENTIAL	½ RESIDENTIAL AND/OR COMMERCIAL	INDUSTRIAL OR COMMERCIAL	STRIP INDUSTRY OR COMMERCIAL	0.5	0.3	0.2	
LIGHTING IN IMMEDIATE VICINITY	NONE	0-40%	41-60%	61-80%	CONTINUOUS	3.0	1.5	1.5	
CRIME RATE	EXTREMELY LOW	LOWER THAN CITY AVERAGE	CITY AVERAGE	HIGHER THAN CITY AVERAGE	EXTREMELY HIGH	1.0	0.5	0.5	
						ENVIRONMENTAL TOTAL			
GEOMETRIC TOTAL = _____ OPERATIONAL TOTAL = _____ ENVIRONMENTAL TOTAL = _____ SUM = _____ POINTS WARRANTING CONDITION = 50 POINTS									

11.15 Voltage Drop Calculation Method

The total voltage drop in a highway lighting circuit is calculated by solving for the voltage drop in each branch of the circuit. In a simple circuit, the voltage drop in each section of a circuit is equal to the total current flowing in the section multiplied by the total impedance of the wire used in the section. The total voltage drop in each branch may not exceed 3%. Expressing this in equation form yields:

(V)		(I)		(Z)
Voltage Drop In Each Section	=	Current In Each Section	*	Impedance of Each Section

The current (I) flowing in each section is equal to the sum of the currents drawn by the luminaires in the circuit behind the section. The total impedance (Z) of a section is equal to the impedance of the cable in that section (including the neutral wire).

Voltage Drop Calculation Sample

Circuit voltage is 240 volts.

Luminaires #1 and #5 are 150 watt HPS (0.9 A each).

Luminaire #3 is 250 watt HPS (1.4 A each).

Wire size is # 2 AWG (0.20 ohms/1,000 feet).

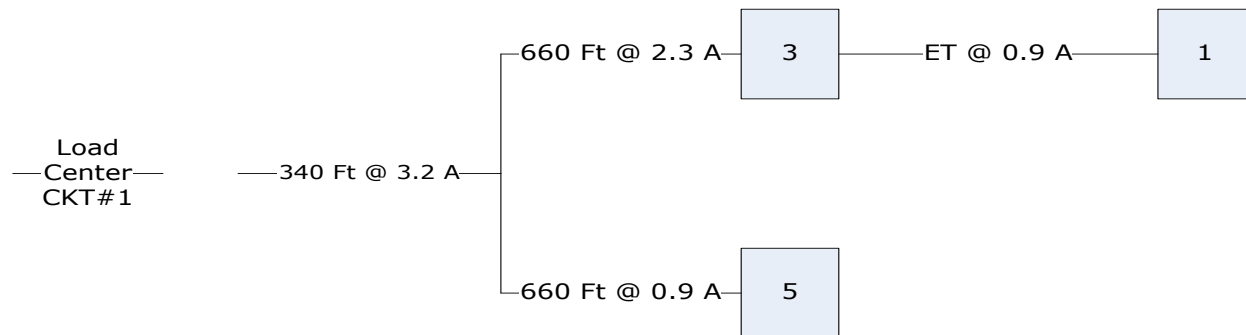
Section No.	From	To	(I) Current (Amps)	Length Of Wire (Feet)	(Z) Impedance (Ohms)	(V) Voltage Drop (Volts)
Branch "A"						
1	L.C.	# 3	2.3	(1,000') 2	(2,000')(.001)(.20)	0.92
2	# 3	# 1	0.9	(500') 2	(1,000')(.001)(.20)	0.18
Branch "B"						
1	L.C.	# 5	0.9	(1,000') 2	(2,000')(.001)(.20)	0.36

Total Voltage Drop of Branch "A" = (0.92 v) + (0.18 v) = 1.10 volts

Percent Voltage Drop of Branch "A" = (1.10 v) / (240 v) * 100 % = 0.46 %

Percent Voltage Drop of Branch "B" = (0.36 v) / (240 v) * 100 % = 0.15 %

Sketch Sample



Voltage Drop Calculation Form

Project: _____.

Load Center: _____ Circuit Designation: _____.

Number Of Lamps (Total): _____ Total Load: _____ Amps

Lamp Types & Quantity: _____

Lamp Numbers: _____.

Wire Size (AWG)	Resistance Per 1,000 Feet
# 8	0.78 ohms
# 6	0.49 ohms
# 4	0.31 ohms
# 2	0.20 ohms
# 1/0	0.12 ohms

Lamp Type	Lamp Current Including Ballast At 240 Volts
150 W HPS	0.9 / 1.5 amps
250 W HPS	1.3 amps
400 W HPS	2.0 amps
250 W MV	1.3 amps

Wire Size Used: _____

Number Of Branches: _____

SECTION NO.	FROM	TO	(I) Current (amps)	Length of Wire (feet)	(Z) Impedance (ohms)	(V) Voltage Drop (volts)

Total Voltage Drop Of Branch "A" = _____ Volts

Percent Voltage Drop Of Branch "A" = _____

Total Voltage Drop Of Branch "B" = _____ Volts

Percent Voltage Drop Of Branch "B" = _____

Sketch:

Section 12 - Traffic Signal Design

12.1 General

This section is for use as a guide in the planning and design of the Traffic Signal Plan and Electrical Plan of a traffic signal installation that conforms to Department policy. It will provide a means of developing uniformity in the design and plan preparation of traffic signals.

The term "traffic signals" can include many types of control signals: pedestrian signals, lane-use control signals, hazard identification beacons, school sign flashing beacons, movable bridge signals, priority control signals, and railroad pre-emption. However, certain general design criteria can be applied to all traffic signals.

Complying with all of the design criteria is sometimes difficult. It will require some judgment on the part of the designer to draw the necessary balance. However, it is necessary that the criteria be followed as closely as possible in order to achieve uniformity of traffic signal design. It is recognized that situations will occur where good engineering judgment dictates deviation from this Department policy. Any such deviation shall be detailed in writing and submitted for approval to the Manager, Bureau of Traffic Engineering (BTE).

It is not the intent of this section to reproduce all the information that is adequately covered by textbooks and other publications that are readily available to the designer. This section, when used in conjunction with engineering knowledge of traffic signal design and good judgment, should enable the designer to perform their job more efficiently.

The terminology used in this section, unless stated otherwise, is as defined in the current addition of National Electrical Manufacturers Association (NEMA) Standard Publication No. TS-1, Part 1, entitled "Traffic Control Systems".

All traffic signal plans shall be produced to NJDOT and BTE Microstation CADD standards. Non-compliance to CADD standards will result in plan rejection.

12.2 Reference Publications

- FHWA - *Manual on Uniform Traffic Control Devices (MUTCD)*
- ITE - *Transportation and Traffic Engineering Handbook*
- FHWA - *Traffic Control Device Handbook*
- ITE - *Manual of Traffic Engineering Studies*
- ITE - *Manual of Traffic Signal Design*
- SPECIFICATIONS:
 - NJDOT - *Standard Specifications for Road and Bridge Construction*
 - NJDOT - *Special Provisions*
 - NJDOT - *Electrical Material Specifications*
 - AASHTO - *Standard Specifications for Structural Supports for Highway Signs, Luminaires and Traffic Signals*
- NFPA - *National Electrical Code (NEC)*

- NJDOT - *Standard Electrical Details*
- NJDOT - *Sample Plans*
- NJDOT - *CADD Manual*
- OSHA - *Code of Federal Regulations Title 29, Part 1926*

All publications shall be the latest edition.

12.3 General Design Criteria

12.3.1 Warrants for Traffic Signals

The NJDOT has adopted the MUTCD as the guideline for the design and application of traffic control devices on all state highway and all decisions with regard to traffic control devices shall be based on the MUTCD as provided by N.J.S.A. 39:4-120. All traffic signal installations must be warranted in accordance with the MUTCD and as noted in the MUTCD meeting a warrant does not constitute approval for signalization. A traffic signal warrant study must include sufficient vehicular and pedestrian counts, the latest three year detailed crash analysis at the intersection and a detailed plan or condition diagram of the intersection identifying the geometric features including intersection sight distance, existing traffic control devices and markings, spacing to existing signals and speed limits. In addition the engineer is required to provide a recommendation that if warranted the signalization is based on his analysis and investigation and that signalization is in the best interest of safety and the expeditious movement of traffic. BTE is responsible for review and approval of the traffic signal warranting analysis. The designer shall obtain BTE's approval that a traffic signal is warranted prior to starting the actual design of the traffic signal.

12.3.2 Traffic Signal Design –“TS” Plan - General

The NJDOT meets at least the minimum standards set forth in the MUTCD. However, in most cases a higher level design, that exceeds these minimum standards with respect to number and placement of signal heads and timing and operation of the signal, should be achieved.

The following section is intended to provide guidance to the designer in the development of the Traffic Signal (TS) Plan.

- All plans are to be prepared to, NJDOT and BTE Microstation CADD standards. All plans are to be scaled at 1 inch = 30 feet.
- All traffic signals on the state highway system are to be designed as semi-actuated signals with areas of presence detection, unless otherwise approved by BTE.
- All actuated traffic signals are to be designed utilizing pedestrian push- buttons that provide the pedestrian the ability to cross the State highway.
- The traffic signal timing and operation shall be shown on a separate plan sheet. In addition, the designer shall provide the timing and operation in WORD format on a CD and it submit to BTE.

A. Typical Signal Layout Considerations – General

NJDOT has adopted the near side left overhead – far side right overhead signal head placement as its basic design for each approach of a signalized

intersection. The near side left signal head over the roadway typically provides stop bar definition and it is to be located as close as possible to the stopline.

B. Signal Head Placement

The signal head placement is to conform as close as possible to the following:

- One Lane Approach;

The far side signal head is to be placed as close as possible over the center of the lane on the far side of the intersection. The near side signal head is to be placed as close as possible over the center of the opposing lane.

- Two Lane Approach;

The far side mast arm is to have one, preferably two, overhead signal heads. If only one signal head is used, it should be placed over the white line separating the two lanes on the far side of the intersection. If the approach has an exclusive turning lane(s), two signal heads are to be used. If the exclusive turn lane(s) has a protected phasing operation, an additional overhead signal head is to be provided for this purpose and be placed as close as possible over the center of this exclusive lane. The near side signal head is to be located over the opposing lane closest to the centerline.

- Three Lane Approach;

The far side mast arm is to have two to three overhead signal heads based on the number of receiving lanes and exclusive turn lanes. Generally, the number of heads corresponds to the number of receiving lanes for through movements, in addition to a head(s) used to control an exclusive turn lane. Placement of these heads should be located as close to the center of the lanes as possible. The near side signal head is to be located over the opposing lane closest to the centerline.

- Four Lane Approach;

The far side mast arm is to have three to four overhead signal heads based on the number of receiving lanes and exclusive turn lanes. Placement should be as described above in the 3 Lane Approach.

- Approaches with median or curbed barrier separating opposing traffic;

Signal heads shall be aligned over the roadway as noted above, except that in this case, the near side signal head will be placed to the left of the median or barrier curb, typically back to back with the far right through signal head for opposing traffic.

See page 47 of 86 in the Sample Plans that references the positions of signal head numbers 1 and 5 on the mast arms. Go to the following link.

<http://www.state.nj.us/transportation/eng/CADD/v8/pdf/SamplePlansEnglish.pdf>

C. Supplemental Signal Heads

Supplemental signal heads may be used in the design when justifiable by engineering judgment. The following is a brief description of the justifications for installing supplemental heads:

- Signal Heads for Stop line Definition;

For example, the near side signal head does not appear to provide adequate stop line definition due to geometric features. In the case of a right horizontal curve, a pole mounted signal head may be added to the left of the approach. It should be as close as possible to the stop line of that approach.

- Signal Heads for Pedestrians;

For some intersections, pedestrian activity is minimal and does not warrant the installation of pedestrian "WALK/DON'T WALK" signals. In such cases, a supplemental 3 section head may be installed, if a condition exists where a pedestrian could not fully view any other signal head in the intersection. This supplemental signal head will be pole mounted and aligned so that the pedestrian can view the signal face in the direction that the pedestrian wishes to cross.

- Signal Heads for Increased Advance Visibility;

The MUTCD provides the minimum sight distance required for viewing traffic signal heads. If the specified minimum distance is not met for continuous view of at least two signal faces, a warning sign is required and possibly an active (electrified) warning sign may be justified. In some cases the installation of a supplemental signal head in the appropriate location may provide adequate sight distance and negate the need for such warning devices.

D. Signal Heads for Protected Turning Movements

- Protected Left Turns

Protected left turn phasing is normally provided only at locations that have a dedicated left turn lane. This movement is to be controlled by a signal head consisting of red, yellow and green left arrows. Two signal heads are to be provided for this movement, one of which should be overhead. This overhead signal is normally designed as part of the far right signals on a mast arm. The left turn signal head is to be located a minimum of 1/3 of the way into the left lane, measured from the right edgeline marking that separates the left turn lane and the adjacent through lane.

- Protected Right Turns

For a non-channelized protected right turn movement, the signal head located on the far right side of the intersection on the mast arm is to consist of a standard three section signal head plus a bi-modal green/yellow right turn arrow in the fourth section. If a supplemental signal head is needed for pedestrians, then it also is to be a four section head in order for the pedestrian to not be in conflict with the protected vehicular phase.

For a channelized protected right turn movement, a pole mounted three section head consisting of red, yellow and green right turn arrows should be located on the right side of the approach. Where feasible, a far side pole mounted three section head consisting of red, yellow and green right turn arrows should be installed.

E. Detection

Detection is required for all traffic signals on the state highway system unless otherwise approved by TE. The primary form of detection to be integrated into a

signal design is image detection. Image detection shall be operated in the presence mode. The location of the image detection device should either be on the far side signal standard itself or mast arm, in accordance with the manufacturers' recommendations. The area of detection is 40 feet as measured back from the painted stop line.

If approved, the alternative type of detection is a loop detector that is operated in the presence mode. Specific details of the type and layout of loop detectors will be discussed in the subsequent electrical section of this chapter.

Under special circumstances BTE will approve the use of a force off detector. A typical situation is where the vehicle queue on a signalized approach, usually an off-ramp, could queue back and affect through traffic on the main highway. In the interest of safety, a special pre-emption sequence can be implemented to give a priority green phase to this approach to clear the queue. This sequence is initiated by recognition of a constant vehicle call (typically a minimum 5 seconds) on the strategically placed force-off detector. The location of the force-off detector is determined by the designer and is based on engineering judgment, geometry, peak hour traffic volumes and site observations.

12.3.3 Traffic Signal Timing and Operation - General

The foremost objective in the installation of a traffic signal is to assign sequential right of way to conflicting vehicular and pedestrian movements in a manner that is safe and efficient. In order to achieve signal efficiency, the most critical factor is the traffic signal timing and operation. In general, the first considerations for preparing a timing directive are as follows:

1. Cycle length
2. Clearance times
3. Pedestrian indications within a multi-phase operation
4. Protected versus protected - permissive left turn phases.
5. Emergency vehicle and railroad pre-emption sequences.

A. Coordination - Cycle Length

The designer shall investigate and provide a report of a total system design concept in each project. The Department currently utilizes several types of traffic signal systems as follows:

1. Time Base - Time base coordination, when installed at a group of intersections, provides a coordinated system without the use of interconnecting cables.
2. Closed Loop / Adaptive- continually monitoring intersection operations and system performance. The system is also capable of traffic responsive operation and providing maintenance reports. When the design of a project includes the installation or modification of a computerized traffic signal system, the Bureau of Mobility and Systems Engineering (MSE) shall be contacted for the proper system design criteria.
3. Isolated Intersection Control - Isolated intersection control is only utilized when coordination is not required, typically referred to as variable or free float operation.

The existing cycle used within a system of coordinated signals, in which a new signal is to be incorporated, dictates what cycle length is to be used. The most common cycle lengths used are 90 and 120 seconds. In order to determine the offset to the reference (master) signal, a time-space diagram of the entire system must be plotted. This type of signal operation will only service the side street call or pedestrian call at a point in the cycle where the offset is measured, thereby keeping the signal system in synchronization.

Traffic signals not in a coordinated system are typically designed with a variable cycle or a free float operation and are characterized by setting a minimum green to the main arterial. Once the minimum green time is met, any call on the side street or a pedestrian call will immediately terminate the main arterial green. The variable cycle is used in isolated rural areas where signal spacing is usually greater than 1 mile and signal coordination is not practical. It can also be used during late night and early morning hours to reduce vehicular delay on side streets in a coordinated system, when coordination is no longer critical.

B. Minimum Green–Yellow - Red Times

The minimum times allocated in traffic signal timing and operation should be as follows:

	Minimum
Actuated through movements -	7 second green
Lead left turn movements -	5 second green arrow
Yellow clearance -	3 seconds
Yellow arrow clearance -	3 seconds
All red clearance -	2 seconds
All red arrow clearance -	2 seconds

The above outlines the minimum times to be used when developing a signal timing plan. It is the responsibility of the designer to determine the total clearance time for the intersection, based on the speed of vehicles and the width of the intersection traversed.

C. NJDOT uses the following formula

$$\text{Total clearance time} = T + V/2a + (W + L)/V$$

Where T= Perception time (1 second)

a= Deceleration (10 ft/sec)

L= Length of vehicle (20ft.)

W= Crossing width

V= Velocity in ft/sec

By inserting the variables of W and V in the equation, the designer is able to calculate the total clearance time (yellow + all red).

The NJDOT rule for calculating the yellow change interval is:

One second for every 10 miles per hour (minimum of 3 seconds).

For speeds above 30 mph, the yellow time must be rounded upward.

EXAMPLES: 35MPH = 4 seconds yellow

45MPH = 5 seconds yellow

55MPH = 6 seconds yellow

After establishing the yellow time, it is then subtracted from the total clearance time calculated above to obtain the all red clearance time. As with the yellow time, the all red clearance time is always rounded upward. The phasing pattern must be known in order to determine the worst case (farthest) point of vehicle-vehicle or vehicle-pedestrian conflict. Actuated phases may or may not be skipped and therefore, the greatest travel length for "W" must be used to determine the total clearance.

12.3.4 Pedestrian Timing Considerations - General

Traffic signal designs for signals on the state highway system must consider the needs of pedestrians, based on factors such as signal standard location, operation and phasing complexity.

In some cases where the traffic signal is operating in the fixed-time mode, the minimum green time set for the minor cross street must satisfy the minimum pedestrian crossing time requirements. The designer should evaluate each signalized intersection for special considerations and meet the requirements of the MUTCD, such as designated school crossings that justify the installation of Walk / Don't Walk pedestrian signals.

Pedestrian Timings

The NJDOT standard pedestrian signal is the countdown Walk / Don't Walk signal. The minimum walk time allocated should be 7 seconds. The pedestrian clearance time is calculated using the longest crosswalk length, curb to curb, and dividing this by the MUTCD walking rate. Lower walking speeds may be used where justified by an engineering study. When developing a signal timing and operation plan, it is important to begin with the fixed parameters such as yellow change, all red clearance and the pedestrian clearance phase. The walk time for the actuated phases is then determined, according to the capacity constraints of each individual intersection. It should be noted that the sum of pedestrian actuated Walk and Flashing Don't Walk times do not have to equal the vehicle actuated maximum green time for the same approach. If higher, a vehicle extension line should be incorporated into the timing plan to account for green time in excess of the side street maximum green.

12.3.5 Pre-Emption

Pre-emption of traffic signals on the State highway system includes:

Emergency Fire and Rescue, Railroad and Movable Bridge pre-emption.

A. Emergency Fire and Rescue

If an emergency traffic signal is found to be justified or if an existing traffic signal is identified as needing a pre-emption sequence, the State will only install a hard wire connection within State right of way up to the fire/rescue house, if it is within one thousand feet of the traffic signal. Any installation and maintenance of equipment, needed beyond State right of way and within the

fire/rescue house, to operate the traffic signal pre-emption will be the responsibility of the party having jurisdiction of the fire/rescue house.

In no case will the State participate in the purchase, installation and maintenance of any "Optical" system or other system used to remotely initiate a pre-emption sequence.

If pre-emption is approved, a timing sequence needs to be developed that provides adequate time to allow for safe egress of the fire/rescue vehicles. Care should be taken to ensure that all timing plans have a sufficient guaranteed minimum green time to the main street to avoid the display of a "flash" green. All vehicular and pedestrian clearances times should be guaranteed. The latter however can be truncated as per the MUTCD.

B. Railroad

Railroad pre-emption follows a similar timing sequence pattern, but may not assign the right of way to any approach, i.e. red to all approaches, because the train has the right of way at all times. When designing a railroad pre-emption, special care should be taken in locations that have channelized free flow right turns that direct traffic toward the grade crossing. Blank-out turn prohibition signs should be considered and designed to initiate and terminate with the traffic signal pre-emption.

Railroad pre-emption is to be incorporated at all locations where vehicle queues could reach the tracks from a traffic signal any distance away. In most cases, the Department will typically conduct a Diagnostic Team meeting. A formal Docket is prepared delineating the equipment and traffic control devices to be constructed at the grade crossing and directs the installation of a traffic signal pre-emption, if warranted.

C. Movable Bridge

Typically separate traffic control signals are already included on the bridge approaches to specifically stop inbound traffic, upon preemptive actuation. When a signalized intersection is located on either or both sides of a movable bridge, the outbound movements off of the bridge are subject to pre-emption, since the potential exists for vehicles to queue on the bridge. The preemptive sequence shall address the required clearance interval, based on vehicle start up delays. To avoid gridlock of the intersections during long bridge openings, the traffic signal design(s) is to include blank-out signs and a rest phase for the non-conflicting adjacent street movements.

12.3.6 Temporary Traffic Signals

When an existing traffic signal is affected by the construction, they shall be revised as follows:

- A. Where possible, all existing equipment should be left in place while the proposed signal is constructed. The designer shall provide a scheme of the construction to verify that the equipment can be left in place. A scheme shall be provided for each stage of construction, which includes detailed temporary wiring and any safety protection, if required.
- B. A temporary signal shall be included in the contract whenever an existing signal must be removed prior to the completion of the new signal.

- C. If a signal is being removed as part of the design and not replaced, the designer shall indicate the stage of construction that the signal will be removed.
- D. When an existing signal is part of a "system", the Bureau of Mobility and Systems Engineering (MSE) shall also be notified and the system aspect of the signal shall be their responsibility.

NJDOT uses temporary traffic signals exclusively during construction projects, when it is deemed necessary to control traffic by a traffic signal for a stage or stages of a project and it is not possible to install or maintain a permanent traffic signal. The typical temporary signal consists of a two pole span wire arrangement that spans the intersection diagonally. Standards are typically placed on the near left and far right corners of the major street approaches to facilitate meeting the MUTCD cone of vision requirements. A four pole box span is also an option to minimize span length.

Because all signal heads are typically located on one span wire, the dead load is maximized on the cable and poles. Since temporary traffic signals are used exclusively on construction projects, each two pole and cable system must be structurally designed individually and certified by a Professional Engineer, licensed in the State of New Jersey, usually the project designer. The certified plans and calculations must be submitted to the Bureau of Structural Engineering for approval. The designer shall provide plans, timing, details and certified structural calculations supporting the design and the material to be used.

With the diagonal placement of the span wire, the designer must give consideration to the lateral placement of signal head and possible spillover of illumination to a conflicting movement. Tunnel visors, louvers or other methods may be required to control spillover.

The temporary signal must be designed specific to each stage and, whenever possible, incorporate the maximum number of signal heads for all stages to minimize over-roadway signal head shifts in the field. Image detection and pedestrian push-buttons are to be included. The use of image detection will permit the signal to operate in the semi-actuated mode and therefore be more efficient. The image detection is then available for repositioning to accommodate multiple stages at the signal. Like permanent traffic signals, highway lighting shall be provided in the temporary traffic signal design.

12.3.7 Traffic Signal Controller

The current Department standard is an eight phase fully actuated traffic signal controller. The controller is a microprocessor based digital unit with a minimum of dual ring quad left or sequential operation, as specified in the current NJDOT Specification Nos. EB-TSC-ITB-8 and EB-TSC-8CL.

The designer shall review the timing sequence to insure that an eight phase traffic signal controller can perform it. The controller shall not require external timers or timing relays to perform the timing sequence. The designer, in all cases, must consider and utilize the overlapping pedestrian movement or concurrent traffic movements. The timing schedule is placed on a separate plan sheet.

The controller is the most important component of the traffic signal; therefore, the designer must use extreme care in choosing a location for the controller at the intersection. As a minimum, the following criteria shall be adhered to:

- Offset the controller as far as possible from the traveled roadway within the right-of-way, allowing adequate work area for maintenance.
- Provide the maintainer the best possible visibility of the signal indications when working on the cabinet.
- The controller location shall be the least vulnerable to vehicular accidents and not restrict sidewalk areas.

12.3.8 Traffic Signal Standards

Types, designs and certain typical installation details for traffic signal standards and their foundations are included in the NJDOT Standard Electrical Details.

Aluminum traffic signal standards and transformer bases shall be of aluminum alloy to support traffic signal mast arms with a length of 25 feet or less. When the mast arm exceeds 25 feet, the traffic signal standard shall be steel.

The Traffic Signal Standard "C" is used when required to obtain the minimum roadway overhead clearance for signal heads mounted over the roadway.

The roadway overhead clearance of the signal head must be examined and calculated when a traffic signal standard, particularly "T", is installed at the low side of a banked section of roadway.

Traffic Signal Standard "K" is the preferred standard to be used for 25 foot mast arms.

The designer is responsible for loading calculations necessary to verify that the standard and arms will support the signal indications and signs. All mast arm signs are free swinging in accordance with the standard details.

Traffic Signal Standard "KE" shall only be used for mounting pole top luminaries. Arms are not to be attached to the "KE".

Locate traffic signal standards as follows:

- A. The minimum offset is 32" from face of curb or edge of pavement to center of the standard.
- B. Steel traffic signal standards are located 10 feet from the face of the curb when possible. A minimum of 5 feet from the face of the curb to the center of the steel traffic signal standard should be maintained.
- C. Traffic signal standards shall not be located in areas of handicap ramps nor shall they obstruct the crosswalks.
- D. Use traffic signal standards, where feasible, to support pedestrian signals and push buttons.
- E. Traffic signal standards shall not be located on the traffic side of (in front of) the guiderail or any natural or manmade deflecting barrier. The location must provide the distance necessary for rail deflection when struck and a reachable distance for pedestrians to push the pedestrian push button. Exceptions on a case by case basis may be made only with approval of BTE.
- F. Traffic signal standards shall not be located near the curve of:
 - A corner with a radius of less than 15 feet, or;
 - A corner with a radius of less than 30 feet provided where trucks and buses turn right occasionally, or;

- A corner with a radius of less than 50 feet provided where large truck combinations and buses frequently turn right.
- G. The designer is responsible for locating and identifying the horizontal and vertical clearances of the utility company's primary (750 volts or more) and secondary power lines and assure that the minimum clearances are in accordance with the *New Jersey Administrative Code Chapter 25 Utility Accommodation*, Section 16:25-5.3 (b). The designer coordinates the electrical design work with the present and future plans of the utility companies. All overhead and underground utilities must be shown on the plans. There shall be no conflicts with the lighting and traffic signal installation.

12.3.9 Traffic Signal Indications

The location and type of indications shall be approved and/or determined by BTE.

12.3.10 Intersection Lighting

Intersection lighting is included as part of the traffic signal design at all signalized intersections and conforms to Section 11 Subsection, "Lighting at Intersections". The intersection lighting shall be installed on Traffic Signal Standards, "C", "SC", or "K" with a "KE" extension.

12.3.11 Conduits

Rigid metallic conduits (RMC) 3" in diameter, is used throughout for all traffic signal cables. Conduit size for loop detector cables is 1-1/2" in diameter. Conduit size for overhead electrical services and telephone services is 2" in diameter or as required by the utility company. Typical details regarding conduit installations are included in the standard electrical details.

Rigid nonmetallic conduits (RNMC) may be used for interconnect conduits between intersections or for conduits to control "Red Signal Ahead" signs. Install a ground wire if nonmetallic is installed.

12.3.12 Cables and Wires

All cables and wires, including neutrals, to be used for traffic signal circuits and incoming secondary service shall conform to the specifications and shall be fully color coded. The designer provides a block wiring diagram as shown on NJDOT Sample Plans. The block wiring diagram indicates the cable letter for each cable extending from the controller to the base of the traffic signal standard. The letters are to be assigned sequentially to cables terminating at the far corner first, then to cables terminating at the next corner as the first group passes through (east corner then north corner; south corner then west corner, as shown in the NJDOT Sample Plans). The designer calculates the wire fill of all conduits to insure conformance to the National Electrical Code. The following cable areas are used for wire fill:

Cable	Cross Sectional Area
10/C #14	0.322 sq. in.
5/C #14	0.166 sq. in.
2/C #14	0.105 sq. in.

The designer provides sufficient wire from each traffic signal standard to the controller; however, in order to avoid a redundancy in the wiring system, the following

traffic signal faces may be wired in parallel in the base of an individual traffic signal standard:

- Traffic signal faces of a main street or side street on the same phase, provided there is exclusive left turn signal phase.
- Traffic signal faces of a minor side street, provided they are on the same phase and most likely they will not be on separate phases or will not have an exclusive left turn phase in the future.

The signal cables are brought directly to the controller. The designer shall observe the following criteria:

- All vehicular indications are wired on a 10/C #14 cable. A 5/C #14 may be used when only one indication is on the pole.
- All pedestrian indications are wired on a 5/C #14 cable.
- All push buttons are individually wired on a 2/C #14 cable.
- All loop detectors are wired with a 2/C (twisted pair) #14 cable. Each loop detector has its own twisted pair of detector lead-in wires and are connected separately to a channel of the detector unit.
- Each traffic signal circuit of a load switch must be less than 10 amperes; provide calculations for the circuits of more than 7 amperes.
- Lighting circuits installed as part of the traffic signal installation will utilize the same conduit system as the traffic signal circuits and conform to Section 11, "Roadway Lighting Systems". The wire size is #8 AWG or as required.

12.3.13 Vehicular Detection

A. Image Detection

1. On all new traffic signal designs, Image Vehicle Detection will be used. The area of detection will be the same as when designing inductive loops. The Plan will be labeled "AREA OF DETECTION".
2. On all revisions to traffic signal designs that involve vehicle detection changes, Image Vehicle Detection will be used. The area of detection will be the same as when designing inductive loops. The Plan will be labeled "AREA OF DETECTION".
3. The Image Detection unit (camera) must be placed aiming the camera as straight as possible to the area of detection, trying not to view the area of detection on an angle.

B. Inductive Loop Detection

The Department also installs inductive loop detectors for vehicular detection. A series of short loops shall be installed to cover the area of detection determined by the traffic engineer. Other types of detectors are used only in areas where the loops could not be installed, such as a steel bridge deck.

Installation of inductive loop detectors conforms to the following guidelines:

1. Under normal conditions a diamond shaped loop, which is approximately 6' x 6' in the direction of travel, is utilized to cover the area of detection. The largest loop is 6' x 18'.

2. Loops directly behind the stop line are designed as small as possible to guarantee the detection of motorcycles stopped directly behind the stop line.
3. The designer should first try to use a series of four short loops. Where the area of detection cannot be covered with a four-loop layout, additional loop(s) should then be considered as shown in Figure 12-A.
4. The longitudinal spacing between two loops shall be in the range of 5 feet to 16 feet. The spacing shall decrease gradually as a vehicle approaching the intersection reduces its speed.
5. Except in areas of parking, the side edge of a loop shall have a lateral spacing of 3 feet from a curb or pavement edge and 3 feet from a painted double yellow line or a white line.
6. Under normal conditions the front edge of the loop immediately behind the stop line is no more than 2 feet from the top of the stop line. The maximum spacing between loops adjacent to the stop line shall be 5 feet. A spacing of less than 5 feet for these loops may be used to meet the requirements set forth in the next item (7).
7. The distance from the front edge of the area of detection to the intersection shall be as shown on Figure 12-A. In the case of a skewed intersection, the dimension shall be measured perpendicular from the extension of the curblines to the front loop. In no case shall any portion of the loop extend beyond the extended curblines into the intersection area. In some cases, depending upon the skew angle, a supplemental loop should be required to insure that vehicles overriding the stop line will not leave the area of detection.
8. When a loop is used mainly as a system loop or a dual function loop (local intersection detection and system detection), it shall be a 6' x 6' rectangular shaped loop and installed in the center of the traveling lane in which volume counts are to be taken.
9. A force-off loop and motion loop shall be of rectangular shape and installed at locations determined by the traffic engineer.
10. All loops shall be identified alphabetically and in sequence as a vehicle approaches the intersection.

The designer will field check each intersection to select proper loop locations. This field check must consider driveway locations, pavement conditions, manhole locations, width and skew of the roadway, power sources and other electrical equipment that will interfere with proper loop operation.

In summary, the final decision concerning the size, shape, spacing and location of loop detectors for proper traffic control is a combination of analytical procedures and application of good engineering judgment.

When detection is needed on bridges, the use of probes, preformed loops, microwave, video and infrared detectors shall be investigated.

12.3.14 Junction Boxes

Use 18" x 36" junction boxes for the traffic signals.

Use 17" x 30" junction boxes only for loop wires and loop detector lead.

Junction boxes shall not be installed in handicap ramp areas. The placement of junction boxes should also avoid sidewalk areas whenever possible.

In order to facilitate cable pulling and splicing, install a junction box adjacent to traffic signal standard(s), the controller, loop detectors and at each end of conduit crossings under roadways.

The location of conduit crossings should be so arranged that the junction boxes at terminals of such conduits could also be used as service points to the above noted facilities. Junction boxes are designed to accept a maximum of six conduits. In cases where the number of conduits and cables are in excess of the junction box capacity, except in front of the controller where two junction boxes may be installed, the design should be re-examined.

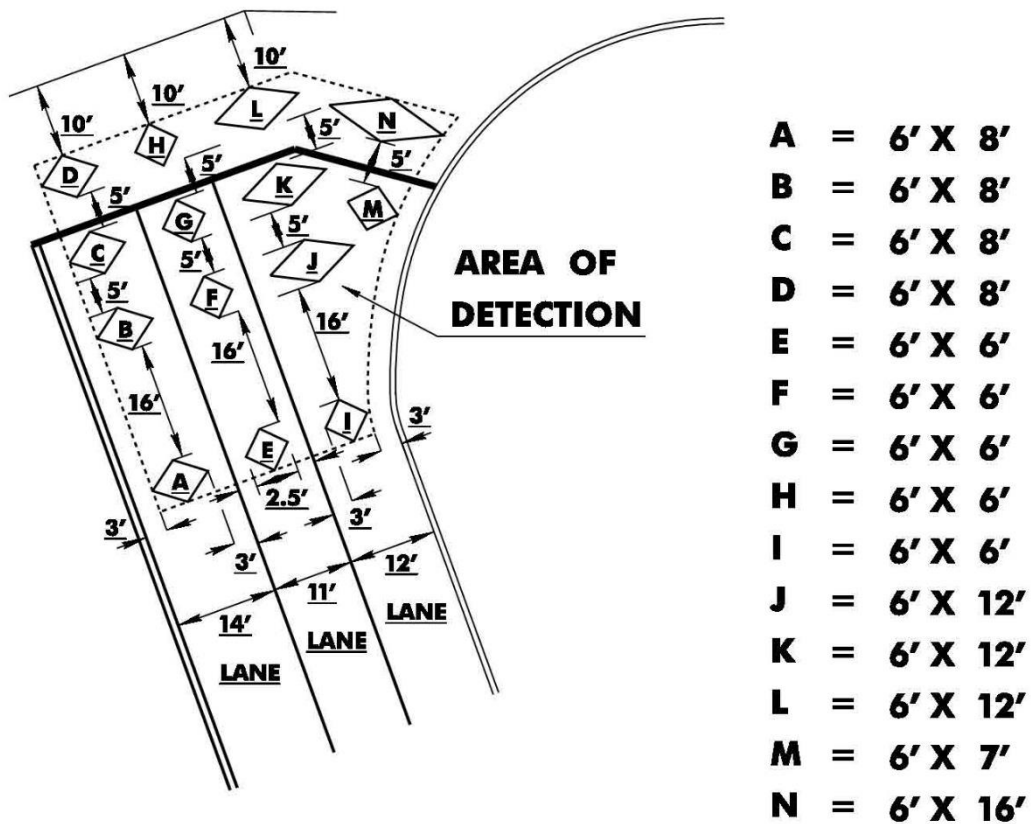
12.3.15 Incoming Service

The secondary service, obtainable from the local utility company's pole or manhole, shall be used to service the complete installation at each intersection. Standard services shall be single phase, 3-wire, 120/240-volt, utilizing #6 AWG. When service is obtained from a manhole, the designer shall consult the utility company for the size, location, material and termination of the service conduit, and the installation of the service wire.

The designer shall prepare a written preliminary request for service to the local utility company indicating the required service and obtain their written approval including any utility company assigned request number. Information on the continuous load and payee of the energy charge shall also be provided in the letter.

A copy of the letter shall be sent to the Manager, Bureau of Traffic Engineering (BTE).

**FIGURE 12-A:
LOOP LAYOUT**



NOTE: ALL LOOP DIMENSIONS ARE NOMINAL

REV. DATE: JUNE 30, 2015

Section 13 - Ground Mounted Sign Supports

13.1 Introduction

Highway signs fall into two main categories, which are subdivided as follows:

1. Overhead Signs
 - a. Sign Bridge Structures (GO)
 - b. Sign Cantilever Structures (GO)
 - c. Bridge Mounted (GOX)
2. Ground Mounted Signs
 - a. Small Highway Signs (GA)
 - b. Large Highway Signs (GA)

This section covers the design guidelines for Ground Mounted Sign Supports. These guidelines have been developed utilizing the 2011 AASHTO *A Policy on Geometric Design of Highways and Streets*, the 2009 AASHTO *Standard Specifications for Structural Supports for Highway Signs, Luminaires and Traffic Signals*, the 2011 AASHTO *Roadside Design Guide*, and the 2009 *Manual on Uniform Traffic Control Devices for Streets and Highways* (MUTCD).

Designers are to ensure that all new signs or those signs to remain in a project conform to the requirements of the 2012 Supplemental Guide Signing Manual.

<http://www.state.nj.us/transportation/eng/documents/BDC/pdf/SGSM2012.pdf>

Design guidelines and standard drawings for overhead and cantilever signs are covered in the NJDOT *General Design Criteria and Standard Drawings for Overhead and Cantilever Sign Support Structures*, 2007.

The designer has four options from which to choose when locating signs within the highway right-of-way. These options are:

1. Locate the sign beyond the clear zone.
2. Mount the sign overhead.
3. Utilize a breakaway support to reduce impact severity
4. Shield the sign with a longitudinal barrier and/or crash cushion

Ground mounted signs should desirably be located beyond the clear zone. In addition, all ground mounted highway signs are to be installed on breakaway supports, unless otherwise indicated herein. When a small sign is located behind a traffic barrier (which is required for another reason), non-breakaway supports may be used. In cases where noise walls are required at a particular sign location, additional berm widths may be necessary.

In considering the above, it is critical that sign locations and the design of the sign support be considered early in the Initial Design Development Stage. Depending upon the size of the sign, additional right-of-way, or slope easements may be required (see Standard Roadway Construction Details CD-612-4 and CD-612-7 for grading details). Also, where sign supports must be shielded, sufficient area must be provided to accommodate guide rail, crash cushions, or other traffic barriers.

13.2 Small Highway Signs

Small highway signs are defined as those with total panel areas less than 50 square feet. When this category of sign is used, the design guidelines for its support shall be steel "U" post sign supports. Aluminum posts are not permitted for small highway signs. Small highway signs shall not be placed in front of guide rail, and the posts shall not straddle guide rail. All small highway sign supports shall be of the breakaway type with the exception of those installed behind guide rail or behind other traffic barriers.

For those signs included in the NJDOT Standard Roadway Construction Details (CD-612-1, 2 and 3), the contractor shall be responsible for determining the horizontal offset, the quantity of posts, the post size and their associated lengths by utilizing the information provided in Standard Roadway Construction Details CD-612-4.

For signs not included in the NJDOT Standard Roadway Construction Details, the designer shall be responsible for establishing all offsets, quantity of posts, post sizes and lengths by following the step-by-step design guidelines below:

- Step 1 Once provided with the necessary panel size, determine the horizontal offset (X1) from edge of pavement to inside edge of sign, as shown in Figure 13-A, by applying Section 2A.19 of the MUTCD as follows:
- a. Urban installations – In areas where lateral offsets are limited, a minimum lateral offset of 2 ft. is desirable. A minimum offset of 1 ft. from the face of the curb may be used in areas where the sidewalk width is limited or where existing poles are close to the curb.
 - b. Rural installations – 6 ft. minimum desirable from edge of shoulder, but 12 ft. minimum desirable from edge of traffic or auxiliary lane.
 - c. Interstate and Freeway installations – 6 ft. minimum from edge of shoulder, but not less than 12 ft. from the edge of traffic or auxiliary lane.
 - d. Ramp installations – 6 ft. minimum from edge of road.
 - e. Behind guide rail: 4 ft. minimum from back of beam guide rail element to sign post.
- Step 2 When determining the height of ground mounted signs, the following checks should be made:
- a. When signs are installed on slopes 10H:1V or flatter the minimum vertical clearance above the edge of pavement to bottom of the sign panel as shown in Figure 13-A is as follows:
 - (1) Sign Panels:
For single post installations, the minimum distance above the edge of pavement to the bottom of any panel must be 7 ft. and the minimum distance from edge of pavement to the top of any sign panel must be 9 ft.
For multi-post installations, the minimum distance above the edge of pavement to the bottom of a main sign panel must be 7 ft.
 - (2) Secondary Sign Panels:
For land service highways, the minimum distance above the edge of pavement to the bottom of a secondary sign panel is 6 ft.

For interstate and freeways the bottom of the main sign shall be a minimum of 8 ft. and secondary sign panel a minimum of 5 ft. above the edge of pavement.

- b. Where the sign is beyond the clear zone or behind a traffic barrier, the 10H:1V slope or flatter grading requirement may be eliminated. Where grading of 10H:1V or flatter cannot be obtained or where there is curb or berm greater than 4 inches, the minimum vertical clearances will be measured from the ground line to the bottom of the sign.

Where a sign is behind a traffic barrier, regardless of grading, use directions in Step 2a above. Also, the sign under clearance at the far edge of a multi-post sign is 1 ft. minimum in a cut section.

- c. When the height of the sign panel falls below the 7 ft. level, engineering judgment should be exercised to avoid placing these signs in or near pedestrian crossing areas.

Step 3 Determine the maximum distance (L) from the ground line to the centroid of the sign panel in feet and determine the sign panel area (A) in square feet.

NOTE:

Sign Supports shall not be placed on slopes steeper than 10H:1V except where grading of 10H:1V cannot be obtained or where they will be behind a traffic barrier. See Standard Roadway Construction Details CD-612-4 for the grading detail.

Step 4 Determine the size and quantity of posts per sign from Figure 13-B for "A" up to 50 S.F. and "L" from 7 ft. to 15 ft.

NOTE 1:

When the plotted values of "A" and "L" on Figure 13-B indicate an undefined section of the chart, then an alternate design for large highway signs must be initiated (see Section 13.3, "Large Highway Signs").

NOTE 2:

When there is an option of using either a 2.5 lb/ft post or a 4.0 lb/ft post, the following applies:

- a. The maximum sign width (W) for single post installations shall be 2.5 ft.
- b. If the number of posts selected are the same, the 2.5 lb/ft post should be used.
- c. When the number of 2.5 lb/ft posts selected are greater than the number of 4 lb/ft posts, the 4 lb/ft posts should be used.

Example: A = 20 S.F.

L = 10 ft

Roadside Slope = 10H:1V

From Figure 13-B, the number of posts that may be selected are:

three – 2.5 lb/ft posts or,

two – 4.0 lb/ft posts

Therefore, use two – 4.0 lb/ft posts.

Step 5 After completing Steps 1 through 4 for each sign, determine the post length(s) (P) and enter all the data onto the Steel "U" Post Sign Support Data Table of the Standard Roadway Construction Details CD-612-6 for that project.

The following is an example of a post selection for a non-standard sign:

Highway Type - Freeway

Sign No. GA - 4

Size: 10 ft. x 4 ft

Roadside Slope < 10H:1V

From the information provided:

Area (A) = 40 S.F.

Horizontal offset (X1) = 6 ft. (min.)

Vertical clearance = 7 ft. (min.)

Ground line to centroid (L) = 9 ft

From Figure 13-B:

Use three - 4 lb/ft posts

Distance between posts = $W/3 = 40$ inches (see Figure 13-A)

Post Length (P) = $7 + 4 = 11$ ft

Finally, enter the data onto the Steel "U" Post Sign Support Data Table in the Standard Roadway Construction Details CD-612-6.

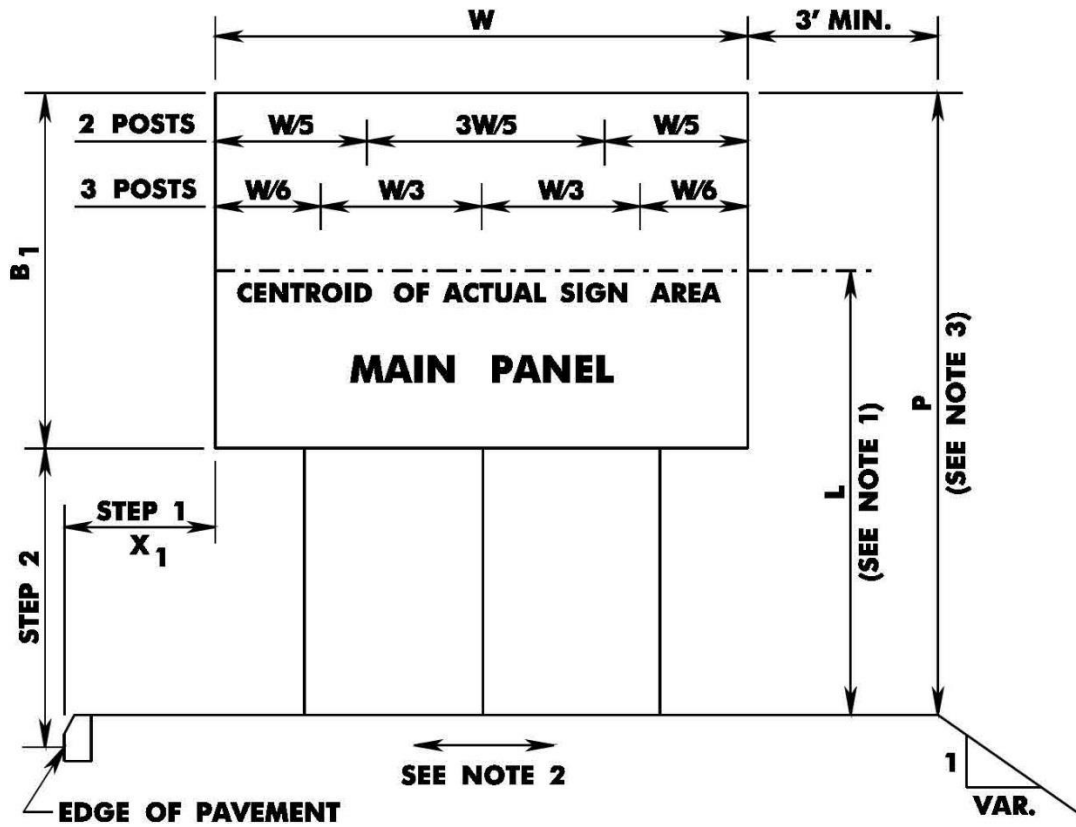
13.3 Large Highway Signs

Large GA highway signs are defined as those with a panel area equal to or greater than 50 square feet. When this category of sign is used, the design guidelines for the support shall be "Breakaway Sign Support". Details for breakaway sign supports are contained in the *NJDOT Standard Roadway Construction Details* (CD- 612-7 through CD-612-10).

New sign supports for large GA highway signs shall be breakaway including sign supports that are installed behind roadside barriers used to shield other roadside obstructions. When a breakaway sign support is placed behind guide rail, the support should be a minimum of 4 ft. from the back of rail to the face of the sign post. When a breakaway sign support is placed behind barrier curb, the support shall be a minimum of 1.5 ft. from the back of barrier curb to the face of the sign post. In no case shall the leading edge of the sign panel project beyond the face of a roadside barrier.

Existing tubular aluminum GA breakaway signs that have been impacted should be replaced in-kind unless the damage is severe enough to require new footings, signs and/or posts. Existing large permanent GA signs, Specific Service signs (Logo signs) and Tourist-Oriented signs on wooden posts should be replaced with the breakaway sign system discussed below. All new large Specific Service signs (Logo signs) and Tourist-Oriented signs shall be installed with the breakaway supports discussed below.

**FIGURE 13-A:
SIGN ELEVATION FOR STEEL U-POST SUPPORTS**



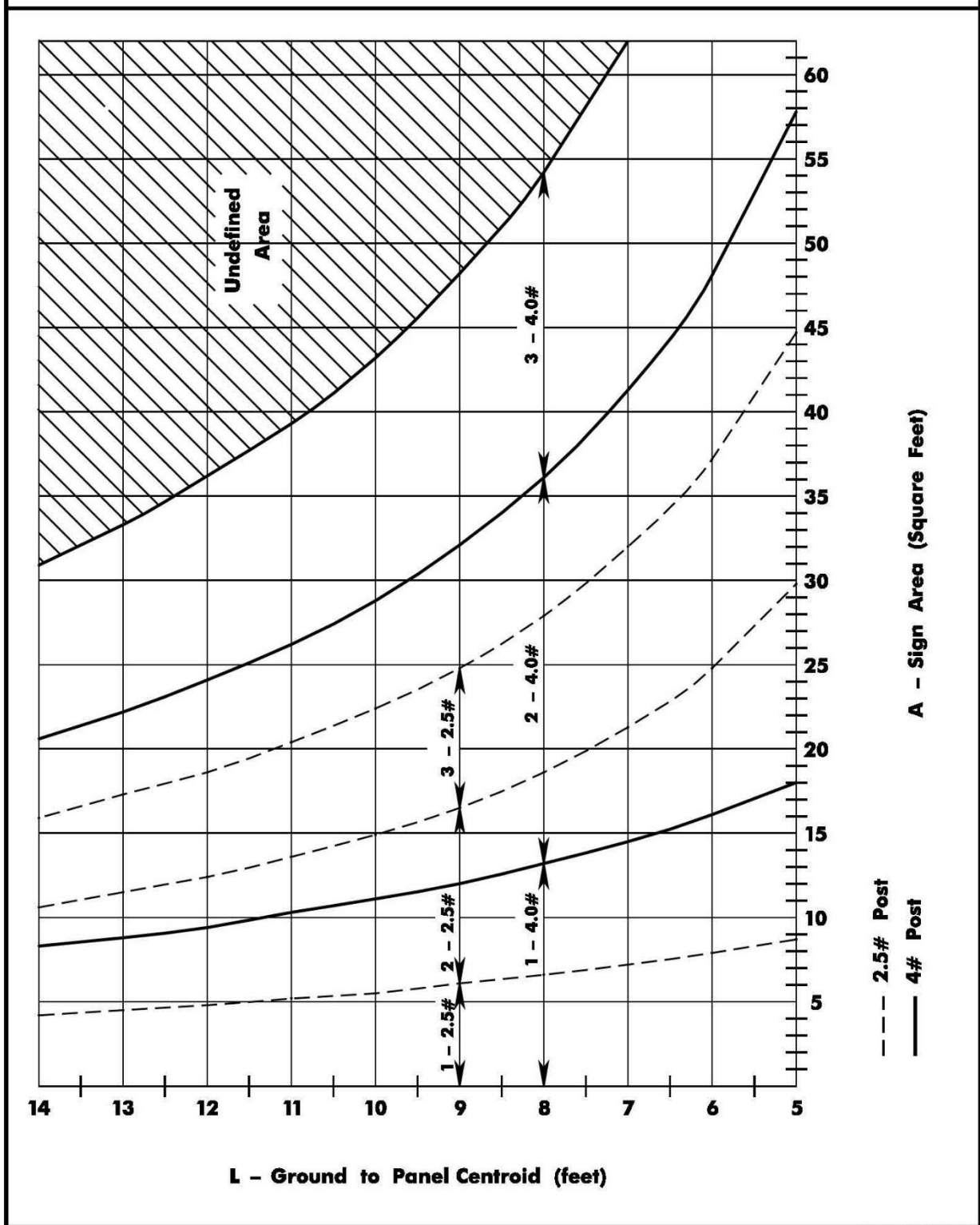
NOTE 1: L = Maximum Distance From Ground To Centroid Of Sign Panel In Feet.

NOTE 2: Slopes Should Not Be Greater Than 10H:1V

NOTE 3: P = Post Length

REV. DATE: JUNE 30, 2015

**FIGURE 13-B:
NUMBER OF STEEL U POSTS PER SIGN**



13.3.1 Breakaway Sign Supports

The following is a step-by-step guide to the design of breakaway sign supports:

- Step 1 Once provided with the size of the main panel, determine the horizontal offset, X_1 , from the edge of pavement to the edge of panel. Recommended offset = 8 ft., minimum offset = 7 ft.
- Step 2 Determine the elevation from the edge of pavement to the bottom of the main panel. Minimum mounting height = 7 ft. (see Figure 13-C and 13-D).
- For fill sections, when the sign is within the clear zone and not behind a traffic barrier, a 6H:1V slope or flatter must be held for a minimum of 3 feet beyond the berm (far) side of the main panel and 100 feet ahead of the sign face (see Standard Roadway Construction Detail CD-612-7).
 - For cut sections, when the sign is within the clear zone and not behind a traffic barrier, hold the far edge bottom corner of the main panel at the 7.271 ft. minimum and provide a 6H:1V slope or flatter for a minimum of 3 ft. beyond the berm (far) side of the main panel and 100 ft. ahead of the sign face (see Figure 13-D and Standard Roadway Construction Detail CD-612-7). If the sign is beyond the clear zone or behind a traffic barrier, the clearance at the far edge bottom corner of the main panel may be 1 foot.
 - When the sign is beyond the clear zone or behind a traffic barrier, the 6H:1V slope or flatter grading requirement may be eliminated.
- Step 3 Determine the number of posts required for the specified panel based on a minimum spacing between posts of 7 ft. (see Figure 13-C).

Note: For main panel widths less than 22 to 23 ft., depending on post (flange) width, a three post support system shall not be used. Since the spacing for the three post support system requires $A_1/3$ between sign posts, only a 22 to 23 ft. width or greater would provide the 7 ft. minimum required spacing between posts (face of post to face of post). Since the spacing for the two post support system requires $3A_1/5$ between sign posts, only a 12.5 to 13 ft. width or greater would provide the 7 ft. minimum required spacing between posts (face of post to face of post). See Table 13-1 below for minimum panel length (A_1) based on post (flange) width.

Table 13-1

POST SIZE	FLANGE WIDTH	MIN. PANEL WIDTH (A_1)	
		2 POST SIGN	3 POST SIGN
W6X12	4"	12.5'	22'
W6X16	4"	12.5'	22'
W8X18	5.25"	12.5'	22.5'
W8X21	5.25"	12.5'	22.5'
W10X22	5.75"	12.5'	22.5'
W10X26	5.75"	12.5'	22.5'
W12X26	6.5"	13'	23'
W14X30	6.75"	13'	23'
W18X35	6"	12.5'	22.5'
W18X40	6"	12.5'	22.5'

For a two post support system, $A_1 = 5 (7' + \text{Flange Width}) / 3$

For a three post support system, $A_1 = 3 (7' + \text{Flange Width})$

Step 4 Determine the distances from ground line to bottom of main panel, L , for each post.

NOTE:

The minimum distance from ground line to the bottom of the main panel shall be 7.271 ft.

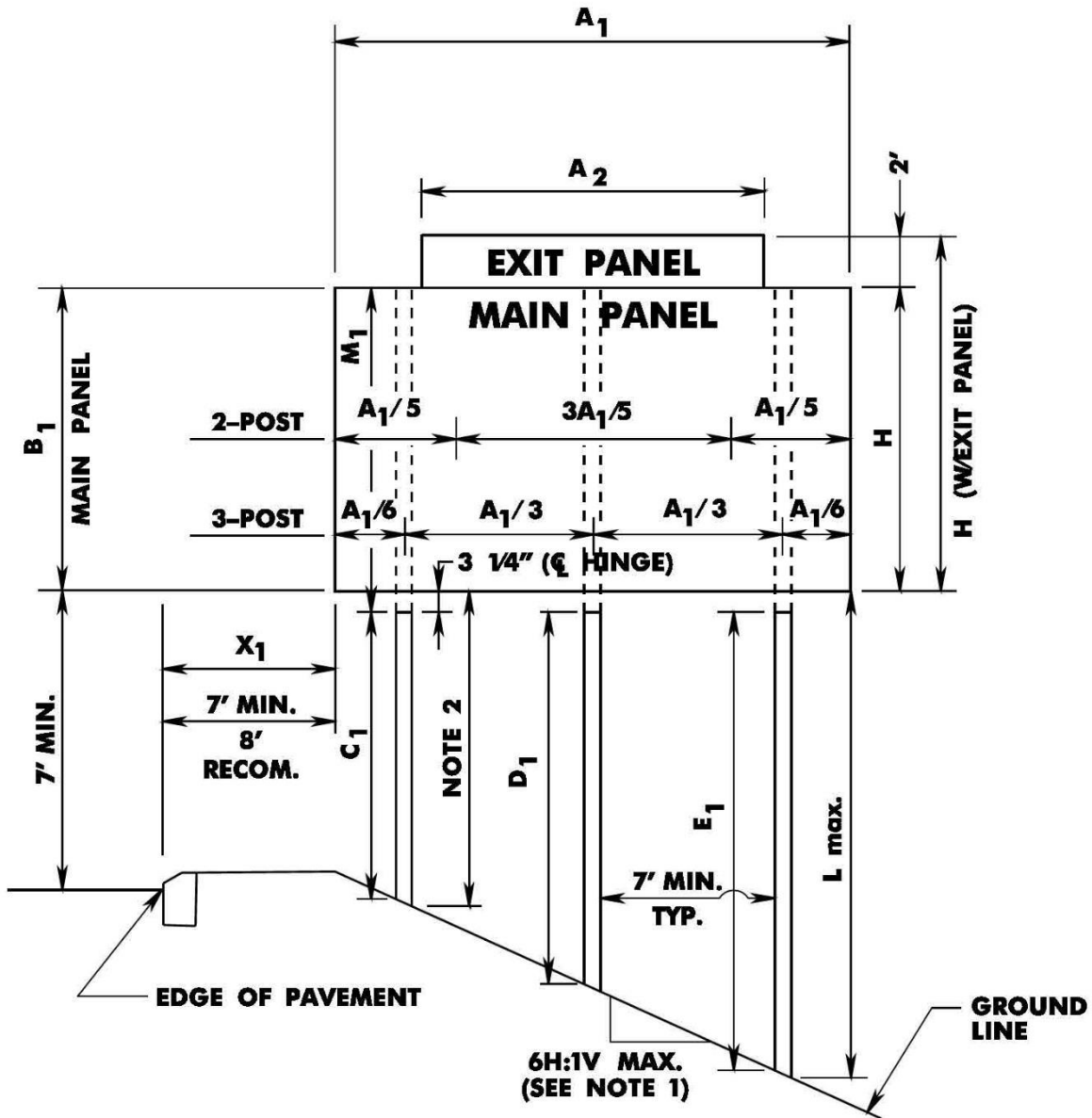
Step 5 Determine the required values of L_{max} , H , and $A1$ where:

L_{max} = Maximum post length to bottom of main panel (feet)

H = Main panel height + Exit panel height (feet)

$A1$ = Main panel width (feet)

**FIGURE 13-C:
SIGN EVALUATION FOR BREAKAWAY SUPPORTS FILL SLOPES**

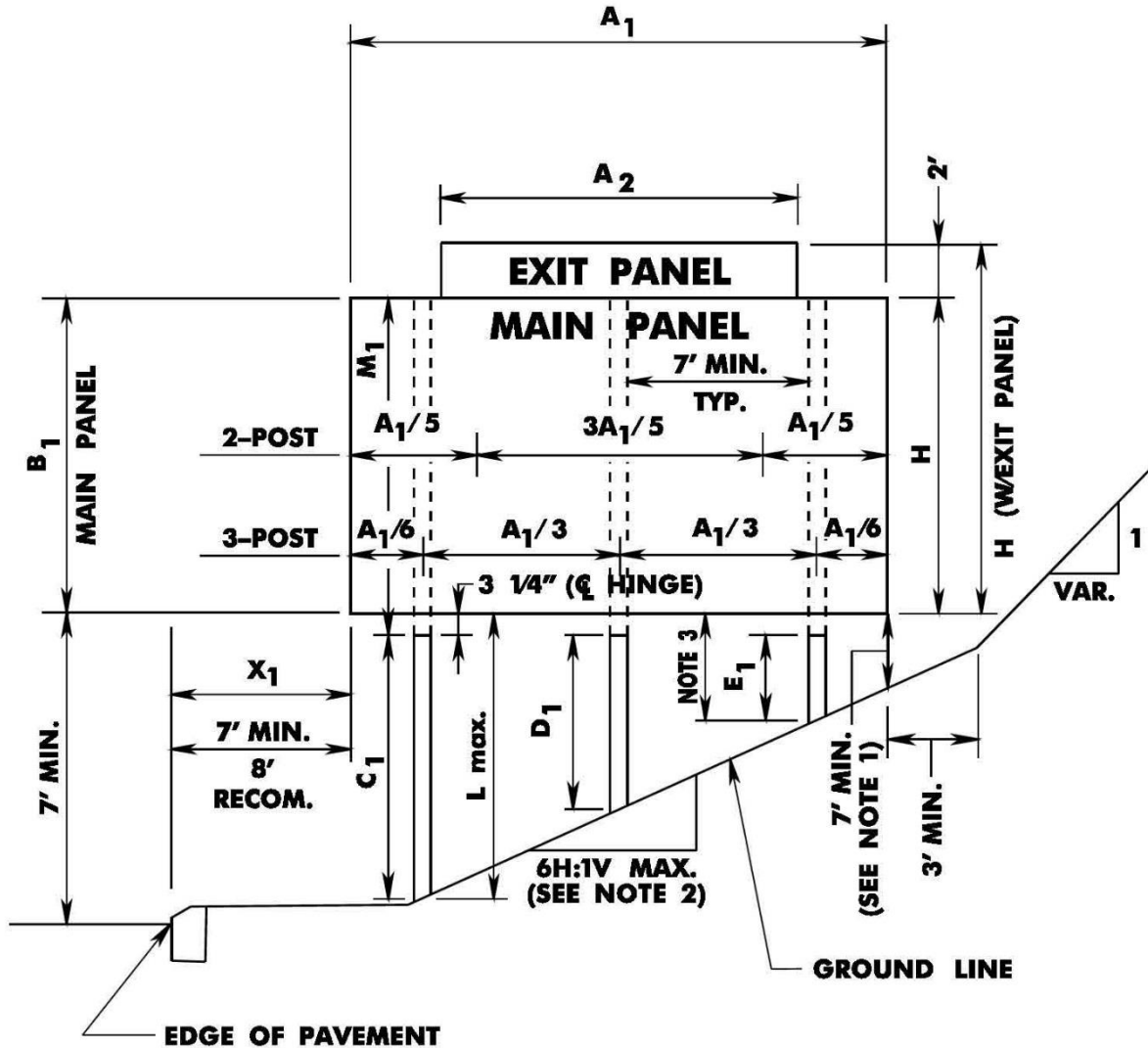


NOTE 1: Fill slope may be 2H: 1V maximum when sign is behind a traffic barrier or beyond clear zone.

NOTE 2: Minimum clearance from ground line to bottom of main panel at shortest post is 7.271 ft. when sign is within clear zone and not behind a traffic barrier.

REV. DATE: JUNE 30, 2016

**FIGURE 13-D:
SIGN ELEVATION FOR BREAKAWAY SUPPORTS CUT SLOPES**



NOTE 1: Sign underclearance at far end of sign is 1 foot minimum when sign is behind a traffic barrier or beyond the clear zone.

NOTE 2: Back slope may be 2H: 1V maximum when sign is behind a traffic barrier or beyond clear zone.

NOTE 3: Minimum clearance from ground line to bottom of main panel at shortest post is 7.271 ft. when sign is within clear zone and not behind a traffic barrier.

REV. DATE: JUNE 30, 2015

- Step 6 Determine the sign support size by utilizing Tables 13-3.1, 13-3.2, and 13-4, where:

L_{max} = Maximum post length to bottom of main panel (feet)

H = Main panel height + Exit panel height (feet)

A_1 = Main panel width (feet). For main panel widths (A_1) between those shown in Tables 13-3.1, 13-3.2 and 13-4, use larger width to determine post size.

Note: Posts in Tables 13-3.1, 13-3.2, and 13-4 were designed for a basic wind speed of 100 mph (3-second gust speeds), with a yield stress for the steel I-beam of 36,000 psi, and a structure design life of 25 years.

Example: L_{max} = 10 ft. H = 9 ft. A_1 = 24 ft.

Based on the information provided, it is determined according to Step 3 that a two or three post system can be used. The designer should pick the post system that is the most cost effective for their job. This example will continue with a two post system. Entering Table 13-3.1 with the given values above, select a W12x26 post. This post size shall be used for all posts in the structure.

- Step 7 Determine the footing diameter, footing depth and vertical rebar requirement:

Using the post size determined in Step 6, use Table 13-2 determine the footing diameter, footing depth and vertical rebar requirement (see Figure 13-E).

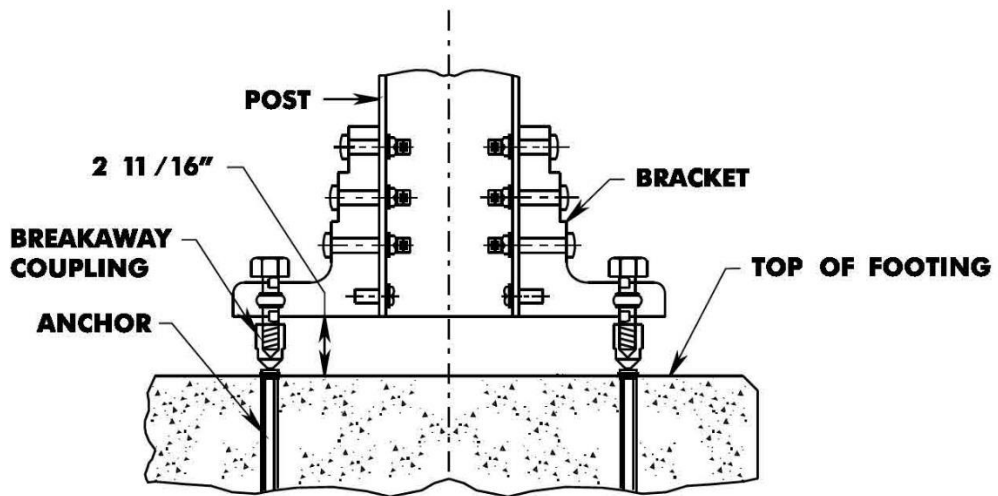
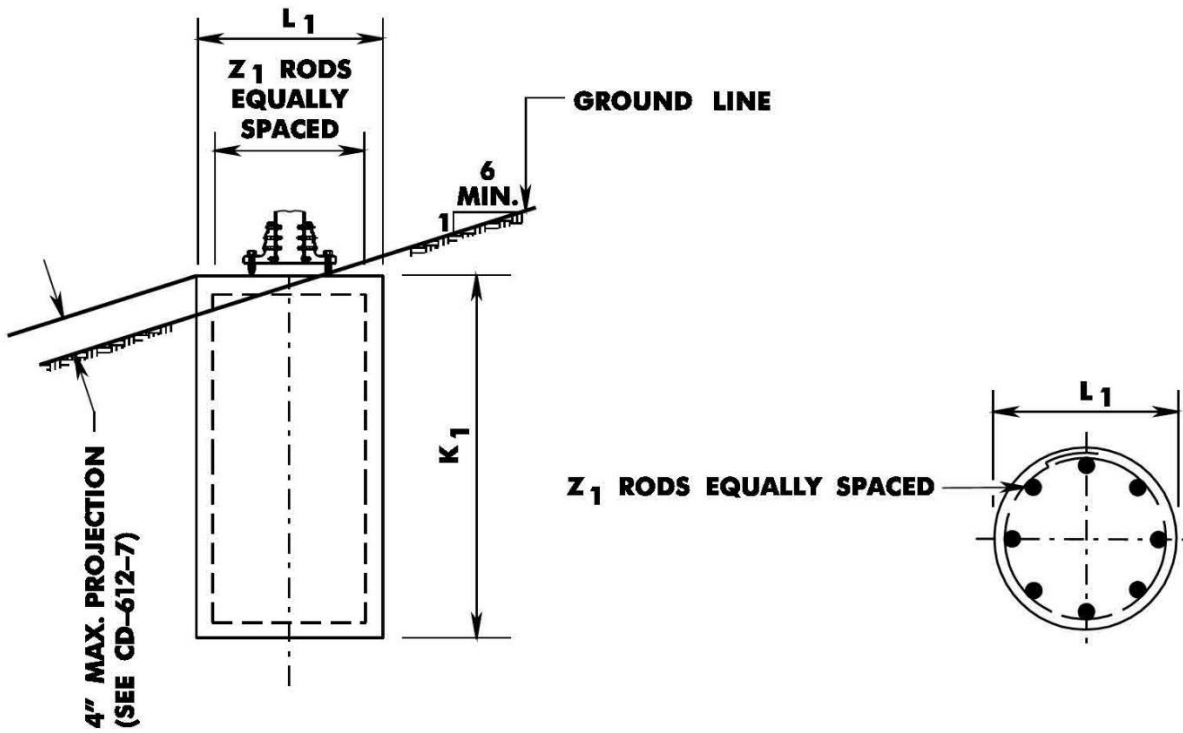
Example: post size = W12x26

Footing Diameter, 3.0 ft.; Footing Depth, 8.0 ft.; Re-Steel, 8-#19

TABLE 13-2

Footing Dimensions			
Post size	Footing Diameter (L1)	Footing Depth (K1)	Re-Steel (Z1)
W6x12, W6x16	2.5'	5.5'	8-#16
W8x18, W8x21	2.5'	6.5'	8-#16
W10x22, W10x26	3.0'	7.5'	8-#19
W12x26	3.0'	8.0'	8-#19
W14x30	3.0'	8.0'	8-#19
W18x35, W18x40	3.5'	8.0'	8-#19

**FIGURE 13-E:
FOOTING DETAIL FOR BREAKAWAY
SIGN SUPPORTS**



SEE CD-612-7 & CD-612-8 FOR FURTHER DETAILS

POST SELECTION TABLE FOR BREAKAWAY SIGNS TWO POSTS							TABLE:-13-3.1		
		H = MAIN PANEL HEIGHT+ EXIT PANEL HEIGHT FEET)							
A1	Lmax	4	5	6	7	8	9	10	
14	8	W6x12	W6x16	W6x16	W8x18	W8x18	W8x18	W8x18	
	10	W6x16	W8x18	W8x18	W8x18	W8x21	W8x21	W10x22	
	12	W8x18	W8x18	W8x18	W8x21	W10x22	W10x26	W10x26	
	14	W8x18	W10x22	W10x22	W10x26	W10x26	W12x26	W12x26	
	16	W10x22	W10x26	W12x26	W12x26	W12x26	W14x30	W14x30	
16	8	W6x12	W6x16	W8x18	W8x18	W8x18	W8x21	W8x21	
	10	W8x18	W8x18	W8x18	W8x18	W8x21	W10x22	W10x22	
	12	W8x18	W8x18	W8x21	W10x22	W10x22	W10x26	W12x26	
	14	W8x21	W10x22	W10x26	W10x26	W12x26	W12x26	W14x30	
	16	W10x22	W10x26	W12x26	W12x26	W14x30	-----	-----	
18	8	W6x16	W6x16	W8x18	W8x18	W8x18	W8x21	W10x22	
	10	W8x18	W8x18	W8x18	W8x21	W10x22	W10x22	W10x26	
	12	W8x18	W8x21	W10x22	W10x22	W10x26	W12x26	W12x26	
	14	W8x21	W10x22	W10x26	W12x26	W12x26	W14x30	W18x40	
	16	W10x26	W12x26	W12x26	W14x30	-----	-----	-----	
20	8	W6x16	W8x18	W8x18	W8x18	W8x21	W10x22	W10x22	
	10	W8x18	W8x18	W8x21	W8x21	W10x22	W10x26	W12x26	
	12	W8x18	W8x21	W10x22	W10x26	W10x26	W12x26	W14x30	
	14	W10x22	W10x26	W12x26	W12x26	W14x30	W14x30	W18x40	
	16	W10x26	W12x26	W12x26	W14x30	-----	-----	-----	
22	8	W6x16	W8x18	W8x18	W8x21	W8x21	W10x22	W10x26	
	10	W8x18	W8x18	W8x21	W10x22	W10x26	W10x26	W12x26	
	12	W8x18	W10x22	W10x22	W10x26	W12x26	W14x30	W14x30	
	14	W10x22	W10x26	W12x26	W12x26	W14x30	W18x40	W18x40	
	16	W12x26	W12x26	W14x30	-----	-----	-----	-----	
24	8	W6x16	W8x18	W8x18	W8x21	W10x22	W10x26	W10x26	
	10	W8x18	W8x18	W8x21	W10x22	W10x26	W12x26	W12x26	
	12	W8x21	W10x22	W10x26	W10x26	W12x26	W14x30	W18x40	
	14	W10x22	W10x26	W12x26	W14x30	W18x40	W18x40	-----	
	16	W12x26	W12x26	W14x30	-----	-----	-----	-----	
26	8	W8x18	W8x18	W8x18	W8x21	W8x21	W10x26	W12x26	
	10	W8x18	W8x21	W10x22	W10x26	W10x26	W12x26	W14x30	
	12	W8x21	W10x22	W10x26	W12x26	W12x26	W18x35	-----	
	14	W10x22	W12x26	W12x26	W14x30	W18x40	-----	-----	
	16	W12x26	W14x30	-----	-----	-----	-----	-----	
28	8	W8x18	W8x18	W8x21	W10x22	W10x26	W10x26	W12x26	
	10	W8x18	W8x21	W10x22	W10x26	W12x26	W14x30	-----	
	12	W8x21	W10x22	W10x26	W12x26	W14x30	-----	-----	
	14	W10x26	W12x26	W14x30	W18x40	W18x40	-----	-----	
	16	W12x26	W14x30	-----	-----	-----	-----	-----	
30	8	W8x18	W8x18	W8x21	W10x22	W10x26	W12x26	-----	
	10	W8x18	W8x21	W10x22	W10x26	W12x26	W14x30	-----	
	12	W10x22	W10x26	W12x26	W12x26	W14x30	-----	-----	
	14	W10x26	W12x26	W14x30	W18x40	-----	-----	-----	
	16	W12x26	W14x30	-----	-----	-----	-----	-----	

POST SELECTION TABLE FOR BREAKAWAY SIGNS TWO POSTS					TABLE:-13- 3.2	
		H = MAIN PANEL HEIGHT+ EXIT				
A1	Lmax	11	12	13	14	15
14	8	W8x21	W10x22	W10x22	W10x26	W10x26
	10	W10x22	W10x26	W12x26	W12x26	W14x30
	12	W12x26	W12x26	W14x30	W14x30	W18x35
	14	W14x30	W14x30	W18x40	W18x40	-----
	16	-----	-----	-----	-----	-----
16	8	W10x22	W10x22	W10x26	W10x26	W12x26
	10	W10x26	W10x26	W12x26	W14x30	W14x30
	12	W12x26	W14x30	W14x30	W18x35	W18x40
	14	W14x30	W18x40	W18x40	-----	-----
	16	-----	-----	-----	-----	-----
18	8	W10x26	W10x26	W10x26	W12x26	W14x30
	10	W12x26	W12x26	W14x30	W14x30	-----
	12	W14x30	W14x30	W18x40	-----	-----
	14	W18x40	W18x40	-----	-----	-----
	16	-----	-----	-----	-----	-----
20	8	W10x26	W12x26	W12x26	W14x30	-----
	10	W12x26	W14x30	-----	-----	-----
	12	W18x35	-----	-----	-----	-----
	14	-----	-----	-----	-----	-----
	16	-----	-----	-----	-----	-----
22	8	W12x26	W12x26	-----	-----	-----
	10	W14x30	W14x30	-----	-----	-----
	12	-----	-----	-----	-----	-----
	14	-----	-----	-----	-----	-----
	16	-----	-----	-----	-----	-----
24	8	W12x26	-----	-----	-----	-----
	10	W14x30	-----	-----	-----	-----
	12	-----	-----	-----	-----	-----
	14	-----	-----	-----	-----	-----
	16	-----	-----	-----	-----	-----
26	8	W12x26	-----	-----	-----	-----
	10	-----	-----	-----	-----	-----
	12	-----	-----	-----	-----	-----
	14	-----	-----	-----	-----	-----
	16	-----	-----	-----	-----	-----
28	8	-----	-----	-----	-----	-----
	10	-----	-----	-----	-----	-----
	12	-----	-----	-----	-----	-----
	14	-----	-----	-----	-----	-----
	16	-----	-----	-----	-----	-----
30	8	-----	-----	-----	-----	-----
	10	-----	-----	-----	-----	-----
	12	-----	-----	-----	-----	-----
	14	-----	-----	-----	-----	-----
	16	-----	-----	-----	-----	-----

POST SELECTION TABLE FOR BREAKAWAY SIGNS TWO POSTS					TABLE:-13- 3.2	
		H = MAIN PANEL HEIGHT+ EXIT				
A1	Lmax	11	12	13	14	15
14	8	W8x21	W10x22	W10x22	W10x26	W10x26
	10	W10x22	W10x26	W12x26	W12x26	W14x30
	12	W12x26	W12x26	W14x30	W14x30	W18x35
	14	W14x30	W14x30	W18x40	W18x40	-----
	16	-----	-----	-----	-----	-----
16	8	W10x22	W10x22	W10x26	W10x26	W12x26
	10	W10x26	W10x26	W12x26	W14x30	W14x30
	12	W12x26	W14x30	W14x30	W18x35	W18x40
	14	W14x30	W18x40	W18x40	-----	-----
	16	-----	-----	-----	-----	-----
18	8	W10x26	W10x26	W10x26	W12x26	W14x30
	10	W12x26	W12x26	W14x30	W14x30	-----
	12	W14x30	W14x30	W18x40	-----	-----
	14	W18x40	W18x40	-----	-----	-----
	16	-----	-----	-----	-----	-----
20	8	W10x26	W12x26	W12x26	W14x30	-----
	10	W12x26	W14x30	-----	-----	-----
	12	W18x35	-----	-----	-----	-----
	14	-----	-----	-----	-----	-----
	16	-----	-----	-----	-----	-----
22	8	W12x26	W12x26	-----	-----	-----
	10	W14x30	W14x30	-----	-----	-----
	12	-----	-----	-----	-----	-----
	14	-----	-----	-----	-----	-----
	16	-----	-----	-----	-----	-----
24	8	W12x26	-----	-----	-----	-----
	10	W14x30	-----	-----	-----	-----
	12	-----	-----	-----	-----	-----
	14	-----	-----	-----	-----	-----
	16	-----	-----	-----	-----	-----
26	8	W12x26	-----	-----	-----	-----
	10	-----	-----	-----	-----	-----
	12	-----	-----	-----	-----	-----
	14	-----	-----	-----	-----	-----
	16	-----	-----	-----	-----	-----
28	8	-----	-----	-----	-----	-----
	10	-----	-----	-----	-----	-----
	12	-----	-----	-----	-----	-----
	14	-----	-----	-----	-----	-----
	16	-----	-----	-----	-----	-----
30	8	-----	-----	-----	-----	-----
	10	-----	-----	-----	-----	-----
	12	-----	-----	-----	-----	-----
	14	-----	-----	-----	-----	-----
	16	-----	-----	-----	-----	-----

Step 8 Determine the model number from Table 13-5.

From the post size determined in Step 6, select the Model No.

Example: From Step 6, the post size determined was W12x26. Therefore, use Model No. B650.

TABLE 13-5

Model No. Selection				
Post Size	Model No.		Post Size	Model No.
W6x12	B525		W10x22	B650
W6x16	B525		W10x26	B650
W8x18	B525		W12x26	B650
W8x21	B525		W14x30	B650
			W18x35	B650
			W18x40	B650

Step 9 Determine the bracket number from Table 13-6.

Calculate L for the longest post ($L = L_{max} + H/2$). Using L and the post size determined in Step 6 enter Table 13-6 and select the appropriate bracket number.

Example: $L = 10 + 9/2 = 14.5$ ft. From Step 6 the post size was determined to be W12x26. Entering Table 13-6 with a 12 inch post and an L of 14.5 ft., select Bracket No. 2.

TABLE 13-6

Bracket Selection						
I-Beam Post Size	Bracket No. 1		Bracket No. 2		Bracket No. 3	
	Min 'L'	Max 'L'	Min 'L'	Max 'L'	Min 'L'	Max 'L'
6"	12'	29'	9'	12'	0	9'
8"	14'	29'	10'	14'	0	10'
10"	16'	29'	11'	16'	0	11'
12"	18'	29'	13'	18'	0	13'
14"	19'	29'	14'	19'	0	14'
18"	23'	29'	16'	23'	0	16'

- Step 10 Determine C1, D1, E1 and M1 for each sign post, where:
- C1, D1, and E1 = Distance from 0.271 ft. (3 ¼ inches) below the bottom of the sign to bottom of bracket (see CD-612-7 and CD-612-8).
 C1, D1, and E1 = Step 4 – (0.224 ft. + 0.271 ft.)
NOTE: 0.224 ft. (2 11/16 inches) corresponds to the distance from top of footing to the bottom of the bracket (see Figure 13-E).
 M1 = Distance from the top of sign to 0.271 ft. (3 ¼ inches) below the bottom of the sign (B1+0.271).
- Step 11 Determine F1, G1, and H1 for each post, see *Standard Roadway Construction Details* CD-612-7. Values above reference line are positive, values below reference line are negative.
- Step 12 The footings should extend a maximum of 4" above the ground. Determine the maximum projection of the footings as per the Footing/Stub Projection Detail in *Standard Roadway Construction Detail* CD-612-7. If the projection is greater than 4 inches, then the footing will have to be beveled. Determine footing bevel as per Footing Bevel Detail and Footing Bevel Table in *Standard Roadway Construction Details* CD-612-7 and CD-612-10 respectively. If possible, lower the elevation of the top of footing to reduce projection to 4 inches or less, then footing bevel is not required. Detail Breakaway Grading Detail, Footing/Stub Projection Detail and Footing Bevel Detail do not apply to signs behind a traffic barrier or beyond the clear zone, as per *Standard Roadway Construction Details* CD-612-7.
- Step 13 Enter all the data onto the Breakaway Support Data Table and Footing Bevel Table in the *Standard Roadway Construction Details* CD-612-10.
- Note:** The Break-Safe Sign Post Selection program on the compact disk is for DOT engineers, consultants and sign contractors. Using input from the designer, this program will automatically select the appropriate sign post section and the corresponding Break-Safe breakaway sign support assembly. To receive a personal copy of the Break-Safe Sign Post Selection CD, go to <http://www.transpo.com/customer-service/contact-us>, fill in the form and request the Sign Post Selection CD. The designer will need to enter the design criteria for wind speed, yield stress of steel I-beam and structure design life into the program, see note in Step 6 above.

13.3.2 Non - Vegetative Surface under Overhead Signs and Large Ground Mounted Signs

In order to reduce soil erosion and highway maintenance costs associated with spraying or trimming vegetation underneath signs, non-vegetative surfaces should be applied around the foundation of overhead signs and underneath large ground mounted signs as follows:

- A. Sign types – Conditions warranting use of non-vegetative surfaces
 1. Overhead Signs
 2. Sign Bridge- All cases
 3. Sign Cantilever – All cases
 4. Large Ground Mounted Signs
 5. Breakaway Sign Supports – Mowable areas

6. Nonbreakaway Sign Support – Mowable areas

This surface treatment is not to be used at breakaway steel "U" post sign support locations. The non-vegetative surfaces shall be constructed as shown in Standard Roadway Construction Detail CD-608-1.

13.4 Raised Pavement Markers

Regardless of the lighting conditions, designers shall include Raised Pavement Markers (RPM) on all HMA surfaces, except for thin overlays less than 2" over bare concrete pavement, to supplement traffic stripes. Develop the placement of RPMs as per the Standard Roadway Construction Details.

13.5 Traffic Stripes and Traffic Markings

The following provides the Department Policy on Traffic Stripes, Traffic Markings and Raised Pavement Markers.

1. On interstate highways, all permanent lane lines, longitudinal edge lines and edge lines on (curbed and uncurbed) ramps shall be 6 inch wide epoxy resin traffic stripes. The traffic stripes shall be calculated in linear feet for each 6 inch width of actual stripe (gaps are not counted) under the item TRAFFIC STRIPES, 6".
2. On non-interstate highways, all permanent longitudinal center, edge and lane lines, edge lines on ramps, curbed and uncurbed ramps on Freeways and left turn slots shall be 4 inch wide epoxy resin traffic stripes. Permanent lane lines separating exclusive right or left turning lanes from through lanes shall be 8" wide epoxy resin traffic stripes. The traffic stripes shall be calculated in linear feet for each 4 inch width of actual stripe (gaps are not counted) under the item TRAFFIC STRIPES, 4".
3. All permanent gore lines, crosswalks, stop lines, words, arrows and other pavement symbols shall be thermoplastic. The gore lines, crosswalks and stop lines shall be calculated in linear feet for each specific width (4", 8", 12", 16", 20", 24", etc.) of marking line under the item TRAFFIC MARKINGS LINES, __". The words, arrows and other pavement symbols shall be calculated in square feet under the item TRAFFIC MARKINGS SYMBOLS. The route symbols shall be calculated in square feet under the item TRAFFIC MARKINGS ROUTE SYMBOLS.

Refer to Section 14 - Traffic Control Plans and Details for the design criteria of Latex Traffic Stripes and Traffic Markings.

Section 14 - Traffic Control Plans and Details

14.1 Introduction

This Section along with the Traffic Control Details presented in the Standard Roadway Construction / Traffic Control / Bridge Construction Details and the Traffic Control Plans and Traffic Control and Staging Plans presented in the Sample Plans were prepared to provide designers with general guidelines and examples of minimum desirable applications for typical situations requiring lane closures and/or lane shifts. This information may be used along with the current Manual on Uniform Traffic Control Devices (MUTCD) Part VI to prepare more detailed and site specific Traffic Control Plans that will enable the contractor to construct the project with adequate consideration of safety to motorists, pedestrians and construction workers.

Designers should not refer to or use the Traffic Control Details without proper evaluation of the specific site constraints and construction procedures required to construct the project. Traffic Control Plans should be prepared in accordance with the current Sample Plans. The Traffic Control and Staging methods established for each project should be consistent with the general provisions of this Section and should be based on good safety practices, engineering judgment, the speed and volume of traffic, the duration of the operation, the exposure to potential hazards, sight distance constraints and the physical features of the roadway including horizontal alignment, vertical alignment and the presence of intersections and driveways.

14.2 General

The first two sheets of the Traffic Control Plans should be Standard Traffic Control Detail sheets TCD-1 and TCD-2 as appropriately modified for individual project needs. These sheets contain a standard legend of typical traffic control devices, general traffic control notes, an escape ramp detail, a typical section for placement of construction barrier, a table showing recommended spacing of the channeling devices and a table showing recommended sight distances to the beginning of channelizing tapers. The legend and general traffic control notes should be reviewed and modified to include other project specific symbols and notes as necessary for each project. The standard sheets can also be modified to include other project specific information necessary to adequately address traffic control needs. Where required for clarification, sectional views showing the placement of traffic control devices adjacent to the traveled way and the work site should be provided.

Additional Traffic Control Plans should follow standard sheets TCD-1 and TCD-2. These additional plans should be included to show plan views of project specific work sites when those locations need to be represented or where design features of traffic control devices (such as the type of precast construction barrier) or temporary pavement markings need to be indicated. The scale of the Traffic Control Plans should be selected so that the optimum amount of information is shown on a minimum number of plan sheets. The Traffic Control Plans should include a tabulation of the channelization devices needed for the project.

As a minimum, Traffic Control Plans should include the following items:

- Required lane widths for each staging plan
- Grading for temporary roadways and crossovers

- Detours with respective detour signing
- Pay items for temporary work
- Temporary drainage associated with traffic staging
- Temporary staging for drainage and other utilities
- Temporary traffic signals and associated signal phasing design
- Signing for each staging plan
- Traffic control and safety devices that are necessary for each stage of construction
- Township and county
- Graphic scale and north arrow
- Allowable working hours
- Accommodation for Pedestrian traffic (i.e. locations of temporary sidewalks)
- Appropriate use of temporary / permanent barriers and end treatments
- Appropriate plans and specifications to address safety concerns

14.3 Traffic Control and Staging Plans

Traffic Control and Staging Plans should be utilized when a staging or sequence of construction needs to be specified. Notes pertaining to the various stages of construction should be included on these plans. The notes should thoroughly describe each phase of construction in the sequence to be performed.

The Legend on standard sheets TCD-1 and TCD-2 should be modified to show symbols for the work to be performed during each stage of construction and for work completed while construction is being performed during subsequent stages. When temporary pavement areas are required, a typical section should be provided.

During all phases of paving, staging should provide for a minimum exposure to drop-offs and uneven pavement adjacent to and between travel lanes.

To improve the riding quality of new bituminous concrete pavements, wherever practical, the top layer of the bituminous concrete surface course should be paved as a single stage of construction for the full width of the traveled way, shoulder and auxiliary lanes. Therefore, development of the Traffic Control and Staging Plans for projects involving paving operations should specify a Construction Sequence in which work progresses up to the bottom of the top layer of the surface course. The top layer should be shown as the final paving stage.

Designers should, upon completion of Traffic Control Plans, review the use of Unbound Paving Materials in those portions of roadway under improvement which will incur extensive traffic as a result of stage construction. In these situations, the designer should substitute Bituminous Stabilized Base Course for the Unbound Material. This substitution may be made without a Supplemental Pavement Recommendation. If this situation occurs during construction, the Resident Engineer should make this change.

14.4 Traffic Impact Report

As part of the development of the Traffic Control Plans, designers should conduct an analysis of construction related impacts. Findings should be presented in a detailed Traffic Impact Report that addresses the following items:

1. The existing traffic volumes and capacity data on the roads likely to be substantially impacted.
2. The projected traffic data at the start of construction including nearby highway construction projects as well as private construction projects.
3. The potential impacts of the construction on traffic through the project and along any detours.
4. Recommendations for traffic impact mitigation, e.g., nighttime work, restricted hours of operation, number of lanes available for traffic, width of lanes, requirement for alternating traffic, staging requirements, public information program, and transportation demand management strategies such as park and rides, shuttle buses, flextime, etc.

The Bureau of Transportation and Corridor Analysis should be consulted during the development and approval of the data in items 1, 2 and 3. The Regional Traffic Operations Unit should be consulted during the development and approval of the recommendations contained in item 4.

14.5 Development of Traffic Control Plan Design Parameters

The Department recognizes the need to effectively and efficiently manage traffic through construction projects in order to reduce congestion, maintain high levels of safety for workers, pedestrians and motorists, and minimize impacts to the local community both business and residential.

To this end, the scoping, design, scheduling and construction of projects should be accomplished in a manner that will provide a high level of safety for workers and the traveling public, minimize congestion and community impacts by maintaining levels of service close to preconstruction levels and provide the contractor with adequate access to the roadway to complete the work efficiently, while meeting the quality requirements of the contract.

In order to achieve these objectives, designers can utilize the NJDOT Road User Cost Manual to evaluate potential alternatives, in terms of cost to the traveling public. Project should be designed to minimize road user costs impacts. This may be accomplished through a variety of means including, but not limited to, reduced daytime hours, nighttime operations, detours, diversionary roads, crossovers, use of shoulders as travel lanes, temporary roads and bridges, and alternating traffic patterns. The incorporation of design elements to ease traffic impacts during future construction should also be considered. These could include wider lanes, shoulders or right of way, full depth shoulders, removable sidewalks on bridges, and other alternatives.

The basic safety principles governing the design of permanent roadways and roadsides should also govern the design of construction, maintenance and utility work sites. The goal should be to safely route traffic through these areas with geometrics and traffic control devices, as nearly as possible, comparable to those for normal highway

situations. The following items should be considered in determining the overall approach to project specific traffic control:

1. Regarding hours of operation or lane restrictions, consideration should be given to the location of the project and calendar of events. Unless there are valid reasons to the contrary, travel lanes should not be reduced in number or width, nor work be permitted to interfere with traffic, on weekends, holidays (including the PM peak the day before and the AM peak the day after) and days of special events of major traffic generators near the project site, such as the Meadowlands Complex and shore areas during the summer.
2. Using site visit and traffic count information, determine the number of lanes which can be closed during the day, during the night, or on weekends. Incorporate seasonal variations into the analysis. Contact the agency which has jurisdiction and ask what lane or road closings they will allow and discuss independent findings with them. With concurrence from the responsible agency, define the allowable lane closings (see Section 14.4).
3. Provide minimum lane widths of 11 feet for all lane shifts and diversionary roads, except where existing lane widths are 10 feet or as required in the Traffic Control Standard Details.
4. Determine if detour routes are available. If potential detour routes exist, determine if their use would enhance the constructability of the project.
5. Determine if shoulders or temporary pavements can be used by traffic. Shoulders may require reconstruction prior to placing traffic on them. Short temporary roads may provide access to other existing roads making a detour possible.
6. Determine if guide rail has to be removed or relocated. If removal of guide rail reveals a blunt end then temporary impact attenuators should be provided.
7. Determine if temporary signals are required.
8. Determine if there are any reasons why the construction project should be substantially accelerated when under construction. If there are reasons for an accelerated construction process, discuss proposed methods of implementation with the Department's Project Manager and the QMS Construction Scheduling and Assessment Section to determine the details of the acceleration (i.e. number of crews required, hours of work).
9. Using Preliminary Roadway Plans, determine the duration of the various construction operations required to build the project. Using this information, determine if lane closings can be set up and broken down over one work shift (8 hours±), over the weekend (Friday night to Monday morning), or must lane closings be maintained for longer continuous durations. All of the above may apply.
10. Determine whether or not Movable Construction Barrier should be used. Refer to Section 14.9.
11. Review the guidelines for nighttime construction described in Section 14.10.
12. Review the time allowed for the staging of paving operations. Determine that an appropriate amount of time is provided for sufficient curing, deck patching and/or cooling asphalt pavement.

14.6 Latex Traffic Stripes and Traffic Markings

Department Policy on Traffic Stripes and Traffic Markings are as follows:

1. Placement of TRAFFIC STRIPES and TRAFFIC MARKINGS may be delayed for up to 14 days after paving. Temporary pavement markers shall be used to delineate center and lane lines on newly paved sections of roadways that need to be opened to traffic prior to the placement of TRAFFIC STRIPES.
2. TRAFFIC STRIPES LATEX and TRAFFIC MARKINGS LATEX shall be used when traffic stripes or traffic markings are required on intermediate pavement layers that need to be opened to traffic due to stage construction and shall not be in place for more than 14 days. The traffic stripes shall be calculated in linear feet for each 4 inch width of actual stripe (gaps are not counted) under the item TRAFFIC STRIPES, LATEX. Chevrons, crosswalks, and stop lines shall be calculated in linear feet for each 4 inch width of actual stripe under the item TRAFFIC STRIPES SYMBOLS, LATEX. Words, arrows and other pavement symbols shall be calculated in square feet under the item TRAFFIC MARKINGS SYMBOLS, LATEX.

Temporary pavement marking tape and temporary pavement markers shall be specified when lane shifts are necessary on existing pavements not being repaved. The placement of temporary pavement markers shall be in accordance with the Construction Details. However, the designer shall specify TRAFFIC STRIPES and TRAFFIC MARKINGS rather than temporary pavement marking tape and temporary pavement markers when the usage of the placed material would extend beyond December 21st.

When traffic stripes/markings are removed to accommodate stage construction, the removal process invariably mars the final surface. Marring is allowable on intermediate layers, however, the final surface course must not be marred.

Designers are to design the project in such a way as to ensure the final surface course does not require temporary traffic stripes or markings to be removed, or develop additional quantities for milling and paving of the final surface course marred by the removal of traffic stripes or markings.

3. TRAFFIC STRIPES or TRAFFIC MARKINGS may be considered for stage construction, detours, and diversionary roads on those occasions when it can be justified based on cost considerations, site conditions, or length of time when the stripes or markings will be in place. It is important to estimate the length of striping based on all of the above factors of a project.

14.7 Lane and Roadway Closures

14.7.1 Lane Closures

Designers should modify standard sheet TCD-1 to provide a table showing specific restrictions placed on travel lanes, durations of closures and hours when work may be performed, including holidays and weekends. The closures and lane restrictions shall be evaluated in the Traffic Impact Report (see Section 14.4) and approved by the Regional Traffic Operations and Local Authorities. The following table is provided as an example of the form of presentation of this information:

Roadway Route Designation and Direction	Type of Closure	Monday thru Thursday	Friday	Saturday	Sunday
	No Closure				
	One Lane Closure				
	Two Lane Closures				
	Full Closures (indicate duration and type of operation)				

14.7.2 Total Roadway Closures

Total roadway closures (i.e. all lanes, single direction or two directions) required for the erection of overhead sign structures, cantilevered sign structures or bridge steel shall be performed in accordance with the following:

- The use of total roadway closures shall be specifically addressed in the Traffic Impact Report (see Section 14.4) and shall be considered only after detours have been determined to be unavailable or infeasible.
- Closures shall be approved by the Regional Traffic Operations and Local Authorities.
- Closures shall be performed during non-peak hours and with prior approval of the Engineer concerning the timing and method of operation.
- The application of nighttime operation of the closure shall be considered (see Section 14.10).
- The erection of overhead and cantilever sign support structures shall be done when the overhead electric lines have been de-energized.
- Closures shall be initiated with a slowdown of traffic 1/2 mile in advance of the work area. The slowdown shall be accomplished with the assistance of Traffic Direction, Police.
- Closures, whether single direction or two directions, shall be limited to 15 minute intervals. At the end of each 15 minute interval the work must stop, the span must be secured and traffic allowed to pass. After traffic has cleared, the roadway may again be closed for another maximum 15 minute interval (following the procedures in this section) and work may resume. Continue this procedure until all work over the roadway is complete.

14.7.3 Center/Interior Lane Closures

Existing roadway facilities with three or more lanes in each direction often require the closure of interior lanes to perform construction activities. The Standard Traffic Control Details TCD-16, "6 Lanes, Divided, Two Lane Closing" and TCD-17, "6 Lanes, Divided, Center Lane Closure, Maintain Two Through Lanes" provide two methods for maintaining traffic during construction in an interior lane. The functional difference between these two details is the number of through lanes that remain open after the closure is setup and that TCD-17 is to be used only when workers are not present. In general, TCD-16 is the preferred method for closing an interior lane when the open lane has the capacity to carry the traffic. In addition to this general guideline, specific project/site conditions should be evaluated when determining the appropriate use of these details.

The decision to use TCD-17 should consider capacity and safety along with the following:

1. Determine if the lane closing is for the short term (one day) or long term.
 - The lane closure layout shown on TCD-17 is intended for short term use and only when workers are not present.
 - A buffer space should be used at the upstream end of the closed interior lane. For long term operations a barrier should be used to shield the operation in the closed interior lane.
 - If barriers are used, sufficient room must be provided for the placement of end treatments.
 - If barriers are not used, a TMA/arrowboard equipped vehicle should be used at the beginning of the interior buffer. If the work operation moves more than 150 feet from the buffer zone, a TMA equipped shadow vehicle should follow the work operation.
 - For long term operations, solid white lines should be used in the two lane section. DO NOT PASS signs may also be used.
2. Determine the type of activity, size of construction equipment and worker proximity to travel lane. If barriers are not used, work should not be conducted within 1 ½ feet of a live travel lane.
3. Determine if there is adequate distance to establish the lane closures. Consider volume, speed and road alignment.
4. Determine if there is an exit within the work zone area.
 - Establish whether the closure should be from the right or left lane and determine the type and location of signing (i.e. a right lane exit should use a left lane closure, in this way the right lane will be continuous and the signing will direct exiting traffic to keep right).
 - When TCD-17 is used and an interchange is located either within the limits of the closure or within ½ mile of the end of the closure, temporary guide signs indicating "All Exiting Traffic Keep Right (Left) must be placed on both sides of the roadway as follows: 1300 feet before sign W20-1D, "Road Work ½ Mile" and 500 feet before sign W20-5A, "Right (Left) Lane Closed 1500 Feet".

- TCD-17 should not be used when multiple interchanges occur within the limits of the closure.
5. Determine if shoulders can be used in conjunction with TCD-16 to increase capacity in lieu of TCD-17.

Applications

The use of Standard Detail TCD-17 should be limited to projects and roadway conditions where a greater benefit can be attained than if TCD-16 were used. Listed below are examples where the use of TCD-17 should be considered:

1. Bridge rehabilitation projects.
2. TCD-17 can be used as a valve to provide increased capacity by intermittently controlling the use of one or two through lanes.
3. Sign structure and sign repair projects (i.e. changing the existing sign on an overhead sign structure where working on the catwalk is not feasible).

14.7.4 Alternate Traffic Routes

1. General

Alternate traffic routes located where high approach speeds are anticipated should be of a high-type design. Transition lengths, curve radii, superelevation and other design features should be consistent with the speed of traffic that will be entering the alternate traffic route.

2. Diversionary Roads

If a temporary roadway is to be constructed on State right-of-way or easement as part of the contract to carry traffic around a construction site it should be referred to as a "diversionary road" and not an official detour. It is desirable that diversionary roads used for construction zone traffic control have the same design speed and cross section as the existing roadway. The minimum design speed of the diversionary road shall be 20 mph less than the design speed of the existing roadway.

3. Detours

An official detour exists whenever, as a result of State Highway construction, existing roadways are to be closed temporarily and it becomes necessary to reroute State Highway, Municipal or County Road traffic over other existing streets or roads to maintain the normal flow of pedestrian and vehicular traffic.

Even though the Department is not legally required to obtain County or Municipal permission to close down roads or streets because of State Highway construction and designate other roads and streets for detours, it is the Department's policy to meet with the proper authorities and to try to obtain their permission and cooperation beforehand.

The roads or streets to be used for the detour should be examined to make sure they are acceptable from the standpoint of condition, safety, necessary signing, lighting and repair. A detour map, together with recommendations for signing, repair, limitations, if any, should be prepared and submitted as part of the project design. Approval of the project makes the detour "legal" and also sets up funds

for the improvement, maintenance and repair that are required. The Department is required by Statute to obtain prior permission to improve Municipal streets.

The Department is responsible for all of these arrangements. Should situations of this type exist which are not being handled as described, the Department's project manager should immediately be contacted so that proper action can be taken.

4. Haul Roads

The local roads which the Contractor uses to transport materials for the construction project. Haul roads are not considered detours. Municipalities may not levy charges against the haul vehicles because they are licensed to travel on any road in the State.

14.7.5 Temporary Emergency Pull-Off

Emergency pull-offs serve as areas of refuge for disabled vehicles. Typically, they should be utilized on Interstate, expressway and freeway projects exceeding one mile in length when construction activities result in the loss of shoulders for durations exceeding three months. A shoulder is considered lost where it is unavailable due to its being utilized as a lane or a work zone.

Locate emergency pull-offs directly adjacent to the right side of the roadway at approximately one-half mile intervals. Their location should allow for the required minimum stopping sight distance to be met, including stopping sight distance on vertical and horizontal curves. Where feasible, select emergency pull-off locations to avoid adverse impacts to environmentally sensitive areas, utilities, beam guide rail, grading, etc. Modify existing or provide temporary beam guide rail adjacent to emergency pull-offs if warranted (refer to Section 8). Supply a list of the proposed emergency pull-off locations, along with a detail on the Traffic Control Plans and account for the proposed signing, temporary pavement, removal of temporary pavement, and other associated work items. If the roadway geometry does not lend itself to providing minimum standards, engineering judgment should be applied in locating the pull-off areas.

The minimum length of a pull-off area should be 300 feet long plus the taper length. The full width of the emergency pull-off from the edge of travel lane should utilize the same criteria as outside shoulder widths in Section 5.4.2. However, it is desirable that it is 12 feet. For pull-offs less than 11 feet wide, adjacent guide rail should be offset to allow passengers to exit the vehicle. Where a high cut or fill exists, provide a 6 foot vertical curve outside the emergency pull-off. When necessary, construct temporary pavement for the emergency pull-off area (e.g. instances when an existing outside shoulder is utilized for traffic staging). The temporary pavement will need to be removed after the emergency pull-off is no longer necessary. When an existing outside shoulder is taken out of service, sections of that shoulder may temporarily be used to serve as emergency pull-off areas. The typical emergency pull-offs layout is shown in Figure 14-B. To avoid the need for crash cushions, the departure taper may be lengthened.

14.8 Construction Barrier Curb

14.8.1 Introduction

In general, Construction Barrier Curb should be installed only if it is clear that the barrier offers the least hazard potential. Elimination of the warranting obstruction

should always be the first alternative considered. Limiting excavations to that which can be backfilled the same work shift or covering minor excavations are practical examples of how obstructions, commonly encountered during construction, can be eliminated. In some cases, a detour may be the most practical solution, especially on projects that would require large quantities of construction barrier.

When construction barrier is not warranted, other traffic control devices such as cones, drums and breakaway barricades are still warranted.

There may be situations where there is not a clear choice as to whether or not a construction barrier is warranted or where site conditions or construction operations will exclude the use of a construction barrier even though one is warranted. The designer should constantly be on the lookout for situations where the site conditions and/or the operational characteristics of the road such as adverse geometrics, high operating speed and high traffic volume, will make the use of construction barrier appropriate even though not specifically required by the warrants shown in the next subsection. Such cases should be evaluated on an individual basis and, in the final analysis, must usually be resolved by engineering judgment. In such cases, adequate documentation should be included in the job file so that whatever action is taken cannot be misconstrued as being arbitrary.

14.8.2 Warrants

The following guidelines are to be used to establish warrants for using Construction Barrier Curb when developing Traffic Control Plans. Three factors must be considered in determining if an obstruction warrants a construction barrier:

- The physical characteristics of the obstruction.
- The distance from the traveled way to the obstruction.
- How long the obstruction will exist.

For an obstruction to warrant a construction barrier, all three of these criteria must indicate that a barrier is needed.

Physical Characteristics: A warranting obstruction is defined as a nontraversable roadside or a fixed object which is located within the clear zone and whose physical characteristics are such that injuries resulting from an impact with the obstruction would probably be more severe than injuries resulting from an impact with construction barrier.

See Section 8.2.4, "Warrants", for examples of fixed objects and nontraversable hazards whose physical characteristics are such that they may warrant a construction barrier.

Also, other examples of using construction barrier to protect vehicles from warranting obstructions are:

- To protect traffic from entering work areas such as excavations.
- To protect construction such as falsework for bridges and other exposed objects.
- To separate two-lane, two-way traffic on one roadway of a normally divided roadway. Whenever two-way traffic is to be maintained on one side of a normally divided highway, opposing traffic shall be separated as follows and such separation shall be shown on the Traffic Control Plan.

Where the TL TWO is used, the TCP shall include the above provisions for the separation of opposing traffic except:

- A. Transition Zones - Positive Barrier (Pre-cast Concrete Construction Barrier Curb or approved alternate).
- B. Between Transitions - Positive Barrier, as described in A above or by delineation devices, such as drums, cones or vertical panels, as deemed appropriate by the Design Unit and with the concurrence of the Bureau of Traffic Signal and Safety Engineering.
- C. Striping and complimentary signing shall be used in conjunction with A and B above.

Distance from the Traveled Way: An obstruction within the clear zone may warrant a construction barrier. The clear zone is the area, starting at the edge of the traveled way, available for safe use by errant vehicles. See Section 8.2.3, "Clear Zone", on directions on how to determine if an obstruction is within the clear zone.

Duration of Existence: A construction barrier may be warranted if an obstruction will remain within the clear zone for more than one work shift.

14.8.3 Applications

Construction Barrier Curb, is shown on Construction Detail Sheets CD-159-3, CD-159-4 and CD-159-5. Alternate A can be pinned to the roadway, and Alternate B has pockets to receive 1 inch diameter anchor bolts as well as pin holes.

There are three types of connections. Connection Type A should only be used at those locations where an allowable movement of the barrier, when hit, of 41 inches is acceptable. When the maximum allowable movement is 28 inches, connection Type B should be used. When the maximum allowable movement is 11 inches, connection Type C should be used. The connection type to be used at specific locations should be indicated on the Traffic Control and Staging Plans.

Connection Type B uses a box beam bolted onto the construction side of the barrier to help reduce deflections. Refer to Construction Detail sheet CD-159-3. The box beam side cannot be placed adjacent to traffic due to the potential snag hazard.

Construction Barrier Curb stiffened with box beams shall be installed at least 50 feet prior to, be continuous through, and extend at least 50 feet beyond the area requiring limited deflection. Show limits on Traffic Control Plans.

There is an optional Connection Type B treatment at vertical drop off (edge of bridge, edge of vertical cut, etc.) shown in Standard Traffic Control Detail TCD-2. It allows for the barrier to extend over the edge of a vertical drop off after it is hit. For Connection Type B, according to the crash test, the center of gravity (centroid) of the barrier sections was deflected beyond the edge of the vertical drop off. However, its connection to the other sections prevented it from falling off. Therefore, barrier with Connection Type B may be placed a minimum 12 inches from the edge of the vertical drop off, provided there is at least 28" of clear space beyond the barrier. For example, if the outside edge of the barrier was placed 12 inches from the edge of the bridge drop off, the bridge area behind the barrier (12 inches) plus an additional 16 inches (28" - 12") past the drop off must be clear of all obstructions (utility poles, scaffolding, equipment, materials, etc.) or people. The optional Connection Type B treatment at vertical drop off will be used where there is not enough room to allow all of the maximum allowable movement in front of the vertical drop off and detours are

not feasible. Reduce lane widths and shoulder widths to the minimum allowed during the construction stage in question, prior to considering the optional connection treatment.

The following chart summarizes the respective connections:

Connection Type	Use	Connections
A	Maximum allowable deflection of 41 inches	Connection Key, and barrier end sections fully pinned*
B	Maximum allowable deflection of 28 inches (Cannot be used with traffic on both sides of the barrier.)	Connection Key, 6" by 6" box beam, and barrier end sections fully pinned*
C	Maximum allowable deflection of 11 inches	Connection Key, construction side of all sections pinned, and barrier end sections fully pinned*

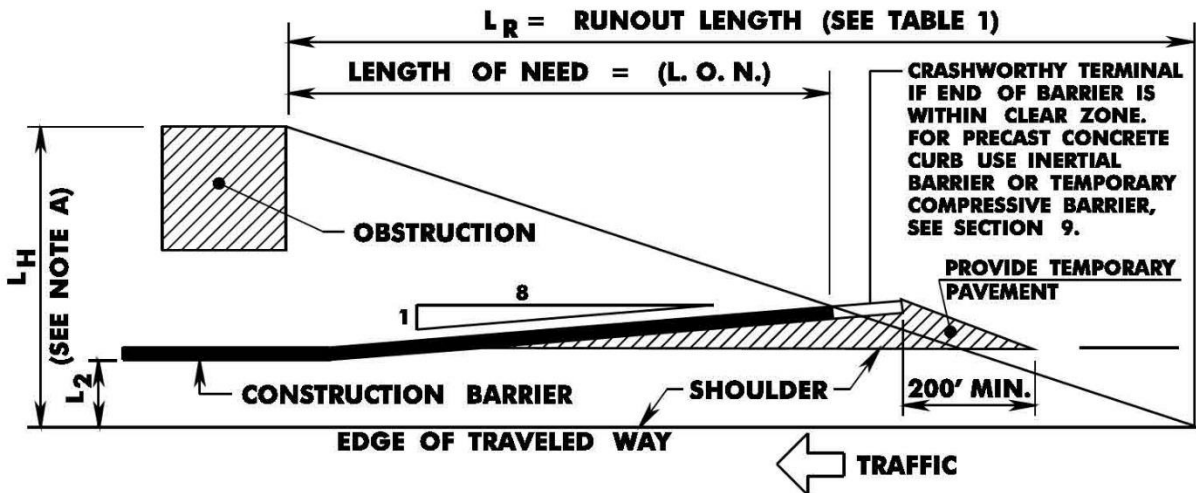
* Fully Pinned: pins in every anchor recess on both sides. End Sections: The first and last barrier piece of the entire run regardless of connection type.

Pinning barriers to a new bridge deck is undesirable. Pinning barrier to a bridge deck that has an existing LMC overlay undermines the effectiveness of the LMC. In addition, the extra costs associated with placement of LMC make it especially undesirable to lessen its effectiveness by drilling holes through it. Designers are advised to investigate alternatives in order to eliminate the need for pinned barrier on bridge decks where possible so as not to compromise the benefits of the LMC overlay. As an example, if sufficient additional lateral room can be gained, this will eliminate the need for a pinned Construction Barrier Curb.

Construction Barrier Curb shall not be installed on side slopes steeper than 10H:1V. The approach end shall either be flared at 8:1 beyond the clear distance or, when terminated within the clear zone, the approach end of the barrier shall be shielded. See Section 9 for design of inertial barriers or temporary compressive crash cushions.

The minimum functional length of Construction Barrier is 100 feet. Construction Barrier Curb comes in units of 20 feet length, however, other lengths may be used to meet field conditions, see nominal lengths in the Standard Construction Details. The approach length of need (L.O.N.) is the minimum length of construction barrier required in front of the warranting obstruction to shield the hazard effectively. See Figure 14-A for instructions on how to determine the L.O.N. of a Construction Barrier Curb.

FIGURE 14-A: LENGTH OF NEED OF CONSTRUCTION BARRIER CURB



DESIGN SPEED (M.P.H.)	TRAFFIC VOLUME (A.D.T.)			
	OVER 10,000	5,000-10,000	1,000-5,000	UNDER 1,000
70	360	330	290	250
60	300	250	210	200
55	265	220	185	175
50	230	190	160	150
45	195	160	135	125
40	160	130	110	100
30	110	90	80	70

NOTE A: If obstruction extends beyond Clear Zone, make L_H equal to Clear Zone, except if obstruction is a Critical Slope, see Figure 8-H.

NOTE B: If Roadway is curved, draw layout to scale and obtain L.O.N. directly by scaling from drawing.

NOTE C: If barrier end is parallel to Roadway (no flare), then change "1/8" in formula to "0".

NOTE D: When using Connection Type B, the LON is the greater of 50' long or the calculated taper length.

EXAMPLE

$$L.O.N. = \frac{L_H - L_2}{\frac{1}{8} + \frac{L_H}{L_R}}$$

$$L_2 = 15'$$

$$L_H = 25'$$

$$L_R = 360'$$

$$L.O.N. = \frac{25 - 15}{\frac{1}{8} + \frac{25}{360}}$$

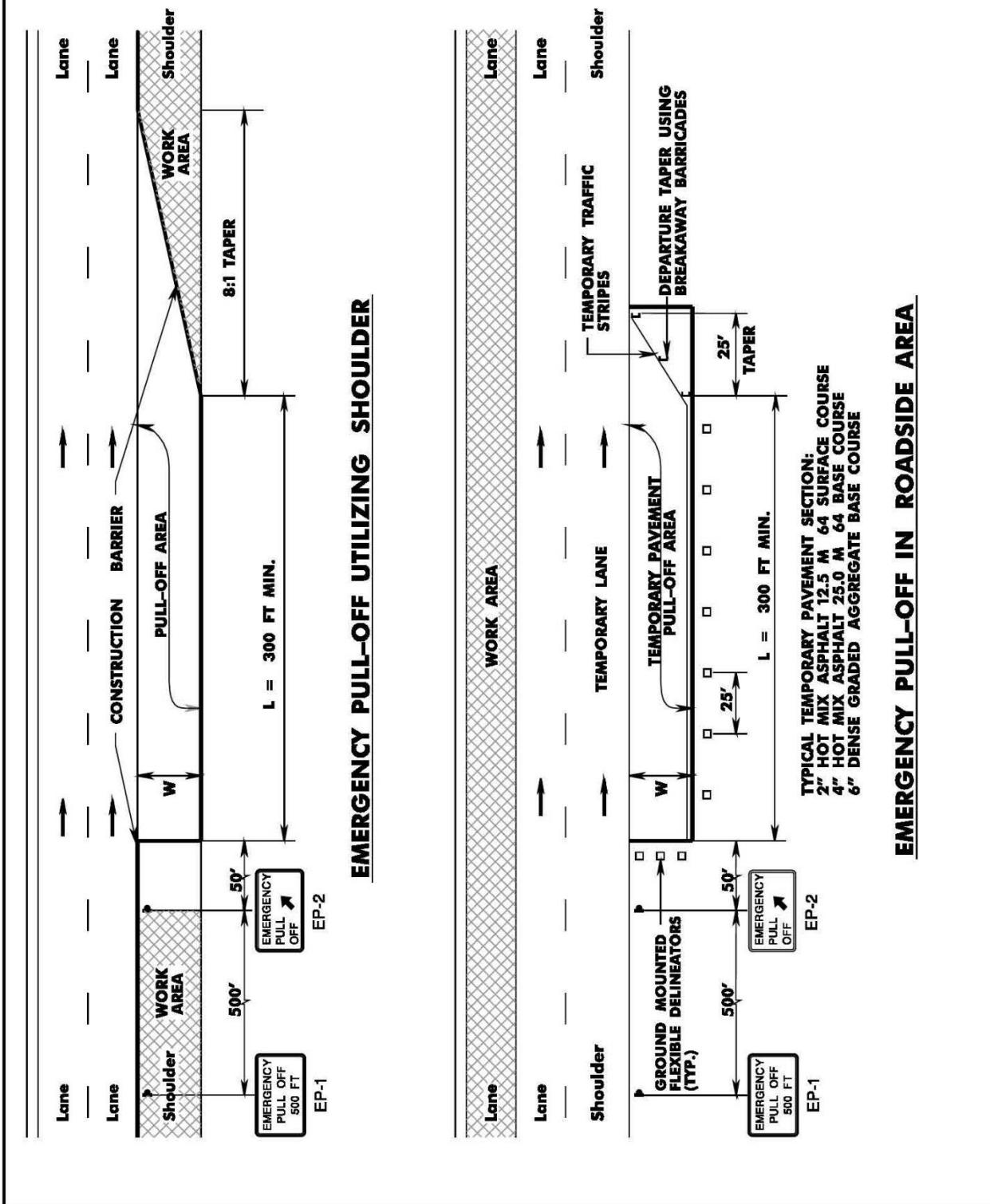
DESIGN SPEED = 70 mph
ADT = 26,000

L.O.N. = 51.4', increase to nearest multiple of 20', therefore L.O.N. = 60'

SOURCE: AASHTO "ROADSIDE DESIGN GUIDE", 4TH EDITION 2011

REV. DATE: JUNE 30, 2015

**FIGURE 14-B:
TEMPORARY EMERGENCY PULL-OFF**



REV. DATE: JUNE 30, 2015

14.9 Construction Barrier Curb, Moveable System

14.9.1 Warrants

The following guidelines are to be used to establish the warrants for using Construction Barrier Curb, Moveable System (CBM) to achieve an efficient and effective Traffic Control Plan. CBM will provide additional traffic capacity lanes for accommodation of both AM and PM peak traffic, a safe and expeditious means of expanding the Contractor's work area (all work is done using positive separation), or the opportunity to stage projects in a more efficient method.

CBM's should be a type that can be quickly moved laterally from 4 feet to 18 feet in one continuous operation and at speeds of about 5 mph. The decision to use a CBM system should be made by the designer with capacity, safety and economics as the guidelines and should include the following considerations:

1. Additional traffic lane capacity can be gained during peak hour traffic periods.
2. Additional contractor working area can be gained during off peak hours and s
3. Construction time can be shortened either through staging or increased productivity by the contractor.
4. Timing required to set up staging can be kept to a minimum.
5. Construction sites with limited work zones in urban or restricted areas where frequent day or nighttime lane closures will be required.
6. Their use will provide a greater degree of safety for motorists.
7. Projects which are located in non-attainment areas and Clean Air Issues require a reduction in emissions.

Input for justification should be obtained from the Bureau of Traffic Engineering and Regional Construction.

14.9.2 Applications

When developing the Traffic Control Plan, the use of these CBM systems should be limited to projects where a greater benefit can be attained than if standard methods and equipment were used. Listed below are types of projects where it would be a viable option for use.

1. Widening or reconstruction projects on highways or expressways with high peak hour traffic volumes (i.e. 50,000 AADT and greater for four lane facilities and 90,000 AADT and greater for 6 lane facilities).
2. Projects where a reversible traffic lane would be beneficial during peak traffic durations and which would allow for better staging.
3. Median and shoulder reconstruction projects. Examples include shoulder/median improvements or widenings, such as a new permanent concrete barrier being installed. The CBM is especially beneficial when the size of the work zone is either very restricted or if repeated lane closures are anticipated.
4. Resurfacing projects. By closing one side of a divided highway and creating opposing traffic lanes on the open side of the road, a contractor can resurface one side of the roadway at night without interference from traffic.
5. Reconstruction of parallel structures. Design of a reversible lane to increase the capacity of one structure while closing down the other.

6. Alternate routes do not have excess capacity for suitable detour.
7. Alternate routes do not exist.

14.9.3 Safety and Cost Considerations

In construction projects, the CBM generally is used to open traffic lanes during peak traffic periods and close the lanes during off peak periods to allow improved access to the work zone. In this application the CBM has the unique ability to provide continuous positive protection before, during and after the opening and closing of traffic lanes. Once these barriers are on the road, it takes significantly less time to perform a lane closure with this barrier than it does using traditional methods. A determination should be made by the designer that this feature and resulting increased worker safety makes the use of the CBM system a viable alternative to conventional traffic control devices. Its use should be clearly described in the Traffic Control Plan.

When considering this product the designer should also prepare a cost comparison of the CBM and the next best alternative. The following items should be considered:

1. Cost of the CBM. The designer should work with the supplier to determine operational costs and a lease price to contractors.
2. The next best alternative and its cost.
3. If possible, the accident cost savings associated with the use of the CBM and the next best alternative. It is assumed that there is no difference in accident costs when CBM is compared to construction barrier curb of other types.
4. The savings in time for the projects schedule should also be considered with the overall savings.
5. Consideration for congestion and clean air issues where a reduction in emissions is required.

Use of CBM on land service roads should take into consideration access to properties and businesses. Access must be maintained during construction.

When using CBM, consideration for additional wide load signing in the Traffic Control Plans may be appropriate. If the barrier is used to reverse traffic flow and there is a single lane in one direction, it shall not be less than 11 feet.

CBM should only be used on tangent sections and flat curves where an angle of impact of not more than seven degrees exists and where an allowable movement of the barrier, when hit, of 1 ½ feet is acceptable. The CBM can be used on the following sharp curves where an allowable movement of the barrier, when hit, of 5 feet is acceptable:

Number of Lanes	5 ft. Deflection where Radius is less than
1	500 feet
2	900 feet
3	1300 feet

Approved safety end treatments for Inertial Barriers and temporary compressive barriers see Section 9. Where possible, the barriers may be tucked behind conventional concrete barrier curb. See Section 9 for construction detail requirements for Inertial Barriers and temporary compressive crash cushions.

14.10 Nighttime Construction

In keeping with the Department's mission of delivering a safe, reliable and affordable transportation system and to alleviate traffic congestion and improve air quality, it is proposed that any activity that requires the temporary closing of traffic lanes which results in a sufficient degradation of the highway level of service, should be performed at night provided that certain conditions outlined below are met. Excluded will be emergency operations such as: locations where safety conditions preclude nighttime work; locations where existing municipal ordinances have been enacted that prohibit nighttime work; or locations where the traffic volumes are such that the work activity can be accomplished during the day without significant negative impacts.

It is the intent of the Department to perform construction activities at night that would otherwise cause unacceptable negative impact on traffic flow. It is recognized that there are certain influencing factors that must be reviewed when considering whether or not to perform nighttime work.

The decision to perform nighttime work will be determined during the scoping process but the final approval for nighttime construction should be made by the Department's Project Manager. The following guidelines are to be used for establishing the warrants for nighttime work.

1. The conditions listed below must be met before nighttime work can be performed:
 - Compliance with local noise restriction ordinances.
 - Office of Community Relations has obtained local government approval for nighttime work within the project limits. (Inform local government of what type of work will be taking place.)
 - Work zone safety must not be compromised by nighttime construction activities.
 - The quality of construction work must not be compromised by nighttime work.
2. Some factors that may eliminate the need for nighttime work:
 - A shoulder which may be used in place of the lane to be closed.
 - A viable detour is available.
 - Traffic Operations staff and the Traffic Impact Report indicate that a lane closure during the day would not cause a significant impact.
3. Projects which may require both day and nighttime construction operations are as follows:
 - Projects where the location has specific seasonal requirements (such as shore routes during the summer, major shopping centers at the Holiday Season).
 - Projects where the work required has specific temperature or environmental constraints.
 - Projects with accelerated construction schedules.

14.11 Construction Details

Construction details should be provided for any traffic control device not adequately covered by the Standard Roadway Construction Details.

14.11.1 Crash Cushions

Crash cushions in construction zones shall not be placed on side slopes steeper than 5%, or on islands, curbs, platforms, etc. greater than 4 inches in height. Designers should refer to Section 9 - Crash Cushions for information on the design of the temporary compressive barrier crash cushions and Inertial Barrier systems. The designer must provide design specific information such as the required number of bays or modules for each location. For Inertial Barrier systems, a layout of the modules including the weight of each module shall be included as a construction detail in the contract plans.

14.11.2 Signs

1. General

- Any construction sign not depicted on the Standard Roadway Construction Details should be shown in detail.
- "Trail blazers" should be sized relative to the posted speed limit (i.e. use 4 by 3 feet for posted speeds greater than 40 mph).
- Determine if specific site conditions require special supplemental signing. The use of variable message boards should be considered and approved by Regional Traffic Operations.

2. W99-2 Signs

All projects should include provisions for construction signs with the legend "GIVE US A BRAKE - SLOW DOWN". These signs should be designated as W99-2 and should be 4 by 4 feet. The following guidelines should be used for determination of location and quantity of W99-2 signs:

- Signs will be located 200 feet in advance of the project, one sign for each direction of traffic flow.
- Signs will be installed on existing highways within the scope of the project.
- Signs are to be installed in accordance with the Standard Detail for Construction Signs.

The W99-2 signs are now eligible for Federal-aid funding participation.

3. Construction Identification Signs

Construction Identification Signs should be included in all projects. The following guidelines should be used to determine the location and quantity of Construction Identification Signs:

- Signs are to be located in advance of the project, one sign for each direction of traffic flow.
- Signs are to be installed on major existing intersecting highways within the limits of the project.

4. Tables for Construction Signs

In order to estimate the required quantity of signs in square feet, designers should prepare a summary of signs for the project. This summary of construction signs should be shown on a table, and included on the first sheet of the Traffic Control Plans. An example of a completed table listing the sign designation, quantity and area in square feet is shown on TC-1 of the Sample Plans.

14.11.3 Guide Rail

Guide rail in construction zones shall not be installed on side slopes steeper than 10H:1V. Otherwise, guide rail shall be used in construction zones in accordance with Section 8, "Guidelines for Guide Rail Design and Median Barriers".

14.12 Utilities

Utility relocations that affect staging or traffic control should be clearly identified on the staging and traffic control plans. This information should include both temporary and permanent relocation work. Notes pertinent to the relocations should be provided on the applicable staging plan(s) and/or traffic control plan(s). In addition, the designer should review the need for general utility notes to be added or modified on TCD-1.

14.13 Quantities

Quantities should be estimated based upon actual usage/requirements shown on the plans.

For quantity purposes, the If and Where Directed number of units or linear feet of traffic control devices and signs should be the maximum quantity required to be in use at any one time. Construction signs should be tabulated by sign designation, quantity and area in square feet (see Section 14.11.2). Signs indicating speed limits or speed reductions should be included.

Temporary pavement to be used for traffic control should be shown as plan sheet quantities. Quantities for the removal of temporary pavement must also be considered. Standard Item Numbers with construct quantities and a TO BE CONSTRUCTED box should be shown on the Traffic Control and Staging Plans where temporary pavement is to be constructed or removed.

14.14 Installation and Removal Sequence for Work Zone Traffic Control

The manner in which traffic control schemes are installed and removed may affect safety and traffic flow. The following is a suggested guideline describing the proper installation and removal sequence for work zone traffic control schemes:

1. Required advance warning signs should be installed first so that protection is provided when channelizing devices are installed near the work area. If work zone signing is necessary for both directions of travel, sign installation should begin with the advance warning sign located furthestmost in advance of the work area and on the side of the roadway opposite the work area. Sign installation should proceed down the roadway toward the work area. After the necessary signs are erected on the side of the roadway opposite the work area, sign installation may begin for the other direction of travel, beginning with the sign furthestmost from the work area. In the process of installing the work zone signing, existing signs with conflicting messages shall be completely covered, removed or modified.
2. If the work area is such that flagging operations are necessary, the flaggers may begin flagging operations after the advance warning signs are in place. Otherwise,

the installation of channelizing devices at the work area can begin after the placement of the advance warning signs. These devices should also be installed in the direction of travel starting with the device furthestmost in advance of the work area.

3. A shadow vehicle with a TMA should be placed between approaching traffic and the workers who are installing channelizing devices around the work area. After the channelizing devices are installed, the vehicle may be removed or moved inside the work area and the work may begin.
4. After work is completed, the work zone traffic control scheme may be dismantled. The removal of the traffic control scheme should be carried out in reverse order from the installation procedure. The channelizing devices which surround the work site should be removed first, followed by flaggers which may have been used. The work area signing may then be removed and normal traffic patterns restored.

14.15 Traffic Control Plan Submission Requirements

14.15.1 Initial Submission: Investigate project site specific conditions and Prepare Preliminary Staging Plans:

1. Visit project site and note locations of the following:
 - Horizontal and vertical sight distance restrictions due to existing roadway conditions (i.e. roadside vegetation, adjacent property usage, overpass bridge structures, sign structures, barrier curb, guide rail and/or horizontal and vertical geometry).
 - Expected pedestrian activity, crosswalks, parks, schools, bus routes, school bus routes, bus stops, emergency vehicle access routes, churches, stadiums, and/or shopping and industrial areas. When a park is located within the project limits, obtain a calendar of events and the name, address and phone number of the individual to contact for coordination of construction staging. Also obtain University calendar events where applicable.
 - Existing emergency facilities for fire, rescue and/or police; where traffic signals exist, note if they are equipped with an optically controlled emergency vehicle detection system or a pre-empted system to provide for clearance of adjacent railroad crossings.
 - Look for alternate routes which can be used as detour routes.
2. Review of Existing Information
 - Review as-built plans and/or collect field data necessary to determine the horizontal and vertical sight distances of the existing roadway throughout the project limits including 1,000 feet beyond each terminus.
 - Obtain existing peak hour traffic counts with vehicle classification and 24 hour ATR traffic counts. Use this data to support decisions regarding minimum lanes to be maintained, detour requirements and work hours.
 - Review existing accident information to determine if any specific type of vehicle accidents may affect the proposed staging plans.
 - Determine if the traffic flow within the project area has any seasonal characteristics such as shore route, Christmas shopping route, etc.

- Determine the agencies which have jurisdiction over the project area and potential detour routes.
3. Prepare Preliminary Roadway plans in accordance with current submission requirements. Note features that will effect traffic control such as number of lanes and lane widths, existing shoulder widths and pavement thickness, lateral clearance restrictions, vertical and horizontal clearances at structures, structural widths (i.e., parapet to parapet, abutment to abutment, stringer spacing, etc.) and the location of major utilities.
 4. Prepare Preliminary Staging Plans to show the overall approach to the required stages of construction of the project considering site specific conditions and work to be accomplished. Identify issues, constraints and time frames associated with the various stages to be studied in greater detail during Final Design.
 5. Prepare a Traffic Impact Report as discussed in Section 14.4 above.
 6. Contact and coordinate with appropriate State Highway Authorities (i.e. New Jersey Turnpike, Garden State Parkway, Atlantic City Expressway, etc.) to obtain the required permits needed to enter upon lands under their jurisdiction. This coordination effort should include, but not be limited to:
 - Permits required and fees.
 - Authorities Traffic Control Plan Standards.
 - Insurance requirements.
 - Materials specifications.
 - Agreements between NJDOT and affected Highway agency to perform certain type of work.

14.15.2 Final Submission: Prepare Final Traffic Control Plans and Staging Plans:

1. Perform field visits and collect additional field data as necessary during the development of the Final Traffic Control Plans and Staging Plans.
2. The first two sheets of the Traffic Control Plans should be Standard Traffic Control Plan sheets TCD-1 and TCD-2 modified to address project site specific conditions. This sheet should contain General Notes, a Standard Legend of typical traffic control devices and a table showing recommended spacing of the channeling devices if project specific traffic control plans have been added to the contract plans.
3. Review the Traffic Control Details, select details applicable to the project and modify to reflect the specific site constraints and construction procedures required to construct the project.
4. Review the Legend and modify to include other project specific symbols as necessary for traffic control.
5. Review the need for travel lane restrictions.
6. Review hours of operations or lane restrictions determined in the Initial Submission, consideration should be given to the location of the project, calendar of events, etc.

7. Review the Traffic Control Detail General Notes and select the notes applicable to the project. Additional project specific notes should be added as necessary. The notes should include but not be limited to:
 - specific restrictions placed on travel lanes,
 - durations of closures,
 - hours when work may be performed (include holidays and weekend hours),
 - number of lanes of unobstructed traffic to be maintained in each direction,
 - staging of traffic signals,
 - temporary drainage,
 - allowable minimum widths of traveled way and if detour routes have to be established for over width vehicles,
 - number of lanes to be open to traffic,
 - diversionary routes with any restrictions,
 - traffic lanes or patterns to be maintained during construction for local roads affected by construction,
 - contractor's access and staging areas,
 - provisions for maintaining access to driveways,
 - signing for temporary access driveways to commercial developments.
8. Standard sheets TCD-1 and TCD-2 can be modified to include other project specific information necessary to adequately address traffic control needs as follows:
 - Where required for clarification, sectional views showing the placement of traffic control devices, such as construction barrier, adjacent to the traveled way and the work site should be provided.
 - When ramps or jughandles are to be reconstructed, consideration should be given to the effect that the work will have on traffic patterns or flow. Traffic Timing Plans for traffic signals may have to be altered.
 - The need for a detour route should be considered if a ramp or jughandle is to be closed for construction. Also, where work is to be performed on a ramp or jughandle whose width is less than 14 feet, that ramp or jughandle should be closed while the work is being done or if the ramp cannot be closed, a temporary ramp widening may be required. When reconstructing a shoulder, consider the use of a temporary traffic shift to provide a buffer.
9. Following standard sheets TCD-1 and TCD-2, prepare additional Traffic Control Plans to show plan views of project specific work sites when these locations need to be represented or where design features of traffic control devices or temporary pavement markings need to be indicated. Issues to address on the plans should include but are not limited to those listed in Item 7 above. These plans should contain notes pertaining to the various stages of construction that thoroughly describe each phase of construction in the sequence to be performed. In addition,

utility relocations that affect the staging of construction should be clearly identified within the sequence of work.

10. When temporary pavement areas are required, a typical section should be provided.
11. Prepare and include in the Traffic Control Plans the method of removal of surface water runoff during each stage of construction.
12. Review the construction staging to determine any seasonal constraints due to weather (i.e. snow removal etc.).
13. Determine the constructability of the construction staging by reviewing the sequencing of work and methods of construction.
14. When staging the successive passes of resurfacing, consideration should be given to the location of the longitudinal pavement edge. Designers should avoid placement of these edges within the wheel path.
15. Determine if underground work (i.e. new storm drains, pipelines, gas, electric, etc.) is sequenced to coincide with or enhance construction phasing, and that this work will meet traffic control constraints for lanes, etc. (i.e. check limits on applying a back slope in trenches when calculating lateral clearances. Also check if sheeting or a trench box will be required. Standard segment lengths of pipe should also be considered.)
16. If required, prepare temporary or interim traffic signal plans, details and traffic signal timing plans associated with the staged reconstruction of existing traffic signals
17. Prepare construction details for any traffic control device not adequately covered in the Standard Roadway Construction Details such as the following:
 - Details for all Inertial barriers and temporary compressive crash cushions as per the construction detail requirements in Section 9 to be utilized on the project.
 - Construction signs not depicted in the Standard Roadway Construction Details.
18. Prepare and include in the Traffic Control Plans, a tabulation of the channelization devices needed for the project.
19. Obtain Traffic and Parking restriction ordinances approved by municipalities.
20. Establish a maximum length of lane closure, length of alternating traffic and maximum number of intersections affected.

14.16 Quality Control Checklist for Designers

Designers shall review the following checklist throughout the development of the Traffic Control Plans. Explanations are required for all "No's" checked.

Design / Quality Control	YES	NO
General		
Stage construction is required for the project and the proposed staging is constructible.		
A Traffic Impact Report was prepared.		
Warrants for nighttime construction have been evaluated.		
Nighttime construction is warranted and has been approved by the Department's Project Manager for use on this project.		
All staging designs and diversionary roads meet NJDOT Design and Construction Standards.		
All work zone pavement markings and traffic control devices meet MUTCD and NJDOT Standards.		
Adequate work zones and transitions are provided.		
Traffic Control Plans provide staging that facilitates construction phasing.		
Traffic Control Plans include NJDOT Standard Traffic Control Details that have been modified based on specific site constraints and construction procedures required to construct the project.		
The Legend and General Notes contained within the NJDOT Standard Traffic Control Details were reviewed, modified and/or expanded to address project specific conditions.		
Where required for clarification, sectional views showing the placement of traffic control devices, such as construction barrier, adjacent to the traveled way and the work site have been provided.		
Construction details for any traffic control device not adequately covered by NJDOT Standard Roadway Construction Details have been provided (i.e. temporary crash cushions).		
A tabulation of the channelization devices needed for the project is provided in the Traffic Control Plans.		
Temporary compressive barrier crash cushions are warranted, fill out summary table in CD-159-9		
Inertial barriers are warranted, include layout of modules, including the weight of each module as a construction detail.		
Appropriate designs, specifications and/or notes are provided for safety during work and non-work periods (i.e. storage of equipment, materials and vehicle parking outside clear zone, use of appropriate channelizing devices, etc.).		
Earthwork phasing is compatible with the actual construction and Traffic Control Plan for the project.		
The project makes appropriate use of the item, Traffic Director, Flagger.		
Emergency facilities for fire, rescue and/or police exist within the project limits.		
Special regulations are needed for speed limits, turn prohibitions, parking prohibitions and/or one-way designations.		
The hours of operation for this project (i.e. lane closures) have been established with Traffic Operations and are provided on the Traffic Control Plans.		

Expected pedestrian activity and crosswalks for parks, schools, residential, churches, stadiums, shopping, industrial and other appropriate areas have been identified within the project limits.		
A schedule of construction staging has been established to minimize interference with the timing of local events like shore traffic, county fairs, race tracks, sporting events, high volume traffic generators, etc.		
A park is located within the project limits and a calendar of events and the name, address and phone number of the individual to contact for coordination of construction staging is provided on the Traffic Control Plans.		
All pay items for temporary work are provided.		
Adjacent projects which may pose a conflict with traffic management during construction, including on parallel routes have been reviewed.		
All adjacent projects and/or agreements have been accounted for in the specifications.		
The completion date for this project has been reviewed in relation to area traffic management.		
The proper liquidated damages clauses are included for traffic management.		
Appropriate State Highway Authorities (i.e. New Jersey Turnpike, Garden State Parkway, Atlantic City Expressway, etc.) have been contacted and the required permits have been obtained in accordance with Section 14.15.1, 6.		
Detours / Diversionary Roads		
The project will require a detour.		
Resolution(s) of concurrence from the agency(ies) having jurisdiction over the detour route have been received and are on file with the designer and the Bureau of Traffic Signal and Safety Engineering.		
The appropriate Detour Plans are complete and presented correctly.		
Detour routes meet the minimum requirements to carry the volume and type of traffic detoured.		
The Traffic Control Plans and Specifications providing the required maintenance of traffic and/or work zones are completed and presented correctly.		
The temporary traffic signal timing and sequence is appropriate for the volumes projected to use the detour.		
Diversionary roads are required for the proposed stage construction and the design meets the minimum standards.		
The project specifications include provisions for videotaping the detour road before and after construction.		
Planned detour / diversionary road grades and existing ground contours appear to reasonably conform to the existing conditions.		
Temporary roadway/pavement design fits field needs.		
Detour / diversionary road grades coincide with crossroads elevations.		
Detour / diversionary road ends meet the existing or proposed alignment.		
Enough area is available inside the detour / diversionary road alignment to perform planned work.		
While the detour / diversionary road is in use, access for affected local business or residents is provided.		

Temporary striping is required.		
The cost of using temporary striping with latex versus long life striping was evaluated.		
Geometry		
The project site was visited and horizontal / vertical sight distance restrictions due to existing roadway conditions were identified (i.e. roadside vegetation, adjacent property usage, overpass bridge structures, sign structures, barrier curb, guide rail and/or horizontal and vertical geometry).		
The limits of construction have been extended based on field conditions (i.e. insufficient sight distance) at the proposed end limits.		
Required lane widths are shown for each staging plan.		
Minimum lane widths of 11 feet have been provided for all lane shifts and diversionary roads, except where existing lane widths are 10 feet or as required in the Standard Details.		
Constructability of the horizontal and vertical alignment was evaluated (i.e., widening on one side of the roadway may be more cost effective than widening on both sides because of physical restrictions).		
Widths of roadway widenings are compatible with equipment sizes (i.e. most placement/finishing units need widths of 12 feet to operate. Anything less becomes a grading tractor/hand labor activity with high costs).		
Roadway widths for projects which are not compatible with standard equipment sizes were avoided where ever possible (i.e. anything less than 10 feet -12 feet in width for base course becomes a grading tractor/hand labor activity. Asphalt paving machines usually have a standard screed width of 10 feet.		
Work zones have sufficient size for the intended construction operation (i.e. allow 30 to 36 inches for concrete paver tracks for work operations).		
Transition areas meet or exceed the minimum standards set forth in the MUTCD.		
Grading for all temporary roadways and cross-overs is shown.		
A maximum length of lane closure, length of alternating traffic and maximum number of intersections affected have been established.		
Pavement		
Temporary overlays or patching are needed for staging.		
Temporary pavement areas are required and a typical section has been provided.		
Full depth shoulder reconstruction is needed for staging operations.		
Existing shoulder can be used to carry traffic for staging operations.		
Distressed areas of existing pavement will require joint repair or bituminous patch.		
Sawing and sealing of joints is required.		
Rutting in the existing pavement will require special milling treatments to achieve new cross slope or typical section.		
Conflicting pavement markings and/or plowable pavement reflectors have to be removed and replaced.		

Access		
Provisions were made for workers, equipment and material deliveries to safely enter/exit work zones.		
Provisions were made for emergency vehicle travel through the detour/road closure/lane closure area.		
Provisions were made for bus routes and bus stops within the detour/road closure/lane closure area.		
Access for local business/residents is provided.		
Freeway closure information is clearly shown in plans.		
Required lanes and closure periods for freeways and local streets, are clearly listed in the plans or special provisions.		
Restrictions on access to site or other sensitive environmental issues were evaluated.		
Areas are available for: stockpiling processed material, form lay down and fabrication yards, equipment parking, temporary field offices, personnel parking, and purchased material storage.		
Temporary sidewalks are required.		
Temporary Barriers / Guide Rail		
Where temporary barrier is required, all staged moves are accounted for.		
The transition lengths for temporary barrier curb or guide rail meet or exceed the minimum design standards.		
Temporary barriers are flared to 30 feet outside roadway edge where ever space permits to reduce the use of sand barrel cushions.		
Approved end treatments have been provided for the ends of the barrier curb, guide rail or bridge parapets.		
A warrant evaluation was conducted regarding the use of the quick change movable barrier system as a cost effective method to safely expedite or improve productivity in the construction work zone and shorten the construction duration.		
Input for the justification of use of a quick change movable barrier system was obtained from Traffic Engineering and Regional Construction.		
A quick change movable barrier system will be used on the project.		
Staging requires guide rail to be extended, removed or upgraded along with appropriate approved end treatments and attachments.		
Staging requires existing guide rail to be reset along with appropriate approved end treatments and attachments.		
Temporary Traffic Signals		
Temporary traffic signals are provided for the proposed stage construction and the design has been certified by a New Jersey licensed professional engineer.		
The Traffic Control Plans for the temporary traffic signal(s), including signal phasing design, signs, pavement markings and timing sequence(s) are complete and presented correctly.		
The traffic signal timing has the minimum change, clearance and pedestrian intervals based on the location and approach speed.		

Existing traffic signals are equipped with an optically controlled emergency vehicle detection system.		
Traffic signal timing provides for pre-emption and clearance cycles when adjacent to RR crossings.		
Utilities / Drainage		
All utility conflicts for the stage construction have been resolved.		
Underground work (new storm drains, pipelines, gas, electric, etc.) is sequenced to coincide with or enhance construction phasing.		
Utility relocations that affect the staging of construction are clearly identified within the appropriate sequence of work.		
Underground utilities are located to meet traffic control constraints for lanes, etc. (i.e. check limits on applying a back slope in trenches when calculating lateral clearances. Also check if sheeting or a trench box will be required. Standard segment lengths of pipe should also be considered.)		
Temporary drainage through the project is provided for specific construction phases.		
Consideration was given to obstructions that may pose a hazard to the motoring public during the various stages of construction, i.e. manholes, inlets, sign foundations and footings. (The Designer should not specify full depth precast units for various stage construction with elevation changes.)		
Review the construction staging to determine any seasonal constraints due to weather (i.e. snow removal).		
Consideration was given to the particular stage of construction that will be in place during the winter months, i.e. elevation of manholes and inlets. (This is not only to provide drainage but a smooth pavement and not to interfere with snow plow operations.)		
Detour/diversionary road drains properly to avoid ponding on the pavement.		
Conduit for lighting, ITS and/or signals can be installed during construction sequencing for alignment shown.		
Excavated embankment material is suitable for conduit trench backfilling.		
Power for temporary lighting, signals and utilities is provided.		
Existing inlets and drainage structures need to be cleaned out prior to construction staging.		
Existing inlets and/or manholes need to be reconstructed or have castings replaced prior to construction staging.		
Drainage problems with adjacent properties have been evaluated for the construction staging shown on the Traffic Control Plans.		
Structures		
Work area needs were considered during easement procurement (i.e. space is needed adjacent to a major structure for a form lay down site).		
Sufficient room is provided between new foundations and existing roadways for the excavation, a working area, and a barrier.		
Access to structure locations can be provided which will permit a free flow for transit mixers or trucking and the access is compatible with traffic patterns and safe to merge.		

Pedestrian traffic at structures was addressed and protection provided where required.		
Design of bridges which require falsework construction over traffic conditions allows a 16 feet minimum clearance to the bottom of the falsework.		
Falsework requires illumination for nighttime traffic.		
Traffic flow for phased construction of elevated or depressed structures was considered (i.e. elevation differences that may require the use of sheet piling or some other technique to maintain traffic lanes were evaluated).		
In high volume areas, construction of temporary over/under passes for hauling equipment were considered to avoid traffic conflicts.		
Adequate protection has been provided for the roadway or water course under the structure.		
Traffic stoppage and time limits for stoppage for setting steel over roadway have been indicated.		
Signing		
Signing diagram is clear and understandable.		
Traffic Control signing meets MUTCD standards and the traffic needs in each phase.		
Traffic Control signing is shown for all detours.		
Variable message signs and/or highway advisory radio are needed.		
Special signs are needed for businesses and safety of pedestrians.		
Existing highway signing needs refurbishing or replacement prior to construction staging.		

Section 15 - Traffic Calming

15.1 Introduction

15.1.1 General

Traffic calming may be considered for Department administered or financed projects in accordance with the guidelines and requirements contained in this chapter on roadways:

- with a proposed speed limit of 35 mph or below,
- for Main Streets all highways and streets whose adjacent land uses require accommodation of pedestrians and bicyclists, serious consideration of street aesthetics and a degree of traffic calming
- FHWA must approve of Traffic Calming Devices on all National Highway System (NHS) routes

15.1.2 Objective

The Department's Statement of Design Philosophy for *Proactive Roadway Design* and Complete Streets Policy holds that "in conceiving, scoping and designing projects, the NJDOT will consider the needs of all road users of all ages and abilities. This includes pedestrians, bicyclists, residents, and businesses, as well as drivers." To accomplish this goal, specific design features known as traffic calming may be used. Traffic calming has been in the USA and other countries, shown to reduce motor vehicle speeds and increase vehicular, bicycle and pedestrian safety.

15.1.3 Definition

Traffic calming is the combination of mainly physical measures that alter driver behavior and improve conditions for non-motorized street users. Traffic calming involves changes in street alignment, installation of barriers, and other physical measures to reduce traffic speeds and cut-through volumes in the interest of street safety, livability, and other public purposes.

15.1.4 References

- ITE. *Traffic Calming State of the Practice*.
- ITE. *Guidelines for the Design and Application of Speed Humps*.
- Delaware DOT. *Traffic Calming Design Manual*.
- New York City DOT. *Mini-Roundabout Policy*.
- Seattle Streets Dept. *Traffic Circle Design Guidelines*.
- New York City DOT. *Neckdown Policy*.

15.1.5 Principles

To be considered traffic calming, projects should have an impact on at least one of following:

Vehicle Speed

Vehicle speed is a significant determinant of severity of crashes, should be logical with respect to context, and is a critical factor in safety where there are conflicting traffic modes. Lower vehicle speeds open a range of design options that enable a

street to look less like an expressway and more like a neighborhood street.

Pedestrian and Bicycle Exposure Risk

By making the distance to cross the street shorter, the time spent crossing the street is reduced and the exposure risk is subsequently reduced.

Driver Predictability

If other street users can better predict how and where a particular vehicle will be driven, the street will be safer.

In addition, traffic calming features should be functioning all the time - 24 hours a day, seven days a week.

15.2 General Traffic Calming Design Controls

15.2.1 Design Speed

Generally, the design speed of roadways with traffic calming devices shall be equal to the posted speed limit or statutory speed of the roadway. Traffic calming devices assist in maintaining this design speed (and adherence to the speed limit) by physically limiting the speed at which the design vehicle may traverse the device. The goal is to moderate vehicle speeds along the roadway, and to improve the safety and functionality for all road users.

- Mid-block traffic calming devices (speed table, chicane, median island, and choker) should have a speed profile equal to the design speed of the roadway.
- Traffic calming devices employed at intersections and junctions (mini-roundabout, raised intersection, raised crosswalk) should have a speed profile equal to the posted speed, as these devices essentially replace traffic control devices.
- Traffic calming devices located at the end of speed zone transition areas where the speed changes from **higher to lower** (gateway) should have a speed profile equal to the lower posted speed.
- Traffic calming devices located at the end of speed zone transition areas where the speed changes from **lower to higher** (gateway) should have a speed profile equal to the higher posted speed.

As stated in the MUTCD, advanced warning signs for certain speed differentials shall be posted.

Traffic calming devices that affect turning speeds at intersections (reduced turning radii, forced turn island, diagonal diverter, median barrier, curb extension, realigned intersection) should have a speed profile of 10 mph. This is consistent with AASHTO policies, which state that vehicles turning at intersections designed for minimum-radius turns operate at low speed (less than 10 mph). Refer to *AASHTO Geometric Design of Highways and Streets* 2004 Chapter 2 for the "Minimum Turning Path's of Design Vehicles".

The appropriate turning radii are depicted in Section 6.4, Vehicular Turning Movements.

15.2.2 Clear Zone and Streetscape

For urban arterials, collectors, and local streets where curbs are utilized, space for clear zones is generally restricted. A minimum horizontal clearance distance of 1.5 feet should be provided beyond the face of the curb to all obstructions, with wider offsets provided where practical. The horizontal clearance will generally permit

curbside parking and will not have a negative impact on traffic flow. However, a minimum clear zone distance commensurate with prevailing traffic volumes and vehicle speeds should be provided where practical.

The repetition of vertical elements such as street trees and light fixtures may serve to moderate speeds. First, the roadway corridor is narrowed visually making it feel more intimate and confining. Second, the constant movement of vertical elements in the peripheral vision of the motorist can heighten the motorists' awareness of the surrounding environment.

15.2.3 Signs and Markings

General Guidance

The general rule for signing and marking traffic calming devices is to install markings at the device and install advance warning signage according to the MUTCD. When there is no advance signage, signage should be installed at the device. For specific guidance, see the MUTCD or the NJDOT Standard Sign Manual.

Additional warning signs are not required under the following conditions:

1. Where one device with a similar or lower speed profile follows another by 500 feet or less. For example if speed humps are placed in a series and each is separated by 300 feet, then intermediary advance warning signs are not required. Instead, a rider indicating how far the series extends should be included with the advance warning sign before the first device in the series. Individual signage is not required for each hump.
2. Where one device with a higher speed profile follows another, but the distance is less than that listed in the MUTCD.
3. Where cross traffic enters the traffic calmed street within a series of devices.

Minimizing the Number of Signs

Traffic calming is by its very nature self-enforcing, self-explaining, and self-apparent. To this end, the use of signs shall be kept to a minimum. This is consistent with MUTCD policy which states: warning signs should be used conservatively because these signs, if used to excess, tend to lose their effectiveness. Fewer signs equal better aesthetics and a more context-sensitive approach to roadway design. Good aesthetics and sensitivity to context are imperative to the success of traffic calming schemes.

15.3 Traffic Calming Design Standards

15.3.1 Volume Control Devices

Intersection Median Island

An intersection median island is a small raised median placed in the center of an intersection which physically restricts left turns and through traffic from a cross street or driveway See Figure 15-A. The effect is the same as a normal median that continues through an intersection. An intersection median island can also be designed to calm traffic on the through street.

Median islands follow the same general guidelines for medians found in Section 5.9.1. An important distinction is that traffic calming medians should be raised and dimensions are given for the raised section, exclusive of edge lines and inside shoulders.

Colored and/or textured pavement and landscaping should be considered at islands.

Median islands double as pedestrian refuge islands and shall be designed accordingly. Where there are marked crosswalks, pedestrian ramps or slips shall be provided as per ADA requirements.

If there is a specific cycling facility, it should be incorporated into the design.

EMS access should be considered in such a way as to allow careful access by EMS vehicles if appropriate.

Forced Turn Island

A forced turn island is a traffic island, typically triangular in shape, placed at the mouth of an intersection which channels traffic to the right and restricts left and through movements. The effect is similar to an intersection median island.

Forced turn islands follow the same general guidelines for channelization islands found in Section 6.5.2.

Colored and/or textured pavement and landscaping may be considered at the island.

Forced turn islands double as pedestrian refuge islands and shall be designed accordingly. Where there are marked crosswalks, pedestrian ramps or slips shall be provided as per ADA requirements.

If there is a specific cycling facility, it should be incorporated in the design of the forced turn island.

The forced turn island and overall intersection should be designed to accommodate EMS vehicles.

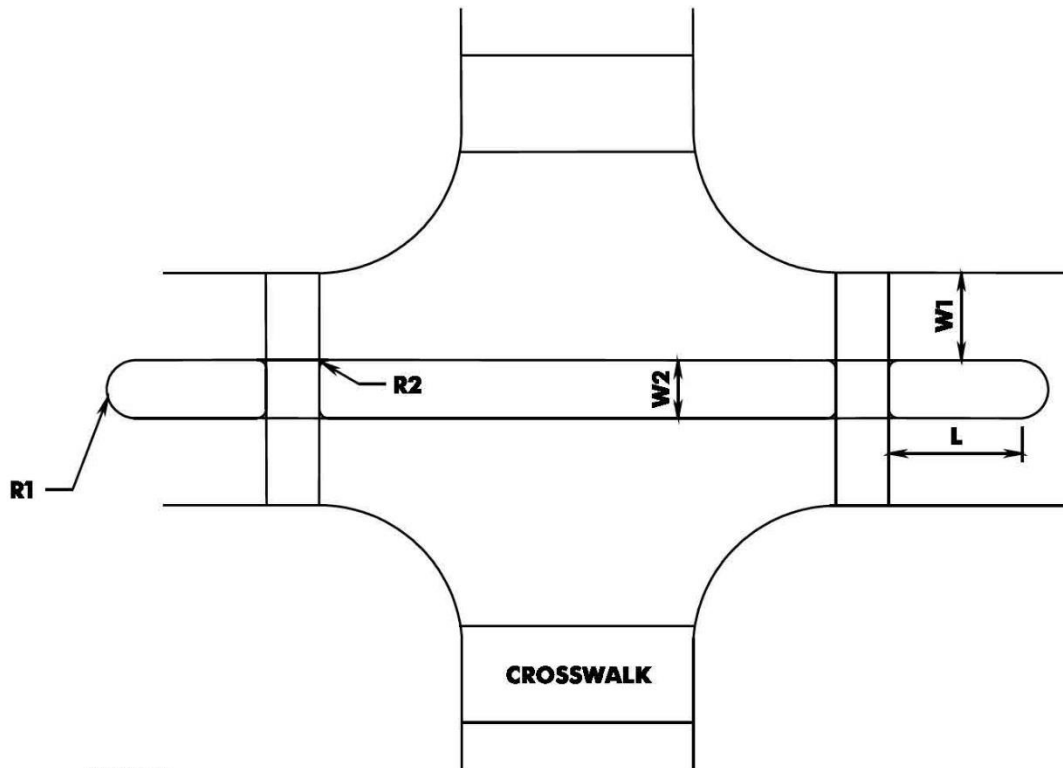
Other volume control devices that are used are the following:

- Full Closure (closing of a street to through traffic at an intersection or midblock)
- Half Closure (closing of a street to through traffic in one direction at an intersection or midblock)
- Diagonal Diverter (barrier placed diagonally across an intersection that forces traffic to turn in one direction and prevents other movements)

The above volume control devices are not expected to be used to control through highways or roads under the Department's jurisdiction. They may be found to be appropriate for use on cross streets or side streets under the jurisdiction of other agencies and as part of a Traffic Calming project. For these types of devices, reference should be made to publications by others for guidance.

Recommendations for signing and pavement markings are provided in the MUTCD.

**FIGURE 15-A:
VOLUME CONTROL DEVICE INTERSECTION MEDIAN
ISLAND**



NOTES:

1. The island should extend past the crosswalk at least 15 feet (L) to discourage drivers circumnavigating the island, and may be lengthened to coordinate with pavement, streetscape, landscape or other urban design treatments. Where there is no crosswalk, L should be measured from the corner radius point of tangent. Island could be altered to provide cut through to accommodate bikes.
2. The lane width (W1) should be sized according to the design vehicle with provision for passing a stalled vehicle.
3. The median width (W2) is desirably 8 feet with a minimum of 6 feet. It is appropriate to restrict parking, narrow travel lanes and/or alter curb lines to achieve this width.
4. The end radius (R1) is typically equal to one-half W2, but may be altered to coordinate with a pavement, streetscape, landscape or other urban design treatment.
5. The radius (R2) is desirably 4 feet, but may be altered to coordinate with a pavement, streetscape, landscape or other urban design treatment.
6. For the design of public sidewalk curb ramps and placement of the detectable warning surface, see Section 5, Major Cross Section Elements, and the Standard Roadway Construction Details.

REV. DATE: JUNE 30, 2015

15.3.2 Speed Control Devices – Vertical Speed Table

A speed table is a raised area placed across the roadway designed to physically limit the speed at which a vehicle can traverse it. They moderate speed by lifting the entire wheelbase of a vehicle up from the plane of the roadway. Speed tables are placed mid-block. See Figure 15-B.

Speed tables may be constructed of asphalt, poured-in-place concrete, pre-cast concrete, brick pavers or other materials that meet the Department's criteria for roadway surfaces.

Speed tables may be constructed with sinusoidal ramps, which provide a smoother ride than flat ramps. These follow the general speed table dimensions.

Speed tables may occur as single devices or in a series. If more than 3 devices are used in a series, consideration should be given to other approaches to control vehicle speeds. The exact number will depend on the roadway context.

Speed tables may be installed on roadways with grades of up to 12 percent. On grades between eight and 12 percent the dimensions of the speed table should be altered to ensure proper performance.

A raised crosswalk is a speed table placed at a preferred crossing location. Raised crosswalks may be installed at an intersection or mid-block.

The primary difference between a speed table and a raised crosswalk is the height and manner in which it meets the curb: with or without a side taper. All other design criteria for speed tables apply. See Figures 15-C and 15-D.

The design of a raised crosswalk without a taper entails continuing the top platform onto the sidewalk and redesigning the curb drainage. Typically, an inlet is placed upstream of the raised crosswalk. The height (H) is desirably the height of the adjoining sidewalk, up to 6 inches. Longer ramps (L3) are required to maintain the proper slope as per Figure 15-C. The raised crosswalk may be lower to coordinate with a series of speed tables, or if a higher speed profile is desired. In this case a modified pedestrian ramp is used.

Detectable warning provisions (a tactile surface) shall be made to warn the visually impaired that they are entering the street, see Detectable Warnings text in Section 5.7. Vertical elements (bollards, trees, planters, street furniture) may be included in the design so that drivers do not treat a raised crosswalk as a driveway.

It is desirable to combine either type of raised crosswalk with curb extensions. All raised crosswalks should be marked.

Raised crosswalks may be stop or yield controlled if warrants are met. Advance markings are not necessary if the raised crosswalk is stop or yield controlled.

Raised Intersection

A raised intersection is a speed table placed in the center of an intersection. The device may exist solely within the curbs, or be combined with raised crosswalks to cover the entire intersection. A raised intersection may be placed at a T or multi-leg intersection. At these intersections, the number of ramps will coincide with the number of intersection legs and each shall be perpendicular to that leg. See Figures 15-E and 15-F.

The primary difference between a speed table and a raised intersection is the height and manner in which it meets the curb. All other design criteria for speed tables apply.

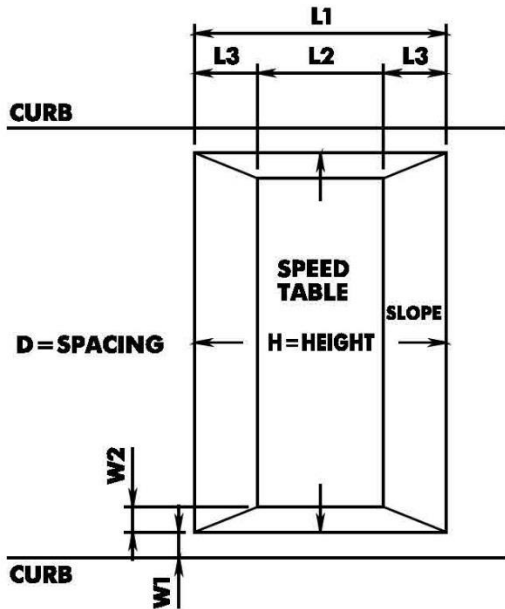
The design of a raised intersection with raised crosswalks entails continuing the top platform onto the sidewalk and redesigning the curb drainage. Typically, an inlet is placed upstream of the intersection. The height (H) is desirably the height of the adjoining sidewalk, up to a maximum of 6 inches. Longer ramps (L3) are required to maintain the proper slope, as per Figure 15-I. The raised crosswalk may be lower to coordinate with a series of speed tables, or if a higher speed profile is desired. In this case, a modified pedestrian ramp is used.

Detectable warning provisions (a tactile surface) shall be made to warn the visually impaired that they are entering the streets. Vertical elements (bollards, trees, planters, street furniture) may be included in the design so that drivers do not treat a raised intersection as a driveway.

It is desirable to combine either type of raised intersection with curb extensions.

Raised intersections may be stop or yield controlled and should include crosswalk markings.

**FIGURE 15-B:
SPEED CONTROL DEVICES - VERTICAL SPEED TABLE**



NOTES:

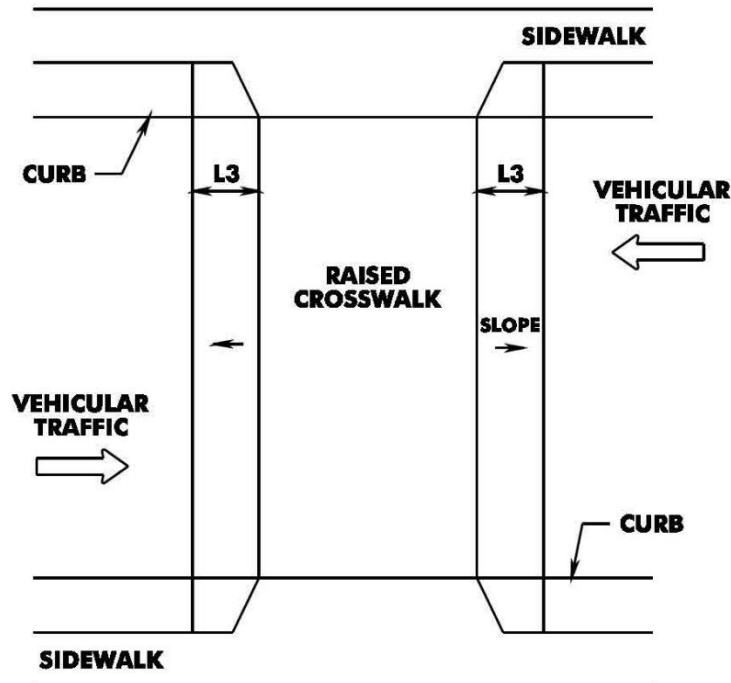
1. Curb to edge width (W1) is desirably 2 feet. Where parking is allowed full-time, this may be widened to 6 feet. Since drivers will seek to avoid traversing a speed table if at all possible, these exceptions should be kept to a minimum.
2. Where there is a marked on-street bike lane, the edge should align with the lane marking (typically 5 feet from the curb).
3. The ratio to determine the side taper width (W2) is 8:1. For a 3-inch table it is 24 inches.
4. On bus or truck routes, the overall length (L1) should be extended to accommodate the wheelbase of the design vehicle. For example, a school bus has a wheelbase of 22 feet, so the speed table would have a top length (L2) of 22 feet. The ramp lengths (L3) remain the same, but the overall length (L1) increases accordingly, up to a maximum of 50 feet.
5. The spacing (D) is given as a range for it is largely dependent on the location of driveways, curves in the roadway, roadway grade, catch basins, utility openings, and roadside features. Above all, speed tables should be located according to context. For example, if a park, school or playground abuts the roadways, then a speed table should be located at or before (in the direction of travel) the entrance to the park, school or playground. Similarly, the nighttime visibility of a speed table can be maximized by locating the speed table directly under a street light, or just after one (in the direction of travel).
6. The top of the speed table should be graded parallel to the roadway.
7. Overall length (L1) may be lengthened to coordinate with pavement, streetscape, landscape or other urban design treatment to a maximum of 50 feet.

Speed Table Dimensions

Speed Profile mph	H Height inches	L1 Overall Length feet	L2 Top Length feet	L3 Ramp Length feet	D Spacing feet
25	3	20	10	5	375-425
30	3	22	10	6	450-500
35	3	26	10	8	525-575

REV. DATE: JUNE 30, 2015

FIGURE 15-C: SPEED CONTROL DEVICES – VERTICAL RAISED CROSSWALK

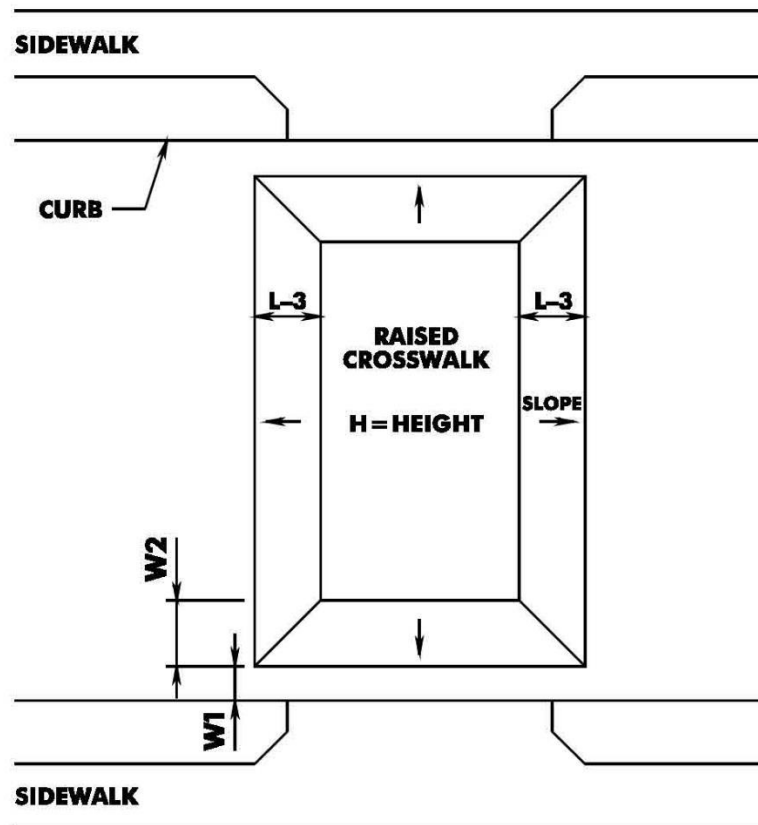


NOTES:

1. Grade top of ramp parallel to roadway.
2. Height (H) shall be 3" high.
3. For design criteria see Figure 15-B.
4. For the design of public sidewalk curb ramps and placement of the detectable warning surface, see Section 5, Major Cross Section Elements, and the Standard Roadway Construction Details.

REV. DATE: JUNE 30, 2015

**FIGURE 15-D:
SPEED CONTROL DEVICES – VERTICAL RAISED
CROSSWALK WITH TAPER DIAGRAM**

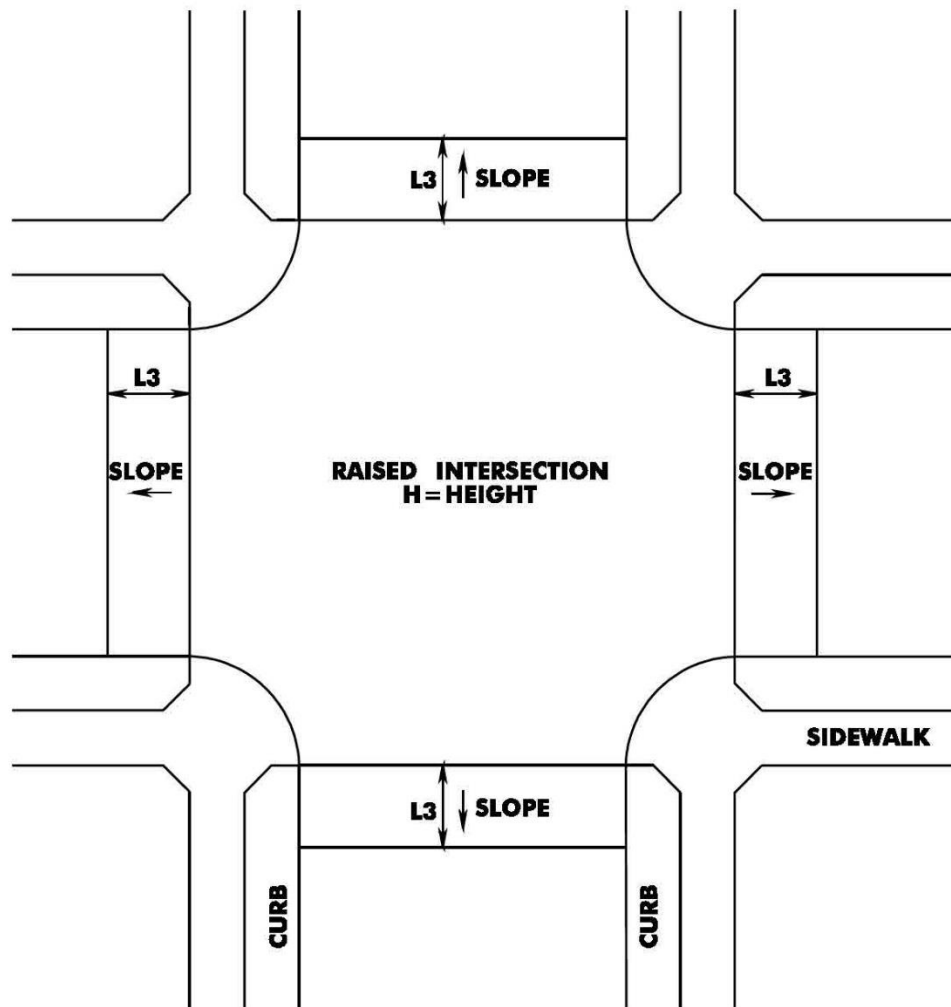


NOTES:

1. Height (H) shall be 3 inches high.
2. The curb edge width (W1) is desirably 2 feet. Where parking is allowed full-time this may be widened to 6 feet to avoid utilities. Since drivers will seek to avoid traversing a table if at all possible, these exceptions should be kept to a minimum. Where there is a marked on-street bike lane the edge should align with the lane marking (typically 5 feet from the curb).
3. The ratio to determine the side taper width (W2) is 12:1 maximum. For a 3-inch raised crosswalk, it is 36 inches minimum width.
4. Grade top of crosswalk parallel to roadway.
5. For design criteria such as ramp width (L3), see Figure 15-B.
6. For the design of public sidewalk curb ramps and placement of the detectable warning surface, see Section 5, Major Cross Section Elements, and the Standard Roadway Construction Details.

REV. DATE: JUNE 30, 2016

**FIGURE 15-E:
SPEED CONTROL DEVICES – VERTICAL RAISED
INTERSECTION**

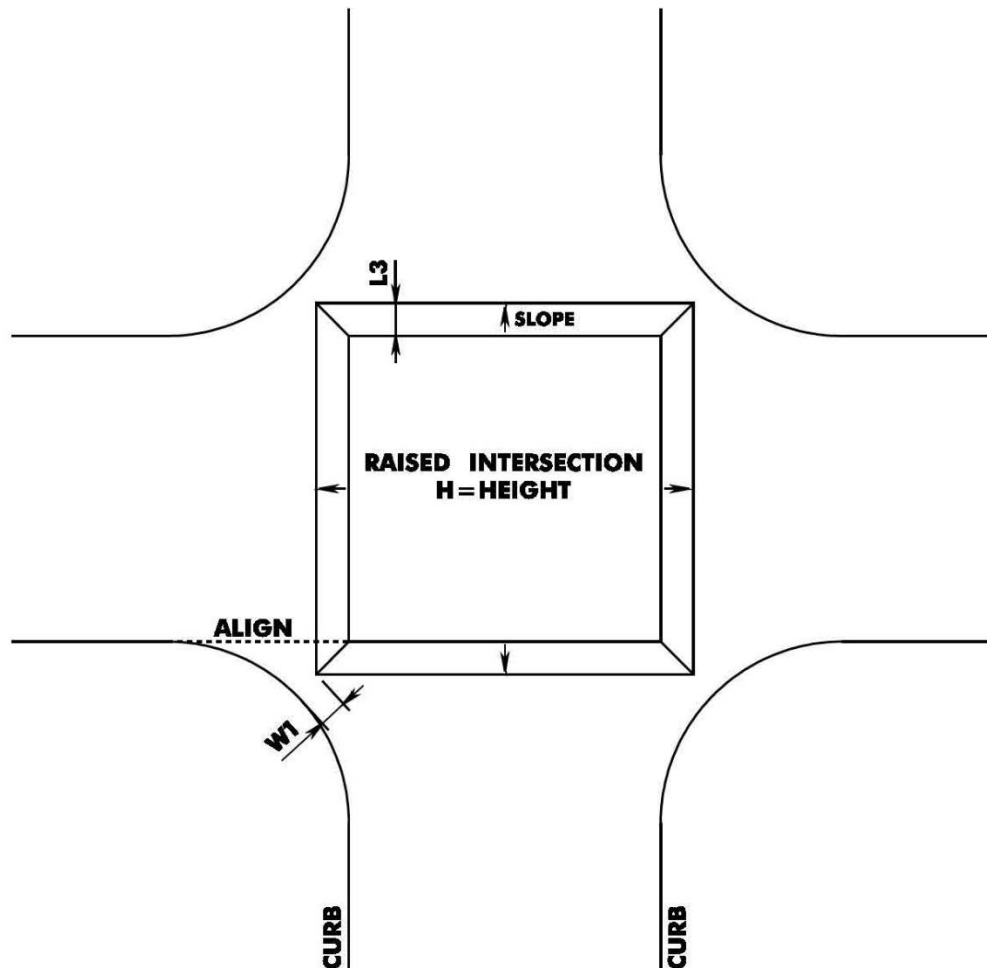


NOTES:

1. Grade top of raised intersection parallel to main roadway.
2. Use Figure 15-B notes for dimensions.
3. For the design of public sidewalk curb ramps and placement of the detectable warning surface, see Section 5, Major Cross Section Elements, and the Standard Roadway Construction Details.

REV. DATE: JUNE 30, 2015

**FIGURE 15-F:
SPEED CONTROL DEVICES – VERTICAL RAISED
INTERSECTION CENTER ONLY**



NOTES:

1. Height (H) shall be 3 inches.
2. The primary design control is the curb to corner width ($W1$). This is desirably 2 feet and establishes the size of the raised intersection. If possible, the top of the table should align with the gutter line
3. For design criteria such as ramp width ($L3$), see Figure 15-B.
4. Grade top of raised intersection parallel to main roadway for appropriate drainage.
5. For the design of public sidewalk curb ramps and placement of the detectable warning surface, see Section 5, Major Cross Section Elements, and the Standard Roadway Construction Details.

REV. DATE: JUNE 30, 2015

15.3.3 Speed Control Devices - Horizontal

Roundabout

A roundabout is a circular, raised traffic island placed within the intersection of two or more streets. It operates on the “yield-on-entry” principle. Drivers circumnavigate the island in a counter-clockwise direction. Roundabouts limit speeds by horizontally deflecting vehicles as they pass through an intersection. They reduce crashes by separating movements and reducing speeds.

At multi-leg, non-perpendicular, or larger intersections, it may be necessary to modify the corner radii, utilize curb extensions, or splitter islands and install splitter islands to achieve the desired speed profile while accommodating the design vehicle. For geometric guidance, see *Roundabouts: An Information Guide*, FHWA.

Roundabouts should be constructed in the same manner as other raised islands and medians. To accommodate SU trucks and buses, the entire circle may be made mountable or the outside portion of the circle may be designed as a truck apron with a sloping curb. The radius of the apron is defined by the sweep of the design vehicle. The intersection may require re-grading to ensure proper drainage and to prevent ice buildup at the circle.

Colored and/or textured pavement and landscaping should be considered at a roundabout, especially vertical elements (trees, bollards, planters) which draw attention but do not reduce sight lines.

On-street bicycle lanes should end before a roundabout so that cyclists mix with traffic. Bicycle lanes should not be marked within the circulatory roadway. Off-street bicycle facilities should be routed around the intersection entirely or may be terminated before the intersection so that cyclists mix with traffic.

See MUTCD for signs and markings.

Realigned Intersection

A realigned intersection refers to the redesign of an intersection for safety or traffic calming purposes. The most common realignment converts a Y- to a T-intersection.

The goals of a redesigned intersection include:

- Slower vehicle turns
- Better sight lines for traffic
- Reduced crossing distances for pedestrians
- Pedestrian refuge areas between different traffic directions
- More predictable driver behavior
- More predictable operating space for cyclists
- Improved stop or yield compliance, especially at crosswalks

Typically, these goals can be met by squaring off the intersection. See also Section 6.5, Channelization, and appropriate exhibits from *A Policy on Geometric Design of Highways and Streets*, AASHTO.

Reduced Turn Radius at Intersection

It is desirable to include a reduction in turning radii and curb extensions in a realigned intersection.

A reduced turn radius refers to using a smaller turning radius (or radii) at an intersection to slow turning traffic and reduce the crossing distance. A reduced turn radius may be accomplished by tightening the corner radius, installing a curb extension, and/or installing a median or island.

The most successful layouts, such as setting the stop line back from a signalized intersection and out of the sweep path safely accommodate the design vehicle while ensuring that smaller vehicles turn slowly.

Chicane

A chicane is a series of alternating curves or lane shifts (caused by placement of obstacles) located to force the driver to steer back and forth out of the normal travel path. The horizontal displacement moderates vehicle speeds. See Figure 15-G.

The chicane islands should be constructed in the same manner as other raised islands and medians.

Chicanes may be used on one-way, one-lane local roads. On two-way, two-lane roadways a chicane should be combined with a median island so that drivers do not simply steer across the centerline.

If the lane shifts or curves are placed at a distance greater than that listed in Figure 15-G, the device is known as a single lane shift or a half-chicane. These may be used on one-way two-lane roadways with volumes of 15,000 ADT and above. These should be limited to signalized roadways where the vehicle platoons will force most drivers to not cross the lane line.

Chicanes may be created by alternating on-street parking or by alternating left and right-turn lanes. These should be augmented with curb extensions if on-street parking demand is less than 50% during the off-peak period.

Landscaping may be used on low speed roads with on-street parking or where the clear zone is not violated, especially vertical elements (trees, bollards, signs) which draw attention but do not reduce sight lines

Mid-block Median Island

A mid-block median island is a short raised median which narrows the roadway in the middle of a block See Figure 15-H. The traffic calming effect is similar to a chicane; a median island and a choker can work together to create a chicane. Median islands often double as pedestrian refuge islands. Where there are mid-block crosswalks is it desirable to locate the median island at the crosswalk.

Median islands follow the same general guidelines for medians found in Section 5.9. An important distinction is that traffic calming medians are raised and dimensions are given for the raised section, exclusive of edge lines and inside shoulders.

Colored and/or textured pavement and landscaping should be considered at a median island.

When there is a bike lane adjacent to the approach of a mid-block island the bicycle lane shall end at the beginning of the taper and cyclists shall merge with traffic.

Choker

A choker is a set of two curb extensions placed directly opposite each another, which narrow the traveled way. See Figure 15-I. In a choker on a two-way, two lane roadways, vehicles are able to pass each other without conflict, yet the narrower cross section makes the margin of error less for drivers. This tends to make drivers

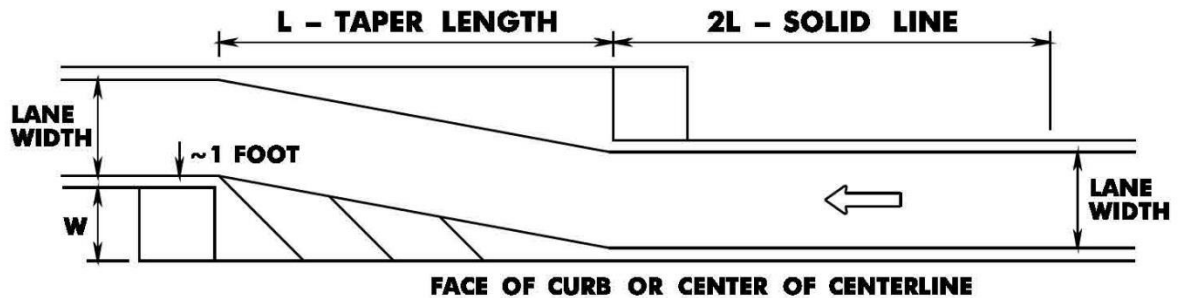
moderate their speed. Where used on a two-way street, consideration should be given to combining a double lane choker with a median island, as this will reduce the possibility of conflicts with opposing traffic.

A choker may be detached from the curb so that drainage is unaffected.

Colored and/or textured pavement and landscaping should be considered at a choker, especially vertical elements (trees, bollards, planters) which draw attention but do not reduce sight lines.

When there is a bike lane adjacent to the approach of a mid-block island, the bike lane shall end at the beginning of the taper prior to the device and cyclist shall merge with traffic.

FIGURE 15-G: SPEED CONTROL DEVICE – HORIZONTAL CHICANE



NOTES:

1. The offset width (W) has a minimum of 6 feet. Where there are no lane markings, the actual operating space between parked cars and/or curb should be used.
2. The taper length (L) is determined from the formula:

$$L = \frac{WS^2}{60}$$

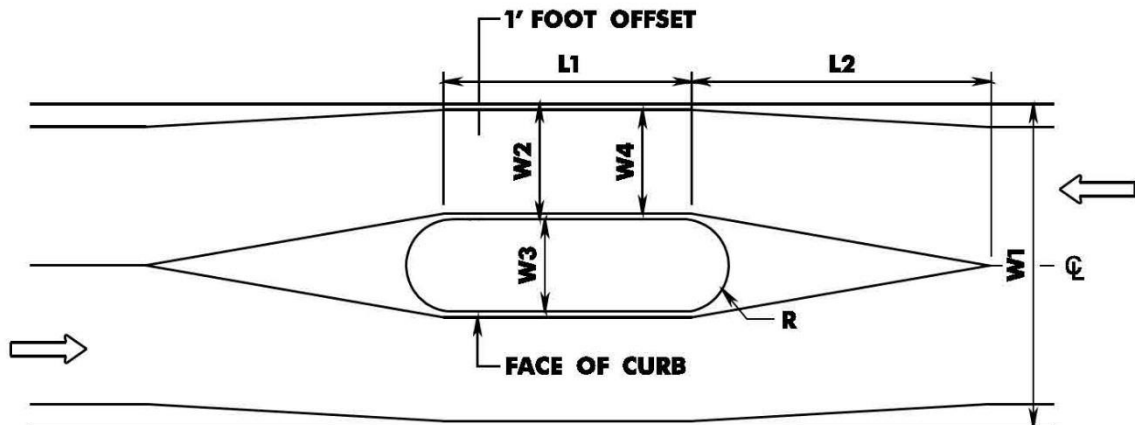
where L is length of taper in feet, W is width the vehicle is forced to shift in feet, and S is desired speed profile in mph.

Taper Lengths

Speed Profile mph	W Offset Width feet						
	6	7	8	9	10	11	12
	L Taper Length, ft						
25	27	33	40	47	53	60	67
30	42	52	63	73	83	94	104
35	60	75	90	105	120	135	150

REV. DATE: JUNE 30, 2016

FIGURE 15-H: SPEED CONTROL DEVICES – HORIZONTAL MIDBLOCK MEDIAN ISLAND

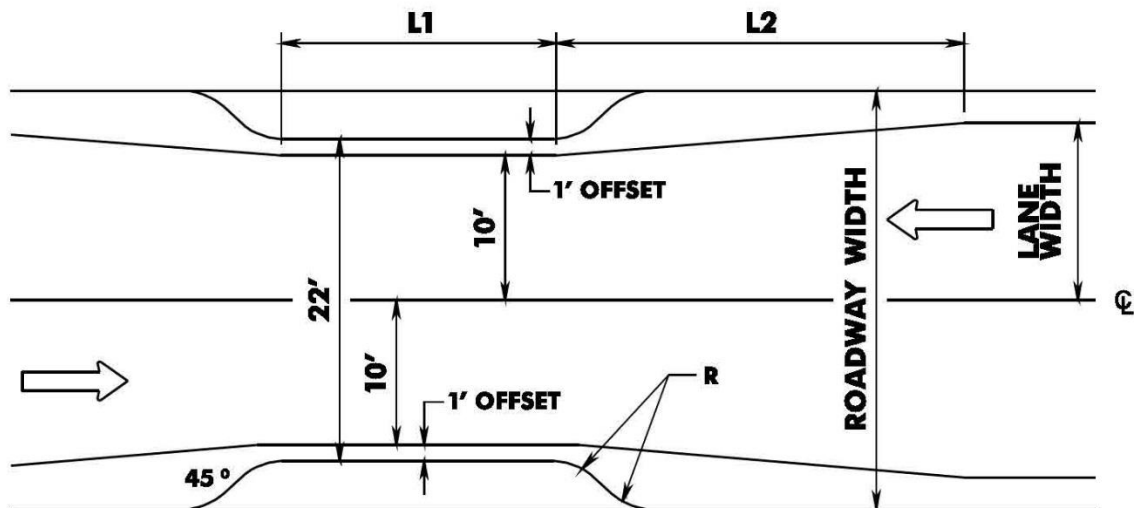


NOTES:

1. The roadway width ($W1$) varies.
2. The opening width ($W2$) is 12 feet.
3. The island width ($W3$) is desirably 8 feet with a minimum of 6 feet.
4. The lane width at the island ($W4$) is 10 feet.
5. The length ($L1$) is desirably 20 feet. It may be shortened or lengthened to coordinate with pavement, streetscape, landscape or other urban design treatments, to a maximum of 50 feet.
6. The taper length ($L2$) is as per Figure 15-G.
7. The island radius (R) is typically equal to one-half $W3$, but may be altered to coordinate with a pavement, streetscape, landscape or other urban design treatment.

REV. DATE: JUNE 30, 2016

FIGURE 15-I: SPEED CONTROL DEVICES – HORIZONTAL CHOKER – DOUBLE LANE



NOTES:

1. The length (L1) is desirably 20 feet. It may be shortened or lengthened to coordinate with pavement, streetscape, landscape or other urban design treatments, to a maximum of 50 feet.
2. The taper length (L2) is as per the Table in figure 15-G.
3. The return angle is 45 degrees.
4. The radius is a desirable 4 feet but may be altered to coordinate with pavement, streetscape, landscape or other urban design treatments.

REV. DATE: JUNE 30, 2015

15.3.4 Other Devices

Curb Extension

A curb extension is a horizontal extension of the sidewalk into the street resulting in a narrower roadway section. See Figures 15-J. This device may be used at either corner or mid-block. Curb extensions may only be used where there is full-time on-street parking upstream of the extension.

Curb extensions are used to:

- Reduce crossing distance for pedestrians.
- Increase space for queuing pedestrians.
- Provide space for pedestrian ramps, and to align them directly with the crosswalk.
- Reduce the space available for dangerous driving maneuvers (passing on the right).
- Slow turning vehicles.
- Self-enforce truck turning prohibitions.

Curb extensions shall be offset from the through traffic by 1.5 feet. This offset is created so cyclists or drivers do not come upon the curb extension unexpectedly. Curb extensions should be designed so that they do not intrude on bicycle operating space. Mid-block curb extensions have not proven to slow traffic, so they are not recommended to be used for this purpose. Where there is an existing or planned mid-block crosswalk, curb extensions should be considered. Specific signs and markings are not required for curb extensions. However, some type of vertical element (tree, bollard, planter, MUTCD object marker OM2-2V) should be installed to alert snow removal vehicle operators.

Narrowed Lane

Narrower lanes have been proven to decrease vehicular speeds. Narrower lanes reduce pedestrian crossing distances and subsequent exposure risk. They allow for a more efficient use of limited right of way widths in urban settings. This provides a benefit when balancing service levels across various modes.

A minimum 10' lane may be used in traffic calming areas. Provisions should also be made for cyclists.

On-street Parking

On-street parking calms traffic by narrowing the roadway and introducing side friction to the traffic flow. For traffic calming designs, the width of a parallel parking lane should be designed so that the minimum lane width of 10 feet is achieved.

Bicycle Lane

On-street bicycle lanes may calm traffic by reducing lane width or removing a lane of traffic. Colored bike lanes may enhance this effect.

Colored and Textured Pavement

Varying the pavement color and/or texture of the roadway accentuates a traffic calming scheme and provides visual and/or sensory cues to drivers and other street users. Typical applications include medians, parking lanes, bus lanes, bicycle lanes, no parking zones, curb ramps, and crosswalks. Textured pavement at crosswalks should be designed with mobility and sight impaired pedestrians in mind. Certain textures may be difficult to traverse with a wheelchair, walker, canes or crutches because of uneven, heavily textured or rough surfaces, or gaps in pavement texture, i.e. spaced unit pavers or certain stamped pavement patterns. Such materials should be reserved

for borders and decorative accents located outside of the pedestrian crosswalk. The preferred method is to keep a smoother texture in the center 4' minimum width and a rougher texture running along the sides of the crosswalk. Colored shoulders, parking or bicycle lanes visually narrow the roadway. Colored or textured pavement does not measurably affect vehicle speed and is recommended to be used in combination with other treatments.

Transverse Rumble Markings

Rumble markings are placed across the lane and cause physical and audible vibrations when driven across. This device consists of three sets of five double layered stripes placed 24 inches on center (See Figure 15-K). This alerts the motorist to an upcoming condition or device, which requires additional attention or a change in driving behavior (toll booths, stop sign, school zone, reduced speed zone, shoulder). Rumble markings are slightly raised elements on the pavement. In advance of the first set of markings, an 8-foot message (SCHOOL, REDUCED SPEED AHEAD, etc.) may be placed on the roadway.

Rumble markings do not measurably affect vehicle speed and should only be used to alert or warn motorists. They may not be suitable in areas sensitive to road noise (residential, hospital, historic). Rumble markings should not extend into the space where the cyclist normally operates, e.g., bike lanes, shoulders, shared parking lanes or wide curb lanes. Where there is no bike lane or shoulder, provide a 4 foot maximum and 3 foot minimum clear distance between rumble stripe and edge of pavement.

Designers are to develop quantities for the transverse rumble markings under the item TRAFFIC MARKINGS, THERMOPLASTIC, Square Foot. Each layer of markings is calculated for the total square footage. A construction detail is to be developed as per Figure 15-K and a note describing payment.

Forced Perspective

A forced perspective is a distinctive striping pattern, intended to make drivers feel that they are traveling faster than they actually are. It is configured as a series of transverse strips, which get sequentially closer together and increase in length as one travels along the street. It is used as advance warning before a traffic calming device or as part of an overall streetscape treatment. Forced perspectives by themselves do not measurably affect vehicle speed and should only be used in advance and in combination with other treatments. The advance warning forced perspective striping pattern is detailed in the MUTCD.

As an overall streetscape treatment, the pattern shown in the MUTCD may be replicated by vertical elements adjacent to or above the roadway. Typical elements include trees, bollards, posts and overhead gantries located in accordance with section 15.2.2.

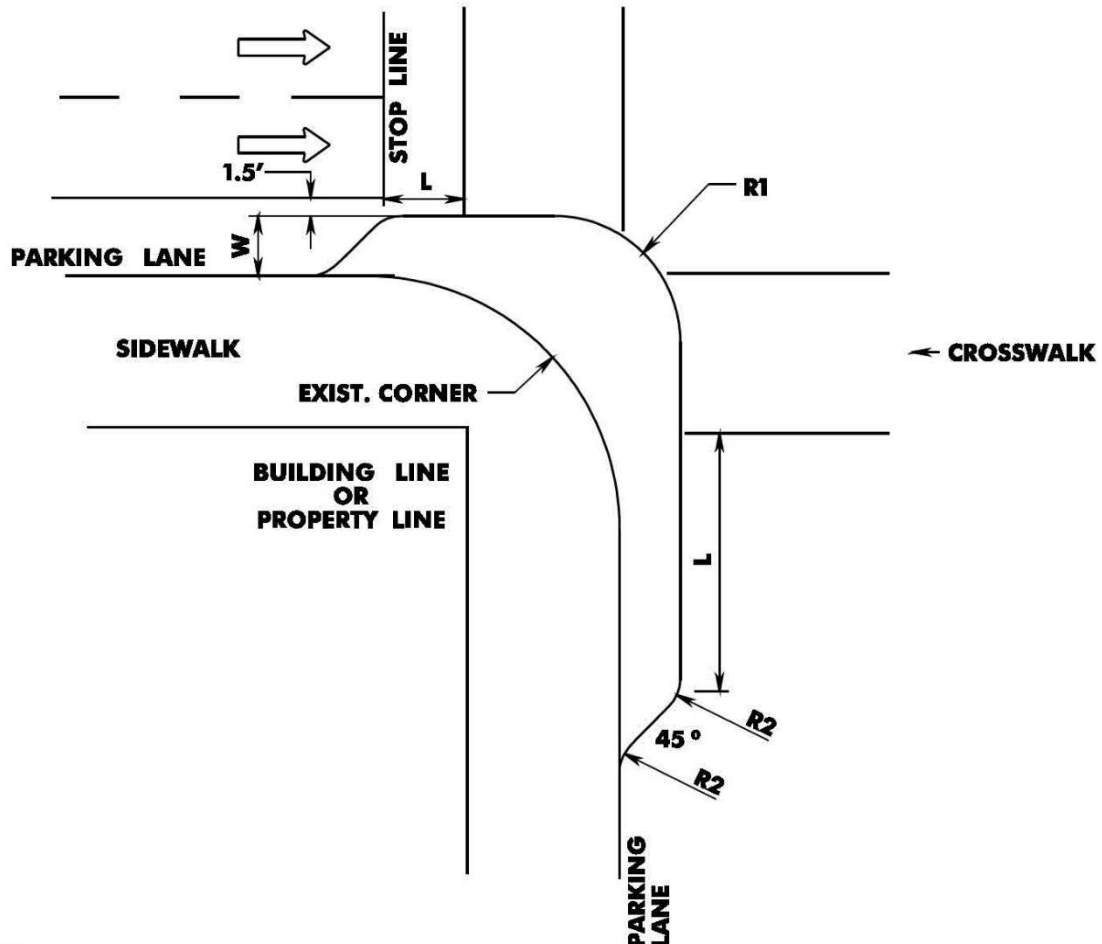
15.3.5 Combination Treatments

Combining traffic calming treatments will often improve their overall effectiveness.

Gateway

A gateway is a combination of devices installed at the beginning of a traffic calming area. Gateways alert drivers to changed conditions and physically force them to alter their driving behavior. They typically consist of curb extensions, chokers, textured pavement, chicanes, roundabouts, speed tables, narrowed lanes, etc. Rumble stripes, a forced perspective, warning signs, etc. may precede them.

**FIGURE 15-J:
OTHER CONTROL DEVICES CORNER CURB EXTENSION**

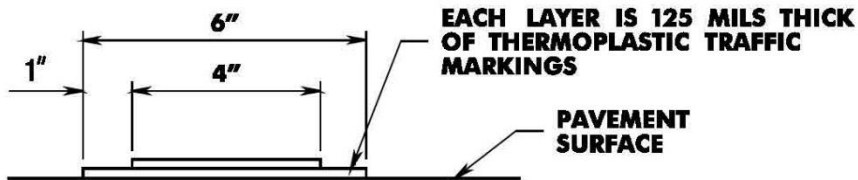
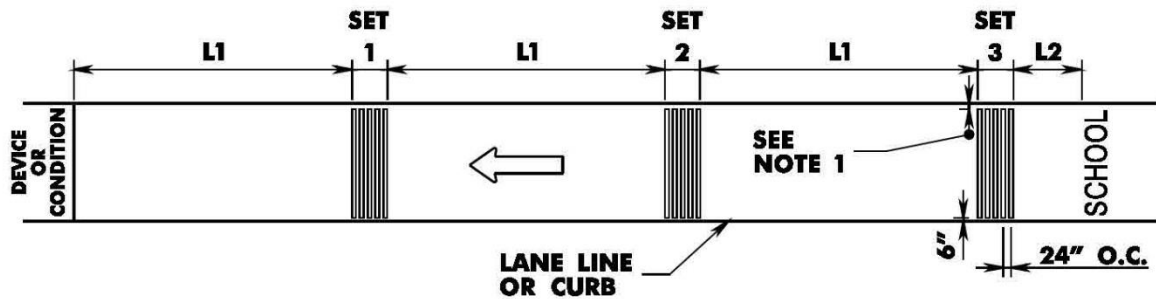


NOTES:

1. The corner radius ($R1$), typically 10–15 feet, is based on the inside turning radius of the design vehicle and desired turning speed.
2. The width (W) is equal to the width of the parking lane minus 1.5 feet. The return angle is 45 degrees.
3. The distance between the crosswalk and the return (L) varies and should be coordinated with the pavement, streetscape, landscape or other urban design treatment. For example where there is a stop line L should be extended to it. Where a fire hydrant is within 40 feet of the crosswalk (or extension of the property/building line), L may be extended so that the hydrant may be relocated onto the curb extension. L may also be lengthened to accommodate street furniture, bus shelters, sidewalk cafes or other roadside uses, to increase stopping sight distance, or to provide a clear corner zone.
4. The radius ($R2$) is desirably 4 feet, but may be altered to coordinate with a pavement, streetscape, landscape or other urban design treatment.
5. For the design of public sidewalk curb ramps and placement of the detectable warning surface, see Section 5, Major Cross Section Elements, and the Standard Roadway Construction Details.

REV. DATE: JUNE 30, 2016

FIGURE 15-K: TRANSVERSE RUMBLE MARKINGS



RUMBLE MARKING DETAIL

NOTES:

1. Where there is no desirable bike lane or shoulder, provide 4 ft. desirable and 3 ft. minimum clear distance between rumble marking and lane line or curb.
2. Installation consists of three sets of five markings.

Rumble Marking Spacing

Posted speed at upcoming condition or element, mpg	L1 Distance between sets, ft	L2 Distance between first set and message in roadway, ft
25	75	20
30	85	25
35	95	30

REV. DATE: JUNE 30, 2016